

## Application Note

### Experion LX: Outstanding Control for Mid-Sized Power Plants



#### Challenge: Establishing a seamlessly integrated control system

A typical mid-sized power plant has three different main areas: boiler, turbines, and balance-of-plant. The tight integration of these three areas is crucial, especially as each has its specific control requirements. For example, a boiler requires very precise PID control, whereas in the balance-of-plant area, control depends on the correct handling of discrete inputs/outputs.

The first requirement is therefore to establish a seamlessly integrated control solution for the power plant that encompasses all areas – from high-performance PID control for boiler applications to the discrete input/outputs of the balance of plant area – while improving the overall productivity of the power plant.

Another aspect of importance in a power plant is how well the control system integrates with the electrical area, which can consist of a whole range of equipment such as smart relays, smart drives and smart switchgear. This is vital, to allow an operator to control the entire power plant from a single system in the control room.

#### Solution: Experion LX

A member of Honeywell's long-established and highly successful Experion family of Distributed Control Systems, Experion LX is specifically designed to meet the needs of mid-sized power plants. It integrates state-of-the-art technology from the award-winning Experion Process Knowledge System (PKS) with innovatively designed Series 8 I/O modules and cabinets, a validated and wide range of commercially available items (COTS) options, easy engineering and maintenance capabilities, and integrator-friendly programs and tools. It leverages Honeywell's proven track record in DCS applications, and is a mature system with well-defined Function Blocks and highly proven technology.

Experion LX is the perfect platform for process, asset and business management with small to medium complexity, and enables customers to increase their profitability, productivity, and accessibility to local support without sacrificing quality and reliability in an increasingly competitive environment.

For mid-sized power plants, Experion LX provides a unique control solution that is superior to solutions based on Programmable Logic Controllers (PLCs).

And, as already mentioned, a mid-size power plant needs very high-performance PID control for boiler control, turbine monitoring, and other applications. Experion LX is a unique solution for the mid-power segment as it provides high-performance continuous process control integrated with the electrical control area.

Furthermore, Experion LX is designed to be implemented and supported by Honeywell's Channel Partners. These are trained and locally available engineers who can provide the engineering and configuration help necessary to get the system up and running efficiently and within the shortest possible time.

#### (i) Architecture

The Experion LX platform comprises many different integrated hardware and software solutions depending upon the needs of the application. Figure 1 is a representation of many of the possible nodes that can be used in the Experion LX architecture. Note that the architecture is highly scalable and not all nodes are necessary or required.

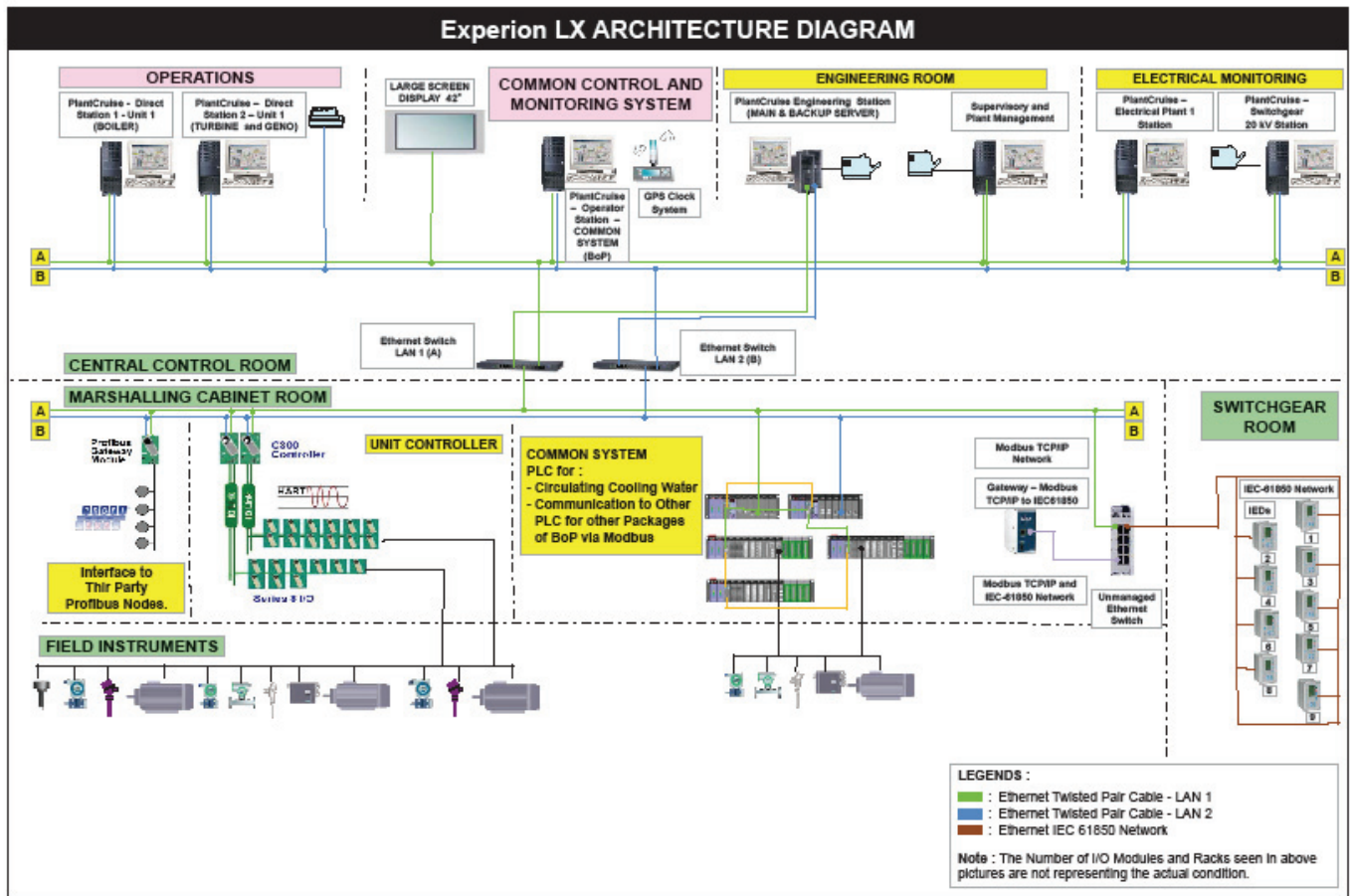

Figure 1. Typical Experion LX architecture.

In Figure 1, the Unit controllers deal with boiler control and turbine monitoring. This area needs tight, high-performance, closed loop PID control to ensure optimization and improvement of boiler performance. Experion LX delivers this high performance on account of its Function Blocks which provide much higher levels of control than any PLC-based technology.

In the middle of the architecture diagram is the common system (balance-of-plant) for circulation of cooling water and communication to third-party systems. As mentioned earlier, this area requires excellent control of discrete input/output modules. Experion LX provides a highly cost-effective control solution for this area by integrating Honeywell's MasterLogic PLCs. MasterLogic PLC is a pocket-sized industrial logic controller powered by a high-speed processor. Its high performance enables fast discrete and sequencing control, while saving space and operations costs with its small and compact modular size.

Further on the right – the small boxes connected with the red lines – is the electrical area, called here the switchgear room, which consists of smart relays connected together via the IEC 61850 network communication protocol. This area is tightly integrated with the backbone of Experion LX which is the Fault Tolerant Ethernet (FTE, the green and blue lines). The FTE connects tightly to the electrical area so that the whole is one unified control system handling all applications of the power plant.

Experion LX therefore connects different platforms together in a unified and seamlessly integrated way to form a single homogenous control system specifically for mid-power applications.

### (ii) C300 Controller

At the heart of Experion LX is Honeywell's C300 Controller which provides powerful and robust control. The C300 is a node in Honeywell's field-proven deterministic Control Execution Environment (CEE) core software. The CEE software provides a superior control execution and scheduling environment. Control strategies for each controller node are configured and loaded through an easy and intuitive engineering tool called Control Builder. Features of Control Builder include:

- Flexible configuration environment.
- Control loop configuration, to modify the control loop online.
- Graphical modular configuration, real-time monitoring and debugging environment.
- S88 modular batch automation.
- Hierarchical classification management.
- Builds common global database for all system nodes (controller and HMI).

In addition to a standard and robust library of pre-built function blocks and algorithms, the C300 controller also supports Custom Algorithm Blocks (CABs). These are similar in purpose and structure to the standard function blocks that are distributed with Control Builder. However, CABs have user-defined algorithms and data structures, allowing tailored strategies to be developed to specific requirements.



Figure 2. C300 controller.

The C300 controller supports the space-saving Series 8 I/O and industry standard protocols for smart device integration such as Profibus, Modbus, and HART.

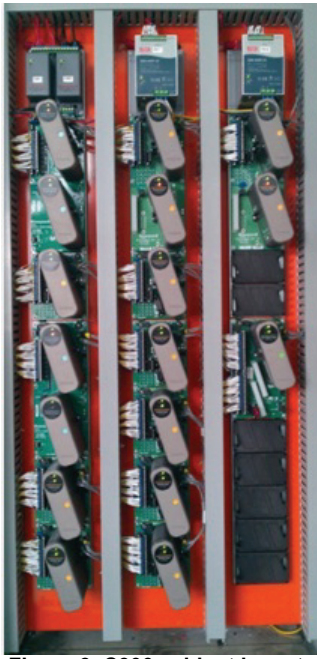

Figure 3. C300 cabinet layout.

The design of the C300 cabinet (Figure 3) is both vertical and compact. It incorporates slanted modules for heat dissipation, reducing “hot spots”. Its field wiring has been designed to be optimal, with top/bottom wiring connections, and connectors that are easy to connect and remove. Its compact design saves space and eases maintenance.

**(iii) Direct Station**

The Experion LX Direct Station is the human-machine interface (HMI) that can be used for different functions around the power plant including operations, monitoring, maintenance and engineering.

The Direct Station is connected to the C300 controller, from which it directly accesses process data, alarms, and messages. There is no loss of view of critical data and alarms if the server fails and therefore an operator can still control and monitor the process. This is particularly helpful in an environment where continuity of view is paramount and where it is important to minimize the impact of a server being unavailable.

The Direct Station is connected to the Experion LX Engineering Station for communication to SCADA and Distributed System Architecture (DSA) point sources, system history, the system event journal, and the system configuration file server. The Direct Station supports the implementation of a “logical console”. This allows operators to fully respond to all alarms/events within their scope of responsibility regardless of operator actions on other stations. In doing so, it provides a single work space for an operator for event handling, alarm acknowledgement, alarm silencing, display manipulation and other functions.



Figure 4. The Experion LX Direct Station.

**(iv) Series 8 I/O**

The Experion LX Series 8 I/O consists of the following modules:

- Digital Input Sequence of Events.
- Digital Input.
- Digital Output.
- Analog Input with HART.
- Analog Input.
- Analog Output with HART.

- Analog Output.
- Low Level Analog Inputs – RTD & TC.

All Series 8 components feature an innovative design that supports enhanced heat management. This unique look provides a significant reduction in overall size for the equivalent function.

Series 8 I/O displays a number of unique features such as:

- I/O Module and field terminations combined in the same area. The Input Output Module (IOM) is plugged onto the Input Output Termination Assembly (IOTA) to eliminate the need for a separate chassis to hold the electronics assemblies.
- Two level “detachable” terminals land the field wiring in the enclosure, providing easier plant installation and maintenance.
- Power to field devices is supplied through the IOTA, with no need for extra power supplies and the associated craft wired marshalling.
- Redundancy is accomplished directly on the IOTA without any external cabling or redundancy control devices, by simply adding a second IOM to an IOTA.
- Conformal coating of electronic circuitry to act as protection against moisture, dust, chemicals, and temperature extremes is provided as a standard. Coated IOM and IOTA are recommended when electronics must withstand harsh environments and added protection is necessary.
- DI SOE provides 1ms resolution time stamping of events at the I/O level and integrated with the Alarm subsystem and reporting functions.

The Series 8 is innovatively styled, with features that facilitate the effective use of control hardware in a system environment:

- Vertical mounting allows for more effective wiring since most field wiring applications require entry from the top or bottom of the system cabinet.
- An “information circle” allows for a quick visual cue to bring the maintenance technician’s attention to important status information.
- “Tilted” design allows for effective heat management within the cabinet enclosure. Since Series 8 allows for a significant increase in cabinet density, an effective heat management system is critical for high system availability.
- Input and output circuits are protected from shorts to alleviate the need for in-line fusing, reducing installation and maintenance costs.

In virtually all configurations, the C300 controller and Series 8 I/O provide useful, maintainable process equipment connections in a smaller footprint than competitive systems. Installing Series 8 I/O Modules contributes to overall total installed cost savings.

### (v) Fault Tolerant Ethernet (FTE)

FTE is the control network for the Experion family. FTE provides multiple communication paths between nodes, enabling an FTE network to tolerate all single faults and many multiple faults. FTE is dedicated to the control mission – providing not only fault tolerance but also the performance, determinism, and security required for industrial control applications.

FTE unites Honeywell’s expertise in designing robust control networks with commercial Ethernet technology in a patented advanced networking solution. While FTE is not a general purpose Information Technology (IT) network due to its control mission, it leverages commercial Ethernet technology to lower the costs of the FTE network Infrastructure, connections to IT networks, connections to third-party Ethernet devices, and on-going maintenance and support.

An FTE network is implemented through FTE nodes and appropriately configured switches. Normal Ethernet nodes can also connect to an FTE network, and benefit from its highly available communications environment.

Experion LX also communicates with other Honeywell products such as Safety Manager on the FTE same network FTE. This is particularly advantageous in a power plant’s boiler area where safety is a high priority.

**(vi) Function Blocks**

Experion LX has a comprehensive Function Block library that is dedicated to power plants. Six are shown below:

**HT Motor Function Block.**

The HT Motor Function Block is customized to meet the HT motor drive control requirements of power plants. It is designed to accept inputs and interlocks pertaining to conventional HT motor drives and their switchgear, and is capable of controlling drives through output governed by predetermined logic.

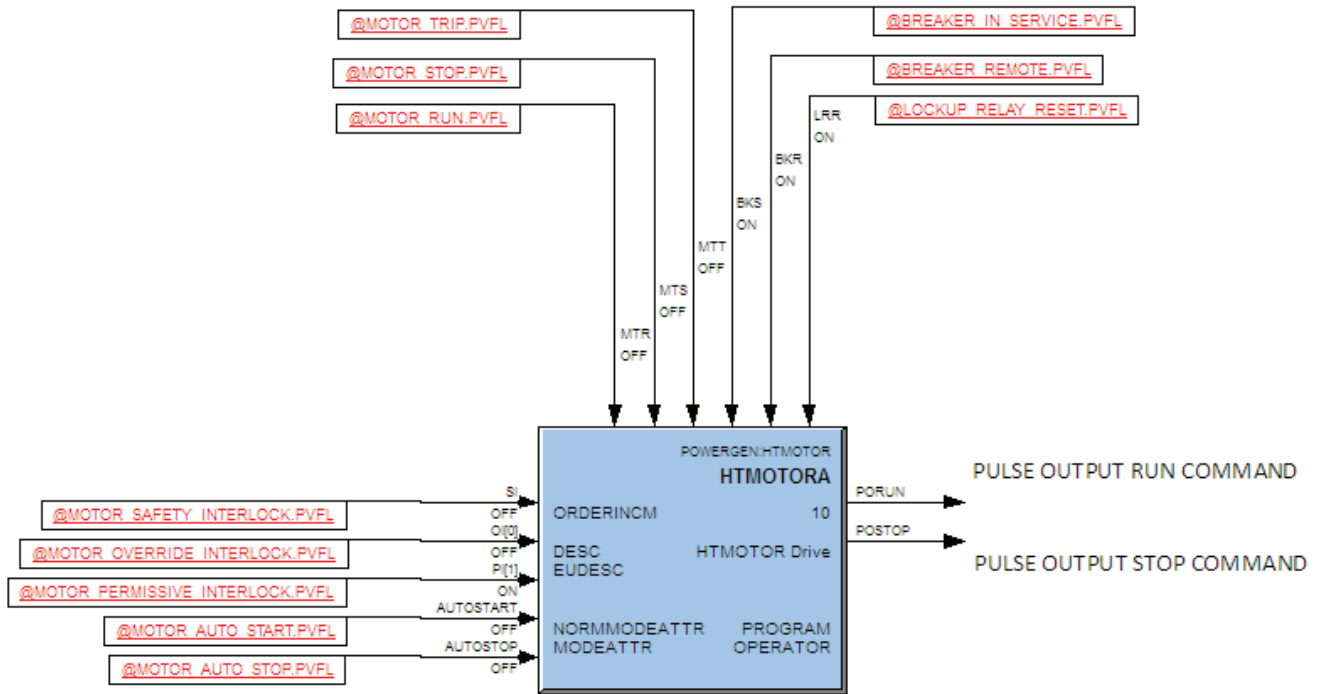

**Figure 5. HT Motor Function Block**

### Drum Level Computation Function Block

Drum level is computed based on measured Differential Pressure (DP). DP to level computation techniques are employed in level measurements in boiler drum, de-aerators and HP heaters where the process fluid is at high temperature and pressure.

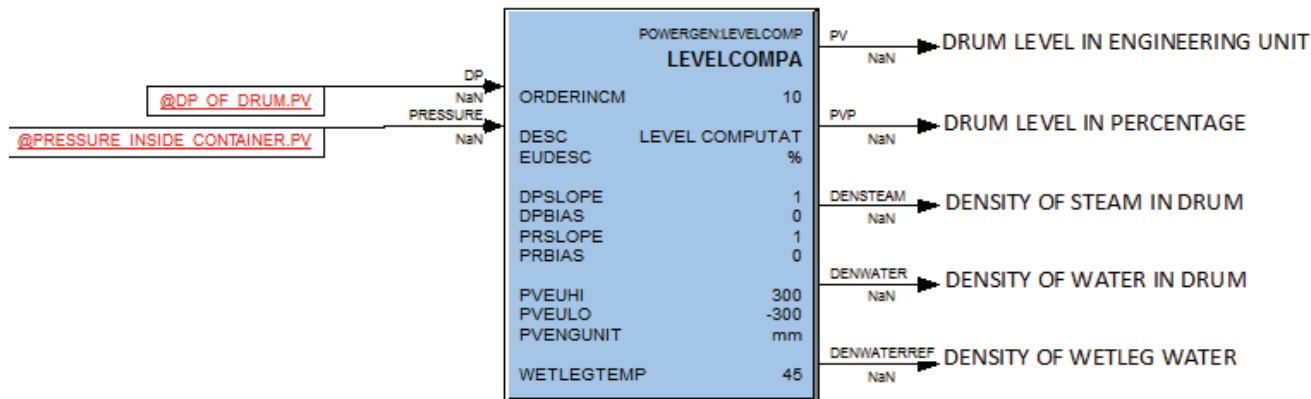

Figure 6. Drum Level Computation Function Block.

### LT Motor Function Block

The LT Motor Function Block is customized to meet the LT motor drive control requirements of power plants. It is designed to accept inputs and interlocks pertaining to conventional LT motor drive MCC, and is capable of controlling drives through output governed by predetermined logic.

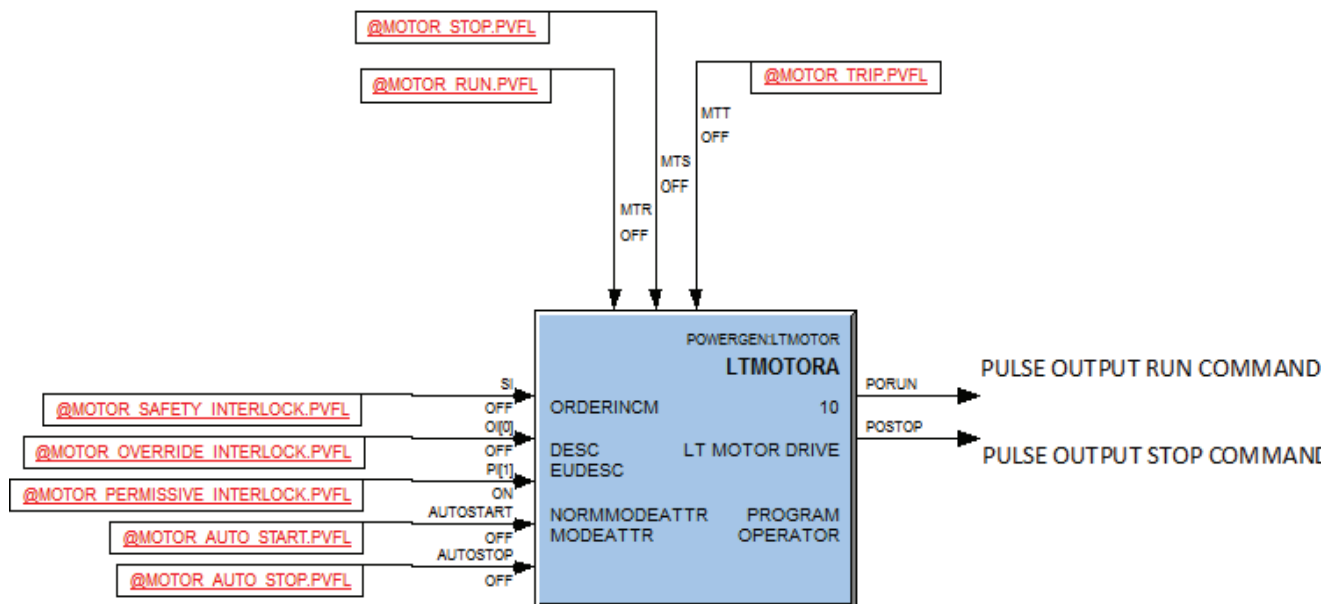

Figure 7. LT Motor Function Block.

### Main IBV Logic Function Block

Main IBV Logic is required for valves which have a small bypass valve connected across the main valve port. The main valve opens only when the bypass valve opens fully, and there is sufficient time to equalize the pressure across the main valve.

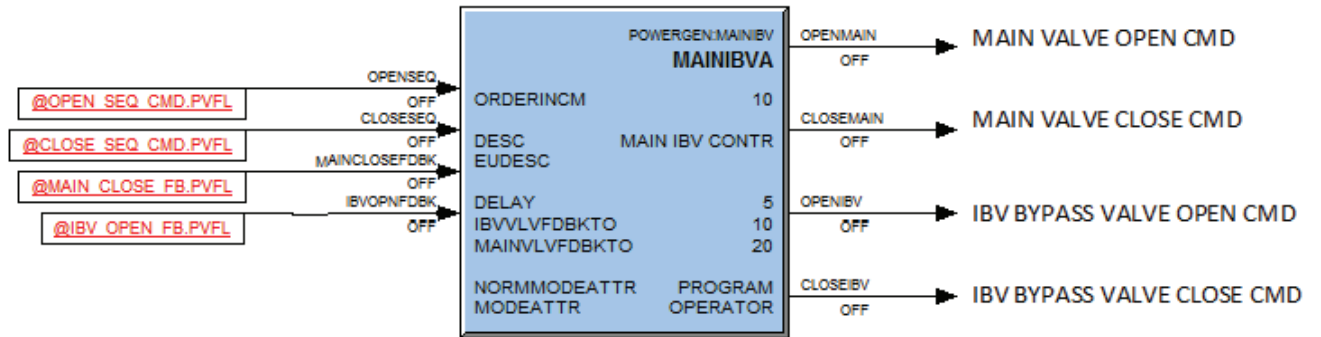

Figure 8. Main IBV Logic Function Block.

### Solenoid Valve Control Function Block

Solenoid Valve Control is designed to accept inputs and interlocks pertaining to a conventional solenoid, and is capable of controlling a valve through output governed by predetermined logic.

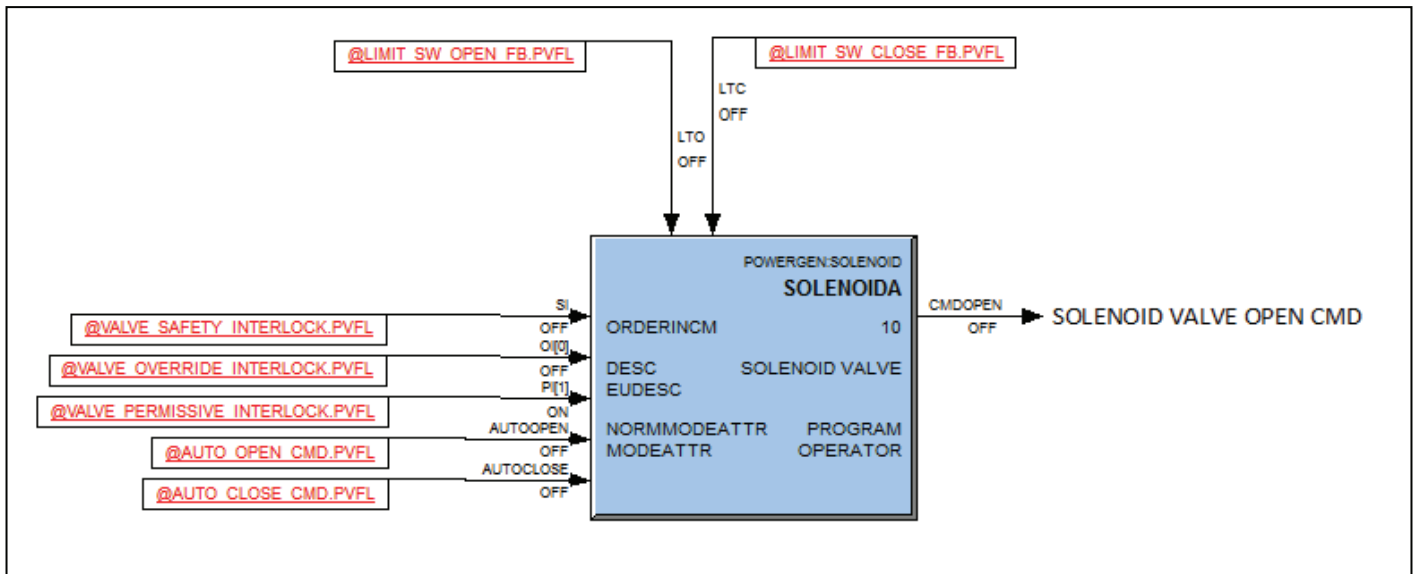

Figure 9. Solenoid Valve Control Function Block.



### Valve/Damper Control Function Block

The Valve/Damper Control Function Block is customized to meet the motor operated valve and damper control requirements of power plants. It is designed to accept inputs and interlocks pertaining to conventional valves, and is capable of controlling valves through output governed by predetermined logic.

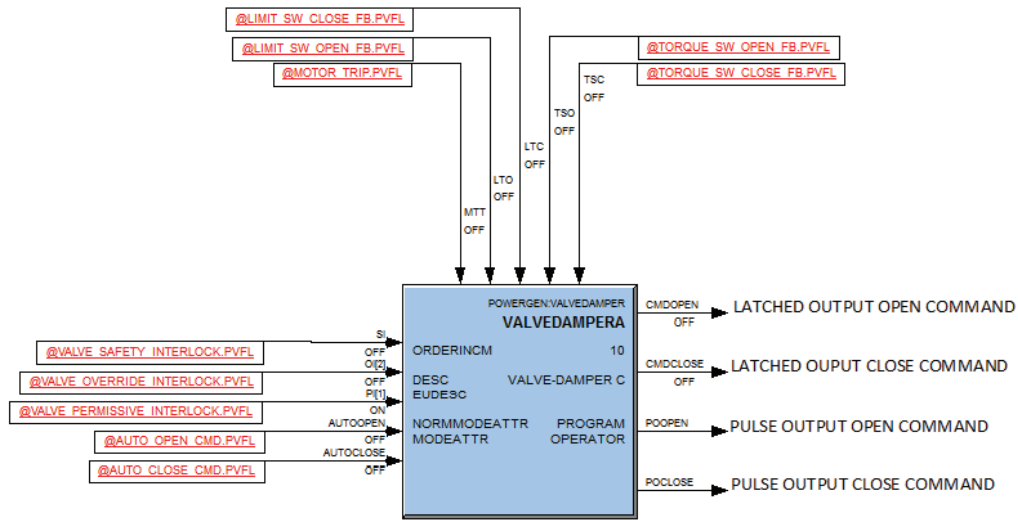

Figure 10. Valve/Damper Control Function Block.

### (vii) Distributed System Architecture

Experion LX incorporates Honeywell’s unique Distributed Server Architecture (DSA). DSA integrates processes across multiple units, control rooms or geographically distributed locations for optimum flexibility and system maintenance. It enables multiple Experion LX systems to share data, alarms, messages, and history without the need for duplicate configuration on any system.

DSA can be configured using existing displays, provides a global name space for access to all point information, and supports redundant networks and servers.

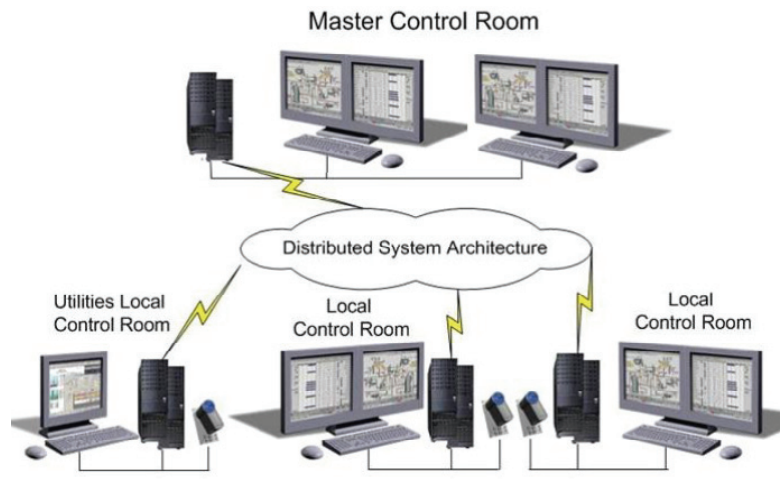

Figure 11. Experion LX Distributed System Architecture.

### (viii) Experion eServer

Experion eServer is Honeywell's unique web server solution based on Distributed System Architecture (DSA) that enables access to Experion LX anytime and anywhere. As a unique web server solution, Experion eServer provides scalable, low-cost and highly secure web access for any concurrent number of users.

Experion eServer is an integrated, view-only web server solution that offers secure access to real-time and historical process data from the control room. With just an Internet browser, Experion eServer users can view the same custom process graphics as those used by operations, irrespective of their location on the business network. Experion eServer provides the flexibility to accommodate a variety of user needs and requirements within an organization as well as maintains the integrity of the process control system. Customers benefit from fast retrieval of data with robust security.

## The Honeywell Advantage

The challenge of mid-sized power plants is that they have a limited budget compared to larger power plants. They need high performance and tight integration for Boiler / Turbine, BOP and Electrical area. Experion LX provides value through providing the right technology and integration of the C300 controller, Safety Manager, MasterLogic PLC and interfaces to the electrical area providing the most optimal control for plant efficiency, safety, reliability and cost.

Experion LX delivers the lowest lifecycle cost solution for mid-power applications because of its ability to integrate different technologies while at the same time delivering the high performance required for the boiler control and turbine monitoring areas.

### For More Information

To learn more about Honeywell's Experion LX visit our website [www.honeywellprocess.com](http://www.honeywellprocess.com) or contact your Honeywell distributor.

### Honeywell Process Solutions

Honeywell  
1250 West Sam Houston Parkway South  
Houston, TX 77042

Honeywell House, Arlington Business Park  
Bracknell, Berkshire, England RG12 1EB UK

Shanghai City Centre, 100 Junyi Road  
Shanghai, China 20051

[www.honeywellprocess.com](http://www.honeywellprocess.com)