

Type 11

Connection Head ATEX Exia

Connection Heads

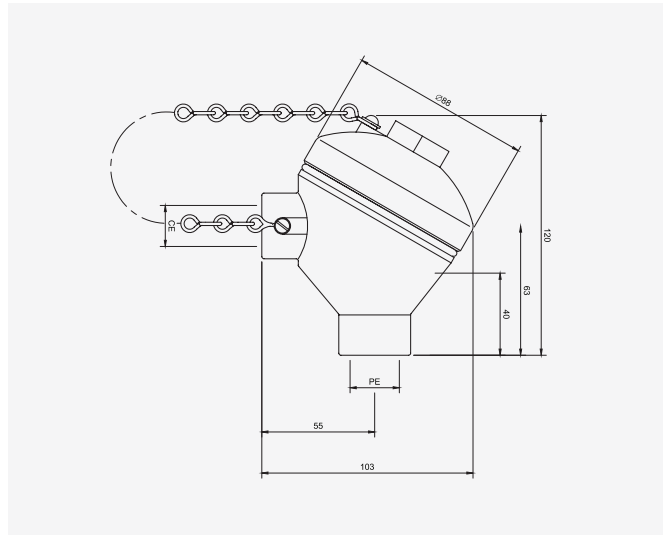

The Type 11 connection head is manufactured from high quality aluminium with a tough silver epoxy painted finish and includes a safety chain. This aluminium housing can be fitted with most types of ceramic terminal block or DIN standard transmitter and is weatherproof to IP65. If required this connection head can be supplied with ATEX Exia approval for use within intrinsically safe environments when manufactured as part of an assembly by H&B Sensors. Additional options include either a M24 x 1.5 or 1/2" BSPP threaded probe entry.

Material	Aluminium
Cable Entry	M20 x 1.5
Probe Entry	M24 x 1.5 or 1/2" BSPP
IP Rating	IP65
Approvals	ATEX Exia
Termination	Terminal Block / Transmitter
Weight (Kg)	0.4

Approval	Classification	Certificate #
ATEX Exia	II 1 G	BSI 06 ATEX 2501284X