

# Operating Instructions

Radar sensor for continuous level measurement of liquids

## VEGAPULS 64

Two-wire 4 ... 20 mA/HART



Document ID: 51141



**VEGA**

# Contents

<b>1</b>	<b>About this document</b> .....	<b>4</b>
1.1	Function .....	4
1.2	Target group .....	4
1.3	Symbols used.....	4
<b>2</b>	<b>For your safety</b> .....	<b>5</b>
2.1	Authorised personnel .....	5
2.2	Appropriate use.....	5
2.3	Warning about incorrect use.....	5
2.4	General safety instructions .....	5
2.5	EU conformity.....	6
2.6	NAMUR recommendations .....	6
2.7	Radio license for Europe .....	6
2.8	Radio license for USA .....	7
2.9	Radio license for Canada .....	7
2.10	Installation and operation in the USA and Canada .....	9
2.11	Environmental instructions .....	9
<b>3</b>	<b>Product description</b> .....	<b>11</b>
3.1	Configuration .....	11
3.2	Principle of operation.....	12
3.3	Packaging, transport and storage.....	13
3.4	Accessories and replacement parts .....	13
<b>4</b>	<b>Mounting</b> .....	<b>15</b>
4.1	General instructions .....	15
4.2	Mounting versions, plastic horn antenna .....	15
4.3	Mounting preparations, mounting strap .....	18
4.4	Mounting instructions .....	19
4.5	Measurement setup - Flow .....	27
<b>5</b>	<b>Connecting to power supply</b> .....	<b>29</b>
5.1	Preparing the connection .....	29
5.2	Connecting .....	30
5.3	Wiring plan, single chamber housing.....	31
5.4	Wiring plan, double chamber housing .....	32
5.5	Wiring plan - version IP 66/IP 68, 1 bar.....	33
5.6	Switch-on phase.....	33
<b>6</b>	<b>Set up with the display and adjustment module</b> .....	<b>35</b>
6.1	Insert display and adjustment module .....	35
6.2	Adjustment system .....	36
6.3	Measured value indication - Selection of national language .....	37
6.4	Parameter adjustment - Quick setup .....	38
6.5	Parameter adjustment - Extended adjustment.....	38
6.6	Saving the parameterisation data .....	54
<b>7</b>	<b>Setup with PACTware</b> .....	<b>55</b>
7.1	Connect the PC.....	55
7.2	Parameter adjustment with PACTware .....	55
7.3	Saving the parameterisation data .....	57

<b>8</b>	<b>Set up with other systems .....</b>	<b>58</b>
8.1	DD adjustment programs .....	58
8.2	Field Communicator 375, 475 .....	58
<b>9</b>	<b>Diagnosis, asset management and service .....</b>	<b>59</b>
9.1	Maintenance .....	59
9.2	Measured value and event memory .....	59
9.3	Asset Management function.....	60
9.4	Rectify faults.....	63
9.5	Exchanging the electronics module.....	67
9.6	Software update .....	67
9.7	How to proceed if a repair is necessary.....	68
<b>10</b>	<b>Dismount.....</b>	<b>69</b>
10.1	Dismounting steps.....	69
10.2	Disposal .....	69
<b>11</b>	<b>Supplement .....</b>	<b>70</b>
11.1	Technical data .....	70
11.2	Radio astronomy stations.....	83
11.3	Dimensions .....	83
11.4	Industrial property rights.....	96
11.5	Trademark .....	96



### Safety instructions for Ex areas

Take note of the Ex specific safety instructions for Ex applications. These instructions are attached as documents to each instrument with Ex approval and are part of the operating instructions.

Editing status: 2019-03-20

# 1 About this document

## 1.1 Function

This operating instructions provides all the information you need for mounting, connection and setup as well as important instructions for maintenance, fault rectification, the exchange of parts and the safety of the user. Please read this information before putting the instrument into operation and keep this manual accessible in the immediate vicinity of the device.

## 1.2 Target group

This operating instructions manual is directed to trained personnel. The contents of this manual must be made available to the qualified personnel and implemented.

## 1.3 Symbols used



### Document ID

This symbol on the front page of this instruction refers to the Document ID. By entering the Document ID on [www.vega.com](http://www.vega.com) you will reach the document download.



### Information, tip, note

This symbol indicates helpful additional information.



**Caution:** If this warning is ignored, faults or malfunctions can result.  
**Warning:** If this warning is ignored, injury to persons and/or serious damage to the instrument can result.



**Danger:** If this warning is ignored, serious injury to persons and/or destruction of the instrument can result.



### Ex applications

This symbol indicates special instructions for Ex applications.



### List

The dot set in front indicates a list with no implied sequence.



### Action

This arrow indicates a single action.



### Sequence of actions

Numbers set in front indicate successive steps in a procedure.



### Battery disposal

This symbol indicates special information about the disposal of batteries and accumulators.

## 2 For your safety

### 2.1 Authorised personnel

All operations described in this documentation must be carried out only by trained, qualified personnel authorised by the plant operator.

During work on and with the device, the required personal protective equipment must always be worn.

### 2.2 Appropriate use

VEGAPULS 64 is a sensor for continuous level measurement.

You can find detailed information about the area of application in chapter "*Product description*".

Operational reliability is ensured only if the instrument is properly used according to the specifications in the operating instructions manual as well as possible supplementary instructions.

### 2.3 Warning about incorrect use

Inappropriate or incorrect use of this product can give rise to application-specific hazards, e.g. vessel overflow through incorrect mounting or adjustment. Damage to property and persons or environmental contamination can result. Also, the protective characteristics of the instrument can be impaired.

### 2.4 General safety instructions

This is a state-of-the-art instrument complying with all prevailing regulations and directives. The instrument must only be operated in a technically flawless and reliable condition. The operator is responsible for the trouble-free operation of the instrument. When measuring aggressive or corrosive media that can cause a dangerous situation if the instrument malfunctions, the operator has to implement suitable measures to make sure the instrument is functioning properly.

During the entire duration of use, the user is obliged to determine the compliance of the necessary occupational safety measures with the current valid rules and regulations and also take note of new regulations.

The safety instructions in this operating instructions manual, the national installation standards as well as the valid safety regulations and accident prevention rules must be observed by the user.

For safety and warranty reasons, any invasive work on the device beyond that described in the operating instructions manual may be carried out only by personnel authorised by the manufacturer. Arbitrary conversions or modifications are explicitly forbidden. For safety reasons, only the accessory specified by the manufacturer must be used.

To avoid any danger, the safety approval markings and safety tips on the device must also be observed and their meaning read in this operating instructions manual.

Depending on the instrument version, the emitting frequencies are in the C, K or W band range. The low emission power is far below the internationally approved limit values. When used correctly, the device poses no danger to health.

## 2.5 EU conformity

The device fulfils the legal requirements of the applicable EU directives. By affixing the CE marking, we confirm the conformity of the instrument with these directives.

You can find the EU conformity declaration on our website under [www.vega.com/downloads](http://www.vega.com/downloads).

## 2.6 NAMUR recommendations

NAMUR is the automation technology user association in the process industry in Germany. The published NAMUR recommendations are accepted as the standard in field instrumentation.

The device fulfils the requirements of the following NAMUR recommendations:

- NE 21 – Electromagnetic compatibility of equipment
- NE 43 – Signal level for fault information from measuring transducers
- NE 53 – Compatibility of field devices and display/adjustment components
- NE 107 – Self-monitoring and diagnosis of field devices

For further information see [www.namur.de](http://www.namur.de).

## 2.7 Radio license for Europe

The instrument was tested according to the latest issue of the following harmonized standards:

- EN 302372 - Tank Level Probing Radar
- EN 302729 - Level Probing Radar

It is hence approved for use inside and outside closed vessels in countries of the EU.

Use is also approved in EFTA countries, provided the respective standards have been implemented.

For operation inside of closed vessels, points a to f in annex E of EN 302372 must be fulfilled.

For operation outside of closed vessels, the following conditions must be fulfilled:

- The instrument must be stationary mounted and the antenna directed vertically downward
- The instrument may only be used outside closed vessels in the version with G 1½ or 1½ NPT thread with integrated horn antenna.
- The mounting location must be at least 4 km away from radio astronomy stations, unless special permission was granted by the responsible national approval authority

- When installed within 4 to 40 km of a radio astronomy station, the instrument must not be mounted higher than 15 m above the ground.

You can find a list of the respective radio astronomy stations in chapter "Supplement".

## 2.8 Radio license for USA

This approval is only valid for USA. Hence the following text is only available in the English language:

This device complies with Part 15 of the FCC Rules. Operation is subject to the following two conditions:

- This device may not cause interference, and
- This device must accept any interference, including interference that may cause undesired operation of the device

This device is approved for unrestricted use only inside closed, stationary vessels made of metal, reinforced fiberglass or concrete.

For operation outside of closed vessels, the following conditions must be fulfilled:

- This device shall be installed and maintained to ensure a vertically downward orientation of the transmit antenna's main beam. Furthermore, the use of any mechanism that does not allow the main beam of the transmitter to be mounted vertically downward is prohibited.
- Operation of the instrument is only permitted with thread G1½ or 1½ NPT with integrated horn antenna.
- This device shall be installed only at fixed locations. The LPR device shall not operate while being moved or while inside a moving container.
- Hand-held applications are prohibited.
- Marketing to residential consumers is prohibited.

Changes or modifications not expressly approved by the manufacturer could void the user's authority to operate this equipment.

## 2.9 Radio license for Canada

This approval is only valid for Canada. Hence the following texts are only available in the English/French language:

This device complies with Industry Canada's license-exempt RSS standard(s). Operation is subject to the following conditions:

- This device may not cause interference, and
- This device must accept any interference, including interference that may cause undesired operation of the device

This device has been approved for both closed containers and open-air environments with the following limitations:

- Closed Containers: For installations utilizing a tilt during installation: This device is limited to installation in a completely enclosed container made of metal, reinforced fiberglass or concrete to pre-

vent RF emissions, which can otherwise interfere with aeronautical navigation, the maximum approved tilt angle is 10°.

- Open Air Environment: For operation outside of closed vessels, the following condition must be fulfilled: This device shall be installed and maintained to ensure a vertically downward orientation of the transmit antenna's main beam. Furthermore, the use of any mechanism that does not allow the main beam of the transmitter to be mounted vertically downward is prohibited.
- Operation of the instrument outside of closed vessels is only permitted with G1½ or 1½ NPT with integrated horn antenna.
- The installation of the LPR/TLPR device shall be done by trained installers, in strict compliance with the manufacturer's instructions.
- This device shall be installed only at fixed locations. The LPR device shall not operate while being moved or while inside a moving container.
- Hand-held applications are prohibited.
- Marketing to residential consumers is prohibited.
- The use of this device is on a "no-interference, no-protection" basis. That is, the user shall accept operations of high-powered radar in the same frequency band which may interfere with or damage this device.
- However, devices found to interfere with primary licensing operations will be required to be removed at the user's expense.
- The installer/user of this device shall ensure that it is at least 10 km from the Dominion Astrophysical Radio Observatory (DRAO) near Penticton, British Columbia. The coordinates of the DRAO are latitude 49°19'15" N and longitude 119°37'12"W. For devices not meeting this 10 km separation (e.g., those in the Okanagan Valley, British Columbia,) the installer/user must coordinate with, and obtain the written concurrence of, the Director of the DRAO before the equipment can be installed or operated. The Director of the DRAO may be contacted at 250-497-2300 (tel.) or 250-497-2355 (fax). (Alternatively, the Manager, Regulatory Standards, Industry Canada, may be contacted.)

Le présent appareil est conforme aux CNR d'Industrie Canada applicables aux appareils radio exempts de licence. L'exploitation est autorisée aux conditions suivantes :

- L'appareil ne doit pas produire de brouillage; et
- L'utilisateur de l'appareil doit accepter tout brouillage radioélectrique subi, même si le brouillage est susceptible d'en compromettre le fonctionnement.

Cet appareil est homologué pour une utilisation dans les cuves fermées et les environnements ouverts avec les restrictions suivantes :

- Cuves fermées : Pour les installations impliquant une inclinaison lors de l'installation : cet appareil ne doit être installé que dans une cuve totalement fermée en métal ou en béton, pour empêcher les émissions RF susceptibles d'interférer avec la navigation aéronautique. L'angle d'inclinaison maximum autorisé est de 10°.
- Environnement ouvert : Pour l'utilisation hors des cuves fermées, la condition suivante doit être remplie : L'appareil doit être installé



et entretenu de manière à garantir une orientation verticale vers le bas du faisceau principal de l'antenne émettrice. De plus, l'utilisation de tout mécanisme ne permettant pas l'orientation verticale vers le bas du faisceau principal de l'émetteur est interdite

- Il est uniquement autorisé d'utiliser la version d'appareil avec le filetage G1½ ou 1½ NPT en environnements ouvertes.
- L'installation d'un dispositif LPR ou TLPR doit être effectuée par des installateurs qualifiés, en pleine conformité avec les instructions du fabricant.
- Cet appareil ne doit être installé qu'à des emplacements fixes. L'appareil LPR ne doit pas être utilisé pendant qu'il est en train d'être déplacé ou se trouve dans un conteneur en mouvement.
- Les applications portables sont interdites.
- La vente à des particuliers est interdite
- Ce dispositif ne peut être exploité qu'en régime de non-brouillage et de non-protection, c'est-à-dire que l'utilisateur doit accepter que des radars de haute puissance de la même bande de fréquences puissent brouiller ce dispositif ou même l'endommager.
- D'autre part, les capteurs de niveau qui perturbent une exploitation autorisée par licence de fonctionnement principal doivent être enlevés aux frais de leur utilisateur.
- La personne qui installe/utilise ce capteur de niveau doit s'assurer qu'il se trouve à au moins 10 km de l'Observatoire fédéral de radioastrophysique (OFR) de Penticton en Colombie-Britannique. Les coordonnées de l'OFR sont : latitude N 49° 19' 15", longitude O 119° 37' 12". La personne qui installe/utilise un dispositif ne pouvant respecter cette distance de 10 km (p. ex. dans la vallée de l'Okanagan [Colombie-Britannique]) doit se concerter avec le directeur de l'OFR afin d'obtenir de sa part une autorisation écrite avant que l'équipement ne puisse être installé ou mis en marche. Le directeur de l'OFR peut être contacté au 250-497-2300 (tél.) ou au 250-497-2355 (fax). (Le Directeur des Normes réglementaires d'Industrie Canada peut également être contacté).

## 2.10 Installation and operation in the USA and Canada

This information is only valid for USA and Canada. Hence the following text is only available in the English language.

Installations in the US shall comply with the relevant requirements of the National Electrical Code (ANSI/NFPA 70).

Installations in Canada shall comply with the relevant requirements of the Canadian Electrical Code

A Class 2 power supply unit has to be used for the installation in the USA and Canada.

## 2.11 Environmental instructions

Protection of the environment is one of our most important duties. That is why we have introduced an environment management system with the goal of continuously improving company environmental pro-

tection. The environment management system is certified according to DIN EN ISO 14001.

Please help us fulfil this obligation by observing the environmental instructions in this manual:

- Chapter "*Packaging, transport and storage*"
- Chapter "*Disposal*"

### 3 Product description

#### 3.1 Configuration

##### Type label

The type label contains the most important data for identification and use of the instrument:



Fig. 1: Layout of the type label (example)

- 1 Instrument type
- 2 Product code
- 3 Type approval mark
- 4 Power supply and signal output, electronics
- 5 Protection rating
- 6 Measuring range
- 7 Permissible process pressure
- 8 Material wetted parts
- 9 Serial number of the instrument
- 10 Data matrix code for VEGA Tools app
- 11 Reminder to observe the instrument documentation

##### Serial number - Instrument search

The type label contains the serial number of the instrument. With it you can find the following instrument data on our homepage:

- Product code (HTML)
- Delivery date (HTML)
- Order-specific instrument features (HTML)
- Operating instructions and quick setup guide at the time of shipment (PDF)
- Order-specific sensor data for an electronics exchange (XML)
- Test certificate (PDF) - optional

Move to "[www.vega.com](http://www.vega.com)" and enter in the search field the serial number of your instrument.

Alternatively, you can access the data via your smartphone:

- Download the VEGA Tools app from the "Apple App Store" or the "Google Play Store"
- Scan the Data Matrix code on the type label of the instrument or
- Enter the serial number manually in the app

##### Scope of this operating instructions

This operating instructions manual applies to the following instrument versions:

- Hardware version from 1.0.3

- Software version from 1.3.1

### Scope of delivery

The scope of delivery encompasses:

- Radar sensor
- Disc springs (flange version with encapsulated antenna system)<sup>1)</sup>
- Optional accessory
- Documentation
  - Quick setup guide VEGAPULS 64
  - Instructions for optional instrument features
  - Ex-specific "*Safety instructions*" (with Ex versions)
  - If necessary, further certificates



#### Information:

Optional instrument features are also described in this operating instructions manual. The respective scope of delivery results from the order specification.

## 3.2 Principle of operation

### Application area

VEGAPULS 64 is a radar sensor for continuous level measurement of liquids.

The small process fittings offer particular advantages in small tanks or tight mounting spaces. The very good signal focusing ensures the use in vessels with many installations such as stirrers and heating spirals.

The VEGAPULS 64 is available with different antenna systems:

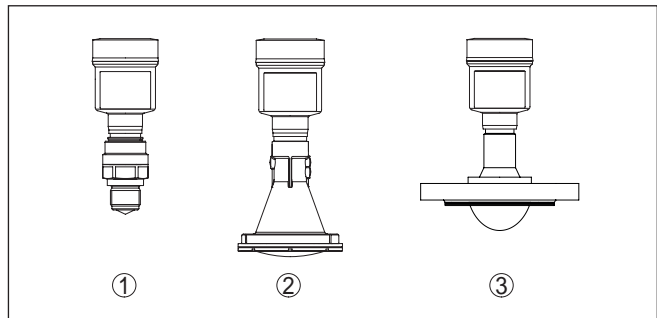

Fig. 2: Antenna systems VEGAPULS 64

- 1 Thread with integrated horn antenna
- 2 Plastic horn antenna
- 3 Flange with encapsulated antenna system

### Functional principle

The instrument emits a continuous radar signal through its antenna. This signal is frequency modulated in the form of a sawtooth wave. The emitted signal is reflected by the medium and received by the antenna as an echo with modified frequency. The frequency change is proportional to the distance and is converted into the filling level.

<sup>1)</sup> Use see chapter "Mounting instructions, sealing to the process"

### 3.3 Packaging, transport and storage

**Packaging**

Your instrument was protected by packaging during transport. Its capacity to handle normal loads during transport is assured by a test based on ISO 4180.

The packaging of standard instruments consists of environment-friendly, recyclable cardboard. For special versions, PE foam or PE foil is also used. Dispose of the packaging material via specialised recycling companies.

**Transport**

Transport must be carried out in due consideration of the notes on the transport packaging. Nonobservance of these instructions can cause damage to the device.

**Transport inspection**

The delivery must be checked for completeness and possible transit damage immediately at receipt. Ascertained transit damage or concealed defects must be appropriately dealt with.

**Storage**

Up to the time of installation, the packages must be left closed and stored according to the orientation and storage markings on the outside.

Unless otherwise indicated, the packages must be stored only under the following conditions:

- Not in the open
- Dry and dust free
- Not exposed to corrosive media
- Protected against solar radiation
- Avoiding mechanical shock and vibration

**Storage and transport temperature**

- Storage and transport temperature see chapter "*Supplement - Technical data - Ambient conditions*"
- Relative humidity 20 ... 85 %

**Lifting and carrying**

With instrument weights of more than 18 kg (39.68 lbs) suitable and approved equipment must be used for lifting and carrying.

### 3.4 Accessories and replacement parts

**PLICSCOM**

The display and adjustment module PLICSCOM is used for measured value indication, adjustment and diagnosis.

The integrated Bluetooth module (optional) enables wireless adjustment via standard adjustment devices.

**VEGACONNECT**

The interface adapter VEGACONNECT enables the connection of communication-capable instruments to the USB interface of a PC.

**VEGADIS 81**

The VEGADIS 81 is an external display and adjustment unit for VEGA plics® sensors.

**VEGADIS adapter**

The VEGADIS adapter is an accessory part for sensors with double chamber housings. It enables the connection of VEGADIS 81 to the sensor housing via an M12 x 1 plug.

<b>VEGADIS 82</b>	VEGADIS 82 is suitable for measured value indication and adjustment of sensors with HART protocol. It is looped into the 4 ... 20 mA/HART signal cable.
<b>PLICSMOBILE T81</b>	The PLICSMOBILE T81 is an external GSM/GPRS/UMTS radio unit for transmission of measured values and for remote parameter adjustment of HART sensors.
<b>PLICSMOBILE 81</b>	PLICSMOBILE 81 is an internal GSM/GPRS/UMTS radio unit for HART sensors for transmitting measured values and for remote parameterization.
<b>Protective cover</b>	The protective cover protects the sensor housing against soiling and intense heat from solar radiation.
<b>Flanges</b>	Screwed flanges are available in different versions according to the following standards: DIN 2501, EN 1092-1, BS 10, ASME B 16.5, JIS B 2210-1984, GOST 12821-80.
<b>Welded sockets and adapters</b>	Welded sockets are used to connect the sensors to the process. Threaded adapters are used for adaptation of the sensor with threaded fitting G $\frac{3}{4}$ or G1 $\frac{1}{2}$ to existing welded sockets. You can find further information in the supplementary instructions " <i>Welded socket and adapters</i> " (Document-ID 48094).
<b>Electronics module</b>	Electronics module "VEGAPULS series 60" is a replacement part for radar sensors of VEGAPULS series 60. A different version is available for each type of signal output. You can find further information in the operating instructions " <i>Electronics module VEGAPULS series 60</i> " (Document-ID 36801).

## 4 Mounting

### 4.1 General instructions

#### Protection against moisture

Protect your instrument against moisture ingress through the following measures:

- Use a suitable connection cable (see chapter "*Connecting to power supply*")
- Tighten the cable gland or plug connector
- When mounting horizontally, turn the housing so that the cable gland or plug connector point downward
- Lead the connection cable downward in front of the cable entry or plug connector

This applies mainly to outdoor installations, in areas where high humidity is expected (e.g. through cleaning processes) and on cooled or heated vessels.

To maintain the housing protection, make sure that the housing lid is closed during operation and locked, if necessary.

Make sure that the degree of contamination specified in chapter "*Technical data*" meets the existing ambient conditions.

#### Process conditions

Make sure before mounting that all parts of the instrument exposed to the process are suitable for the existing process conditions.

These are mainly:

- Active measuring component
- Process fitting
- Process seal

Process conditions in particular are:

- Process pressure
- Process temperature
- Chemical properties of the medium
- Abrasion and mechanical influences

You can find detailed information on the process conditions in chapter "*Technical data*" as well as on the type label.

#### Second Line of Defense

As a standard feature, the VEGAPULS 64 is separate from the process through its plastic antenna encapsulation.

Optionally, the instrument is available with a Second Line of Defense (SLOD), a second process separation. It is located as gas-tight leadthrough between the process component and the electronics. This means additional safety against penetration of the medium from the process into the instrument.

### 4.2 Mounting versions, plastic horn antenna

#### Mounting strap

The optional mounting strap allows simple mounting of the instrument on a wall, ceiling or boom. Especially in the case of open vessels, this is a simple and effective way to align the sensor to the surface of the bulk solid material.

The following versions are available:

- Length 300 mm
- Length 170 mm

### Mounting strap - Ceiling mounting

The instrument is normally mounted vertically with a bracket on the ceiling.

This allows swivelling the sensor up to 180° for optimal orientation and rotating for optimal connection.

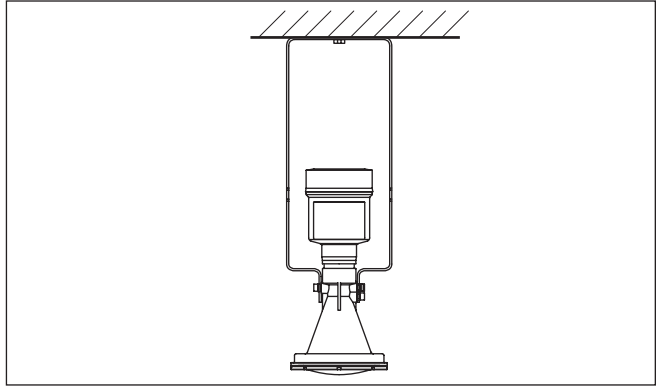

Fig. 3: Ceiling mounting via the mounting strap with length 300 mm

### Mounting strap - Wall mounting

As an alternative the strap mounting is carried out horizontally or obliquely.

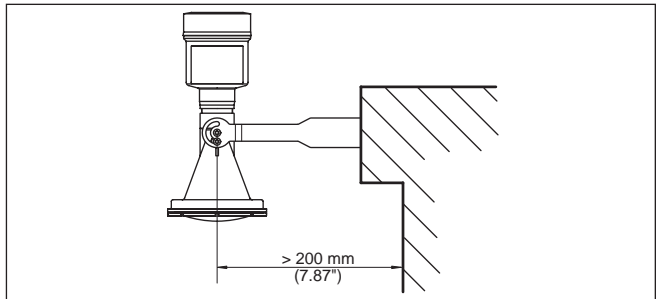

Fig. 4: Wall mounting horizontally via the mounting strap with length 170 mm



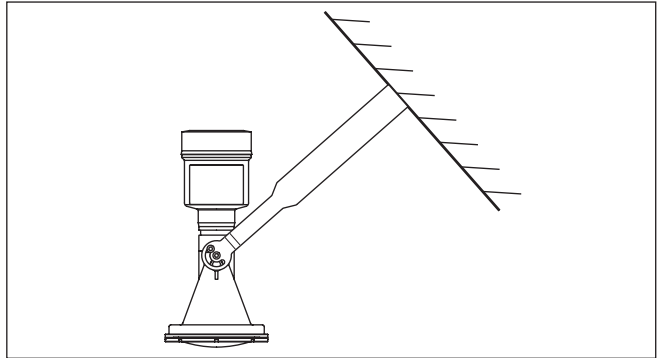

Fig. 5: Wall mounting with inclined wall via the mounting strap with length 300 mm

**Flange**

Two versions are available for mounting the instrument on a socket:

- Combi compression flange
- Adapter flange

**Combi compression flange**

The combi compression flange is suitable for different vessel flanges DN 80, ASME 3" and JIS 80. It comes not sealed against the radar sensor and can thus only be used unpressurized. It can be retrofitted on instruments with single chamber housing, retrofitting to a double chamber housing is not possible.

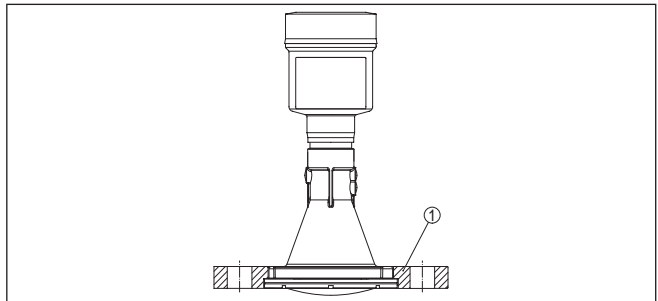

Fig. 6: Combi compression flange

1 Combi compression flange

**Adapter flange**

The adapter flange is available from DN 100, ASME 4" and JIS 100. It is permanently connected with the radar sensor and sealed.

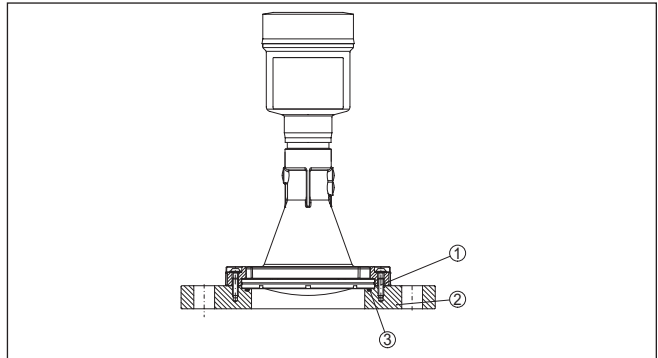

Fig. 7: Adapter flange

- 1 Connection screw
- 2 Adapter flange
- 3 Process seal

### 4.3 Mounting preparations, mounting strap

The mounting strap is supplied unassembled (optionally) and must be screwed to the sensor before setup with three hexagon socket screws M5 x 10 and spring washers. Max. torque, see chapter "Technical data". Required tools: Allen wrench size 4.

There are two different variants of screwing the strap to the sensor, see following illustration:

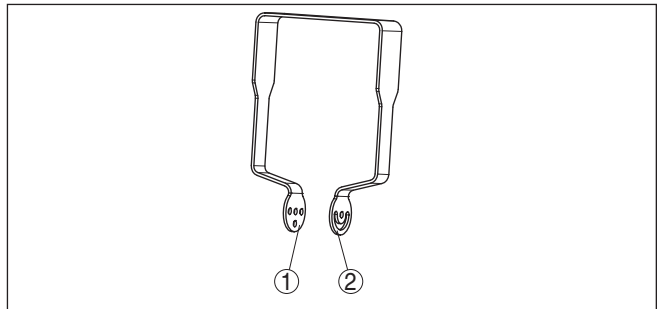

Fig. 8: Mounting strap for screwing to the sensor

- 1 For angle of inclination in steps
- 2 For angle of inclination, infinitely variable

Depending on the selected variant, the sensor can be rotated in the strap:

- Single chamber housing
  - Angle of inclination in three steps 0°, 90° and 180°
  - Angle of inclination 180°, infinitely variable
- Double chamber housing
  - Angle of inclination in two steps 0° and 90°
  - Angle of inclination 90°, infinitely variable

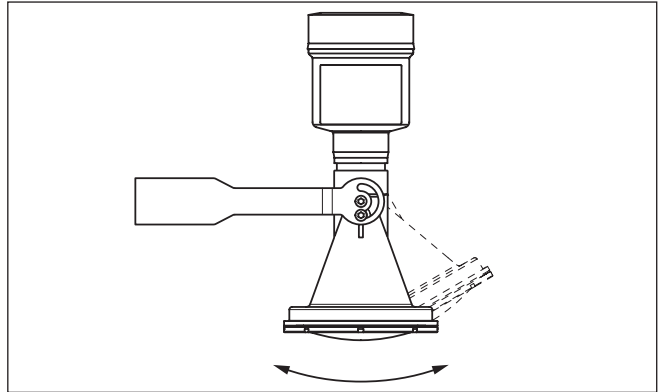

Fig. 9: Adjustment of the angle of inclination

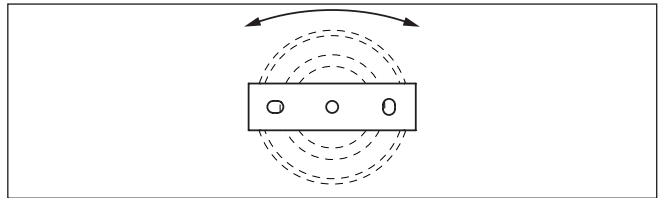

Fig. 10: Turning by fastening in the centre

### 4.4 Mounting instructions

#### Polarisation

Radar sensors for level measurement emit electromagnetic waves. The polarization is the direction of the electrical component of these waves.

The polarization direction is marked by a nose on the housing, see following drawing:

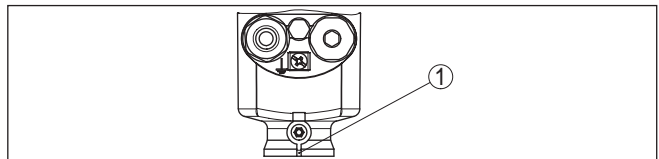

Fig. 11: Position of the polarisation

1 Nose for marking the direction of polarisation



**Note:**

When the housing is rotated, the direction of polarization changes and hence the influence of the false echo on the measured value. Please keep this in mind when mounting or making changes later.

#### Installation position

When mounting the sensor, keep a distance of at least 200 mm (7.874 in) from the vessel wall. If the sensor is installed in the center of dished or round vessel tops, multiple echoes can arise. However,

these can be suppressed by an appropriate adjustment (see chapter "Setup").

If you cannot maintain this distance, you should carry out a false signal suppression during setup. This applies particularly if buildup on the vessel wall is expected. In such cases, we recommend repeating the false signal suppression at a later date with existing buildup.

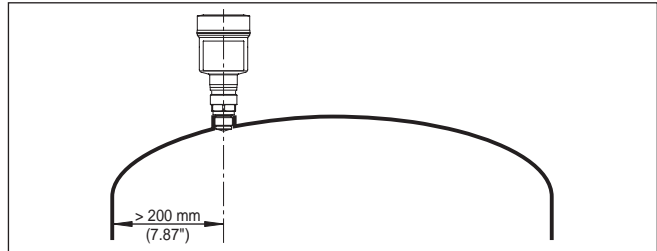

Fig. 12: Mounting of the radar sensor on round vessel tops

In vessels with conical bottom it can be advantageous to mount the sensor in the centre of the vessel, as measurement is then possible down to the bottom.

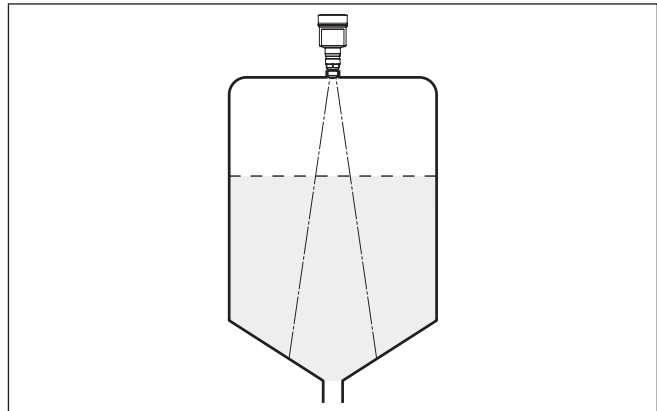

Fig. 13: Mounting of the radar sensor on vessels with conical bottom

## Reference plane

The measuring range of VEGAPULS 64 begins physically at the end of the antenna. The min./max. adjustment, however, begins at the reference plane. The reference plane is different depending on the sensor version.

- **Plastic horn antenna:** The reference plane is the sealing surface on the lower edge
- **Thread with integrated horn antenna:** The reference plane is the sealing surface at the bottom of the hexagon
- **Flange with encapsulated antenna system:** The reference plane is the lower edge of the flange plating
- **Hygienic fittings:** The reference plane is the highest contact point between sensor process fitting and welded socket

The following graphic shows the position of the reference plane with different sensor versions.

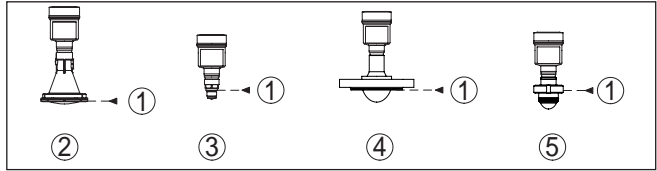

Fig. 14: Position of the reference plane

- 1 Reference plane
- 2 Plastic horn antenna
- 3 Threaded fittings
- 4 Flange connections
- 5 Hygienic fittings

**Inflowing medium**

Do not mount the instruments in or above the filling stream. Make sure that you detect the product surface, not the inflowing product.

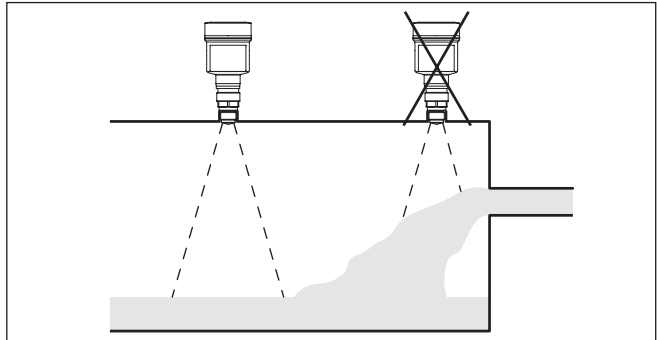

Fig. 15: Mounting of the radar sensor with inflowing medium

**Mounting socket**

For socket mounting, the socket should be as short as possible and its end rounded. This reduces false reflections from the socket.

With threaded connection, the antenna end should protrude at least 5 mm (0.2 in) out of the socket.

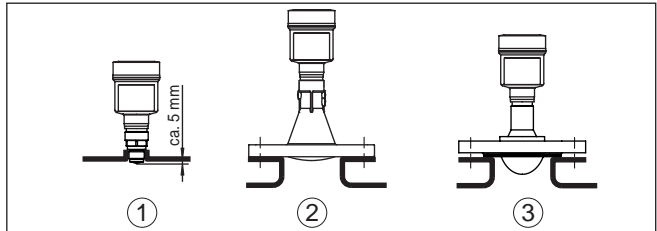

Fig. 16: Recommended socket mounting with different versions of VEGAPULS 64

- 1 Thread with integrated horn antenna
- 2 Plastic horn antenna
- 3 Flange with encapsulated antenna system

If the reflective properties of the medium are good, you can mount VEGAPULS 64 on sockets longer than the antenna. The socket end should be smooth and burr-free, if possible also rounded.



**Note:**

When mounting on longer sockets, we recommend carrying out a false signal suppression (see chapter "*Parameter adjustment*").

You will find recommended values for socket heights in the following illustration or the tables. The values come from typical applications. Deviating from the proposed dimensions, also longer sockets are possible, however the local conditions must be taken into account.

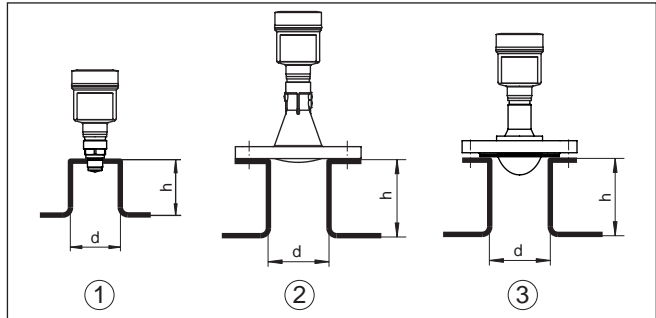

Fig. 17: Socket mounting with deviating socket dimensions with different versions of VEGAPULS 64

- 1 Thread with integrated horn antenna
- 2 Plastic horn antenna
- 3 Flange with encapsulated antenna system

**Thread with integrated horn antenna**

Socket diameter d		Socket length h	
40 mm	1½"	≤ 150 mm	≤ 5.9 in
50 mm	2"	≤ 200 mm	≤ 7.9 in
80 mm	3"	≤ 300 mm	≤ 11.8 in
100 mm	4"	≤ 400 mm	≤ 15.8 in
150 mm	6"	≤ 600 mm	≤ 23.6 in

**Plastic horn antenna**

Socket diameter d		Socket length h	
80 mm	3"	≤ 400 mm	≤ 15.8 in
100 mm	4"	≤ 500 mm	≤ 19.7 in
150 mm	6"	≤ 800 mm	≤ 31.5 in

**Flange with encapsulated antenna system**

Socket diameter d		Socket length h	
50 mm	2"	≤ 200 mm	≤ 7.9 in
80 mm	3"	≤ 400 mm	≤ 15.8 in
100 mm	4"	≤ 500 mm	≤ 19.7 in
150 mm	6"	≤ 800 mm	≤ 31.5 in

**Sealing to the process**

The VEGAPULS 64 with flange and encapsulated antenna system, the PTFE washer of the antenna encapsulation serves also as process seal.

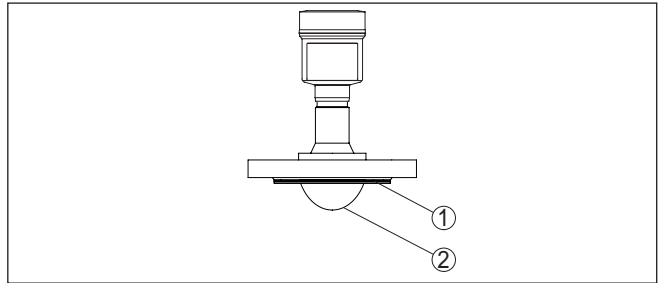

Fig. 18: VEGAPULS 64 with flange and encapsulated antenna system

- 1 PTFE washer
- 2 Antenna encapsulation

However, PTFE-plated flanges have a preload loss over time at high temperature changes.



**Note:**

Therefore, use disc springs to compensate for this preload loss during mounting. They are included in the scope of delivery of the instrument and are intended for the flange screws.

To seal effectively, the following requirements must be fulfilled:

1. Make sure the number of flange screws corresponds to the number of flange holes
2. Use of disc springs as previously described

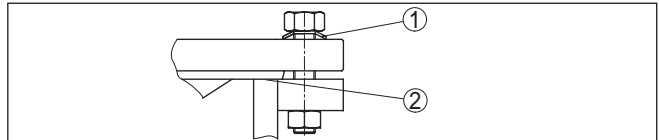

Fig. 19: Use of disc springs

- 1 Disc spring
- 2 Sealing surface

3. Tighten screws with the necessary torque (see chapter "Technical data", "Torques")

**Note:**

We recommend re-tightening the screws at regular intervals, depending on process pressure and temperature. Recommended torque, see chapter "Technical data", "Torques".

**Exchange, flange plating**

The PTFE washer in 8 mm version can be exchanged by the user in case of wear or damage.

Proceed as follows while dismantling:

1. Dismount and clean the instrument, note chapters "Dismounting steps" and "Maintenance"
2. Loosen the PTFE washer manually and detach it

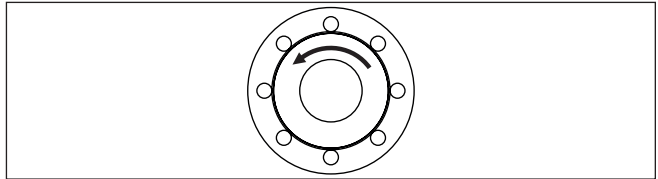

Fig. 20: VEGAPULS 64 - Loosening the PTFE washer

**Note:**

Protect the thread against contamination

3. Remove the sealing and clean the sealing groove
4. Insert the supplied new sealing, place the PTFE washer onto the thread and tighten it manually
5. Mount the sensor, tighten the flange screws (torque see chapter "Technical data", "Torques")

**Note:**

We recommend re-tightening the screws at regular intervals, depending on process pressure and temperature. Recommended torque, see chapter "Technical data", "Torques".

**Mounting, PTFE threaded adapter**

PTFE threaded adapters are available for VEGAPULS 64 with thread G1½ or 1½NPT. Due to this, only PTFE is in contact with the medium. Mount the PTFE threaded adapter in the following way:



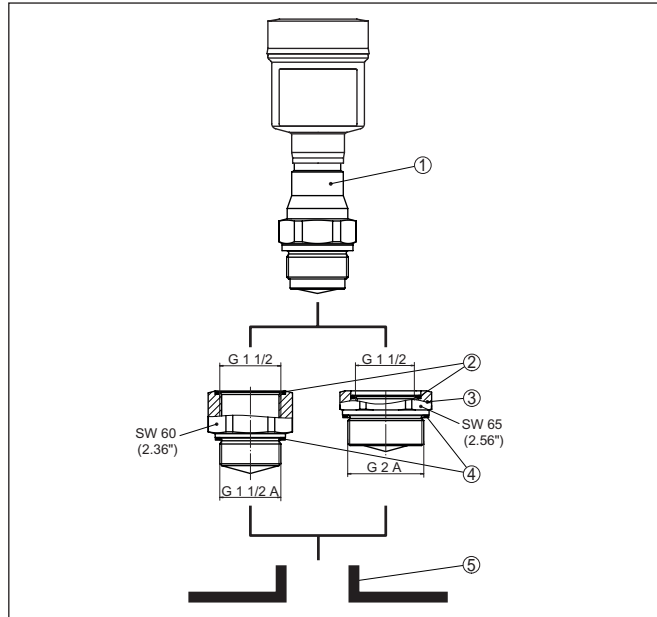

Fig. 21: VEGAPULS 64 with PTFE threaded adapter

- 1 Sensor
- 2 O-ring seal - sensor side
- 3 PTFE threaded adapter
- 4 Flat seal - process side
- 5 Welded socket

1. Remove existing Klingersil flat seal on the thread of VEGAPULS 64
2. Insert the supplied O-ring seal (1) into the threaded adapter
3. Place the supplied flat seal (4) onto the thread of the adapter



**Note:**

For the threaded adapter in NPT version, there is no flat seal required on the process side.

4. Screw the threaded adapter on the hexagon into the welded socket. Torque see chapter "Technical data"
5. Screw VEGAPULS 64 on the hexagon into the threaded adapter. Torque see chapter "Technical data"

**Mounting in the vessel insulation**

Instruments for a temperature range up to 200 °C have a spacer for temperature decoupling between process fitting and electronics housing.



**Note:**

The spacer may only be incorporated up to a maximum of 40 mm into the vessel insulation. Only then is a reliable temperature decoupling guaranteed.

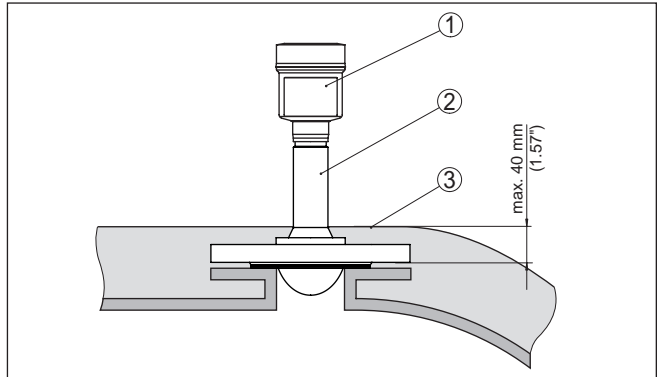

Fig. 22: Mounting the instrument on insulated vessels.

- 1 Electronics housing
- 2 Spacer
- 3 Vessel insulation

### Vessel installations

The mounting location of the radar sensor should be a place where no other equipment or fixtures cross the path of the radar signals.

Vessel installations, such as e.g. ladders, limit switches, heating spirals, struts, etc., can cause false echoes and impair the useful echo. Make sure when planning your measuring point that the radar sensor has a "clear view" to the measured product.

In case of existing vessel installations, a false signal suppression should be carried out during setup.

If large vessel installations such as struts or supports cause false echoes, these can be attenuated through supplementary measures. Small, inclined sheet metal baffles above the installations scatter the radar signals and prevent direct interfering reflections.

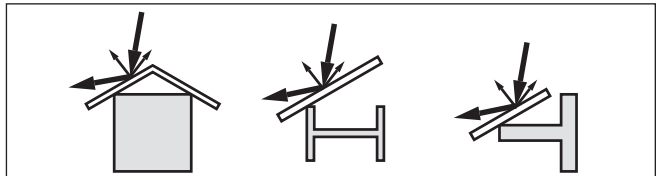

Fig. 23: Cover flat, large-area profiles with deflectors

### Sensor orientation

In liquids, direct the sensor as perpendicular as possible to the product surface to achieve optimum measurement results.

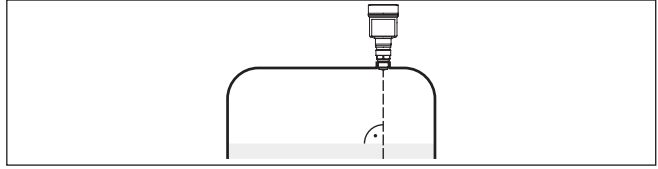

Fig. 24: Alignment in liquids

## Agitators

If there are agitators in the vessel, a false signal suppression should be carried out with the agitators in motion. This ensures that the interfering reflections from the agitators are saved with the blades in different positions.

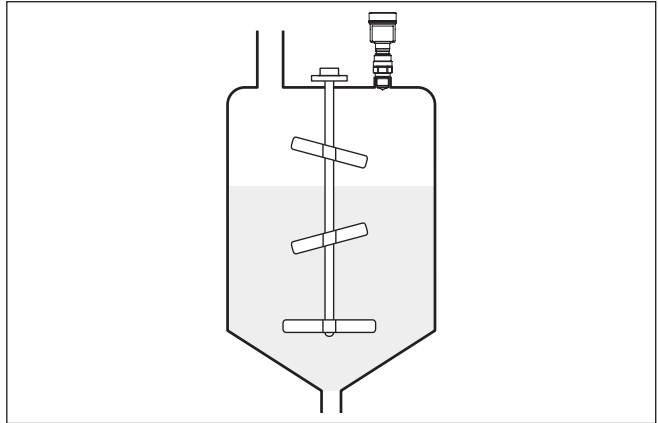

Fig. 25: Agitators

## Foam generation

Through the action of filling, stirring and other processes in the vessel, compact foams which considerably damp the emitted signals may form on the product surface.

If foams lead to measurement errors, you should use the biggest possible radar antennas or sensors with guided microwave.

## 4.5 Measurement setup - Flow

In general, the following must be observed while mounting the sensor:

- Mounting the sensor on the upstream or inlet side
- Installation in the centre of the flume and vertical to the liquid surface
- Distance to the overflow orifice or Venturi flume
- Minimum distance to the max. height of damming

The following examples are used as an overflow of the flow measurement, detailed planning information is available from the flume manufacturers and in special literature.

## Rectangular overflow

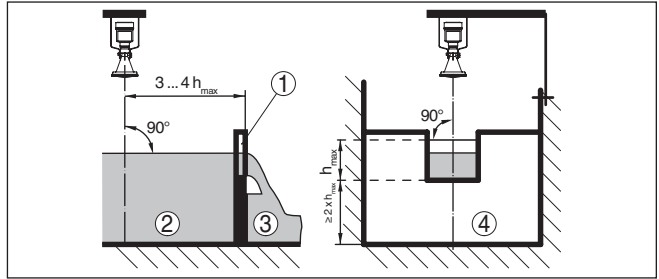

Fig. 26: Flow measurement with rectangular flume:  $h_{max}$  = max. filling of the rectangular flume

- 1 Overflow orifice (side view)
- 2 Headwater
- 3 Tailwater
- 4 Overflow orifice (view from tailwater)

## Khafagi-Venturi flume

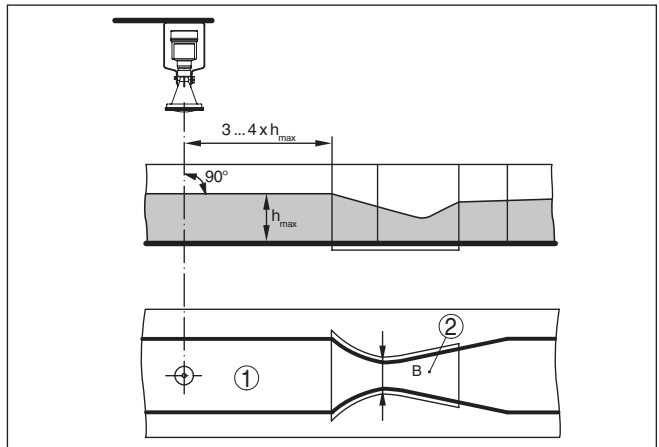

Fig. 27: Flow measurement with Khafagi-Venturi flume:  $h_{max}$  = max. filling of the flume;  $B$  = tightest constriction in the flume

- 1 Position sensor
- 2 Venturi flume

## 5 Connecting to power supply

### 5.1 Preparing the connection

#### Safety instructions

Always keep in mind the following safety instructions:

- Carry out electrical connection by trained, qualified personnel authorised by the plant operator
- If overvoltage surges are expected, overvoltage arresters should be installed



#### Warning:

Connect only in the complete absence of line voltage.

#### Voltage supply

Power supply and current signal are carried on the same two-wire cable. The operating voltage can differ depending on the instrument version.

The data for power supply are specified in chapter "*Technical data*".

Provide a reliable separation between the supply circuit and the mains circuits according to DIN EN 61140 VDE 0140-1.

Power the instrument via an energy-limited circuit acc. to IEC 61010-1, e.g. via Class 2 power supply unit.

Keep in mind the following additional factors that influence the operating voltage:

- Lower output voltage of the power supply unit under nominal load (e.g. with a sensor current of 20.5 mA or 22 mA in case of fault)
- Influence of additional instruments in the circuit (see load values in chapter "*Technical data*")

#### Connection cable

The instrument is connected with standard two-wire cable without screen. If electromagnetic interference is expected which is above the test values of EN 61326-1 for industrial areas, screened cable should be used.

Use cable with round cross section for instruments with housing and cable gland. Use a cable gland suitable for the cable diameter to ensure the seal effect of the cable gland (IP protection rating).

Screened cable generally necessary in HART multidrop mode.

#### Cable glands

##### Metric threads

In the case of instrument housings with metric thread, the cable glands are screwed in at the factory. They are sealed with plastic plugs as transport protection.

You have to remove these plugs before electrical connection.

##### NPT thread

In the case of instrument housings with self-sealing NPT threads, it is not possible to have the cable entries screwed in at the factory. The free openings for the cable glands are therefore covered with red dust protection caps as transport protection.

Prior to setup you have to replace these protective caps with approved cable glands or close the openings with suitable blind plugs.

On plastic housings, the NPT cable gland or the Conduit steel tube must be screwed into the threaded insert without grease.

Max. torque for all housings, see chapter "*Technical data*".

### Cable screening and grounding

If screened cable is required, the cable screening must be connected on both ends to ground potential. In the sensor, the cable screening is connected directly to the internal ground terminal. The ground terminal on the outside of the housing must be connected to the ground potential (low impedance).



In Ex systems, the grounding is carried out according to the installation regulations.

In electroplating plants as well as plants for cathodic corrosion protection it must be taken into account that significant potential differences exist. This can lead to unacceptably high currents in the cable screen if it is grounded at both ends.



#### Information:

The metallic parts of the instrument (process fitting, sensor, concentric tube, etc.) are connected with the internal and external ground terminal on the housing. This connection exists either directly via the conductive metallic parts or, in case of instruments with external electronics, via the screen of the special connection cable.

You can find specifications on the potential connections inside the instrument in chapter "*Technical data*".

## 5.2 Connecting

### Connection technology

The voltage supply and signal output are connected via the spring-loaded terminals in the housing.

Connection to the display and adjustment module or to the interface adapter is carried out via contact pins in the housing.



#### Information:

The terminal block is pluggable and can be removed from the electronics. To do this, lift the terminal block with a small screwdriver and pull it out. When reinserting the terminal block, you should hear it snap in.

### Connection procedure

Proceed as follows:

1. Unscrew the housing lid
2. If a display and adjustment module is installed, remove it by turning it slightly to the left
3. Loosen compression nut of the cable gland and remove blind plug
4. Remove approx. 10 cm (4 in) of the cable mantle, strip approx. 1 cm (0.4 in) of insulation from the ends of the individual wires
5. Insert the cable into the sensor through the cable entry

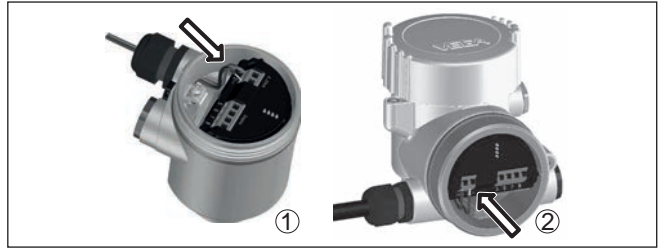

Fig. 28: Connection steps 5 and 6

- 1 Single chamber housing
- 2 Double chamber housing

6. Insert the wire ends into the terminals according to the wiring plan



**Information:**

Solid cores as well as flexible cores with wire end sleeves are inserted directly into the terminal openings. In case of flexible cores without end sleeves, press the terminal from above with a small screwdriver, the terminal opening is then free. When the screwdriver is released, the terminal closes again.

You can find further information on the max. wire cross-section under "Technical data - Electromechanical data".

- 7. Check the hold of the wires in the terminals by lightly pulling on them
- 8. Connect the screen to the internal ground terminal, connect the external ground terminal to potential equalisation
- 9. Tighten the compression nut of the cable entry gland. The seal ring must completely encircle the cable
- 10. Reinsert the display and adjustment module, if one was installed
- 11. Screw the housing lid back on

The electrical connection is finished.

**5.3 Wiring plan, single chamber housing**



The following illustration applies to the non-Ex as well as to the Ex-ia version.

### Electronics and connection compartment

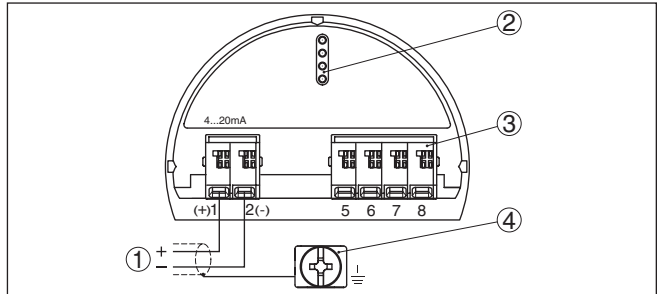

Fig. 29: Electronics and connection compartment - single chamber housing

- 1 Voltage supply, signal output
- 2 For display and adjustment module or interface adapter
- 3 For external display and adjustment unit
- 4 Ground terminal for connection of the cable screening

### 5.4 Wiring plan, double chamber housing



The following illustrations apply to the non-Ex as well as to the Ex-ia version.

### Electronics compartment

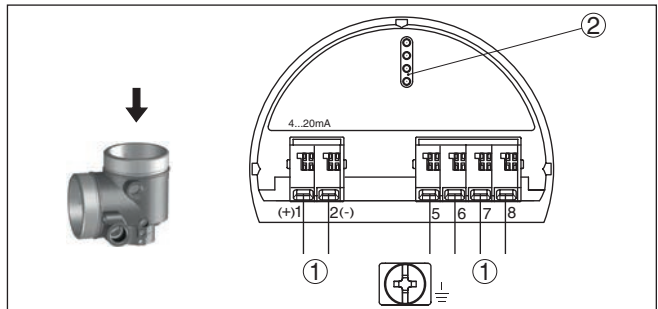

Fig. 30: Electronics compartment - double chamber housing

- 1 Internal connection to the connection compartment
- 2 For display and adjustment module or interface adapter



Connection compartment

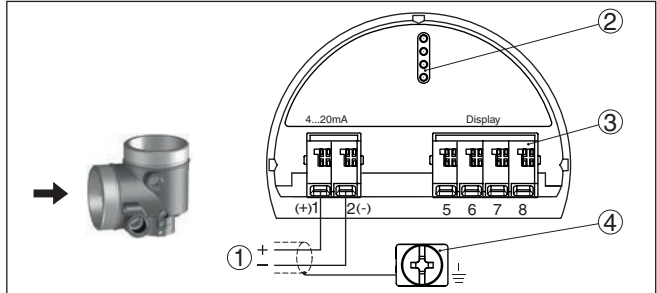

Fig. 31: Connection compartment - double chamber housing

- 1 Voltage supply, signal output
- 2 For display and adjustment module or interface adapter
- 3 For external display and adjustment unit
- 4 Ground terminal for connection of the cable screening

Connection compartment - Radio module PLICSMOBILE 81

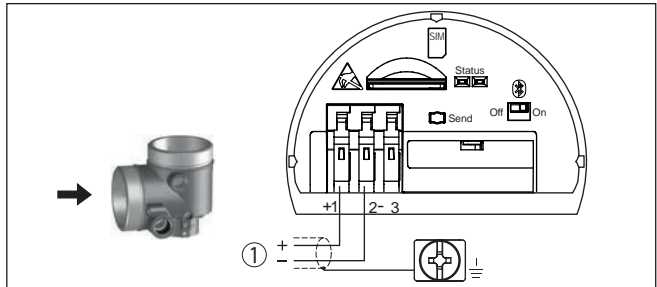

Fig. 32: Connection compartment - Radio module PLICSMOBILE 81

- 1 Voltage supply

You can find detailed information for connection in the operating instructions "PLICSMOBILE".

5.5 Wiring plan - version IP 66/IP 68, 1 bar

Wire assignment, connection cable

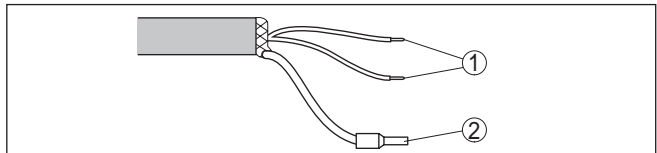

Fig. 33: Wire assignment in permanently connected connection cable

- 1 Brown (+) and blue (-) to power supply or to the processing system
- 2 Shielding

5.6 Switch-on phase

After connecting the instrument to voltage supply or after a voltage recurrence, the instrument carries out a self-check for approx. 30 s:

- Internal check of the electronics
- Indication of the instrument type, hardware and software version, measurement loop name on the display or PC
- Indication of the status message "*F 105 Determine measured value*" on the display or PC
- The output signal jumps to the set fault current

As soon as a plausible measured value is found, the corresponding current is output to the signal cable. The value corresponds to the actual level as well as the settings already carried out, e.g. factory setting.

## 6 Set up with the display and adjustment module

### 6.1 Insert display and adjustment module

The display and adjustment module can be inserted into the sensor and removed again at any time. You can choose any one of four different positions - each displaced by 90°. It is not necessary to interrupt the power supply.

Proceed as follows:

1. Unscrew the housing lid
2. Place the display and adjustment module on the electronics in the desired position and turn it to the right until it snaps in.
3. Screw housing lid with inspection window tightly back on

Disassembly is carried out in reverse order.

The display and adjustment module is powered by the sensor, an additional connection is not necessary.



Fig. 34: Installing the display and adjustment module in the electronics compartment of the single chamber housing

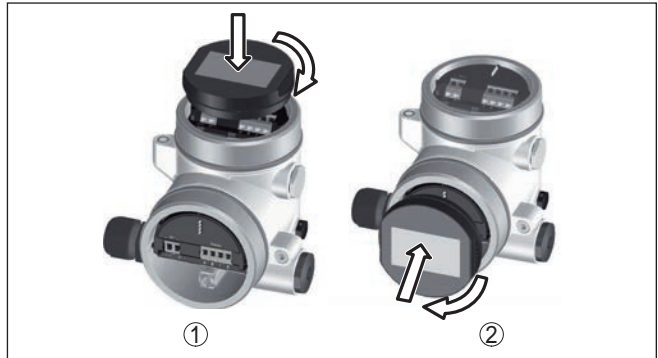

Fig. 35: Installing the display and adjustment module in the double chamber housing

- 1 In the electronics compartment
- 2 In the connection compartment



**Note:**

If you intend to retrofit the instrument with a display and adjustment module for continuous measured value indication, a higher lid with an inspection glass is required.

## 6.2 Adjustment system

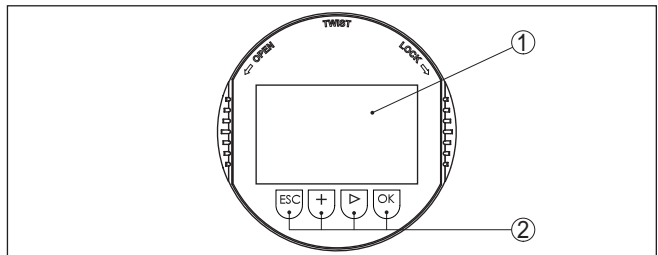

Fig. 36: Display and adjustment elements

- 1 LC display
- 2 Adjustment keys

### Key functions

- **[OK]** key:
  - Move to the menu overview
  - Confirm selected menu
  - Edit parameter
  - Save value
- **[->]** key:
  - Change measured value presentation
  - Select list entry
  - Select menu items
  - Select editing position
- **[+]** key:

- Change value of the parameter

- **[ESC]** key:

- Interrupt input
- Jump to next higher menu

**Operating system - Keys direct**

The instrument is operated via the four keys of the display and adjustment module. The individual menu items are shown on the LC display. You can find the function of the individual keys in the previous illustration.

**Adjustment system - keys via magnetic pen**

With the Bluetooth version of the display and adjustment module you can also adjust the instrument with the magnetic pen. The pen operates the four keys of the display and adjustment module right through the closed lid (with inspection window) of the sensor housing.

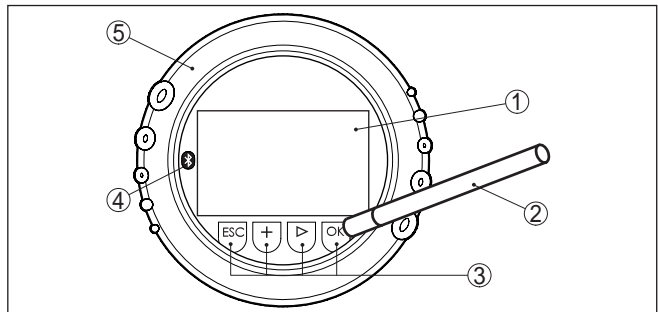

Fig. 37: Display and adjustment elements - with adjustment via magnetic pen

- 1 LC display
- 2 Magnetic pen
- 3 Adjustment keys
- 4 Bluetooth symbol
- 5 Lid with inspection window

**Time functions**

When the **[+]** and **[->]** keys are pressed quickly, the edited value, or the cursor, changes one value or position at a time. If the key is pressed longer than 1 s, the value or position changes continuously.

When the **[OK]** and **[ESC]** keys are pressed simultaneously for more than 5 s, the display returns to the main menu. The menu language is then switched over to "English".

Approx. 60 minutes after the last pressing of a key, an automatic reset to measured value indication is triggered. Any values not confirmed with **[OK]** will not be saved.

**6.3 Measured value indication - Selection of national language**

With the **[->]** key you move between three different indication modes. In the first view, the selected measured value is displayed in large digits.

**Measured value indication**

In the second view, the selected measured value and a corresponding bar graph presentation are displayed.

In the third view, the selected measured value as well as a second selectable value, e.g. the temperature of the electronics, are displayed.

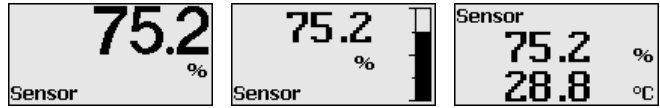

During the initial setup of an instrument shipped with factory settings, use the "OK" key to get to the menu "National language".

### Selection of national language

This menu item is used to select the national language for further parameter adjustment. You can change the selection via the menu item "Setup - Display, Menu language".

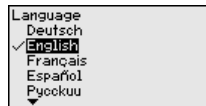

With the "OK" key you move to the main menu.

## 6.4 Parameter adjustment - Quick setup

To quickly and easily adapt the sensor to the application, select the menu item "Quick setup" in the start graphic on the display and adjustment module.



Select the individual steps with the [->] key.

After the last step, "Quick setup terminated successfully" is displayed briefly.



### Information:

The echo curve of setup is stored automatically during the quick setup.

The return to the measured value indication is carried out through the [->] or [ESC] keys or automatically after 3 s

You can find "Extended adjustment" in the next sub-chapter.

## 6.5 Parameter adjustment - Extended adjustment

The main menu is divided into five sections with the following functions:

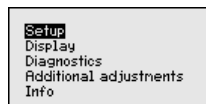

**Setup:** Settings, e.g., for measurement loop name, units, application, adjustment, signal output

### Main menu

**Display:** Settings, e.g., for language, measured value display, lighting

**Diagnosis:** Information, for example, on device status, peak value, simulation, echo curve

**Additional adjustments:** Date/Time, reset, copy function, scaling, current output, false signal suppression, linearization, HART mode, special parameters

**Info:** Instrument name, hardware and software version, calibration date, instrument features

In the main menu item "Setup", the individual submenu items should be selected one after the other and provided with the correct parameters to ensure optimum adjustment of the measurement. The procedure is described in the following.

**Setup - Measurement loop name**

Here you can assign a suitable measurement loop name. Push the "OK" key to start the editing. With the "+" key you change the sign and with the "->" key you jump to the next position.

You can enter names with max. 19 characters. The character set comprises:

- Capital letters from A ... Z
- Numbers from 0 ... 9
- Special characters + - / \_ blanks

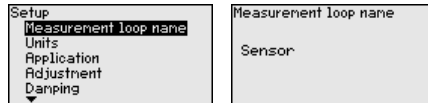

**Setup - Units**

In this menu item you select the distance unit and the temperature unit.

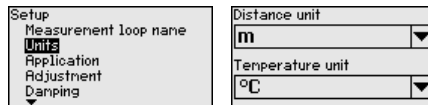

For the distance units you can choose between m, in and ft and for the temperature units °C, °F and K.

**Setup - Application**

This menu item allows you to adapt the sensor to the measuring conditions.

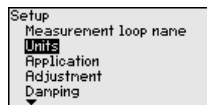

**Medium**

The following options are available:

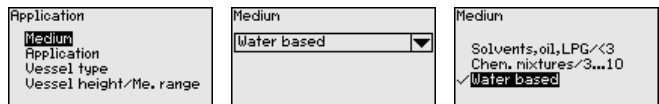

## Application

The following options are available:

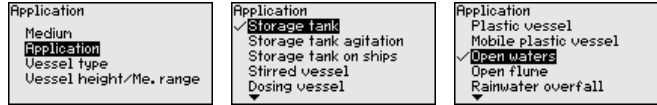

The following features form the basis of the applications:

### Storage tank

- Setup: large-volumed, upright cylindrical, spherical
- Medium speed: slow filling and emptying
- Process/measurement conditions:
  - Condensation
  - Smooth product surface
  - High requirements on measurement accuracy
- Properties, sensor:
  - Low sensitivity to sporadic false echoes
  - Stable and reliable measured values through averaging
  - High measurement accuracy
  - Short reaction time of the sensor not required

### Storage tank with product circulation

- Setup: large-volumed, upright cylindrical, spherical
- Medium speed: slow filling and emptying
- Installations: small, laterally mounted or large, top mounted stirrer
- Process/measurement conditions:
  - Relatively smooth product surface
  - High requirements on measurement accuracy
  - Condensation
  - Slight foam generation
  - Overfilling possible
- Properties, sensor:
  - Low sensitivity to sporadic false echoes
  - Stable and reliable measured values through averaging
  - High measurement accuracy, because not set for max. speed
  - False signal suppression recommended

### Storage tank on ships (Cargo Tank)

- Medium speed: slow filling and emptying
- Vessel:
  - Installations in the bottom section (bracers, heating spirals)
  - High sockets 200 ... 500 mm, also with large diameters
- Process/measurement conditions:
  - Condensation, buildup by movement
  - Max. requirement on measurement accuracy from 95 %
- Properties, sensor:
  - Low sensitivity to sporadic false echoes
  - Stable and reliable measured values through averaging
  - High measurement accuracy
  - False signal suppression required



**Stirrer vessel (reactor)**

- Setup: all vessel sizes possible
- Medium speed:
  - Fast to slow filling possible
  - Vessel is filled and emptied very often
- Vessel:
  - Socket available
  - Large agitator blades of metal
  - Vortex breakers, heating spirals
- Process/measurement conditions:
  - Condensation, buildup by movement
  - Strong spout generation
  - Very agitated surface, foam generation
- Properties, sensor:
  - Higher measurement speed through less averaging
  - Sporadic false echoes are suppressed

**Dosing vessel**

- Setup: all vessel sizes possible
- Medium speed:
  - Fast filling and emptying
  - Vessel is filled and emptied very often
- Vessel: tight installation situation
- Process/measurement conditions:
  - Condensation, buildup on the antenna
  - Foam generation
- Properties, sensor:
  - Measurement speed optimized by virtually no averaging
  - Sporadic false echoes are suppressed
  - False signal suppression recommended

**Plastic tank**

- Vessel:
  - Instrument fix mounted or built in
  - Measurement through the vessel top, if appropriate to the application
  - With empty vessel, the measurement can go through the bottom
- Process/measurement conditions:
  - Condensation on the plastic ceiling
  - In outdoor facilities, water and snow on vessel top possible
- Properties, sensor:
  - False signals outside the vessel are not taken into consideration
  - False signal suppression recommended

For operation of the instrument in plastic tanks, certain conditions must be fulfilled (see chapter "*Radio licenses*" for Europe, USA and Canada).

**Transportable plastic tank**

- Vessel:
  - Material and thickness different
  - Measurement through the vessel top

- Process/measurement conditions:
  - Measured value jump with vessel change
- Properties, sensor:
  - Quick adaptation to changing reflection conditions due to vessel change
  - False signal suppression required

For operation of the instrument in plastic tanks, certain conditions must be fulfilled (see chapter "*Radio licenses*" for Europe, USA and Canada).

#### **Open water (gauge measurement)**

- Rate of level change: slow level change
- Process/measurement conditions:
  - Large distance from sensor to water surface
  - Extreme damping of output signal due to wave generation
  - Ice and condensation on the antenna possible
  - Spiders and insects build nests in the antennas
  - Floating material and animals sporadically appear on water surface
- Properties, sensor:
  - Stable and reliable measured values through frequent averaging
  - Insensitive in the close range

#### **Open flume (flow measurement)**

- Rate of level change: slow level change
- Process/measurement conditions:
  - Ice and condensation on the antenna possible
  - Spiders and insects build nests in the antennas
  - Smooth water surface
  - Exact measurement result required
  - Distance to the water surface normally relatively large
- Properties, sensor:
  - Stable and reliable measured values through frequent averaging
  - Insensitive in the close range

#### **Rain water spillover (weir)**

- Rate of level change: slow level change
- Process/measurement conditions:
  - Ice and condensation on the antenna possible
  - Spiders and insects build nests in the antennas
  - Turbulent water surface
  - Sensor flooding possible
- Properties, sensor:
  - Stable and reliable measured values through frequent averaging
  - Insensitive in the close range

#### **Demonstration**

- Adjustment for all applications which are not typically level measurement

- Instrument demonstration
- Object recognition/monitoring (additional settings required)
- Properties, sensor:
  - Sensor accepts all measured value changes within the measuring range immediately
  - High sensitivity to interference, because virtually no averaging

**Vessel form**

Apart from the medium and the application, the vessel form itself can influence the measurement. To adapt the sensor to these measuring conditions, this menu item offers different options for vessel bottom and ceiling for certain applications.

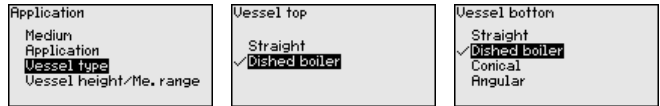

Enter the requested parameters via the appropriate keys, save your settings with **[OK]** and jump to the next menu item with the **[ESC]** and the **[->]** key.

**Vessel height/Measuring range**

Through this selection the operating range of the sensor is adapted to the vessel height, which considerably increases measurement reliability under different basic conditions.

The min. adjustment must be carried out independently of this.

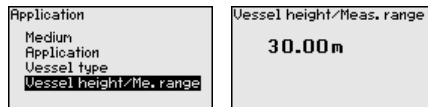

Enter the requested parameters via the appropriate keys, save your settings with **[OK]** and jump to the next menu item with the **[ESC]** and the **[->]** key.



**Caution:**

If liquids with different dielectric constants separate in the vessel, for example through condensation, the radar sensor can detect under certain circumstances only the medium with the higher dielectric constant. Keep in mind that layer interfaces can cause faulty measurements.

If you want to measure the total height of both liquids reliably, please contact our service department or use an instrument specially designed for interface measurement.

**Setup - Adjustment**

Since the radar sensor is a distance measuring instrument, it is the distance from the sensor to the product surface that is measured. To indicate the actual level, the measured distance must be assigned to a certain height percentage.

To perform the adjustment, enter the distance with full and empty vessel, see the following example:

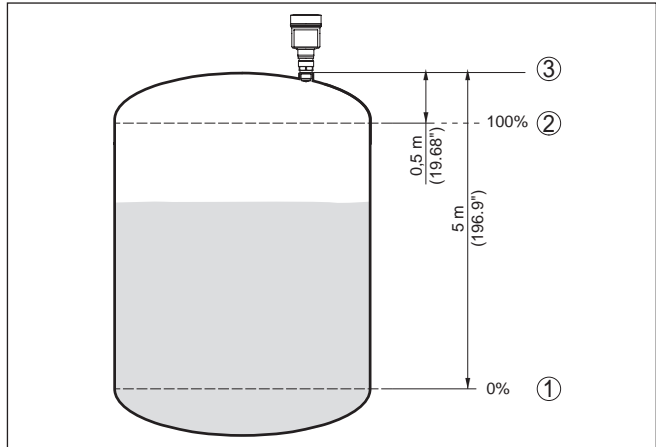

Fig. 38: Parameterisation example, Min./max. adjustment

- 1 Min. level = max. measuring distance
- 2 Max. level = min. measuring distance
- 3 Reference plane

If these values are not known, an adjustment with the distances of e.g. 10 % and 90 % is possible. Starting point for these distance specifications is always the sealing surface of the thread or flange. You can find specifications on the reference plane in chapter "Technical data". The actual level is calculated on the basis of these settings.

The actual product level during this adjustment is not important, because the min./max. adjustment is always carried out without changing the product level. These settings can be made ahead of time without the instrument having to be installed.

## Setup - Max. adjustment

Proceed as follows:

1. Select with **[->]** the menu item Max. adjustment and confirm with **[OK]**.

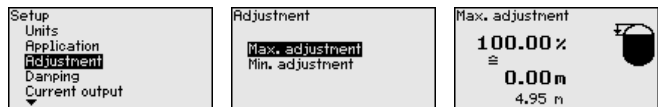

2. Prepare the percentage value for editing with **[OK]** and set the cursor to the requested position with **[->]**.

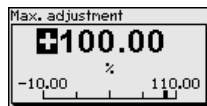

3. Set the requested percentage value with **[+]** and save with **[OK]**. The cursor jumps now to the distance value.

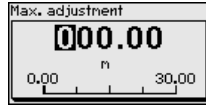

4. Enter the corresponding distance value in meters for the full vessel.
5. Save settings with **[OK]** and move with **[ESC]** and **[->]** to Min. adjustment.

**Setup - Min. adjustment**

Proceed as follows:

1. Select with **[->]** the menu item "Min. adjustment" and confirm with **[OK]**.

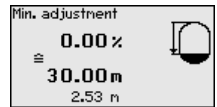
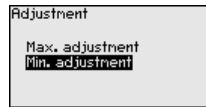
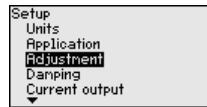

2. Edit the percentage value with **[OK]** and set the cursor to the requested position with **[->]**.

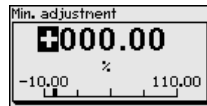

3. Set the requested percentage value with **[+]** and save with **[OK]**. The cursor jumps now to the distance value.

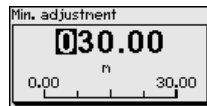

4. Enter the suitable distance value in m for empty vessel (e.g. distance from the sensor to the vessel bottom) corresponding to the percentage value.

**Setup - Damping**

To damp process-dependent measured value fluctuations, set an integration time of 0 ... 999 s in this menu item.

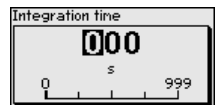
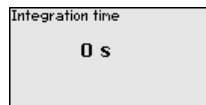
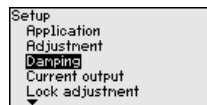

The default setting is a damping of 0 s.

**Setup - Current output, mode**

In the menu item "Current output mode" you determine the output characteristics and reaction of the current output in case of fault.

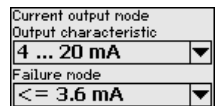
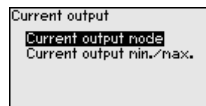
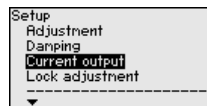

The default setting is output characteristics 4 ... 20 mA, fault mode < 3.6 mA.

### Setup - Current output Min./Max.

In the menu item "Current output Min./Max.", you determine the reaction of the current output during operation.

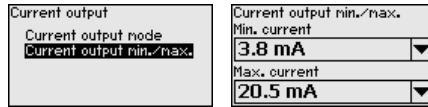

The default setting is min. current 3.8 mA and max. current 20.5 mA.

### Lock/unlock setup - Adjustment

In the menu item "Lock/unlock adjustment" you safeguard the sensor parameters against unauthorized or unintentional modifications.

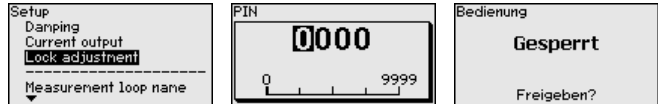

With active PIN, only the following adjustment functions are possible without entering a PIN:

- Select menu items and show data
- Read data from the sensor into the display and adjustment module

Releasing the sensor adjustment is also possible in any menu item by entering the PIN.



#### Caution:

With active PIN, adjustment via PACTware/DTM and other systems is also blocked.

### Display - Menu language

This menu item enables the setting of the requested national language.

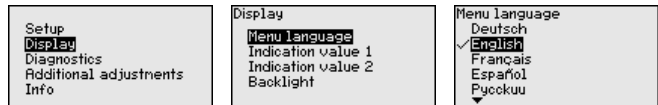

The following languages are available:

- German
- English
- French
- Spanish
- Russian
- Italian
- Dutch
- Portuguese
- Japanese
- Chinese
- Polish
- Czech
- Turkish

In the delivery status, the VEGAPULS 64 is set to the ordered national language.

## Display - Displayed value 1 and 2

In this menu item you can define the way measured values are indicated on the display.

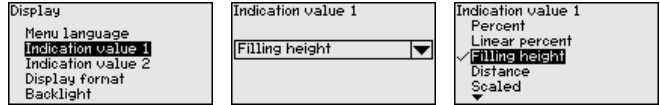

The default setting for the displayed value is "Distance".

## Display - Display format

In this menu item you define the number of decimal positions with which the measured value is displayed.

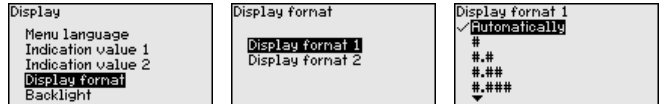

The default setting for the display format is "Automatic".

## Display - Backlight

The display and adjustment module has a backlight for the display. In this menu item you can switch the lighting on or off. You can find the required operating voltage in chapter "Technical data".

To maintain the function of the device, the lighting is temporarily switched off if the power supply is insufficient.

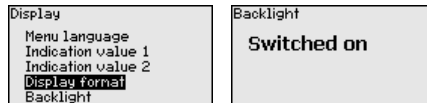

In delivery status, the lighting is switched on.

## Diagnostics - Device status

In this menu item, the device status is displayed.

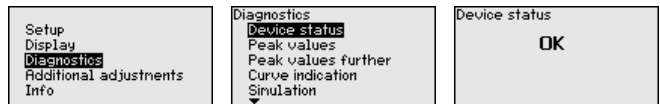

## Diagnosis - Peak value

The min. and max. measured value, the measurement reliability as well as the min. and max. electronics temperature are stored in the sensor. The values are displayed in menu item "Peak value" or "Further peak values".

A reset menu is opened with the [OK] key in the respective peak value window:

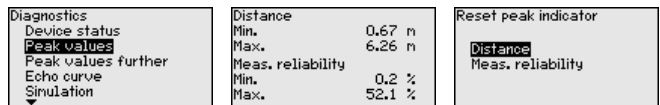

With the [OK] key in the reset menu, the peak values are reset to the current measured value.

## Diagnosis - Curve indication

The "Echo curve" shows the signal strength of the echoes over the measuring range in dB. The signal strength enables an evaluation of the quality of the measurement.

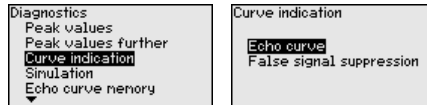

The selected curve is continuously updated. A submenu with zoom functions is opened with the **[OK]** key:

- "X-Zoom": Zoom function for the meas. distance
- "Y-Zoom": 1, 2, 5 and 10x signal magnification in "dB"
- "Unzoom": Reset the presentation to the nominal measuring range without magnification

## Diagnosis - Simulation

In this menu item you can simulate measured values via the current output. This allows the signal path to be tested, e.g. through downstream indicating instruments or the input card of the control system.

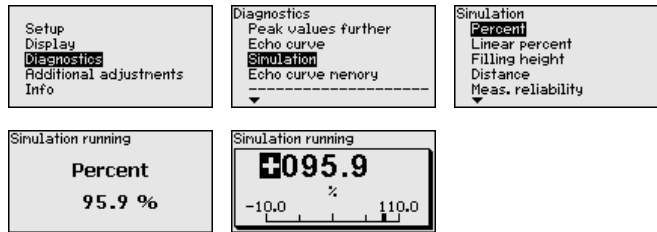

Select the requested simulation variable and set the requested value.



### Caution:

During simulation, the simulated value is output as 4 ... 20 mA current value and as digital HART signal. The status message within the context of the asset management function is "Maintenance".

To deactivate the simulation, you have to push the **[ESC]** key and confirm the message

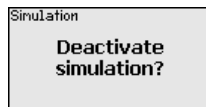

with the **[OK]** key.



### Information:

The sensor terminates the simulation automatically after 60 minutes.

## Diagnostics - Echo curve memory

The function "Setup" allows the echo curve to be saved at the time of setup.



### Information:

This is generally recommended, however, for use of the Asset Management functions it is absolutely necessary. Saving should be carried out with a very low level.

The function "Echo curve memory" allows up to ten individual echo curves to be stored, for example to detect the measurement behaviour of the sensor in different operating conditions.



With the adjustment software PACTware and the PC, the stored echo curves can be displayed with high resolution and used to recognize signal changes over time. In addition, the echo curve saved during setup can also be displayed in the echo curve window and compared with the current echo curve.

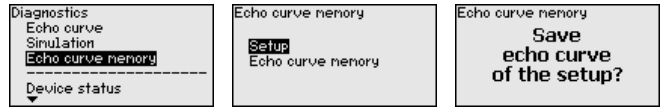

**Additional settings - Date/Time**

In this menu item, the internal clock of the sensor is set to the requested time and time format. At the time of shipment from factory, the instrument is set to CET (Central European Time).

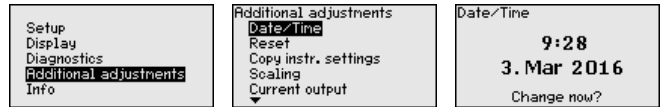

**Additional settings - Reset**

During a reset, the parameter settings carried out by the user are reset to the default values (see below table).

Proceed as follows:

1. Select with **[->]** under "Additional adjustments" the menu item "Reset" and confirm with **[OK]**.

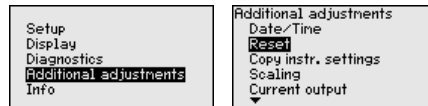

2. Confirm with **[OK]** and select the requested reset function with **[->]**



3. Confirm with **[OK]**, for approx. 5 s the message "Resetting" is displayed, then the selection window appears.



**Caution:**

For the duration of the reset, the set trouble signal is output via the current output. Within the context of the asset management function, the message "Maintenance" is output.

The following reset functions are available:

**Delivery status:** Restores the parameter settings at the time of shipment from the factory, incl. the order-specific settings. Any created false signal suppression, user-programmable linearization curve as

well as measured value and echo curve memory is deleted. The event and parameter modification memories remain unaffected.

**Basic settings:** Resets the parameter settings, incl. special parameters, to the default values of the respective instrument. Any stored false signal suppression or user programmable linearisation curve, as well as the measured value memory, is deleted. Order-related settings are not taken over into the current parameters after this reset.

The following table shows the scope of the reset function and the default values of the instrument:

Menu	Menu item	Default value
Setup	Measurement loop name	Sensor
	Units	Distance in m Temperature in °C
	Application	Medium: Water solution Application: Storage tank Vessel top: Dished form Vessel bottom: Dished form Vessel height/Measuring range: 30 m
	Min. adjustment	30 m
	Max. adjustment	0,000 m(d)
	Damping	0.0 s
	Current output mode	Output characteristics: 4 ... 20 mA Fault mode: < 3.6 mA ▼
	Current output, min./max.	Min. current: 3.8 mA Max. current: 20.5 mA
	Lock/Unlock adjustment	Released PIN: 0000
Display	Displayed value 1	Filling height
	Displayed value 2	Electronics temperature
	Backlight	Switched on

Menu	Menu item	Default value
Additional adjustments	Date/Time	Time format: 24 h
	Scaling size	Volume l
	Scaling format	100.00 lin %, 100 l 0.00 lin %, 0 l
	Current output 1 and 2 size	Lin %
	Current output 1 and 2 adjustment	100.00 %, 100 l 0.00 %, 0 l
	Linearisation	Linear
	HART mode	HART address: 0 Loop current mode: Analogue current output

**Additional settings - Copy instrument settings**

The instrument settings are copied with this function. The following functions are available:

- **Read from sensor:** Read data from sensor and store into the display and adjustment module
- **Write into sensor:** Store data from the display and adjustment module back into the sensor

The following data or settings for adjustment of the display and adjustment module are saved:

- All data of the menu "Setup" and "Display"
- The menu items "Reset, Date/Time" in the menu "Additional settings"
- The user-programmable linearization curve

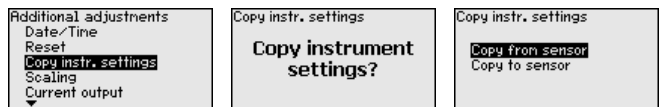

The copied data are permanently saved in an EEPROM memory in the display and adjustment module and remain there even in case of power failure. From there, they can be written into one or more sensors or kept as backup for a possible electronics exchange.



**Note:**

Before the data are saved in the sensor, a safety check is carried out to determine if the data match the sensor. In the process the sensor type of the source data as well as the target sensor are displayed. If the data do not match, a fault message is outputted or the function is blocked. The data are saved only after release.

**Additional settings - Scaling**

In the menu item "Scaling" you define the scaling variable and the scaling format for the indication of the level measured value for 0 % and 100 % on the display, for example as volume in l.

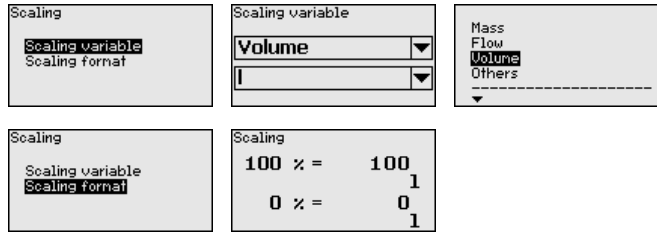

### Additional settings - Current output (size)

In menu item "*Current output, variable*" you specify which measured variable the current output refers to.

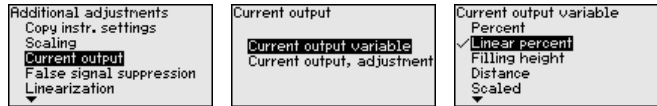

### Additional settings - Current output (adjustment)

In menu item "*Current output, adjustment*" you can assign a respective measured value to the current output.

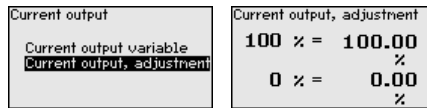

### Additional settings - False signal suppression

The following circumstances cause interfering reflections and can influence the measurement:

- High mounting sockets
- Vessel internals such as struts
- Agitators
- Buildup or welded joints on vessel walls



#### Note:

A false signal suppression detects, marks and saves these false signals to ensure that they are ignored in the level measurement.

This should be done with the lowest possible level so that all potential interfering reflections can be detected.

Proceed as follows:

1. Select with [->] the menu item "*False signal suppression*" and confirm with [OK].

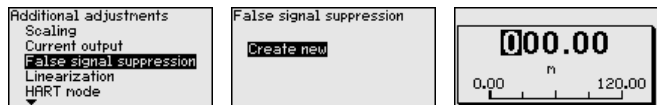

2. Confirm 3-times with [OK] and enter the actual distance from the sensor to the product surface.
3. All interfering signals in this range are detected by the sensor and stored after being confirmed with [OK].
4. All interfering signals in this range are detected by the sensor and stored after being confirmed with [OK].



**Note:**

Check the distance to the product surface, because if an incorrect (too large) value is entered, the existing level will be saved as a false signal. The level would then no longer be detectable in this area.

If a false signal suppression has already been saved in the sensor, the following menu window appears when selecting "False signal suppression":

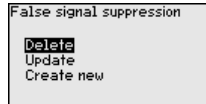

**Delete:** An already created false signal suppression will be completely deleted. This is useful if the saved false signal suppression no longer matches the metrological conditions in the vessel.

**Extend:** is used to extend an already created false signal suppression. This is useful if a false signal suppression was carried out with too high a level and not all false signals could be detected. When selecting "Extend", the distance to the product surface of the created false signal suppression is displayed. This value can now be changed and the false signal suppression can be extended to this range.

**Additional settings - Linearization**

A linearization is necessary for all vessels in which the vessel volume does not increase linearly with the level. Corresponding linearization curves are preprogrammed for these vessels. They represent the correlation between the level percentage and vessel volume. The linearization applies to the measured value indication and the current output.

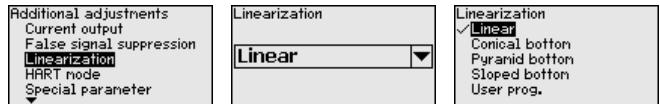

**Additional adjustments - HART mode**

In this menu item you specify the HART mode and enter the address for multidrop mode.

In the mode "Fixed current output" up to 63 sensors can be operated on one two-wire cable (Multidrop operation). An address between 0 and 63 must be assigned to each sensor.

If you select the function "Analogue current output", a 4 ... 20 mA signal is output in multidrop mode.

In the mode "Fixed current (4 mA)" a fixed 4 mA signal is output independently of the actual level.

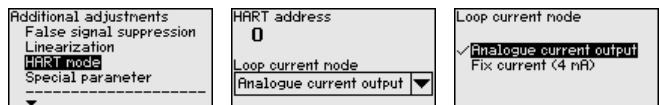

The default setting is "Analogue current output" and the address "00".

**Additional settings - Special parameters**

In this menu item you gain access to the protected area where you can enter special parameters. In exceptional cases, individual

parameters can be modified in order to adapt the sensor to special requirements.

Change the settings of the special parameters only after having contacted our service staff.

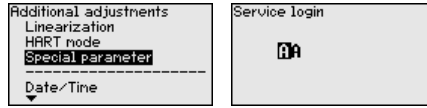

### Info

In this menu item the following information of the instrument can be read out:

- Instrument name and serial number
- Hardware and software version
- Date of the factory calibration as well as the last change via adjustment instruments
- Sensor characteristics such as approval, process fitting, seal, meas. range etc.



## 6.6 Saving the parameterisation data

### On paper

We recommend writing down the adjustment data, e.g. in this operating instructions manual, and archiving them afterwards. They are thus available for multiple use or service purposes.

### In the display and adjustment module

If the instrument is equipped with a display and adjustment module, the parameter adjustment data can be saved therein. The procedure is described in menu item "*Copy device settings*".

## 7 Setup with PACTware

### 7.1 Connect the PC

Via the interface adapter directly on the sensor

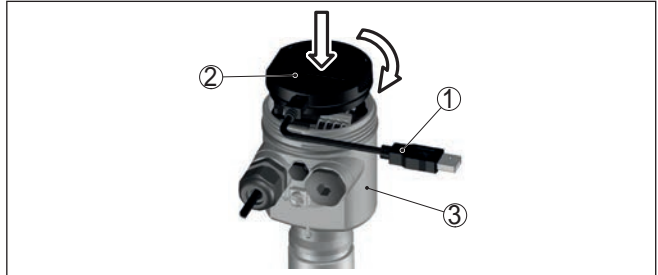

Fig. 39: Connection of the PC directly to the sensor via the interface adapter

- 1 USB cable to the PC
- 2 Interface adapter VEGACONNECT
- 3 Sensor

Via the interface adapter and HART

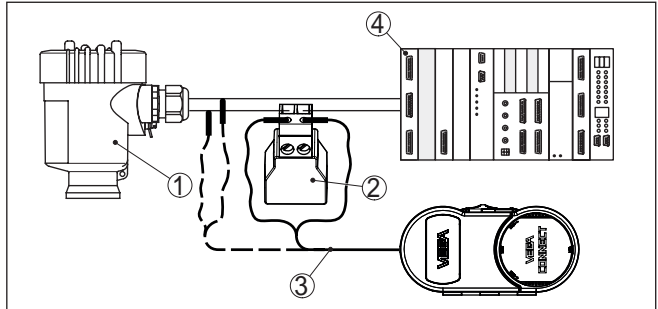

Fig. 40: Connecting the PC via HART to the signal cable

- 1 Sensor
- 2 HART resistance 250  $\Omega$  (optional depending on evaluation)
- 3 Connection cable with 2 mm pins and terminals
- 4 Processing system/PLC/Voltage supply
- 5 Interface adapter, for example VEGACONNECT 4



**Note:**

With power supply units with integrated HART resistance (internal resistance approx. 250  $\Omega$ ), an additional external resistance is not necessary. This applies, e.g. to the VEGA instruments VEGATRENN 149A, VEGAMET 381, VEGAMET 391. Common Ex separators are also usually equipped with a sufficient current limiting resistance. In such cases, the interface converter can be connected parallel to the 4 ... 20 mA cable (dashed line in the previous illustration).

### 7.2 Parameter adjustment with PACTware

For parameter adjustment of the instrument via a Windows PC, the configuration software PACTware and a suitable instrument driver

**Prerequisites**

(DTM) according to FDT standard are required. The latest PACTware version as well as all available DTMs are compiled in a DTM Collection. The DTMs can also be integrated into other frame applications according to FDT standard.



### Note:

To ensure that all instrument functions are supported, you should always use the latest DTM Collection. Furthermore, not all described functions are included in older firmware versions. You can download the latest instrument software from our homepage. A description of the update procedure is also available in the Internet.

Further setup steps are described in the operating instructions manual "DTM Collection/PACTware" attached to each DTM Collection and which can also be downloaded from the Internet. Detailed descriptions are available in the online help of PACTware and the DTMs.

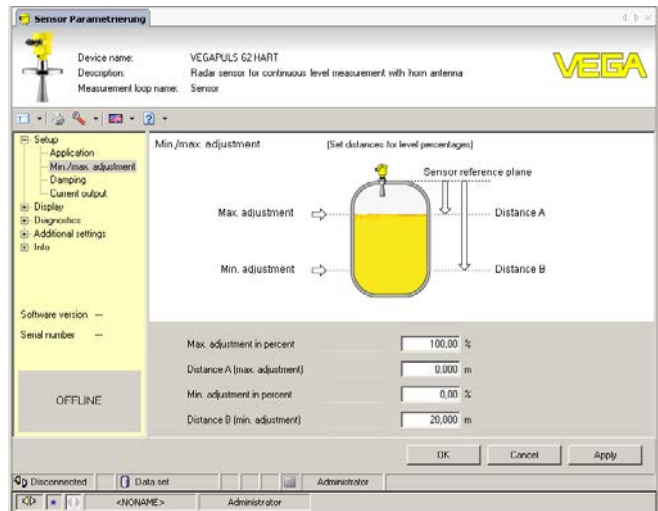

Fig. 41: Example of a DTM view

## Standard/Full version

All device DTMs are available as a free-of-charge standard version and as a full version that must be purchased. In the standard version, all functions for complete setup are already included. An assistant for simple project configuration simplifies the adjustment considerably. Saving/printing the project as well as import/export functions are also part of the standard version.

In the full version there is also an extended print function for complete project documentation as well as a save function for measured value and echo curves. In addition, there is a tank calculation program as well as a multiviewer for display and analysis of the saved measured value and echo curves.

The standard version is available as a download under [www.vega.com/downloads](http://www.vega.com/downloads) and "Software". The full version is available on CD from the agency serving you.



### 7.3 Saving the parameterisation data

We recommend documenting or saving the parameterisation data via PACTware. That way the data are available for multiple use or service purposes.

## 8 Set up with other systems

### 8.1 DD adjustment programs

Device descriptions as Enhanced Device Description (EDD) are available for DD adjustment programs such as, for example, AMS™ and PDM.

The files can be downloaded at [www.vega.com/downloads](http://www.vega.com/downloads) under "Software".

### 8.2 Field Communicator 375, 475

Device descriptions for the instrument are available as EDD for parameterisation with Field Communicator 375 or 475.

Integrating the EDD into the Field Communicator 375 or 475 requires the "Easy Upgrade Utility" software, which is available from the manufacturer. This software is updated via the Internet and new EDDs are automatically accepted into the device catalogue of this software after they are released by the manufacturer. They can then be transferred to a Field Communicator.

In the HART communication, the Universal Commands and a part of the Common Practice Commands are supported.

## 9 Diagnosis, asset management and service

### 9.1 Maintenance

#### Maintenance

If the device is used properly, no special maintenance is required in normal operation.

#### Precaution measures against buildup

In some applications, buildup on the antenna system can influence the measuring result. Depending on the sensor and application, take measures to avoid heavy soiling of the antenna system. If necessary, clean the antenna system in certain intervals.

#### Cleaning

The cleaning helps that the type label and markings on the instrument are visible.

Take note of the following:

- Use only cleaning agents which do not corrode the housings, type label and seals
- Use only cleaning methods corresponding to the housing protection rating

### 9.2 Measured value and event memory

The instrument has several memories available for diagnostic purposes. The data remain there even in case of voltage interruption.

#### Measured value memory

Up to 100,000 measured values can be stored in the sensor in a ring memory. Each entry contains date/time as well as the respective measured value. Storable values are for example:

- Distance
- Filling height
- Percentage value
- Lin. percent
- Scaled
- Current value
- Measurement reliability
- Electronics temperature

When the instrument is shipped, the measured value memory is active and stores distance, measurement reliability and electronics temperature every 3 minutes.

The requested values and recording conditions are set via a PC with PACTware/DTM or the control system with EDD. Data are thus read out and also reset.

#### Event memory

Up to 500 events are automatically stored with a time stamp in the sensor (non-deletable). Each entry contains date/time, event type, event description and value. Event types are for example:

- Modification of a parameter
- Switch-on and switch-off times
- Status messages (according to NE 107)
- Error messages (according to NE 107)

The data are read out via a PC with PACTware/DTM or the control system with EDD.

### Echo curve memory

The echo curves are stored with date and time and the corresponding echo data. The memory is divided into two sections:

**Echo curve of the setup:** This is used as reference echo curve for the measurement conditions during setup. Changes in the measurement conditions during operation or buildup on the sensor can thus be recognized. The echo curve of the setup is stored via:

- PC with PACTware/DTM
- Control system with EDD
- Display and adjustment module

**Further echo curves:** Up to 10 echo curves can be stored in a ring buffer in this memory section. Additional echo curves are stored via:

- PC with PACTware/DTM
- Control system with EDD

## 9.3 Asset Management function

The instrument features self-monitoring and diagnostics according to NE 107 and VDI/VDE 2650. In addition to the status messages in the following tables there are more detailed error messages available under the menu item "Diagnostics" via the display and adjustment module.

### Status messages

The status messages are divided into the following categories:

- Failure
- Function check
- Out of specification
- Maintenance requirement

and explained by pictographs:

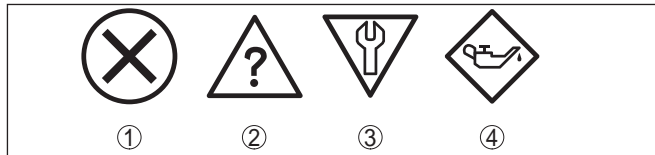

Fig. 42: Pictographs of the status messages

- 1 Failure - red
- 2 Out of specification - yellow
- 3 Function check - orange
- 4 Maintenance - blue

**Failure:** Due to a malfunction in the instrument, a fault message is output.

This status message is always active. It cannot be deactivated by the user.

**Function check:** The instrument is being worked on, the measured value is temporarily invalid (for example during simulation).

This status message is inactive by default.

**Out of specification:** The measured value is unreliable because an instrument specification was exceeded (e.g. electronics temperature).

This status message is inactive by default.

**Maintenance:** Due to external influences, the instrument function is limited. The measurement is affected, but the measured value is still valid. Plan in maintenance for the instrument because a failure is expected in the near future (e.g. due to buildup).

This status message is inactive by default.

**Failure**

Code Text message	Cause	Rectification	DevSpec State in CMD 48
F013 no measured value available	<ul style="list-style-type: none"> <li>● Sensor does not detect an echo during operation</li> <li>● Antenna system dirty or defective</li> </ul>	<ul style="list-style-type: none"> <li>● Check or correct installation and/or parameter settings</li> <li>● Clean or exchange process component or antenna</li> </ul>	Bit 0 of Byte 0 ... 5
F017 Adjustment span too small	<ul style="list-style-type: none"> <li>● Adjustment not within specification</li> </ul>	<ul style="list-style-type: none"> <li>● Change adjustment according to the limit values (difference between min. and max. ≥ 10 mm)</li> </ul>	Bit 1 of Byte 0 ... 5
F025 Error in the linearization table	<ul style="list-style-type: none"> <li>● Index markers are not continuously rising, for example illogical value pairs</li> </ul>	<ul style="list-style-type: none"> <li>● Check linearisation table</li> <li>● Delete table/Create new</li> </ul>	Bit 2 of Byte 0 ... 5
F036 No operable software	<ul style="list-style-type: none"> <li>● Failed or interrupted software update</li> </ul>	<ul style="list-style-type: none"> <li>● Repeat software update</li> <li>● Check electronics version</li> <li>● Exchanging the electronics</li> <li>● Send instrument for repair</li> </ul>	Bit 3 of Byte 0 ... 5
F040 Error in the electronics	<ul style="list-style-type: none"> <li>● Hardware defect</li> </ul>	<ul style="list-style-type: none"> <li>● Exchanging the electronics</li> <li>● Send instrument for repair</li> </ul>	Bit 4 of Byte 0 ... 5
F080 General software error	<ul style="list-style-type: none"> <li>● General software error</li> </ul>	<ul style="list-style-type: none"> <li>● Disconnect operating voltage briefly</li> </ul>	Bit 5 of Byte 0 ... 5
F105 Determine measured value	<ul style="list-style-type: none"> <li>● The instrument is still in the start phase, the measured value could not yet be determined</li> </ul>	<ul style="list-style-type: none"> <li>● Wait for the end of the switch-on phase</li> <li>● Duration up to approx. 3 minutes depending on the version and parameter settings</li> </ul>	Bit 6 of Byte 0 ... 5
F113 Communication error	<ul style="list-style-type: none"> <li>● EMC interference</li> <li>● Transmission error during external communication with 4-wire power supply unit</li> </ul>	<ul style="list-style-type: none"> <li>● Remove EMC influences</li> </ul>	Bit 12 of Byte 0 ... 5
F125 Impermissible electronics temperature	<ul style="list-style-type: none"> <li>● Temperature of the electronics in the non-specified range</li> </ul>	<ul style="list-style-type: none"> <li>● Check ambient temperature</li> <li>● Insulate electronics</li> <li>● Use instrument with higher temperature range</li> </ul>	Bit 7 of Byte 0 ... 5
F260 Error in the calibration	<ul style="list-style-type: none"> <li>● Error in the calibration carried out in the factory</li> <li>● Error in the EEPROM</li> </ul>	<ul style="list-style-type: none"> <li>● Exchanging the electronics</li> <li>● Send instrument for repair</li> </ul>	Bit 8 of Byte 0 ... 5

Code Text message	Cause	Rectification	DevSpec State in CMD 48
F261 Error in the instrument settings	<ul style="list-style-type: none"> <li>● Error during setup</li> <li>● False signal suppression faulty</li> <li>● Error when carrying out a reset</li> </ul>	<ul style="list-style-type: none"> <li>● Repeat setup</li> <li>● Carry out a reset</li> </ul>	Bit 9 of Byte 0 ... 5
F264 Installation/Setup error	<ul style="list-style-type: none"> <li>● Adjustment not within the vessel height/measuring range</li> <li>● Max. measuring range of the instrument not sufficient</li> </ul>	<ul style="list-style-type: none"> <li>● Check or correct installation and/or parameter settings</li> <li>● Use an instrument with bigger measuring range</li> </ul>	Bit 10 of Byte 0 ... 5
F265 Measurement function disturbed	<ul style="list-style-type: none"> <li>● Sensor no longer carries out a measurement</li> <li>● Operating voltage too low</li> </ul>	<ul style="list-style-type: none"> <li>● Check operating voltage</li> <li>● Carry out a reset</li> <li>● Disconnect operating voltage briefly</li> </ul>	Bit 11 of Byte 0 ... 5

### Function check

Code Text message	Cause	Rectification	DevSpec State in CMD 48
C700 Simulation active	<ul style="list-style-type: none"> <li>● A simulation is active</li> </ul>	<ul style="list-style-type: none"> <li>● Finish simulation</li> <li>● Wait for the automatic end after 60 mins.</li> </ul>	"Simulation Active" in "Standardized Status 0"

### Out of specification

Code Text message	Cause	Rectification	DevSpec State in CMD 48
S600 Impermissible electronics temperature	<ul style="list-style-type: none"> <li>● Temperature of the electronics in the non-specified range</li> </ul>	<ul style="list-style-type: none"> <li>● Check ambient temperature</li> <li>● Insulate electronics</li> <li>● Use instrument with higher temperature range</li> </ul>	Bit 5 of Byte 14 ... 24
S603 Impermissible operating voltage	<ul style="list-style-type: none"> <li>● Operating voltage below specified range</li> </ul>	<ul style="list-style-type: none"> <li>● Check electrical connection</li> <li>● If necessary, increase operating voltage</li> </ul>	Bit 11 of Byte 14 ... 24

Tab. 7: Error codes and text messages, information on causes as well as corrective measures

### Maintenance

Code Text message	Cause	Rectification	DevSpec State in CMD 48
M500 Error during the reset "delivery status"	<ul style="list-style-type: none"> <li>● The data could not be restored during the reset to delivery status</li> </ul>	<ul style="list-style-type: none"> <li>● Repeat reset</li> <li>● Load XML file with sensor data into the sensor</li> </ul>	Bit 0 of Byte 14 ... 24
M501 Error in the non-active linearisation table	<ul style="list-style-type: none"> <li>● Hardware error EEPROM</li> </ul>	<ul style="list-style-type: none"> <li>● Exchanging the electronics</li> <li>● Send instrument for repair</li> </ul>	Bit 1 of Byte 14 ... 24
M502 Error in the event memory	<ul style="list-style-type: none"> <li>● Hardware error EEPROM</li> </ul>	<ul style="list-style-type: none"> <li>● Exchanging the electronics</li> <li>● Send instrument for repair</li> </ul>	Bit 2 of Byte 14 ... 24

Code Text message	Cause	Rectification	DevSpec State in CMD 48
M503 Measurement reliability too low	<ul style="list-style-type: none"> <li>● The echo/noise ratio is too small for reliable measurement</li> <li>● Antenna dirty or defective</li> </ul>	<ul style="list-style-type: none"> <li>● Check installation and process conditions</li> <li>● Change polarisation direction</li> <li>● Use instrument with higher sensitivity</li> <li>● Clean the antenna</li> </ul>	Bit 3 of Byte 14 ... 24
M504 Error at a device interface	<ul style="list-style-type: none"> <li>● Hardware defect</li> </ul>	<ul style="list-style-type: none"> <li>● Check connections</li> <li>● Exchanging the electronics</li> <li>● Send instrument for repair</li> </ul>	Bit 4 of Byte 14 ... 24
M505 No echo available	<ul style="list-style-type: none"> <li>● Sensor does not detect an echo during operation</li> <li>● Antenna dirty or defective</li> </ul>	<ul style="list-style-type: none"> <li>● Clean the antenna</li> <li>● Use a more suitable antenna/sensor</li> <li>● Remove possible false echoes</li> <li>● Optimize sensor position and orientation</li> </ul>	Bit 5 of Byte 14 ... 24
M506 Installation/Setup error	<ul style="list-style-type: none"> <li>● Error during setup</li> </ul>	<ul style="list-style-type: none"> <li>● Check or correct installation and/or parameter settings</li> </ul>	Bit 6 of Byte 14 ... 24
M507 Error in the instrument settings	<ul style="list-style-type: none"> <li>● Error during setup</li> <li>● Error when carrying out a reset</li> <li>● False signal suppression faulty</li> </ul>	<ul style="list-style-type: none"> <li>● Carry out reset and repeat setup</li> </ul>	Bit 7 of Byte 14 ... 24

### 9.4 Rectify faults

#### Reaction when malfunction occurs

The operator of the system is responsible for taking suitable measures to rectify faults.

#### Fault rectification

The first measures are:

- Evaluation of fault messages via the adjustment device
- Checking the output signal
- Treatment of measurement errors

Further comprehensive diagnostics options are available with a PC with PACTware and the suitable DTM. In many cases, the reasons can be determined in this way and faults rectified.

#### 4 ... 20 mA signal

Connect a multimeter in the suitable measuring range according to the wiring plan. The following table describes possible errors in the current signal and helps to eliminate them:

Error	Cause	Rectification
4 ... 20 mA signal not stable	<ul style="list-style-type: none"> <li>● Fluctuating measured value</li> </ul>	<ul style="list-style-type: none"> <li>● Set damping</li> </ul>
4 ... 20 mA signal missing	<ul style="list-style-type: none"> <li>● Electrical connection faulty</li> </ul>	<ul style="list-style-type: none"> <li>● Check connection, correct, if necessary</li> </ul>
	<ul style="list-style-type: none"> <li>● Voltage supply missing</li> </ul>	<ul style="list-style-type: none"> <li>● Check cables for breaks; repair if necessary</li> </ul>
	<ul style="list-style-type: none"> <li>● Operating voltage too low, load resistance too high</li> </ul>	<ul style="list-style-type: none"> <li>● Check, adapt if necessary</li> </ul>

Error	Cause	Rectification
Current signal greater than 22 mA, less than 3.6 mA	<ul style="list-style-type: none"> <li>● Sensor electronics defective</li> </ul>	<ul style="list-style-type: none"> <li>● Exchange the instrument or send it in for repair</li> </ul>

**Treatment of measurement errors with liquids**

The below tables show typical examples of application-related measurement errors with liquids. The measurement errors are differentiated according to the following:

- Constant level
- Filling
- Emptying

The images in column "Error pattern" show the real level as a broken line and the level displayed by the sensor as a continuous line.

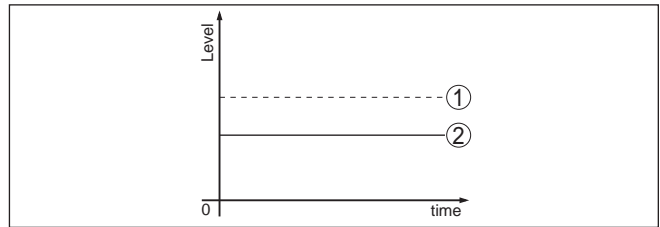

Fig. 43: Display of error images

- 1 Real level
- 2 Level displayed by the sensor

**Notes:**

- Wherever the sensor displays a constant value, the reason could also be the fault setting of the current output to "Hold value"
- If the level indication is too low, the reason could be a line resistance that is too high

**Measurement error with constant level**

Fault description	Cause	Rectification
1. Measured value shows a too low or too high level 	<ul style="list-style-type: none"> <li>● Min./max. adjustment not correct</li> </ul>	<ul style="list-style-type: none"> <li>● Adapt min./max. adjustment</li> </ul>
	<ul style="list-style-type: none"> <li>● Incorrect linearisation curve</li> </ul>	<ul style="list-style-type: none"> <li>● Adapt linearisation curve</li> </ul>
2. Measured value jumps towards 0 % 	<ul style="list-style-type: none"> <li>● Installation in a bypass tube or standpipe, hence running time error (small measurement error close to 100 %/large error close to 0 %)</li> </ul>	<ul style="list-style-type: none"> <li>● Check parameter "Application" with respect to vessel form, adapt if necessary (bypass, standpipe, diameter)</li> </ul>
	<ul style="list-style-type: none"> <li>● Multiple echo (vessel top, product surface) with amplitude higher than the level echo</li> </ul>	<ul style="list-style-type: none"> <li>● Check parameter "Application", especially vessel top, type of medium, dished bottom, high dielectric constant, and adapt if necessary</li> </ul>



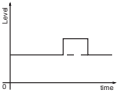

Fault description	Cause	Rectification
3. Measured value jumps towards 100 % 	<ul style="list-style-type: none"> <li>● Due to the process, the amplitude of the level echo sinks</li> <li>● A false signal suppression was not carried out</li> </ul>	<ul style="list-style-type: none"> <li>● Carry out a false signal suppression</li> </ul>
	<ul style="list-style-type: none"> <li>● Amplitude or position of a false signal has changed (e.g. condensation, buildup); false signal suppression no longer matches actual conditions</li> </ul>	<ul style="list-style-type: none"> <li>● Determine the reason for the changed false signals, carry out false signal suppression, e.g. with condensation</li> </ul>

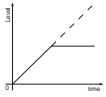
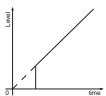
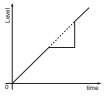
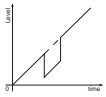
**Measurement error during filling**

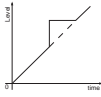
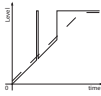
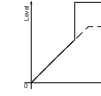
Fault description	Cause	Rectification
4. Measured value remains unchanged during filling 	<ul style="list-style-type: none"> <li>● False signals in the close range too big or level echo too small</li> <li>● Strong foam or spout generation</li> <li>● Max. adjustment not correct</li> </ul>	<ul style="list-style-type: none"> <li>● Eliminate false signals in the close range</li> <li>● Check measurement situation: Antenna must protrude out of the socket, installations</li> <li>● Remove contamination on the antenna</li> <li>● In case of interferences due to installations in the close range: Change polarisation direction</li> <li>● Create a new false signal suppression</li> <li>● Adapt max. adjustment</li> </ul>
5. Measured value remains in the bottom section during filling 	<ul style="list-style-type: none"> <li>● Echo from the tank bottom larger than the level echo, for example, with products with <math>\epsilon_r &lt; 2.5</math> oil-based, solvents</li> </ul>	<ul style="list-style-type: none"> <li>● Check parameters Medium, Vessel height and Floor form, adapt if necessary</li> </ul>
6. Measured value remains momentarily unchanged during filling and then jumps to the correct level 	<ul style="list-style-type: none"> <li>● Turbulence on the product surface, quick filling</li> </ul>	<ul style="list-style-type: none"> <li>● Check parameters, change if necessary, e.g. in dosing vessel, reactor</li> </ul>
7. Measured value jumps towards 0 % during filling 	<ul style="list-style-type: none"> <li>● Amplitude of a multiple echo (vessel top - product surface) is larger than the level echo</li> </ul>	<ul style="list-style-type: none"> <li>● Check parameter "Application", especially vessel top, type of medium, dished bottom, high dielectric constant, and adapt if necessary</li> </ul>
	<ul style="list-style-type: none"> <li>● The level echo cannot be distinguished from the false signal at a false signal position (jumps to multiple echo)</li> </ul>	<ul style="list-style-type: none"> <li>● In case of interferences due to installations in the close range: Change polarisation direction</li> <li>● Chose a more suitable installation position</li> </ul>

Fault description	Cause	Rectification
8. Measured value jumps towards 100 % during filling 	<ul style="list-style-type: none"> <li>Due to strong turbulence and foam generation during filling, the amplitude of the level echo sinks. Measured value jumps to false signal</li> </ul>	<ul style="list-style-type: none"> <li>Carry out a false signal suppression</li> </ul>
9. Measured value jumps sporadically to 100 % during filling 	<ul style="list-style-type: none"> <li>Varying condensation or contamination on the antenna</li> </ul>	<ul style="list-style-type: none"> <li>Carry out a false signal suppression or increase false signal suppression with condensation/contamination in the close range by editing</li> </ul>
10. Measured value jumps to $\geq 100\%$ or 0 m distance 	<ul style="list-style-type: none"> <li>Level echo is no longer detected at close range due to foam generation or interference signals at close range.</li> </ul>	<ul style="list-style-type: none"> <li>Check measuring point: Antenna should protrude out of the threaded mounting socket, possible false echoes through flange socket</li> <li>Remove contamination on the antenna</li> <li>Use a sensor with a more suitable antenna</li> </ul>

### Measurement error during emptying

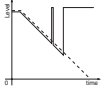
Fault description	Cause	Rectification
11. Measured value remains unchanged in the close range during emptying 	<ul style="list-style-type: none"> <li>False signal larger than the level echo</li> <li>Level echo too small</li> </ul>	<ul style="list-style-type: none"> <li>Eliminate false signal in the close range. Check: Antenna must protrude from the socket</li> <li>Remove contamination on the antenna</li> <li>In case of interferences due to installations in the close range: Change polarisation direction</li> <li>After eliminating the false signals, the false signal suppression must be deleted. Carry out a new false signal suppression</li> </ul>
12. Measured value jumps towards 0 % during emptying 	<ul style="list-style-type: none"> <li>Echo from the tank bottom larger than the level echo, for example, with products with <math>\epsilon_r &lt; 2.5</math> oil-based, solvents</li> </ul>	<ul style="list-style-type: none"> <li>Check parameters Medium type, Vessel height and Floor form, adapt if necessary</li> </ul>
13. Measured value jumps sporadically towards 100 % during emptying 	<ul style="list-style-type: none"> <li>Varying condensation or contamination on the antenna</li> </ul>	<ul style="list-style-type: none"> <li>Carry out false signal suppression or increase false signal suppression in the close range by editing</li> <li>With bulk solids, use radar sensor with purging air connection</li> </ul>

**Reaction after fault rectification**

Depending on the reason for the fault and the measures taken, the steps described in chapter "Setup" must be carried out again or must be checked for plausibility and completeness.

**24 hour service hotline**

Should these measures not be successful, please call in urgent cases the VEGA service hotline under the phone no. **+49 1805 858550**.

The hotline is also available outside normal working hours, seven days a week around the clock.

Since we offer this service worldwide, the support is provided in English. The service itself is free of charge, the only costs involved are the normal call charges.

**9.5 Exchanging the electronics module**

If the electronics module is defective, it can be replaced by the user.



In Ex applications, only instruments and electronics modules with appropriate Ex approval may be used.

If there is no electronics module available on site, the electronics module can be ordered through the agency serving you. The electronics modules are adapted to the respective sensor and differ in signal output or voltage supply.

The new electronics module must be loaded with the default settings of the sensor. These are the options:

- In the factory
- Or on site by the user

In both cases, the serial number of the sensor is needed. The serial numbers are stated on the type label of the instrument, on the inside of the housing as well as on the delivery note.

When loading on site, the order data must first be downloaded from the Internet (see operating instructions "*Electronics module*").

**Caution:**

All application-specific settings must be entered again. That's why you have to carry out a fresh setup after exchanging the electronics.

If you saved the parameter settings during the first setup of the sensor, you can transfer them to the replacement electronics module. A fresh setup is then not necessary.

**9.6 Software update**

The device software can be updated in the following ways:

- Interface adapter VEGACONNECT
- HART signal
- Bluetooth

Depending on the method, the following components are required:

- Instrument
- Voltage supply
- Interface adapter VEGACONNECT

- Display and adjustment module PLICSCOM with Bluetooth function
- PC with PACTware/DTM and Bluetooth USB adapter
- Current instrument software as file

You can find the current instrument software as well as detailed information on the procedure in the download area of our homepage: [www.vega.com](http://www.vega.com).

**Caution:**

Instruments with approvals can be bound to certain software versions. Therefore make sure that the approval is still effective after a software update is carried out.

You can find detailed information in the download area at [www.vega.com](http://www.vega.com).

## 9.7 How to proceed if a repair is necessary

You can find an instrument return form as well as detailed information about the procedure in the download area of our homepage: [www.vega.com](http://www.vega.com). By doing this you help us carry out the repair quickly and without having to call back for needed information.

In case of repair, proceed as follows:

- Print and fill out one form per instrument
- Clean the instrument and pack it damage-proof
- Attach the completed form and, if need be, also a safety data sheet outside on the packaging
- Ask the agency serving you to get the address for the return shipment. You can find the agency on our home page [www.vega.com](http://www.vega.com).

## 10 Dismount

### 10.1 Dismounting steps

**Warning:**

Before dismantling, be aware of dangerous process conditions such as e.g. pressure in the vessel or pipeline, high temperatures, corrosive or toxic products etc.

Take note of chapters "*Mounting*" and "*Connecting to voltage supply*" and carry out the listed steps in reverse order.

### 10.2 Disposal

The instrument consists of materials which can be recycled by specialised recycling companies. We use recyclable materials and have designed the electronics to be easily separable.

**WEEE directive**

The instrument does not fall in the scope of the EU WEEE directive. Article 2 of this Directive exempts electrical and electronic equipment from this requirement if it is part of another instrument that does not fall in the scope of the Directive. These include stationary industrial plants.

Pass the instrument directly on to a specialised recycling company and do not use the municipal collecting points.

If you have no way to dispose of the old instrument properly, please contact us concerning return and disposal.

## 11 Supplement

### 11.1 Technical data

#### Note for approved instruments

The technical data in the respective safety instructions are valid for approved instruments (e.g. with Ex approval). These data can differ from the data listed herein, for example regarding the process conditions or the voltage supply.

#### Materials and weights

##### Materials, wetted parts

###### Plastic horn antenna

- Adapter flange PP-GF30 black
- Seal, adapter flange FKM (COG VI500), EPDM (COG AP310)
- Focussing lense PP

###### Thread with integrated antenna

- Process fitting 316L
- Antenna PEEK
- Seal, antenna system FKM, FFKM
- Process seal Klingersil C-4400

###### Flange with encapsulated antenna system

- Flange plating, antenna encapsulation PTFE

###### Hygienic fitting with encapsulated antenna system

- Hygienic antenna encapsulation PTFE
- Surface roughness of the antenna encapsulation  $R_a < 0.8 \mu\text{m}$
- Additional process seal with certain hygienic fittings FKM-FDA, EPDM-FDA, Kalrez 6230

###### Rinsing connection

- Flushing ring PP-GFK
- O-ring seal, rinsing connection FKM (SHS FPM 70C3 GLT), EPDM (COG AP310)
- Reflux valve 316 Ti
- Sealing, reflux valve FKM (SHS FPM 70C3 GLT), EPDM (COG AP310)

##### Materials, non-wetted parts

###### Mounting parts

- Antenna cone with plastic horn antenna PBT-GF 30
- Compression flange PP-GF30 black
- Mounting strap 316L
- Fixing screws, mounting strap 316L
- Fixing screws, adapter flange 304

###### Housing

- Plastic housing Plastic PBT (Polyester)

- Aluminium die-cast housing	Aluminium die-casting AlSi10Mg, powder-coated (Basis: Polyester)
- Stainless steel housing	316L
- Cable gland	PA, stainless steel, brass
- Sealing, cable gland	NBR
- Blind plug, cable gland	PA
- Inspection window housing cover	Polycarbonate (UL-746-C listed), glass <sup>2)</sup>
- Inspection window housing cover	Polycarbonate (UL-746-C listed), glass <sup>3)</sup>
- Ground terminal	316L

**Weights**

- Instrument (depending on housing, process fitting and antenna)	approx. 2 ... 17.2 kg (4.409 ... 37.92 lbs)
--	---

---

**Torques**

---

Max. torque, thread with integrated horn antenna

- G <sup>3</sup> / <sub>4</sub>	30 Nm (22.13 lbf ft)
- G1 <sup>1</sup> / <sub>2</sub>	200 Nm (147.5 lbf ft)
- G1 <sup>1</sup> / <sub>2</sub> (with PTFE threaded adapter)	5 Nm (3.688 lbf ft)

Max. torque, plastic horn antenna

- Mounting screws, mounting strap on sensor housing	4 Nm (2.950 lbf ft)
- Flange screws, compression flange DN 80	5 Nm (3.689 lbf ft)
- Terminal screws, adapter flange - antenna	2.5 Nm (1.844 lbf ft)
- Flange screws, adapter flange DN 100	7 Nm (5.163 lbf ft)

Torque, flange with encapsulated antenna system

- Required torque of the flange screws	60 Nm (44.25 lbf ft)
- Recommended torque for tightening the flange screws	60 ... 100 Nm (44.25 ... 73.76 lbf ft)

Max. torque for NPT cable glands and Conduit tubes

- Plastic housing	10 Nm (7.376 lbf ft)
- Aluminium/Stainless steel housing	50 Nm (36.88 lbf ft)

---

**Input variable**

---

Measured variable	The measured quantity is the distance between the end of the sensor antenna and the product surface. The reference plane for the measurement and the usable measuring range are dependent on the antenna system.
-------------------	--

51141-EN-190321

<sup>2)</sup> Glass with Aluminium and stainless steel precision casting housing

<sup>3)</sup> Glass with Aluminium and stainless steel precision casting and Ex d housing

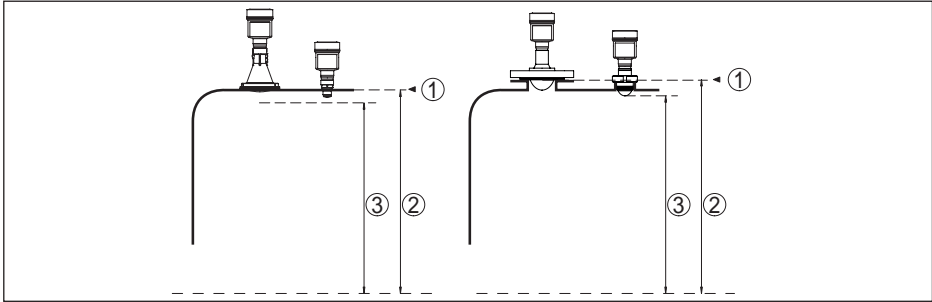

Fig. 57: Data of the input variable

- 1 Reference plane (depending on the antenna system)  
 2 Measured variable, max. measuring range  
 3 Utilisable measuring range (depending on the antenna system)

Max. measuring range	30 m (98.43 ft)
Recommended measuring range (depending on the antenna system)	
– Thread with integrated horn antenna 3/4"	up to 10 m (32.81 ft)
– Thread with integrated horn antenna 1 1/2"	up to 20 m (65.62 ft)
– Plastic horn antenna	up to 30 m (98.43 ft)
– Flange, hygienic fitting with encapsu- lated antenna system ≥DN 50, 2"	up to 25 m (82.02 ft)
– Flange, hygienic fitting with encapsu- lated antenna system ≥DN 80, 3"	up to 30 m (98.43 ft)

### Output variable

Output signal	4 ... 20 mA/HART
Range of the output signal	3.8 ... 20.5 mA/HART (default setting)
Signal resolution	0.3 µA
Resolution, digital	1 mm (0.039 in)
Fault signal, current output (adjustable)	mA-value unchanged 20.5 mA, 22 mA, < 3.6 mA
Max. output current	22 mA
Starting current	≤ 3.6 mA; ≤ 10 mA for 5 ms after switching on
Load	See load resistance under Power supply
Damping (63 % of the input variable), adjustable	0 ... 999 s
HART output values according to HART 7.0 <sup>4)</sup>	
– PV (Primary Value)	Lin. percent
– SV (Secondary Value)	Distance
– TV (Third Value)	Measurement reliability
– QV (Fourth Value)	Electronics temperature

<sup>4)</sup> Default values can be assigned individually.



Fulfilled HART specification	7.0
Further information on Manufacturer ID, Device ID, Device Revision	See website of HART Communication Foundation

**Deviation (according to DIN EN 60770-1)**

Process reference conditions according to DIN EN 61298-1

- Temperature	+18 ... +30 °C (+64 ... +86 °F)
- Relative humidity	45 ... 75 %
- Air pressure	860 ... 1060 mbar/86 ... 106 kPa (12.5 ... 15.4 psig)

Installation reference conditions

- Min. distance to internal installations	> 200 mm (7.874 in)
- Reflector	Flat plate reflector
- False reflections	Biggest false signal, 20 dB smaller than the useful signal

Deviation with liquids ≤ 1 mm (meas. distance > 0.25 m/0.8202 ft)

Non-repeatability<sup>5)</sup> ≤ 1 mm

Deviation with bulk solids The values depend to a great extent on the application. Binding specifications are thus not possible.

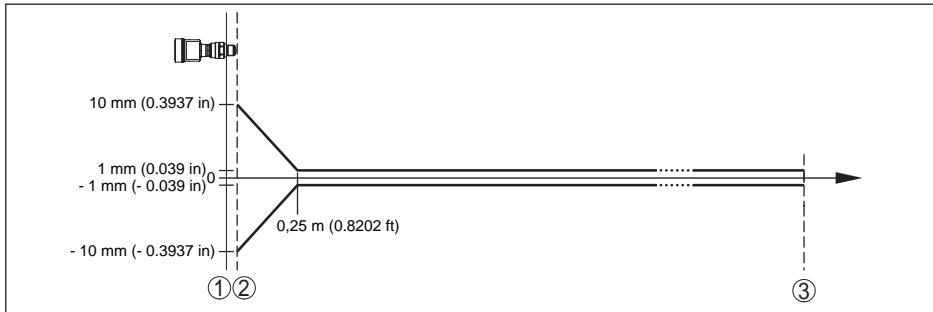

Fig. 58: Deviation under reference conditions (example: thread with integrated horn antenna, applies accordingly to all versions)

- 1 Reference plane
- 2 Antenna edge
- 3 Recommended measuring range

**Variables influencing measurement accuracy**

**Specifications apply to the digital measured value**

Temperature drift - Digital output < 3 mm/10 K, max. 10 mm

**Specifications apply also to the current output**

Temperature drift - Current output < 0.03 %/10 K or max. 0.3 % relating to the 16 mA span

Deviation in the current output due to digital/analogue conversion < 15 µA

Additional deviation through electromagnetic interference

- According to NAMUR NE 21 < 80 µA

<sup>5)</sup> Already included in the meas. deviation

- According to EN 61326-1                      None
- According to IACS E10 (shipbuilding)/ IEC 60945      < 250  $\mu$ A

---

**Characteristics and performance data**

---

Measuring frequency	W-band (80 GHz technology)
Measuring cycle time approx. <sup>6)</sup>	700 ms
Step response time <sup>7)</sup>	$\leq 3$ s
Beam angle <sup>8)</sup>	

Version	Size	Beam angle
Plastic horn antenna	DN 80	3°
Thread with integrated horn antenna	G $\frac{3}{4}$ , $\frac{3}{4}$ NPT	14°
	G1 $\frac{1}{2}$ , 1 $\frac{1}{2}$ NPT	7°
Flange with encapsulated antenna system	$\geq$ DN 50, 2"	6°
	$\geq$ DN 80, 3"	3°
Hygienic fittings	$\geq$ DN 50, 2"	6°
	$\geq$ DN 80, 3 $\frac{1}{2}$ "	3°

Emitted HF power (depending on the parameter setting<sup>9)</sup>)

- Average spectral transmission power density      -3 dBm/MHz EIRP
- Max. spectral transmission power density              +34 dBm/50 MHz EIRP
- Max. power density at a distance of 1 m              < 3  $\mu$ W/cm<sup>2</sup>

---

**Ambient conditions**

---

Ambient, storage and transport temperature      -40 ... +80 °C (-40 ... +176 °F)  
ture

---

**Process conditions**

---

For the process conditions, please also note the specifications on the type label. The lowest value (amount) always applies.

**Process temperature**

Version	Material	Seal	Process temperature (measured on the process fitting)
Plastic horn antenna, all versions			-40 ... +80 °C (-40 ... +176 °F)

<sup>6)</sup> With operating voltage  $U_b \geq 24$  V DC

<sup>7)</sup> Time span after a sudden distance change from 1 m to 5 m until the output signal reaches 90 % of the final value for the first time (IEC 61298-2). Valid with operating voltage  $U_b \geq 24$  V DC

<sup>8)</sup> Outside the specified beam angle, the energy level of the radar signal is 50% (-3 dB) less.

<sup>9)</sup> EIRP: Equivalent Isotropic Radiated Power.

Version	Material	Seal	Process temperature (measured on the process fitting)
Thread with integrated horn antenna	PEEK	FKM (SHS FPM 70C3 GLT)	-40 ... +130 °C (-40 ... +266 °F)
			-40 ... +200 °C (-40 ... +392 °F)
		FFKM (Kalrez 6230)	-15 ... +130 °C (5 ... +266 °F)
			-15 ... +200 °C (5 ... +392 °F)
		FFKM (Kalrez 6375)	-20 ... +130 °C (-4 ... +266 °F)
			-20 ... +200 °C (-4 ... +392 °F)
Flange with encapsulated antenna system	PTFE and PTFE 8 mm	PTFE	-40 ... +130 °C (-40 ... +266 °F)
			-40 ... +200 °C (-40 ... +392 °F)
			-196 ... +200 °C (-320.8 ... +392 °F) <sup>10)</sup>
	PFA	PFA	-40 ... +130 °C (-40 ... +266 °F)
			-40 ... +200 °C (-40 ... +392 °F)
Hygienic fitting with encapsulated antenna system	PTFE	PTFE	-40 ... +200 °C (-40 ... +392 °F)
		FKM (A+P 75.5/VA/75F)	-20 ... +130 °C (-4 ... +266 °F)
		EPDM (A+P 70.10-02)	-40 ... +130 °C (-40 ... +266 °F)
		FFKM (Kalrez 6230)	-15 ... +130 °C (5 ... +266 °F)

**Derating, ambient temperature**

<sup>10)</sup> Note reduced ambient temperature, see below diagram

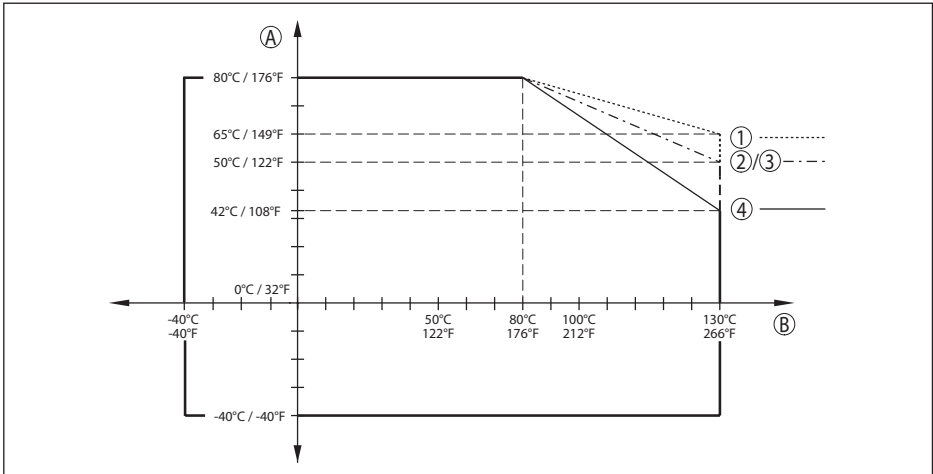

Fig. 59: Derating, ambient temperature, thread G $\frac{3}{4}$  and G1 $\frac{1}{2}$  with integrated horn antenna up to +130 °C (+266 °F)

- A Ambient temperature
- B Process temperature
- 1 Aluminium housing
- 2 Plastic housing
- 3 Stainless steel housing (precision casting)
- 4 Stainless steel housing (electropolished)

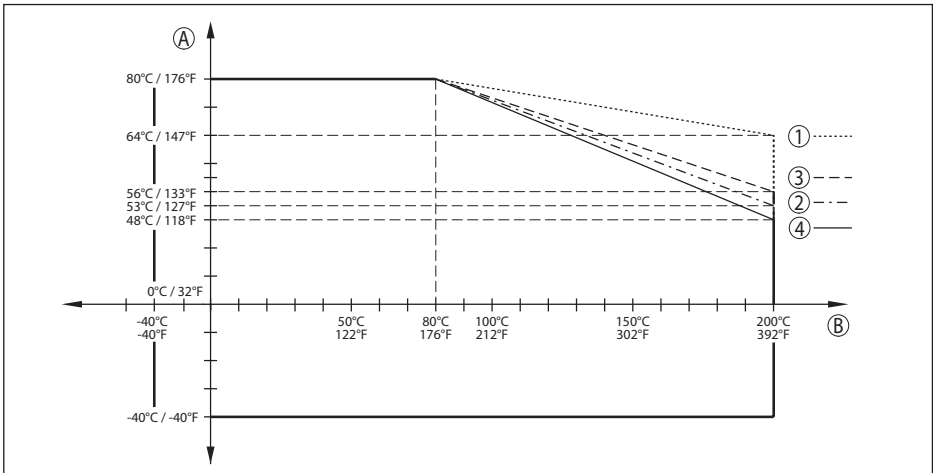

Fig. 60: Derating, ambient temperature, thread G $\frac{3}{4}$  and G1 $\frac{1}{2}$  with integrated horn antenna up to +200 °C (+392 °F)

- A Ambient temperature
- B Process temperature
- 1 Aluminium housing
- 2 Plastic housing
- 3 Stainless steel housing (precision casting)
- 4 Stainless steel housing (electropolished)

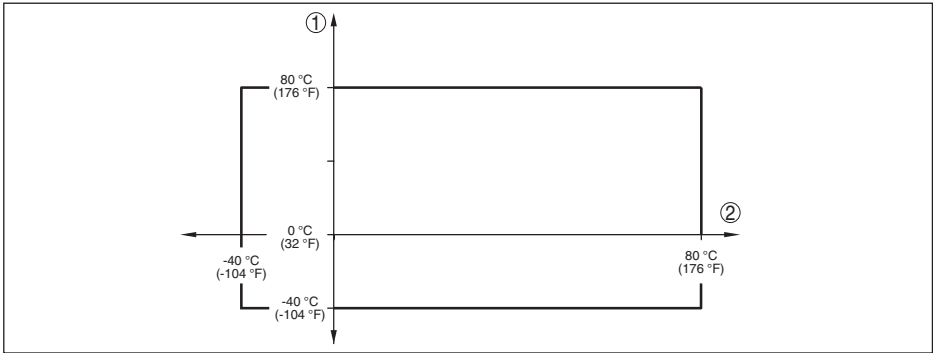

Fig. 61: Derating, ambient temperature, plastic horn antenna

- 1 Ambient temperature
- 2 Process temperature

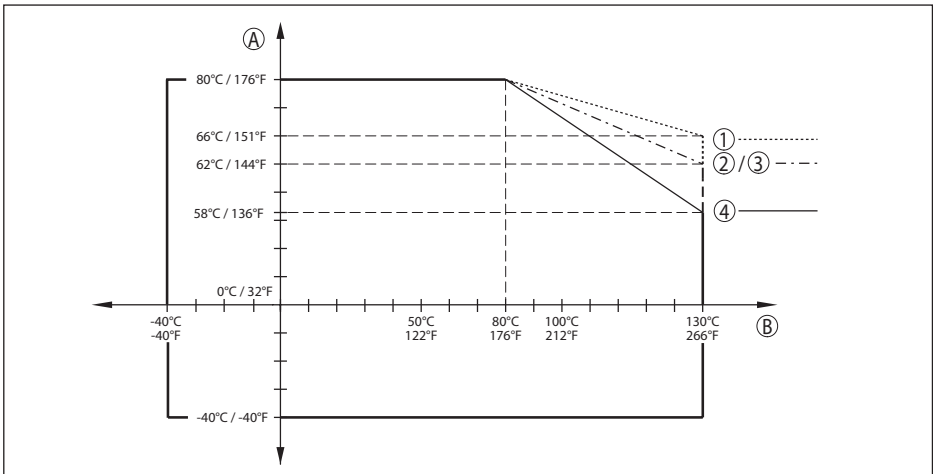

Fig. 62: Derating, ambient temperature, flange DN 50/2" and DN 80/3" with encapsulated antenna system up to +130 °C (+266 °F)

- A Ambient temperature
- B Process temperature
- 1 Aluminium housing
- 2 Plastic housing
- 3 Stainless steel housing (precision casting)
- 4 Stainless steel housing (electropolished)

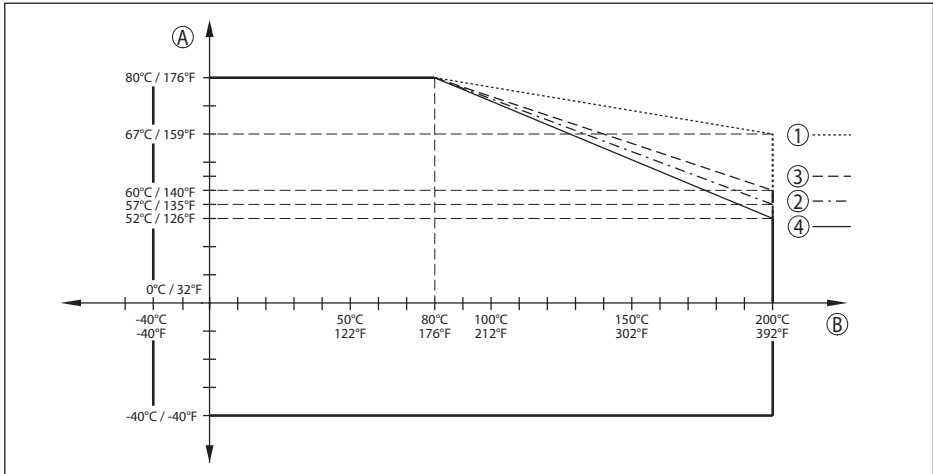

Fig. 63: Derating, ambient temperature, flange DN 50/2" and DN 80/3" with encapsulated antenna system up to +200 °C (+392 °F)

- A Ambient temperature  
 B Process temperature  
 1 Aluminium housing  
 2 Plastic housing  
 3 Stainless steel housing (precision casting)  
 4 Stainless steel housing (electropolished)

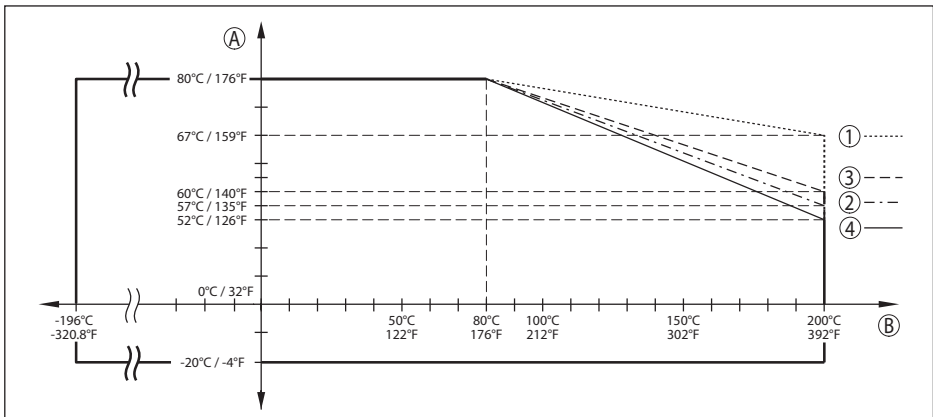

Fig. 64: Derating, ambient temperature, flange DN 50/2" and DN 80/3" with encapsulated antenna system up to -196 ... +200 °C (-320.8 ... +392 °F)

- A Ambient temperature  
 B Process temperature  
 1 Aluminium housing  
 2 Plastic housing  
 3 Stainless steel housing (precision casting)  
 4 Stainless steel housing (electropolished)

**SIP process temperature (SIP = Sterilization in place)**

Applies to instruments configurations suitable for vapour, i.e. flange or hygienic fitting with encapsulated antenna system.

Vapour stratification up to 2 h +150 °C (+302 °F)

**Process pressure**

Process fitting	Version	Process pressure
Plastic horn antenna	Compression flange	-1 ... 2 bar (-100 ... 200 kPa/-14.5 ... 29.1 psig)
	Adapter flange	-1 ... 1 bar (-100 ... 100 kPa/-14.5 ... 14.5 psig)
Thread with integrated horn antenna		-1 ... 20 bar (-100 ... 2000 kPa/-14.5 ... 290.1 psig)
Flange with encapsulated antenna system	PN 6	-1 ... 6 bar (-100 ... 600 kPa/-14.5 ... 87 psig)
	PN 16 (300 lb)	-1 ... 16 bar (-100 ... 1600 kPa/-14.5 ... 232 psig)
	PN 40 (600 lb)	
	PN 64 (900 lb)	
	PN 40 (600 lb) Version -196 ... +200 °C (-320.8 ... +392 °F)	-1 ... 25 bar (-100 ... 2500 kPa/-14.5 ... 362.6 psig)
	PN 64 (900 lb) Version -196 ... +200 °C (-320.8 ... +392 °F)	
Hygienic fitting with encapsulated antenna system	SMS	-1 ... 6 bar (-100 ... 600 kPa/-14.5 ... 87 psig)
	Varivent, Clamp 3", 3½", 4"	-1 ... 10 bar (-100 ... 1000 kPa/-14.5 ... 145 psig)
	Remaining hygienic fittings	-1 ... 16 bar (-100 ... 1600 kPa/-14.5 ... 232 psig)

Vessel pressure relating to the flange nominal pressure stage see supplementary instructions manual "*Flanges according to DIN-EN-ASME-JIS*"

**Mechanical stress**

Vibration resistance - Plastic horn antenna

- With adapter flange 2 g at 5 ... 200 Hz according to EN 60068-2-6 (vibration with resonance)
- with mounting strap 1 g at 5 ... 200 Hz according to EN 60068-2-6 (vibration with resonance)

Vibration resistance - Thread with integrated horn antenna, flange with encapsulated antenna system 4 g at 5 ... 200 Hz according to EN 60068-2-6 (vibration with resonance)

Shock resistance 100 g, 6 ms according to EN 60068-2-27 (mechanical shock)

**Data on rinsing air connection**

Max. permissible pressure 6 bar (87.02 psig)

Air volume, depending on pressure (recommended range)

Plastic horn antenna	Air volume	
	Without reflux valve	With reflux valve
Pressure		
0.2 bar (2.9 psig)	3.3 m³/h	-

51141-EN-190321

Plastic horn antenna	Air volume	
	Without reflux valve	With reflux valve
Pressure		
0.4 bar (5.8 psig)	5 m <sup>3</sup> /h	-
0.6 bar (8.7 psig)	6 m <sup>3</sup> /h	1 m <sup>3</sup> /h
0.8 bar (11.6 psig)	-	2.1 m <sup>3</sup> /h
1 bar (14.5 psig)	-	3 m <sup>3</sup> /h
1.2 bar (17.4 psig)	-	3.5 m <sup>3</sup> /h
1.4 bar (20.3 psig)	-	4.2 m <sup>3</sup> /h
1.6 bar (23.2 psig)	-	4.4 m <sup>3</sup> /h
1.8 bar (20.3 psig)	-	4.8 m <sup>3</sup> /h
2 bar (23.2 psig)	-	5.1 m <sup>3</sup> /h

## Connection

- Thread G $\frac{1}{8}$

## Reflux valve - (optional, is absolutely necessary for Ex applications)

- Material 316Ti
- Thread G $\frac{1}{8}$
- Seal FKM (SHS FPM 70C3 GLT), EPDM (COG AP310)
- For connection G $\frac{1}{8}$
- Opening pressure 0.5 bar (7.25 psig)
- Nominal pressure stage PN 250

**Electromechanical data - version IP 66/IP 67 and IP 66/IP 68; (0.2 bar)**

## Options of the cable entry

- Cable entry M20 x 1.5;  $\frac{1}{2}$  NPT
- Cable gland M20 x 1.5;  $\frac{1}{2}$  NPT (cable  $\varnothing$  see below table)
- Blind plug M20 x 1.5;  $\frac{1}{2}$  NPT
- Closing cap  $\frac{1}{2}$  NPT

Material cable gland	Material seal insert	Cable diameter				
		4.5 ... 8.5 mm	5 ... 9 mm	6 ... 12 mm	7 ... 12 mm	10 ... 14 mm
PA	NBR	-	●	●	-	●
Brass, nickel-plated	NBR	●	●	●	-	-
Stainless steel	NBR	-	●	●	-	●

## Wire cross-section (spring-loaded terminals)

- Massive wire, stranded wire 0.2 ... 2.5 mm<sup>2</sup> (AWG 24 ... 14)
- Stranded wire with end sleeve 0.2 ... 1.5 mm<sup>2</sup> (AWG 24 ... 16)



## Electromechanical data - version IP 66/IP 68 (1 bar)

### Options of the cable entry

- Cable gland with integrated connection cable M20 x 1.5 (cable:  $\varnothing$  5 ... 9 mm)
- Cable entry ½ NPT
- Blind plug M20 x 1.5; ½ NPT

### Connection cable

- Wire cross-section 0.5 mm<sup>2</sup> (AWG 20)
- Wire resistance < 0.036  $\Omega$ /m
- Tensile strength < 1200 N (270 lbf)
- Standard length 5 m (16.4 ft)
- Max. length 180 m (590.6 ft)
- Min. bending radius 25 mm (0.984 in) with 25 °C (77 °F)
- Diameter approx. 8 mm (0.315 in)
- Colour - Non-Ex version Black
- Colour - Ex-version Blue

## Display and adjustment module

Display element Display with backlight

### Measured value indication

- Number of digits 5

### Adjustment elements

- 4 keys **[OK], [->], [+], [ESC]**
- Switch Bluetooth On/Off

### Bluetooth interface

- Standard Bluetooth smart
- Effective range 25 m (82.02 ft)

### Protection rating

- unassembled IP 20
- Mounted in the housing without lid IP 40

### Materials

- Housing ABS
- Inspection window Polyester foil

Functional safety SIL non-reactive

## Interface to the external display and adjustment unit

Data transmission Digital (I<sup>2</sup>C-Bus)

Connection cable Four-wire

Sensor version	Configuration, connection cable	
	Max. cable length	Screened
4 ... 20 mA/HART	50 m	●

**Integrated clock**

Date format	Day.Month.Year
Time format	12 h/24 h
Time zone, factory setting	CET
Max. rate deviation	10.5 min/year

**Additional output parameter - Electronics temperature**

Range	-40 ... +85 °C (-40 ... +185 °F)
Resolution	< 0.1 K
Deviation	±3 K
Output of the temperature values	
– Indication	Via the display and adjustment module
– Analogue	Via the current output, the additional current output
– Digital	Via the digital output signal (depending on the electronics version)

**Voltage supply**

Operating voltage $U_B$	12 ... 35 V DC
Operating voltage $U_B$ with lighting switched on	18 ... 35 V DC
Reverse voltage protection	Integrated
Permissible residual ripple	
– for $12\text{ V} < U_B < 18\text{ V}$	$\leq 0.7 V_{\text{eff}}$ (16 ... 400 Hz)
– for $18\text{ V} < U_B < 35\text{ V}$	$\leq 1 V_{\text{eff}}$ (16 ... 400 Hz)
Load resistor	
– Calculation	$(U_B - U_{\text{min}})/0.022\text{ A}$
– Example - $U_B = 24\text{ V DC}$	$(24\text{ V} - 12\text{ V})/0.022\text{ A} = 545\ \Omega$

**Potential connections and electrical separating measures in the instrument**

Electronics	Not non-floating
Reference voltage <sup>11)</sup>	500 V AC
Conductive connection	Between ground terminal and metallic process fitting

**Electrical protective measures**

Housing material	Version	Protection acc. to IEC 60529	Protection acc. to NEMA
Plastic	Single chamber	IP 66/IP 67	Type 4X
	Double chamber	IP 66/IP 67	Type 4X
Aluminium	Single chamber	IP 66/IP 68 (0.2 bar) IP 68 (1 bar)	Type 6P -
	Double chamber	IP 66/IP 68 (0.2 bar) IP 68 (1 bar)	Type 6P -

<sup>11)</sup> Galvanic separation between electronics and metal housing parts

Housing material	Version	Protection acc. to IEC 60529	Protection acc. to NEMA
Stainless steel (electro-polished)	Single chamber	IP 66/IP 68 (0.2 bar)	Type 6P
		IP 69K (0.2 bar)	Type 6P
Stainless steel (precision casting)	Single chamber	IP 66/IP 68 (0.2 bar) IP 68 (1 bar)	Type 6P -
	Double chamber	IP 66/IP 68 (0.2 bar) IP 68 (1 bar)	Type 6P -

Connection of the feeding power supply unit Networks of overvoltage category III

Altitude above sea level

- by default up to 2000 m (6562 ft)
- with connected overvoltage protection up to 5000 m (16404 ft)

Pollution degree (with fulfilled housing protection) 4

Protection rating (IEC 61010-1) III

### Approvals

Instruments with approvals can have different technical specifications depending on the version.

For that reason the associated approval documents of these instruments have to be carefully noted. They are part of the delivery or can be downloaded by entering the serial number of your instrument into the search field under [www.vega.com](http://www.vega.com) as well as in the general download area.

## 11.2 Radio astronomy stations

Certain restrictions on the use of VEGAPULS 64 outside closed vessels result from the radio license. You can find these restrictions in chapter "Radio license for Europe". Some of these restrictions have to do radio astronomy stations. The following table states the geographic positions of radio astronomy stations in Europe:

Country	Name of the Station	Geographic Latitude	Geographic Longitude
Finland	Metsähovi	60°13'04" N	24°23'37" E
France	Plateau de Bure	44°38'01" N	05°54'26" E
Germany	Effelsberg	50°31'32" N	06°53'00" E
Italy	Sardinia	39°29'50" N	09°14'40" E
Spain	Yebes	40°31'27" N	03°05'22" W
	Pico Veleta	37°03'58" N	03°23'34" W
Sweden	Onsala	57°23'45" N	11°55'35" E

## 11.3 Dimensions

The following dimensional drawings represent only an extract of all possible versions. Detailed dimensional drawings can be downloaded at [www.vega.com/downloads](http://www.vega.com/downloads) under "Drawings".

### Plastic housing

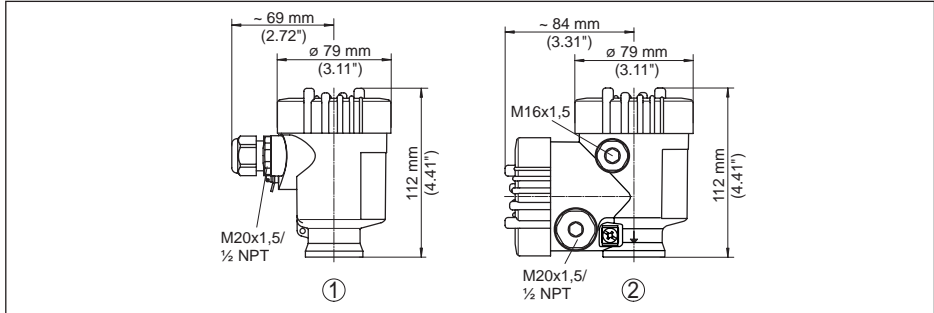

Fig. 65: Housing versions in protection IP 66/IP 67 (with integrated display and adjustment module the housing is 9 mm/0.35 in higher)

- 1 Plastic single chamber
- 2 Plastic double chamber

### Aluminium housing

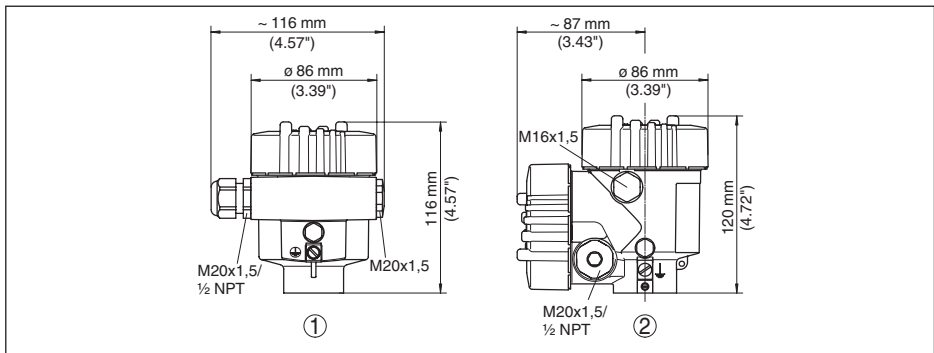

Fig. 66: Housing versions with protection rating IP 66/IP 68 (0.2 bar), (with integrated display and adjustment module the housing is 18 mm/0.71 in higher)

- 1 Aluminium - single chamber
- 2 Aluminium - double chamber

**Aluminium housing with protection rating IP 66/IP 68, 1 bar**

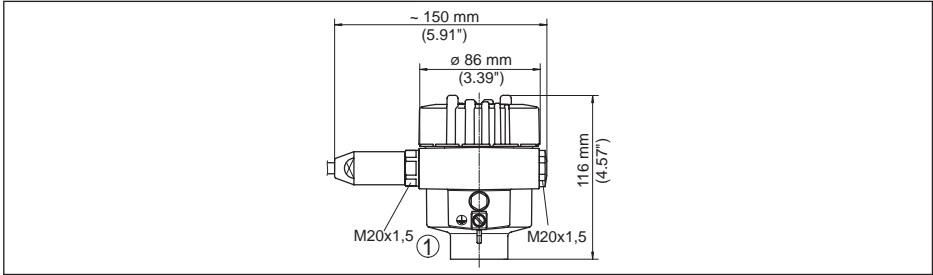

Fig. 67: Housing version with protection rating IP 66/IP 68 (1 bar), (with integrated display and adjustment module the housing is 18 mm/0.71 in higher)

1 Aluminium - single chamber

**Stainless steel housing**

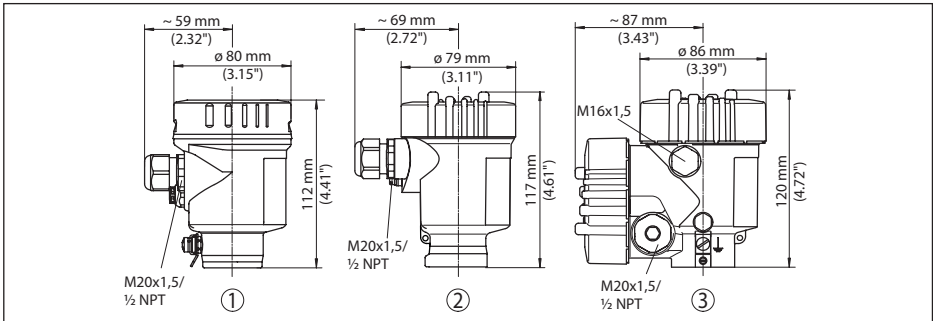

Fig. 68: Housing versions with protection rating IP 66/IP 68 (0.2 bar), (with integrated display and adjustment module the housing is 18 mm/0.71 in higher)

- 1 Stainless steel single chamber (electropolished)
- 2 Stainless steel single chamber (precision casting)
- 3 Stainless steel double chamber housing (precision casting)

### Stainless steel housing with protection rating IP 66/IP 68, 1 bar

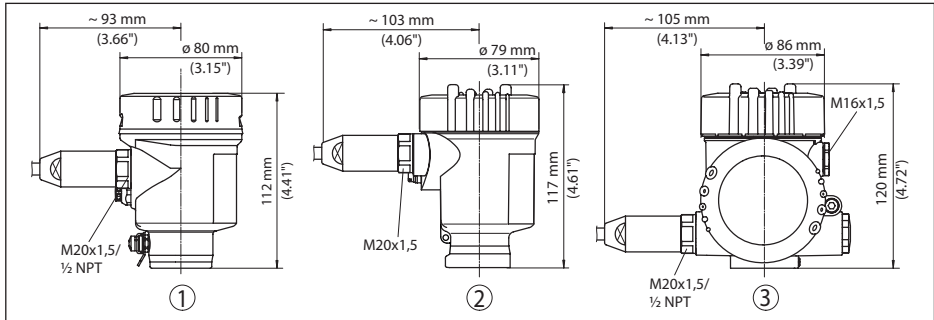

Fig. 69: Housing version with protection rating IP 66/IP 68 (1 bar), (with integrated display and adjustment module the housing is 18 mm/0.71 in higher)

1 Stainless steel single chamber (precision casting)

### VEGAPULS 64, plastic horn antenna with compression flange

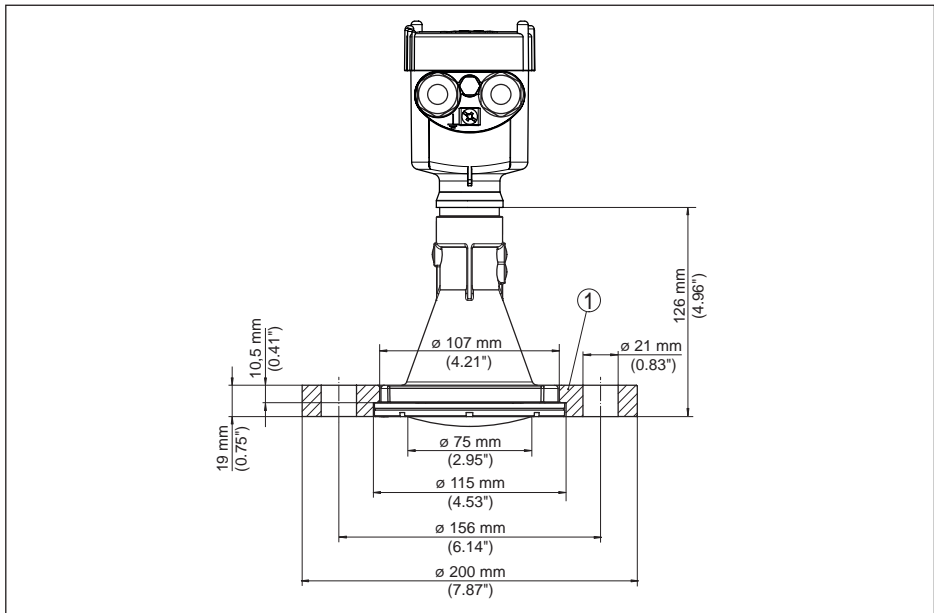

Fig. 70: Radar sensor with compression flange suitable for 3" 150 lbs, DN 80 PN 16

1 Compression flange

**VEGAPULS 64, plastic horn antenna with compression flange and rinsing connection**

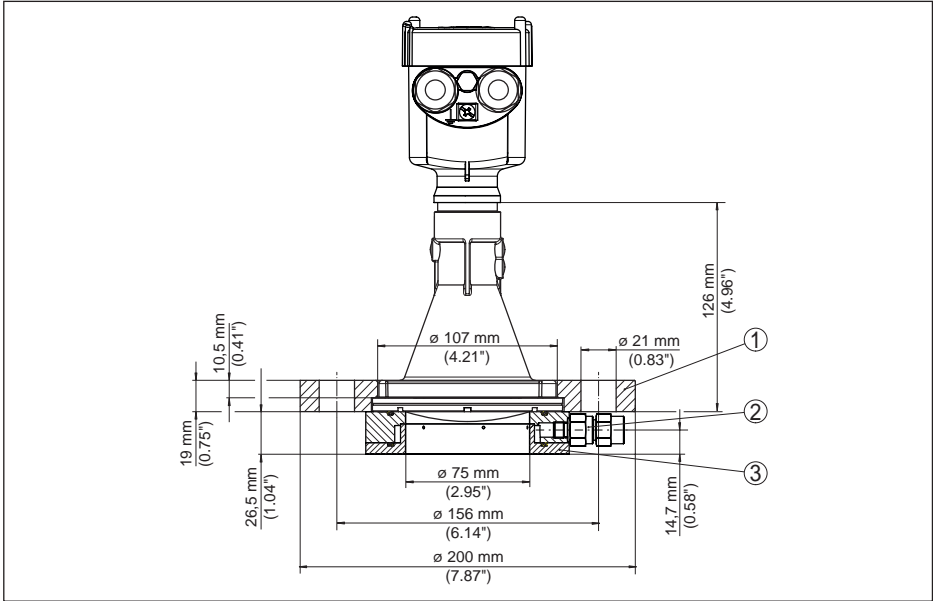

Fig. 71: Radar sensor with compression flange and rinsing connection suitable for 3" 150 lbs, DN 80 PN 16

- 1 Compression flange
- 2 Reflux valve
- 3 Rinsing connection

**VEGAPULS 64, plastic horn antenna with adapter flange**

Fig. 72: Radar sensor with adapter flange DN 100 PN 6

- 1 Adapter flange
- 2 Process seal



**VEGAPULS 64, plastic horn antenna mit adapter flange und rinsing connection**

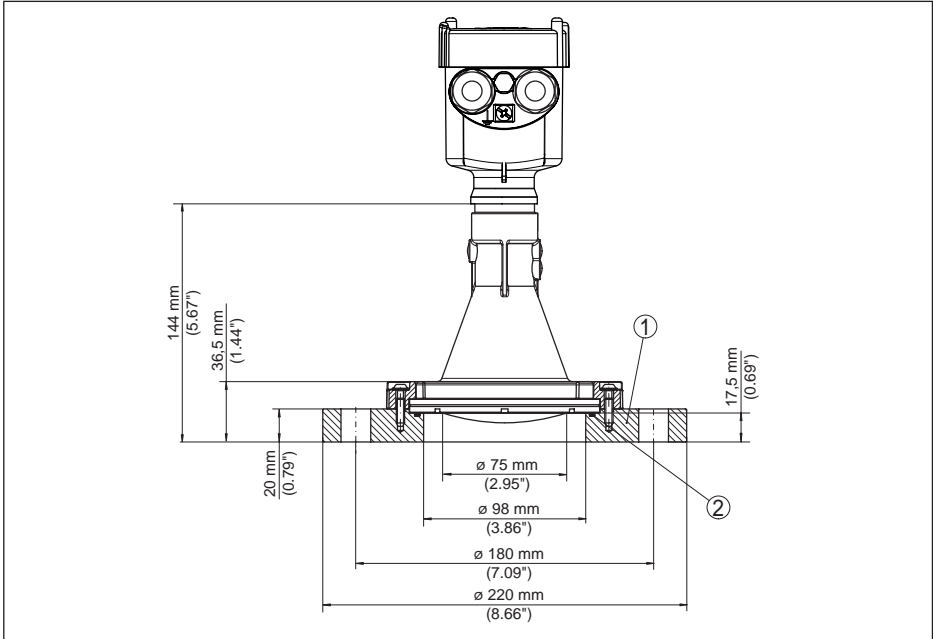
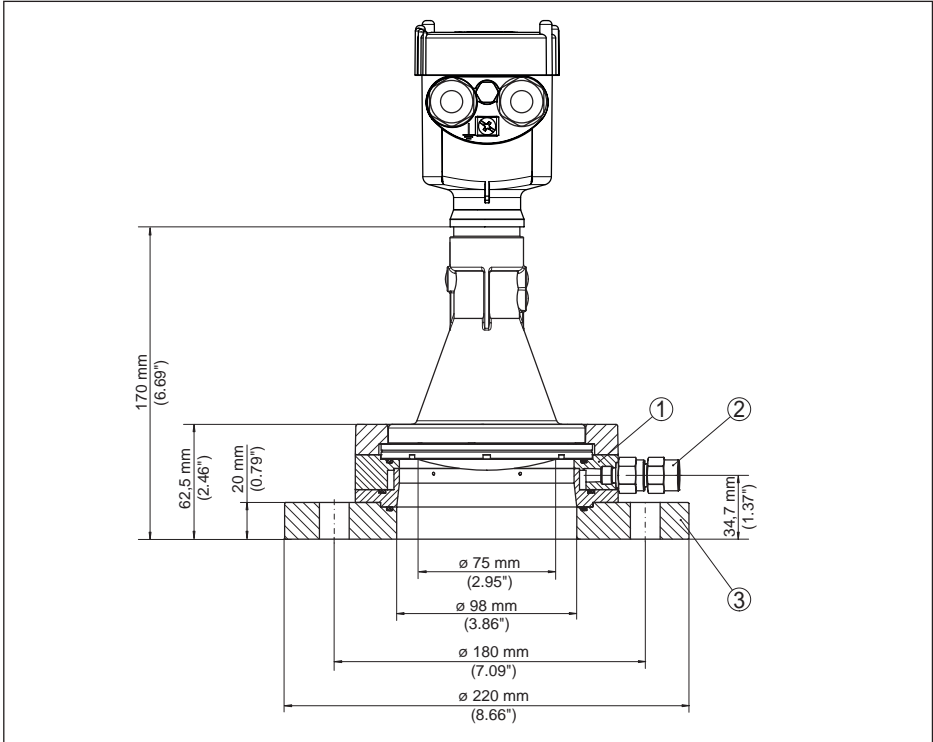

Fig. 73: VEGAPULS 64, adapter flange and rinsing connection DN 100 PN 6

- 1 Rinsing air connection
- 2 Reflux valve
- 3 Adapter flange

**VEGAPULS 64, plastic horn antenna with mounting strap**

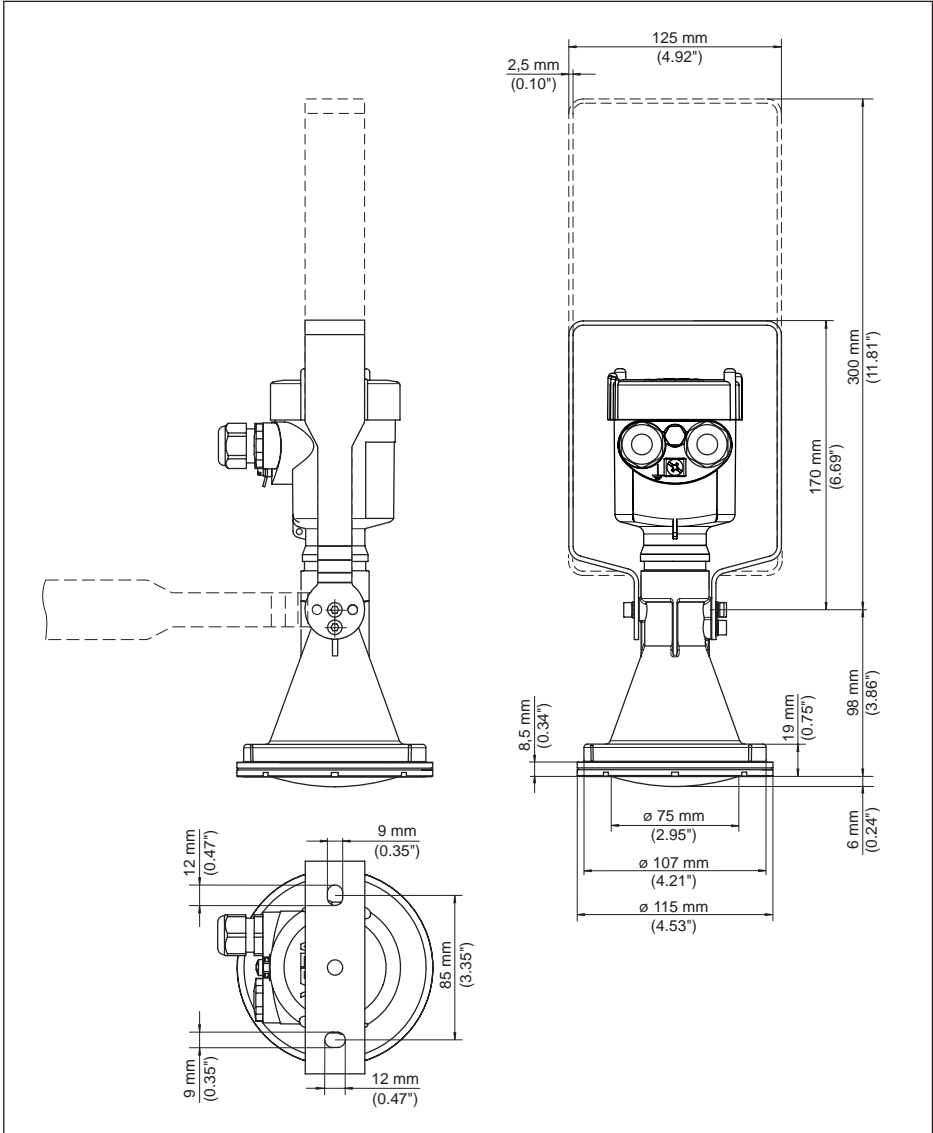

Fig. 74: VEGAPULS 64, plastic horn antenna, mounting strap in 170 or 300 mm length

**VEGAPULS 64, thread with integrated horn antenna**

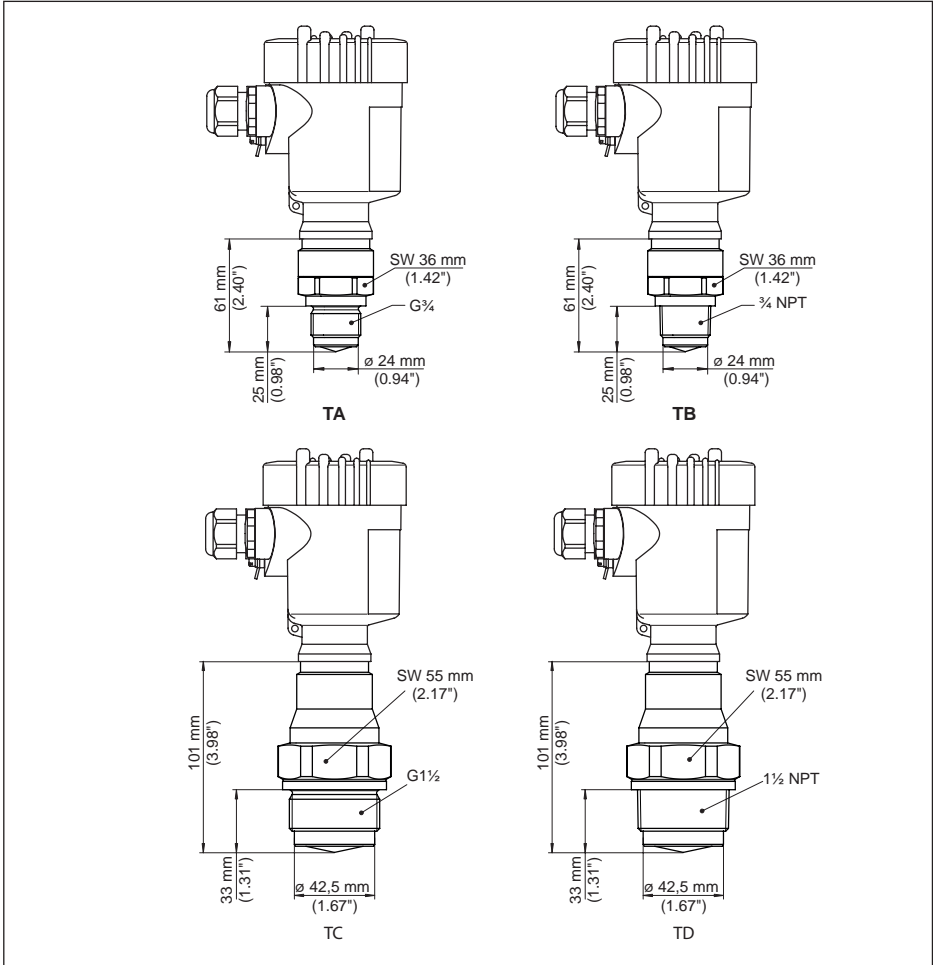

Fig. 75: VEGAPULS 64, thread with integrated horn antenna

TA G $\frac{3}{4}$  (DIN 3852-E)

TB  $\frac{1}{4}$  NPT (ASME B1.20.1)

TC G1 $\frac{1}{2}$  (DIN 3852-A)

TD 1 $\frac{1}{2}$  NPT (ASME B1.20.1)

### VEGAPULS 64, flange with encapsulated antenna system

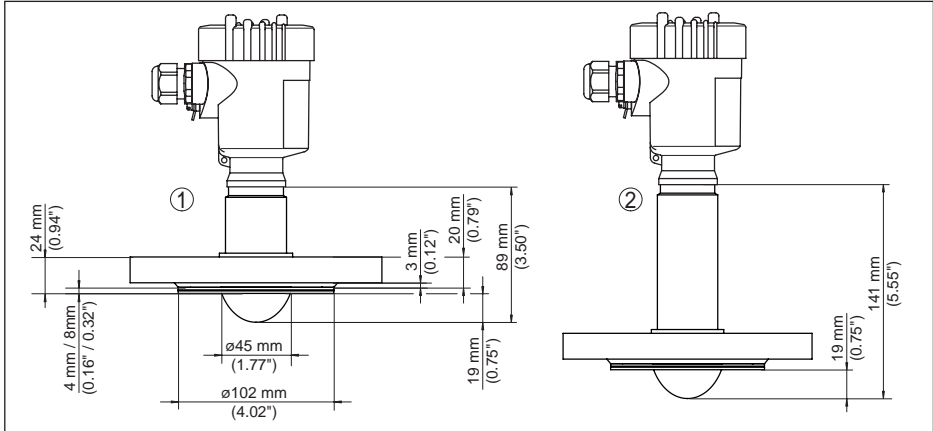

Fig. 76: VEGAPULS 64, encapsulated antenna system DN 50 PN 40

- 1 Version up to 130 °C (266 °F)
- 2 Version up to 200 °C (392 °F)

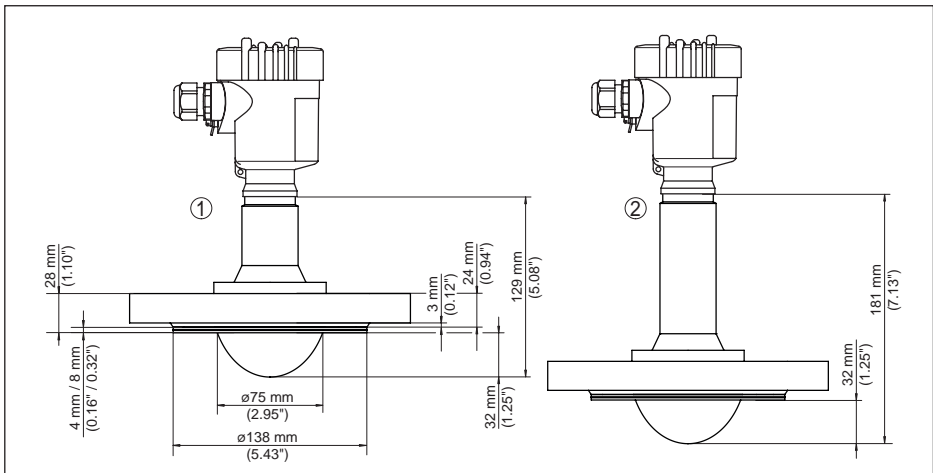

Fig. 77: VEGAPULS 64, encapsulated antenna system DN 80 PN 40

- 1 Version up to 130 °C (266 °F)
- 2 Version up to 200 °C (392 °F)

VEGAPULS 64, hygienic fitting with encapsulated antenna system 1

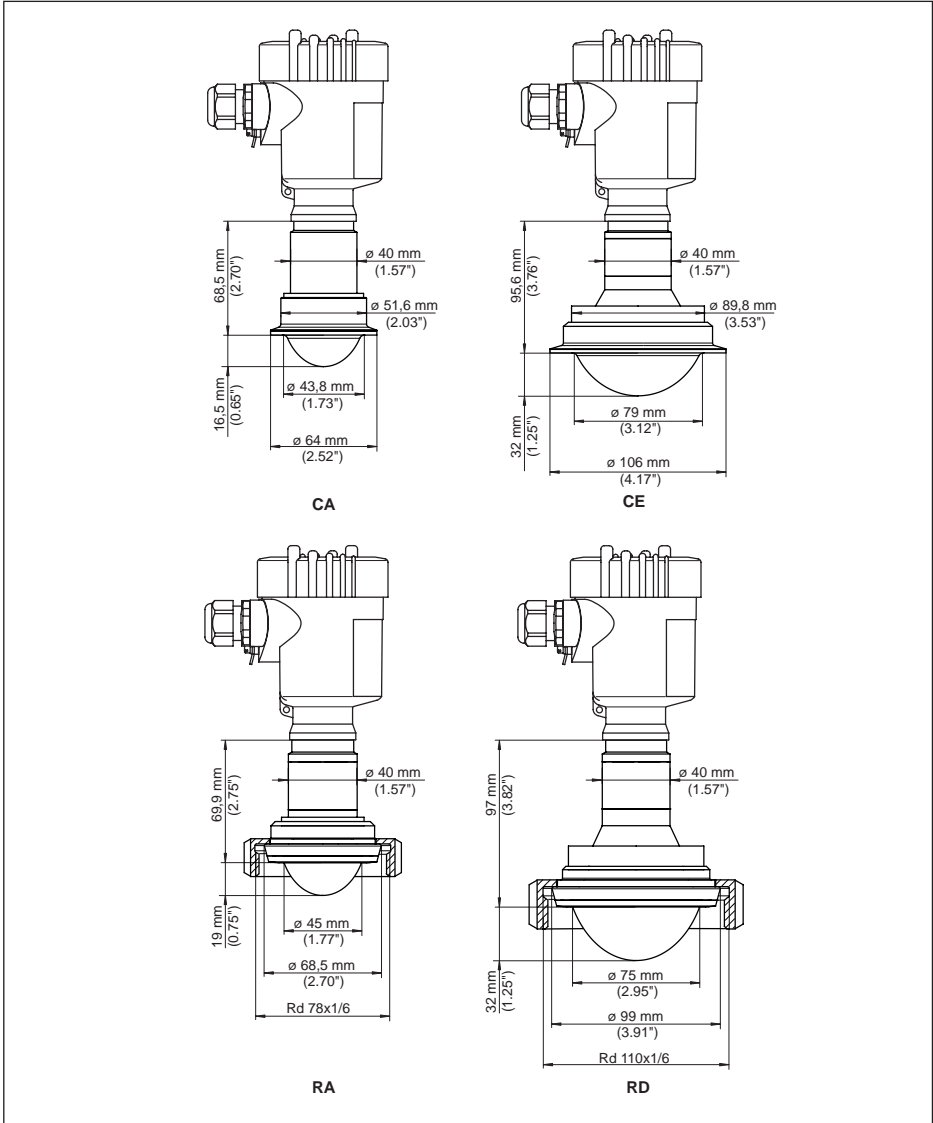

Fig. 78: VEGAPULS 64, hygienic fitting with encapsulated antenna system

- CA Clamp 2" PN 16 (DIN 32676, ISO 2852)
- CE Clamp 3½" PN 16 (DIN 32676, ISO 2852)
- RA Slotted nut DN 50 PN 16 (DIN 11851)
- RD Slotted nut DN 100 PN 16 (DIN 11851)

51141-EN-190321

**VEGAPULS 64, hygienic fitting with encapsulated antenna system 2**

Fig. 79: VEGAPULS 64, hygienic fitting with encapsulated antenna system

SA SMS DN 51

Q1 DRD

VA Varivent Form F DN 25

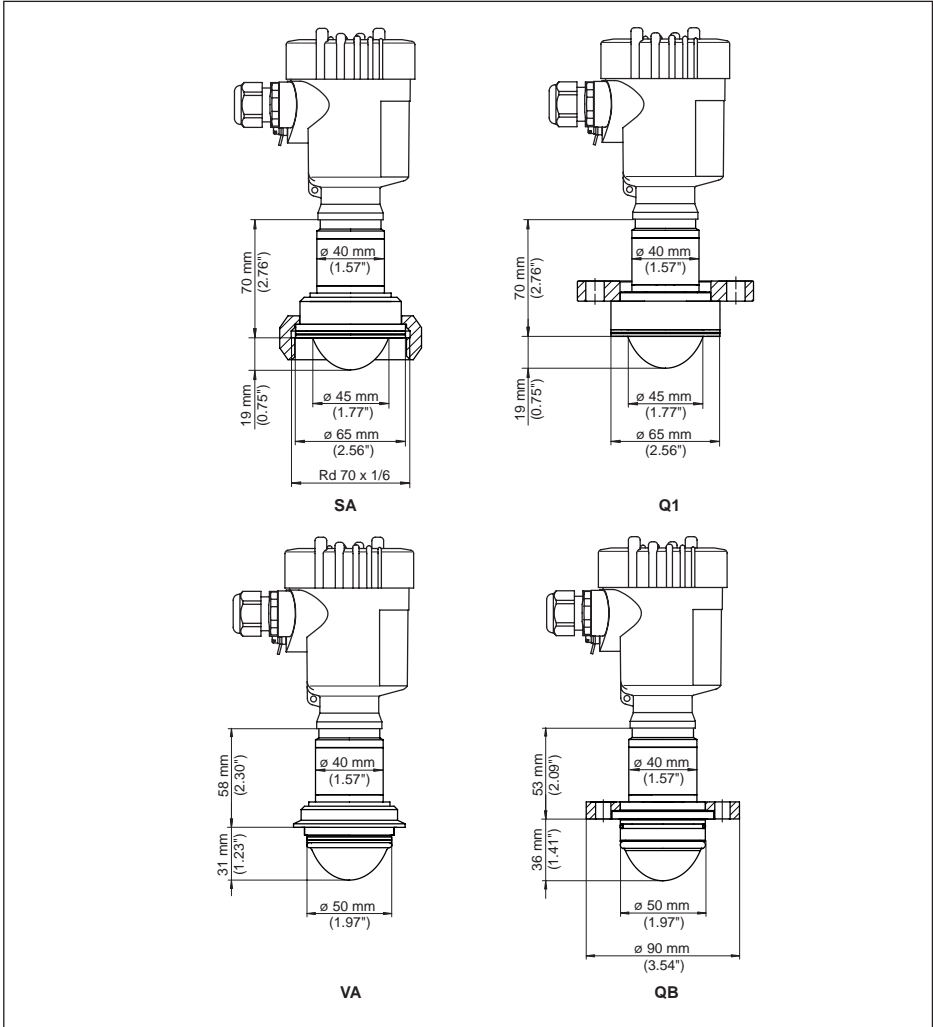
QB NeumoBiocontrol

VEGAPULS 64, hygienic fitting with encapsulated antenna system 3

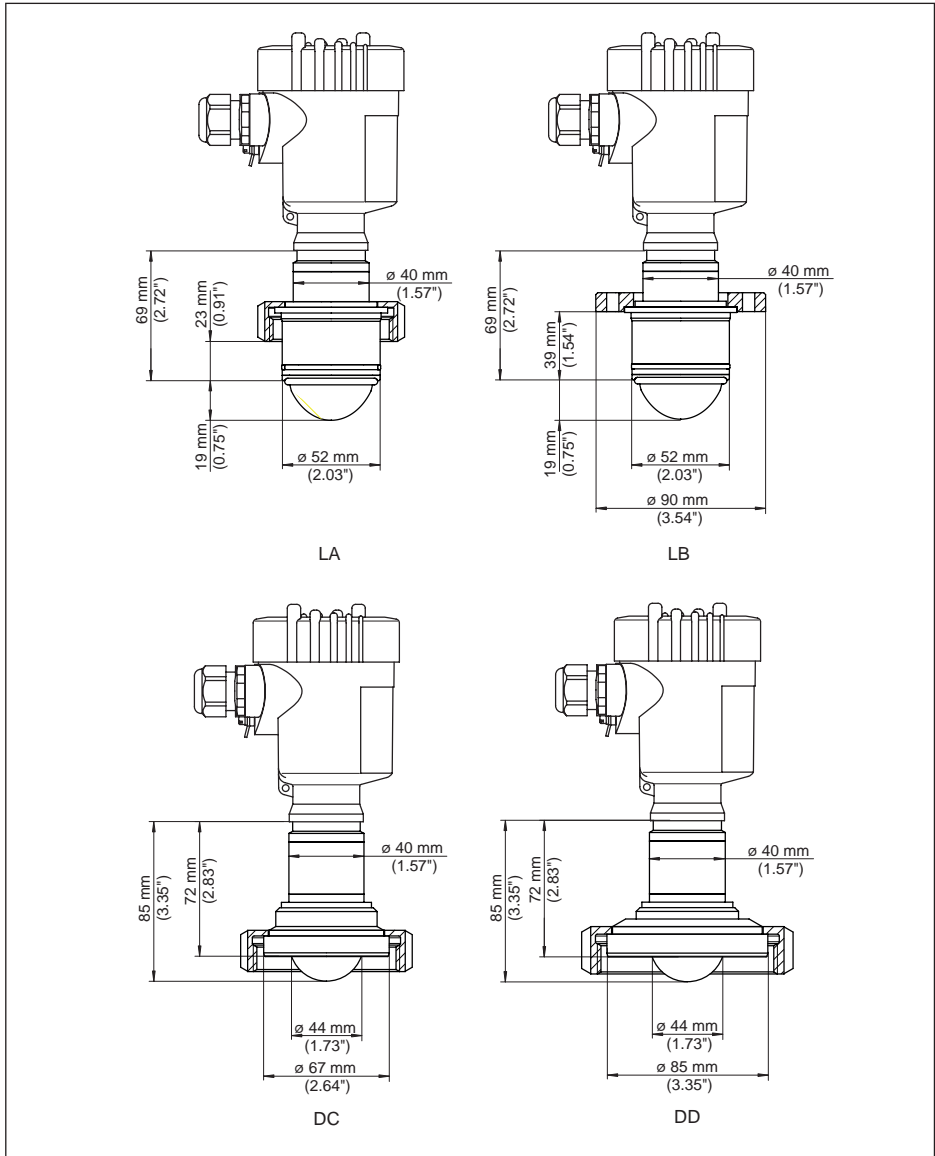

Fig. 80: VEGAPULS 64, hygienic fitting with encapsulated antenna system

LA Hygienic connection with compression nut F 40 PN 16

LB Hygienic fitting with tension flange DN 32 PN 16

DC Collar socket DN 50 Form A (DIN 11864-1)

DD Collar socket DN 65 Form A (DIN 11864-1)

## 11.4 Industrial property rights

VEGA product lines are global protected by industrial property rights. Further information see [www.vega.com](http://www.vega.com).

VEGA Produktfamilien sind weltweit geschützt durch gewerbliche Schutzrechte.

Nähere Informationen unter [www.vega.com](http://www.vega.com).

Les lignes de produits VEGA sont globalement protégées par des droits de propriété intellectuelle. Pour plus d'informations, on pourra se référer au site [www.vega.com](http://www.vega.com).

VEGA líneas de productos están protegidas por los derechos en el campo de la propiedad industrial. Para mayor información revise la pagina web [www.vega.com](http://www.vega.com).

Линии продукции фирмы ВЕГА защищаются по всему миру правами на интеллектуальную собственность. Дальнейшую информацию смотрите на сайте [www.vega.com](http://www.vega.com).

VEGA系列产品在全球享有知识产权保护。

进一步信息请参见网站[www.vega.com](http://www.vega.com)。

## 11.5 Trademark

All the brands as well as trade and company names used are property of their lawful proprietor/originator.



A large grid of graph paper for taking notes, consisting of 20 columns and 30 rows of small squares.





Printing date:

# VEGA

All statements concerning scope of delivery, application, practical use and operating conditions of the sensors and processing systems correspond to the information available at the time of printing.

Subject to change without prior notice

© VEGA Grieshaber KG, Schiltach/Germany 2019



51141-EN-190321

VEGA Grieshaber KG  
Am Hohenstein 113  
77761 Schiltach  
Germany

Phone +49 7836 50-0  
Fax +49 7836 50-201  
E-mail: [info.de@vega.com](mailto:info.de@vega.com)  
[www.vega.com](http://www.vega.com)