

# THERMOCOUPLE DIN RAIL TRANSMITTER

## SEM1605/TC

- > COST EFFECTIVE THERMOCOUPLE TRANSMITTER
- > THERMOCOUPLE TYPES K J E N T R S L U B C G
- > (4 to 20) mA TWO WIRE OUTPUT
- > SIMPLE CONFIGURATION VIA USB PORT
- > CALIBRATE AGAINST LIVE INPUT FUNCTION



## > INTRODUCTION

The SEM1605TC is a DIN rail mounted temperature transmitter from Status Instruments. It has been designed to accept most common thermocouple sensor inputs and provide the user with a standard two wire (4 to 20) mA output signal. Galvanic isolation is provided between input and output and all temperature ranges are linear to temperature.

Designed for ease of use, our latest USB interface is fitted for quick and easy configuration. Just connect a standard USB cable between the SEM1605TC and your PC. Our free configuration software, will guide you through any changes you wish to make. To further help save time, the SEM1605TC does not need to be wired to a power supply during the configuration process, it is powered via the USB interface from your PC. The following parameters are configurable :-

INPUT TYPE	LOW RANGE	HIGH RANGE	UNITS	BURNOUT	PUSH BUTTON
<b>THERMOCOUPLES</b> K, J, E, N, T, R, S, L, U, B, C, G	Input @ 4 mA	Input @ 20 mA	°F, °C	Up/Scale Down/Scale	Range or Off

The SEM1605TC is also provided with user push button ranging, allowing adjustments at both 4 mA and 20 mA for a live value. The user adjust function can be locked during configuration if not required. The state LED indicates out of range input during normal operation, during user adjust it is also used to indicate the stage of adjustment.

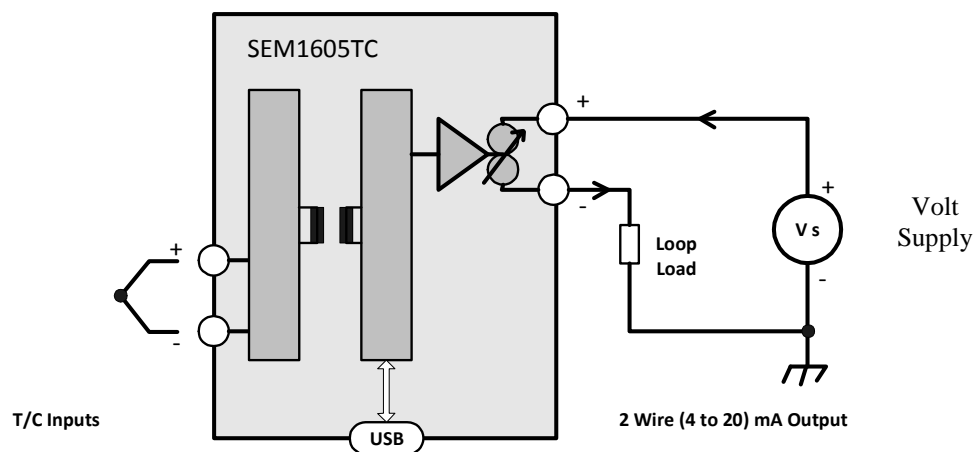

# THERMOCOUPLE DIN RAIL TRANSMITTER

## ➤ SPECIFICATIONS @ 20 °C

ELECTRICAL SENSOR INPUTS		
Input Type	Range	Accuracy / Stability
K	(-200 to 1370) °C	±0.1 % of full scale ± 0.5 °C (plus sensor Error)
J	(-100 to 1200) °C	
N	(-200 to 1300) °C	
E	(-200 to 1000) °C	
T	(-200 to 400) °C	±0.2 % of full scale ± 0.5 °C (plus sensor Error)
R	(0 to 1760) °C	±0.1 % of full scale ± 0.5 °C (plus sensor Error) over range (800 to 1760) °C
S	(0 to 1760) °C	
L	(-100 to 600) °C	±0.1 % of full scale ± 0.5 °C (plus sensor Error)
U	(0 to 600) °C	
B	(-200 to 1300) °C	
C	(0 to 2300) °C	
D	(0 to 2300) °C	
G		
Thermal Stability	(-20 to 50) °C	(± 0.15°C / °C at zero) + (± 0.1°C/ °C at span)
Thermal Stability	(-30 to -20)°C and (50 to 70)°C	Typically as above

AMBIENT SENSOR (Cold Junction)		
Type	Range	Accuracy/Stability
Thermistor 10K Beta 3380	(-40 to 85) °C	±0.5 °C ±0.05 °C/°C

OUTPUT TWO WIRE (4 to 20) mA LOOP		
Range		
Range	(4 to 20) mA	
Range Extremes	(3.8 to 21.5) mA	
Accuracy	(mA output / 2000) or 5 uA (Whichever is the greater)	
Supply Voltage	(12 to 30) V DC	
Loop Effect	± 0.2 uA / V	
Thermal Stability	± 2 uA/ °C	
Max Load	[(Vsupply-12)/20] K Ohms (Example 600 Ohms @ 24 V)	

USB USER INTERFACE		
Type/options/function	Description	Notes
USB 2.0	Micro B	
Baud Rate	19.2 Kbaud	
Sensor Configuration	Select Sensor Type Trim Sensor Offset Preset sensor value (Diagnostics)	TC Type ± 10 °C (± 18 °F)
Loop	Set Range Active Range Set Burnout Preset output loop current (Diagnostics)	
Live data	Read Sensor Temperature Percentage output Read Loop Current Read cold junction	

STATE LED	
Type	Red LED
Action	If mA output < -0.1% or > 100.1 % LED ON
AMBIENT	
Ambient	-30 to 70 °C

ADJUST Buttons	
Off	Locked
Active Range	Range 4mA and 20 mA points against live input

MECHANICAL	
Connection	Screw terminals
Enclosure	DIN RAIL mounted
Weight	Approx. 60 g

APPROVALS	
EMC	EN BS 61326 Industrial emissions

# THERMOCOUPLE DIN RAIL TRANSMITTER

GENERAL	
Isolation	Flash test 250V DC working 48V DC
Update Response Times	0.5 Second update 1 second response
Warm up time	1 minute
Start-up time	8 seconds
Protection	Reverse connection
Enclosure	Device must be installed in an enclosure offering >IP65 Protection
AMBIENT	
Ambient	-30 to 70 °C
Storage	-40 to 85 °C

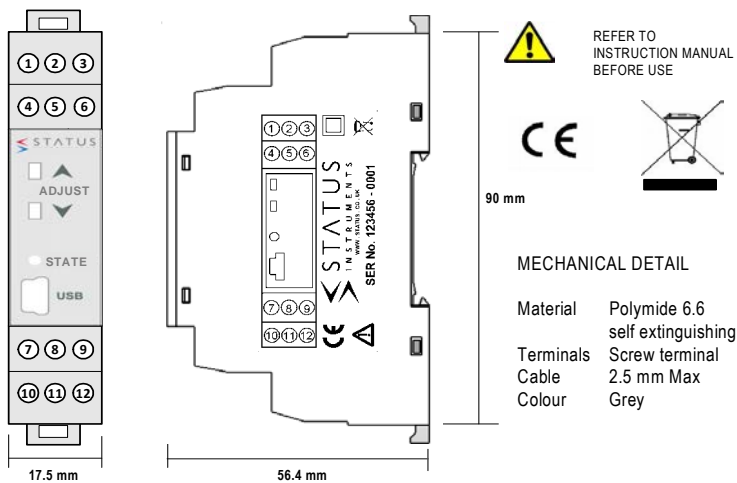

**ORDER CODE : SEM1605/TC**

ASSOCIATED PRODUCTS

USB CABLE A/M TO MINI B/M

USB Link Software

**ORDER CODES**

48-200-0001-01

F0C @ [www.status.co.uk](http://www.status.co.uk) Downloads