

# User Guide

Vaisala Indigo Compatible  
Humidity and Temperature Probes  
**HMP4, HMP5, HMP7, HMP8, HMP9, TMP1**

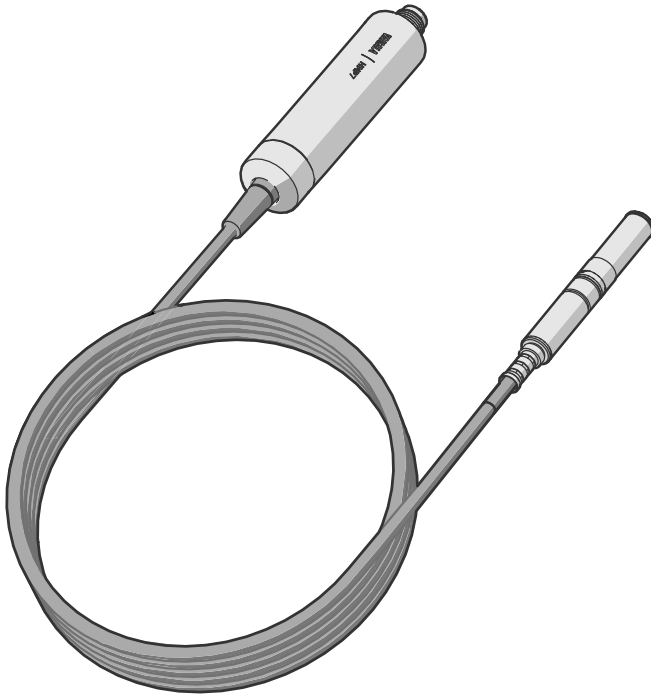

**VAISALA**

PUBLISHED BY

Vaisala Oyj  
Vanha Nurmijärventie 21, FI-01670 Vantaa, Finland  
P.O. Box 26, FI-00421 Helsinki, Finland  
+358 9 8949 1

Visit our Internet pages at [www.vaisala.com](http://www.vaisala.com).

© Vaisala Oyj 2019

No part of this document may be reproduced, published or publicly displayed in any form or by any means, electronic or mechanical (including photocopying), nor may its contents be modified, translated, adapted, sold or disclosed to a third party without prior written permission of the copyright holder. Translated documents and translated portions of multilingual documents are based on the original English versions. In ambiguous cases, the English versions are applicable, not the translations.

The contents of this document are subject to change without prior notice.

Local rules and regulations may vary and they shall take precedence over the information contained in this document. Vaisala makes no representations on this document's compliance with the local

rules and regulations applicable at any given time, and hereby disclaims any and all responsibilities related thereto.

This document does not create any legally binding obligations for Vaisala towards customers or end users. All legally binding obligations and agreements are included exclusively in the applicable supply contract or the General Conditions of Sale and General Conditions of Service of Vaisala.

This product contains software developed by Vaisala or third parties. Use of the software is governed by license terms and conditions included in the applicable supply contract or, in the absence of separate license terms and conditions, by the General License Conditions of Vaisala Group.

## Table of Contents

<b>1.</b>	<b>About This Document</b> .....	7
1.1	Version Information.....	7
1.2	Related Manuals.....	7
1.3	Documentation Conventions.....	8
1.4	Trademarks.....	8
<b>2.</b>	<b>Product Overview</b> .....	9
2.1	Probe Structure.....	9
2.2	Basic Features and Options.....	9
2.3	Output Parameters.....	10
2.4	Additional Features with Indigo Transmitters.....	11
2.5	Safety.....	11
2.6	ESD Protection.....	11
2.7	Regulatory Compliances.....	11
2.7.1	FCC Part 15 Compliance Statement.....	12
2.7.2	Canada ICES-003 Compliance Statement.....	12
<b>3.</b>	<b>Installation</b> .....	13
3.1	HMP4 Probe.....	14
3.2	HMP5 Probe.....	15
3.3	HMP7 Probe.....	16
3.4	HMP8 Probe.....	17
3.4.1	Attaching Ball Valve Kit to Process.....	18
3.5	HMP9 Probe.....	19
3.5.1	Installing HMP9 Through a Cable Gland.....	20
3.6	TMP1 Probe.....	21
3.7	Connector Pinout.....	22
<b>4.</b>	<b>Configuration with Insight Software</b> .....	24
4.1	Vaisala Insight Software.....	24
4.2	Installing the Driver for the USB Service Cable.....	24
4.3	Connecting to Insight Software.....	25
4.4	Configuration Options.....	26
<b>5.</b>	<b>Using Probe with Indigo Transmitters</b> .....	28
5.1	Indigo Overview.....	28
5.2	Attaching Probes to Indigo Transmitters.....	30
5.3	Wireless Configuration Interface Overview.....	30
5.4	Connecting to Wireless Configuration Interface.....	31
5.5	Logging in to Wireless Configuration Interface.....	32
<b>6.</b>	<b>Maintenance</b> .....	33
6.1	Cleaning the Probe.....	33
6.1.1	Chemical Tolerance.....	33
6.2	Changing the Probe Filter.....	34

6.3	Calibration and Adjustment.....	34
6.3.1	Adjustment Points and Requirements.....	35
6.3.2	Adjusting Measurement with Insight Software.....	35
6.3.3	Adjusting Measurement with Indigo 200 Transmitter.....	36
<b>7.</b>	<b>Troubleshooting.....</b>	<b>41</b>
7.1	Problem Situations.....	41
7.2	Error Messages.....	41
<b>8.</b>	<b>Technical Data.....</b>	<b>44</b>
8.1	HMP4 Specifications.....	44
8.2	HMP5 Specifications.....	46
8.3	HMP7 Specifications.....	49
8.4	HMP8 Specifications.....	52
8.5	HMP9 Specifications.....	54
8.6	TMP1 Specifications.....	56
8.7	Dimension Drawings.....	58
8.8	Spare Parts and Accessories.....	62
<b>Appendix A:</b>	<b>Modbus Reference.....</b>	<b>68</b>
A.1	Default Communication Settings.....	68
A.2	Function Codes.....	68
A.3	Data Encoding.....	68
A.3.1	32-Bit Floating Point or Integer Format.....	69
A.3.2	16-Bit Integer Format.....	69
A.4	Modbus Registers.....	69
A.4.1	Measurement Data Registers.....	70
A.4.2	Configuration Registers.....	72
A.4.3	Device Identification Objects.....	75
A.4.4	Status Registers.....	76
A.4.5	Test Value Registers.....	77
A.4.6	Modbus Communication Examples.....	78
<b>Online Store.....</b>		<b>83</b>
<b>Warranty.....</b>		<b>83</b>
<b>Technical Support.....</b>		<b>83</b>
<b>Recycling.....</b>		<b>83</b>

## List of Figures

Figure 1	Probe Parts.....	9
Figure 2	Example Installation of HMP8 Model.....	13
Figure 3	HMP4 Probe Dimensions.....	14
Figure 4	HMP5 Probe Dimensions.....	15
Figure 5	Optional Mounting Flange 210696 Dimensions.....	15
Figure 6	HMP7 Probe Dimensions.....	16
Figure 7	HMP8 Probe Dimensions.....	17
Figure 8	HMP9 Probe Dimensions.....	19
Figure 9	Installing HMP9 Probe Head Through a Cable Gland.....	20
Figure 10	TMP1 Probe Dimensions.....	21
Figure 11	M12/5 Male Connector Pinout.....	22
Figure 12	RS-485 Wiring.....	22
Figure 13	Connecting Probe to Insight.....	26
Figure 14	HMP5 in Insight Software.....	27
Figure 15	HMP7 Attached to Indigo 200 Transmitter.....	28
Figure 16	HMP7 Attached to Indigo 200 Transmitter with a Cable.....	29
Figure 17	Attaching the Probe to Indigo 200 Series.....	30
Figure 18	Enabling and Accessing Indigo's Wireless Configuration Interface.....	31
Figure 19	Indigo Login View.....	32
Figure 20	Calibration Page in the Indigo 200 Wireless Configuration Interface.....	39
Figure 21	HMP4 Humidity Measurement Accuracy as a Function of Temperature (Including Non-Linearity and Repeatability).....	44
Figure 22	HMP4 Temperature Measurement Accuracy over Full Range (Including Non-Linearity and Repeatability).....	45
Figure 23	HMP5 Humidity Measurement Accuracy as a Function of Temperature (Including Non-Linearity and Repeatability).....	47
Figure 24	HMP5 Temperature Measurement Accuracy over Full Range (Including Non-Linearity and Repeatability).....	47
Figure 25	HMP7 Humidity Measurement Accuracy as Function of Temperature (Including Non-Linearity and Repeatability).....	50
Figure 26	HMP7 Temperature Measurement Accuracy over Full Range (Including Non-Linearity and Repeatability).....	50
Figure 27	HMP8 Humidity Measurement Accuracy as a Function of Temperature (Including Non-Linearity and Repeatability).....	52
Figure 28	HMP8 Temperature Measurement Accuracy over Full Range (Including Non-Linearity and Repeatability).....	53
Figure 29	TMP1 Temperature Measurement Accuracy over Full Range (Including Non-Linearity and Repeatability).....	56
Figure 30	HMP4 Probe Dimensions.....	58
Figure 31	HMP5 Probe Dimensions.....	59
Figure 32	HMP7 Probe Dimensions.....	59
Figure 33	HMP8 Probe Dimensions.....	60

Figure 34	Optional Ball Valve Installation Kit Dimensions.....	60
Figure 35	HMP9 Probe Dimensions.....	61
Figure 36	TMP1 Probe Dimensions.....	61
Figure 37	Optional Duct Kit 215003 Dimensions.....	62

## List of Tables

Table 1	Document Versions (English).....	7
Table 2	Related Manuals.....	7
Table 3	Availability of Output Parameters.....	10
Table 4	Suitability of Cleaning Agents.....	33
Table 5	Troubleshooting Table.....	41
Table 6	Measurement Performance.....	44
Table 7	SI Traceable Calibration.....	45
Table 8	Operating Environment.....	45
Table 9	Inputs and Outputs.....	45
Table 10	Mechanical Specifications.....	46
Table 11	Measurement Performance.....	46
Table 12	SI Traceable Calibration.....	48
Table 13	Operating Environment.....	48
Table 14	Inputs and Outputs.....	48
Table 15	Mechanical Specifications.....	48
Table 16	Measurement Performance.....	49
Table 17	SI Traceable Calibration.....	50
Table 18	Operating Environment.....	51
Table 19	Inputs and Outputs.....	51
Table 20	Mechanical Specifications.....	51
Table 21	Measurement Performance.....	52
Table 22	SI Traceable Calibration.....	53
Table 23	Operating Environment.....	53
Table 24	Inputs and Outputs.....	53
Table 25	Mechanical Specifications.....	54
Table 26	Measurement Performance.....	54
Table 27	SI Traceable Calibration.....	55
Table 28	Operating Environment.....	55
Table 29	Inputs and Outputs.....	55
Table 30	Mechanical Specifications.....	56
Table 31	Measurement Performance.....	56
Table 32	SI Traceable Calibration.....	57
Table 33	Operating Environment.....	57
Table 34	Inputs and Outputs.....	57
Table 35	Mechanical Specifications.....	57
Table 36	Accessories.....	62
Table 37	Accessories.....	63
Table 38	Accessories.....	64
Table 39	Accessories.....	65
Table 40	Accessories.....	66
Table 41	Accessories.....	66
Table 42	Default Modbus Serial Communication Settings.....	68
Table 43	Modbus Function Codes.....	68
Table 44	16-bit Signed Integer Format Details.....	69
Table 45	Floating Point Measurement Data Registers (Read-Only).....	70

Table 46	Integer Measurement Data Registers (Read-Only).....	71
Table 47	Modbus Configuration Data Registers (Writable).....	72
Table 48	Device Identification Objects.....	75
Table 49	Modbus Status Data Registers (Read-Only).....	76
Table 50	Error Codes in Register 0203 <sub>hex</sub> .....	77
Table 51	Modbus Test Registers (Read-Only).....	77



# 1. About This Document

## 1.1 Version Information

This document provides instructions for installing, using, and maintaining Vaisala HUMICAP® Humidity and Temperature Probes HMP4, HMP5, HMP7, HMP8, HMP9, and Temperature Probe TMP1.

Table 1 Document Versions (English)

Document Code	Date	Description
<i>M212022EN-C</i>	June 2019	<p>This document. Applicable from software version 1.0.9 onward. Added content for HMP9 probe model. Other added content:</p> <ul style="list-style-type: none"> <li>• <a href="#">Output Parameters (page 10)</a></li> <li>• <a href="#">Adjusting Measurement with Indigo 200 Transmitter (page 36)</a></li> <li>• <a href="#">Problem Situations (page 41)</a></li> <li>• <a href="#">Error Messages (page 41)</a></li> <li>• <a href="#">Status Registers (page 76)</a></li> </ul> <p>Updated content:</p> <ul style="list-style-type: none"> <li>• Updated technical specifications and dimension drawings of probe models</li> <li>• Updated presentation of Modbus register maps</li> <li>• Corrected numbering of decimal registers in section <a href="#">Measurement Data Registers (page 70)</a></li> </ul>
<i>M212022EN-B</i>	June 2018	<p>Applicable from software version 1.0.6 onward. Updated instructions for connecting to Indigo transmitters. Updated sections <a href="#">Measurement Data Registers (page 70)</a> and <a href="#">Configuration Registers (page 72)</a>.</p>
<i>M212022EN-A</i>	November 2017	First version.

## 1.2 Related Manuals

Table 2 Related Manuals

Document Code	Name
<i>M211982EN</i>	<i>HMP4, HMP5, HMP7, HMP8, HMP9, and TMP1 Quick Guide</i>

## 1.3 Documentation Conventions



**WARNING! Warning** alerts you to a serious hazard. If you do not read and follow instructions carefully at this point, there is a risk of injury or even death.



**CAUTION! Caution** warns you of a potential hazard. If you do not read and follow instructions carefully at this point, the product could be damaged or important data could be lost.



**Note** highlights important information on using the product.



**Tip** gives information for using the product more efficiently.



Lists tools needed to perform the task.



Indicates that you need to take some notes during the task.

## 1.4 Trademarks

Vaisala® and HUMICAP® are registered trademarks of Vaisala Oyj.

All other product or company names that may be mentioned in this publication are trade names, trademarks, or registered trademarks of their respective owners.

## 2. Product Overview

HMP series probes are humidity and temperature measurement probes with a digital output (Modbus protocol). The probes are designed for demanding humidity and temperature measurement applications. Each probe model has a 2 m (6.5 ft) cable between the probe body and the probe head.

The probes are compatible with Vaisala Indigo transmitters. They can also be connected to Vaisala Insight software for configuration, diagnostics, and temporary online monitoring.

### 2.1 Probe Structure

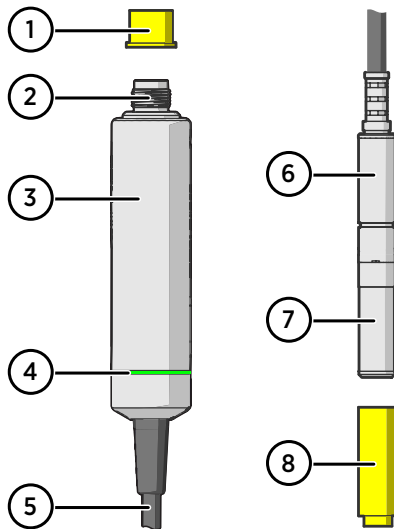

Figure 1 Probe Parts

- 1 Protection cap (remove before use)
- 2 5-pin M12 connector
- 3 Probe body with type label
- 4 Status indicator:
  - Green Power on and probe online, flashes when communicating
  - Red Error
  - Off Power off or indicator disabled
- 5 Probe cable (do not cut)
- 6 Probe head (HMP7 model shown)
- 7 Location of sensors on the probe head. HMP4, HMP5, HMP7, and HMP8 models have a removable filter over the sensors that can be replaced if it gets dirty or damaged.
- 8 Protection cap (remove before use)

### 2.2 Basic Features and Options

- Comprehensive list of output parameters. For example: relative humidity, temperature, dew point temperature, wet-bulb temperature, absolute humidity, mixing ratio, water vapor pressure, enthalpy. Humidity parameters available only on HMP models.
- Sensor purge provides superior chemical resistance (HMP models only)
- Probe and sensor warming functions minimize condensation on probe (HMP models only)
- Traceable calibration certificate:
  - HMP models: 5 points for humidity, 1 point for temperature
  - TMP1: 2 points for temperature
- Standalone Modbus RTU over RS-485
- Plug & play compatible with Indigo series of transmitters

- Can be connected to Vaisala Insight PC software for configuration, diagnostics, and temporary online monitoring

## 2.3 Output Parameters



On HMP probe models, the values of all available output parameters are always locked when chemical purge or extra heat functions are heating the sensor.

- Output parameter is available
- ◐ Output parameter is available but its value is locked during sensor warming or probe heating (HMP7 only) functions unless temperature is written to register 0334<sub>hex</sub> from an external source
- Output parameter is not available on this model

Table 3 Availability of Output Parameters

Register Description	HMP4	HMP5	HMP7	HMP8	HMP9	TMP1
Relative humidity	◐	◐	◐	◐	◐	–
Temperature	◐	◐	◐	◐	◐	●
Dew point temperature	●	●	●	●	●	–
Dew/frost point temperature	●	●	●	●	●	–
Dew/frost point temperature at 1 atm	●	●	●	●	●	–
Dew point temperature at 1 atm	●	●	●	●	●	–
Absolute humidity	◐	◐	◐	◐	◐	–
Mixing ratio	●	●	●	●	●	–
Wet-bulb temperature	◐	◐	◐	◐	◐	–
Water concentration	●	●	●	●	●	–
Water vapor pressure	●	●	●	●	●	–
Water vapor saturation pressure	◐	◐	◐	◐	◐	●
Enthalpy	◐	◐	◐	◐	◐	–
Dew point temperature difference	◐	◐	◐	◐	◐	–
Absolute humidity at NTP	◐	◐	◐	◐	◐	–
Water mass fraction	●	●	●	●	●	–

## 2.4 Additional Features with Indigo Transmitters

Connecting the probe to an Indigo transmitter provides a range of additional options for outputs, measurement viewing, status monitoring, and configuration interface access.

Examples of additional features available with Indigo transmitters include:

- 3.5" TFT LCD color display or non-display model with LED indicator
- Digital output or 3 analog outputs (depending on the transmitter model)
- 2 configurable relays
- Wireless browser-based configuration interface for mobile devices and computers (IEEE 802.11 b/g/n WLAN)

The selection of available additional features (for example, output and connectivity options) varies depending on the Indigo transmitter model. For more information on Indigo transmitters, see [www.vaisala.com/indigo](http://www.vaisala.com/indigo).

## 2.5 Safety



**WARNING!** When returning a product for calibration or repair, make sure it has not been exposed to dangerous contamination, and is safe to handle without special precautions.



**CAUTION!** Do not attempt to open the probe body. There are no user serviceable parts inside the probe body.



Information on spare parts, accessories, and calibration products is available online at [www.vaisala.com](http://www.vaisala.com) and [store.vaisala.com](http://store.vaisala.com).

## 2.6 ESD Protection

Electrostatic Discharge (ESD) can cause immediate or latent damage to electronic circuits. Vaisala products are adequately protected against ESD for their intended use. However, it is possible to damage the product by delivering an electrostatic discharge when touching, removing or inserting any objects inside the equipment housing.

Avoid touching component contacts or connectors when working with the device.

## 2.7 Regulatory Compliances

The probes are in conformity with the provisions of the following EU directives:

- RoHS Directive
- EMC Directive

Conformity is shown by compliance with the following standards:

- EN 50581: Technical documentation for the assessment of electrical and electronic products with respect to the restriction of hazardous substances.
- EN 61326-1: Electrical equipment for measurement, control, and laboratory use – EMC requirements – intended for use in industrial locations.
- EN 55032: Information technology equipment – Radio disturbance characteristics – Limits and methods of measurement.

## 2.7.1 FCC Part 15 Compliance Statement

This equipment has been tested and found to comply with the limits for a Class B digital device, pursuant to Part 15 of the FCC rules. These limits are designed to provide reasonable protection against harmful interference in a residential installation. This equipment generates, uses and can radiate radio frequency energy and, if not installed and used in accordance with the instructions, may cause harmful interference to radio communications. However, there is no guarantee that the interference will not occur in a particular installation. If this equipment does cause harmful interference to radio or television reception, which can be determined by turning the equipment off and on, the user is encouraged to try to correct the interference by one or more of the following measures:

- Reorient or relocate the receiving antenna.
- Increase the separation between the equipment and receiver.
- Connect the equipment into an outlet on a circuit different from that of the receiver.
- Consult the dealer or an experienced radio/TV technician for help.



**CAUTION!** Changes or modifications to this equipment not expressly approved by the party responsible for compliance could void the user's authority to operate the equipment.

## 2.7.2 Canada ICES-003 Compliance Statement

This Class B digital apparatus complies with Canadian ICES-003.

Cet appareil numérique de la classe B est conforme à la norme NMB-003 du Canada.

### 3. Installation

When you choose the installation location for the probe, consider the following:

- Verify the operating environment specification of the probe model. The probe head typically has a much wider operating temperature range than the probe body.
- If the temperature of the measured environment differs greatly from ambient temperature, the entire probe head and preferably plenty of cable must be inside the measured environment. This prevents measurement inaccuracy caused by heat conduction along the cable.
- Probe mounting options are model-specific.

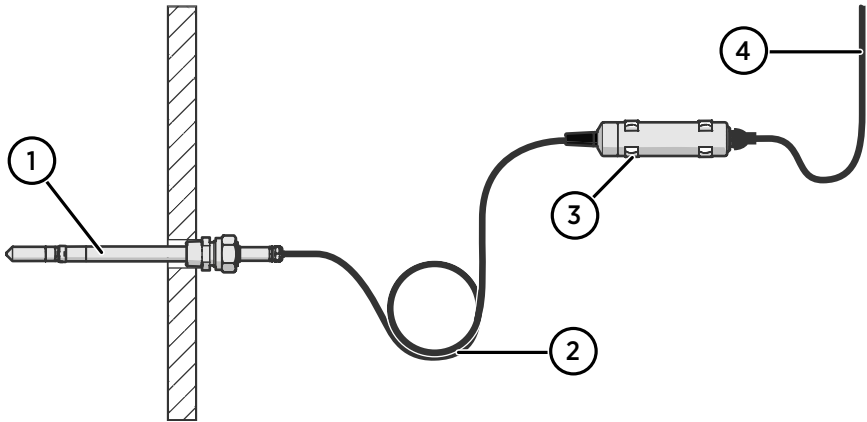

Figure 2 Example Installation of HMP8 Model

- 1 Mount the probe head horizontally to prevent any water condensing on the probe head from running to the sensors.
- 2 Let the cable hang loosely to prevent condensed water from running along the cable to the probe head.
- 3 Attach the probe body to a wall or other surface using the two mounting clips (Vaisala item 243257SP) supplied with the probe. Each clip attaches to the installation surface with one screw (screw hole  $\varnothing$  4.2 mm).
- 4 Cable to Modbus master or Indigo transmitter.

#### More Information

- [Default Communication Settings \(page 68\)](#)

### 3.1 HMP4 Probe

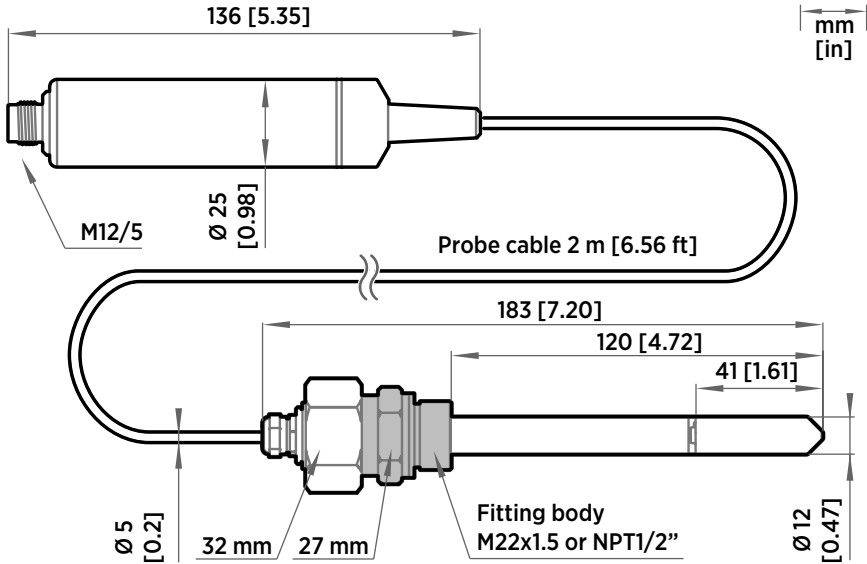

Figure 3 HMP4 Probe Dimensions

Vaisala HUMICAP® Humidity and Temperature Probe HMP4 is designed for high-pressure applications such as compressed air systems in maritime, breathing air, and industrial applications, where measurement performance and chemical tolerance are essential.

- Temperature measurement range -70 ... +180 °C (-94 ... +356 °F)
- Operating pressure 0 ... 10 MPa (0 ... 100 bar)
- Operating temperature range for probe body -40 ... +80 °C (-40 ... +176 °F)
- M22x1.5 and NPT1/2" probe fittings included
- Sintered AISI316L filter standard in delivery



## 3.2 HMP5 Probe

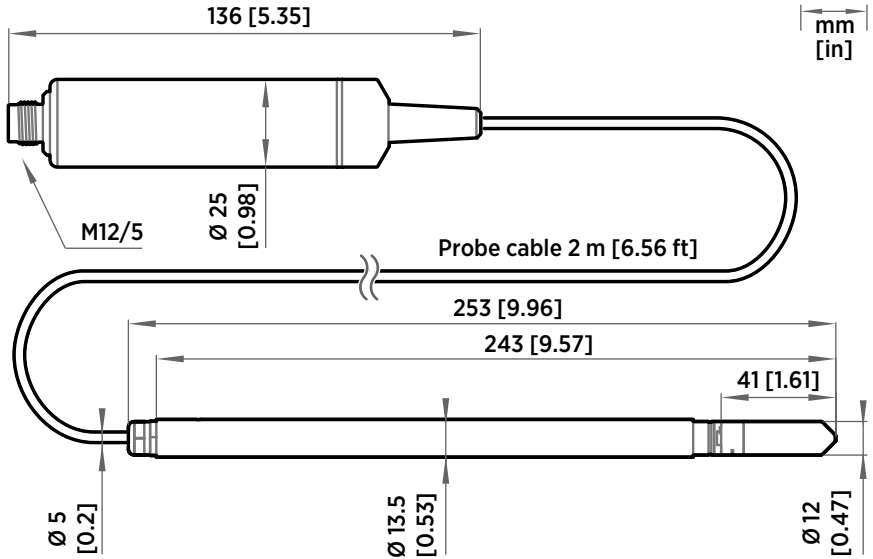

Figure 4 HMP5 Probe Dimensions

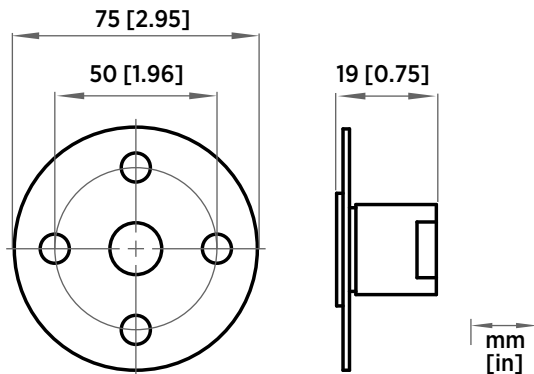

Figure 5 Optional Mounting Flange 210696 Dimensions

Vaisala HUMICAP® Humidity and Temperature Probe HMP5 is designed for high-temperature applications such as baking ovens, pasta dryers, and industrial drying kilns, where measurement performance and chemical tolerance are essential.

- Temperature measurement range -70 ... +180 °C (-94 ... +356 °F)

- Operating temperature range for probe body -40 ... +80 °C (-40 ... +176 °F)
- 250-mm (9.84 in) probe allows easy process installation through insulation
- Sintered AISI316L filter standard in delivery

### 3.3 HMP7 Probe

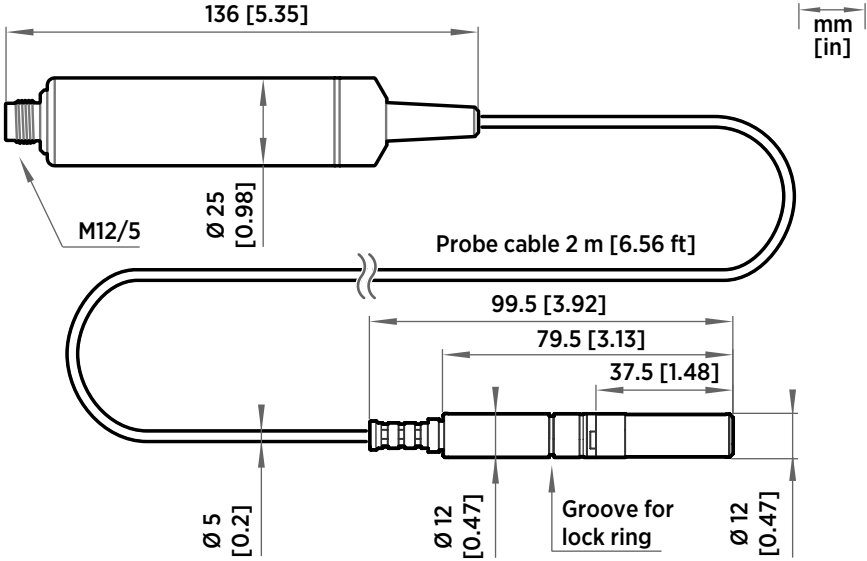

Figure 6 HMP7 Probe Dimensions

Vaisala HUMICAP® Humidity and Temperature Probe HMP7 is designed for applications that involve constant high humidity or rapid changes in humidity, such as drying and test chambers, combustion air, and other humidifiers and meteorological measurements, where measurement performance and chemical tolerance are essential.

- Temperature measurement range -70 ... +180 °C (-94 ... +356 °F)
- Operating temperature range for probe body -40 ... +80 °C (-40 ... +176 °F)
- Probe heating and sensor warming functions minimize condensation on probe
- Vapor and pressure proof construction
- Stainless steel mesh filter standard in delivery

### Probe Heating

HMP7 supports probe heating. Probe heating heats up not only the sensor, but the entire probe head. When probe temperature is heated above dew point temperature, condensation on the probe can be avoided while measuring the dew point temperature of the process.

Probe heating is disabled by default. If you enable probe heating, output parameters that are dependent on temperature measurement (such as relative humidity) are locked whenever probe is heated unless the true temperature of the measured environment is updated to the temperature compensation register of the probe from another measurement instrument (for example, the TMP1 probe). Output parameters such as dew point temperature that can be measured or calculated without this external temperature information are available even without the temperature input.

### 3.4 HMP8 Probe

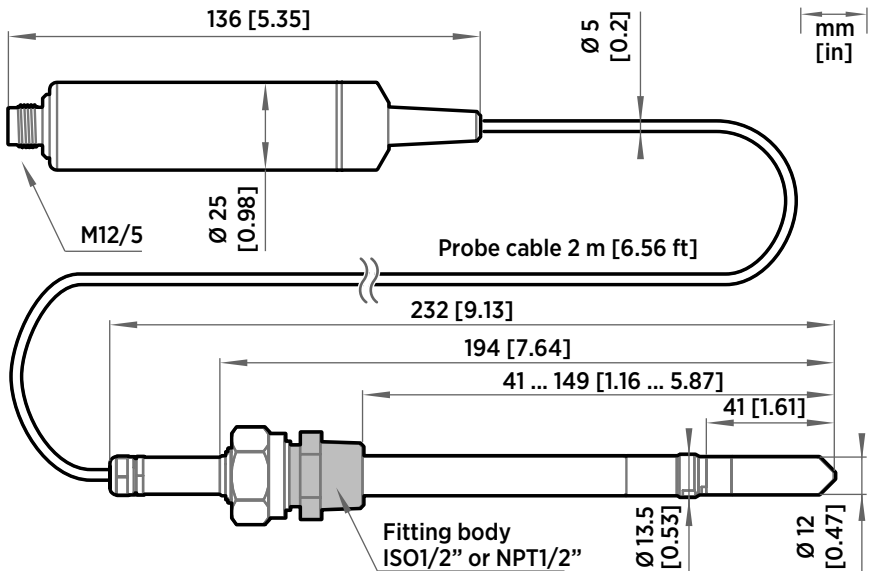
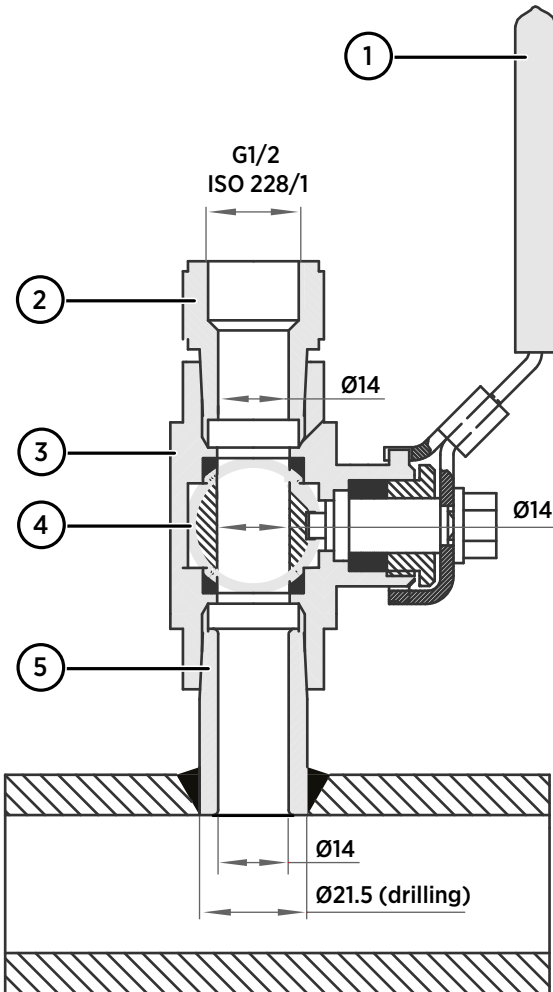

Figure 7 HMP8 Probe Dimensions

Vaisala HUMICAP® Humidity and Temperature Probe HMP8 is designed for pressurized applications in compressed air systems, refrigerant dryers, and other pressurized industrial applications, where easy insertion and removal of the probe and adjustable installation depth into the pipeline are needed.

- Temperature measurement range -70 ... +180 °C (-94 ... +356 °F)
- Operating temperature range for probe body -40 ... +80 °C (-40 ... +176 °F)
- Operating pressure 0 ... 4 MPa (0 ... 40 bar)
- Probe installation depth can be freely adjusted and probe can be hot-swapped from pressurized pipelines with an installation valve
- ISO1/2" and NPT1/2" probe fittings and press handle included
- Sintered AISI316L filter standard in delivery

### 3.4.1 Attaching Ball Valve Kit to Process



- 1 Ball valve handle: must point to the same direction as the ball valve body when installing.
- 2 Extension nipple, threads G1/2 ISO228/1 and R1/2 ISO7/1.
- 3 Ball valve body. When tightening the assembly, turn only from the ball valve body.
- 4 Ball of the ball valve.
- 5 Welding joint, threads R1/2 ISO7/1.

- ▶ 1. Attach the welding joint to the process pipe or chamber.
2. Apply a sealant (MEGA-PIPE EXTRA No 7188 or LOCTITE® No 542 +activ. No 7649) on the threads of the welding joint and screw the bottom of the ball valve onto the welding joint.
3. Tighten the ball valve assembly by turning from the ball valve body.



**CAUTION!** Tightening the ball valve kit by turning the extension nipple can break the sealing. Tighten the ball valve assembly only from the ball valve body.

4. If you need to cap the ball valve assembly before installing or after removing the probe, attach a blanking nut to close the top of the valve.

### 3.5 HMP9 Probe

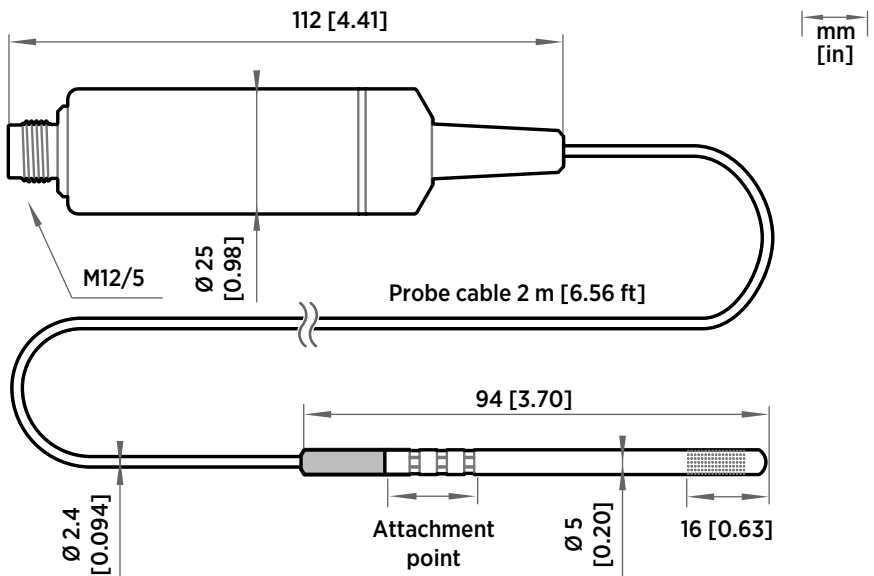

Figure 8 HMP9 Probe Dimensions

Vaisala HUMICAP® Humidity and Temperature Probe HMP9 is designed for easy installation into rapidly changing environments where fast response time, measurement performance, and chemical tolerance are essential.

The probe head can be mounted through thin metal walls using the included cable gland or mounting grommet. Two grommets are included: small one for 6.5 mm diameter hole, and large one for 12.5 mm diameter hole.

You can also attach the probe head directly using a zip tie. The probe head should be attached from the point near the black plastic part.

- Temperature measurement range -40 ... +120 °C (-40 ... +248 °F)
- Operating temperature range for probe body -40 ... +60 °C (-40 ... +140 °F)
- Integrated filter (non-replaceable)



**CAUTION!** Do not damage the probe head by bending, crushing, or striking it. Avoid overtightening when installing the probe head through a cable gland.

### 3.5.1 Installing HMP9 Through a Cable Gland

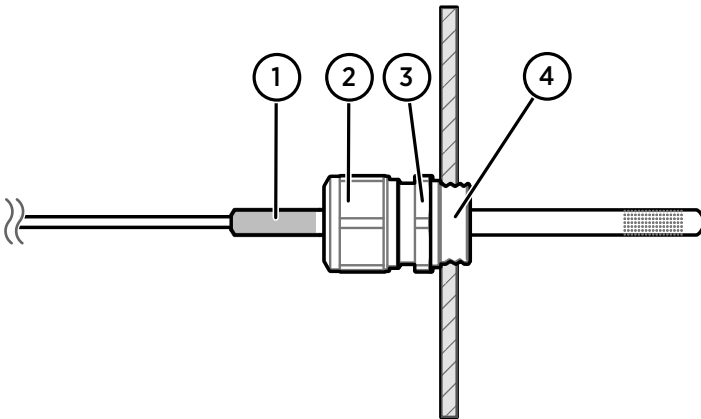

Figure 9 Installing HMP9 Probe Head Through a Cable Gland

- 1 Black plastic part of the HMP9 probe head
- 2 Nut for tightening the probe in place
- 3 Base of the cable gland
- 4 M10×1.5 threads of the cable gland



- M10×1.5 cable gland (included with HMP9 probe)
- Drill with 8.5 mm bit
- M10×1.5 threading tap
- 13 mm wrench

- ▶ 1. Drill a 8.5 mm diameter hole in the installation location.

2. Use a threading tap to create a M10×1.5 thread in the hole.
3. Install the base of the cable gland in the hole and tighten with a 13 mm wrench.
4. Insert the seal of the cable gland in the base and place the nut of the cable gland over the probe head.
5. Insert the probe head in the cable gland up to the black plastic part of the probe head. Leave the black plastic part entirely outside the cable gland. Tighten the cable gland to finger tightness.
6. Tighten the nut of the cable gland with a 13 mm wrench until the probe head stops moving. Do not overtighten.

### 3.6 TMP1 Probe

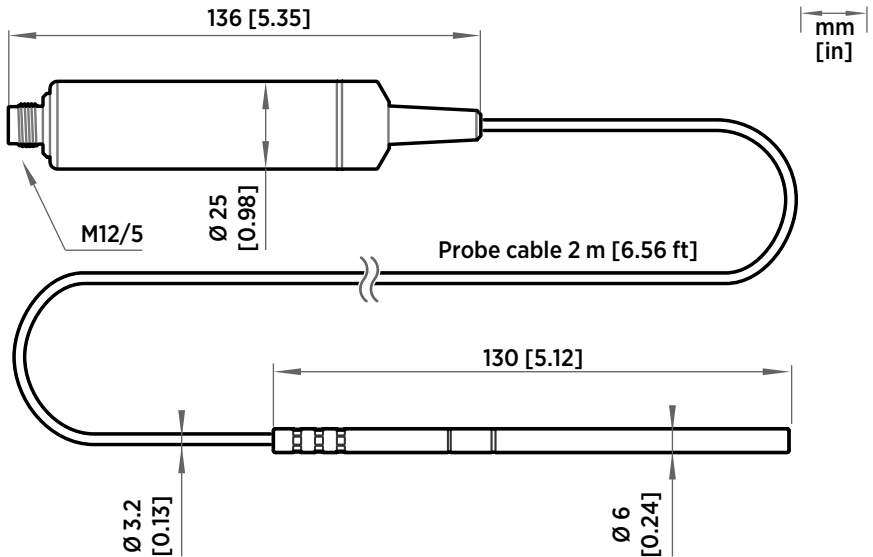

Figure 10 TMP1 Probe Dimensions

Vaisala Temperature Probe TMP1 is designed for demanding temperature measurements in industrial applications such as pharmaceutical industry and calibration laboratories, where accuracy and robustness are essential.

- Temperature measurement range -70 ... +180 °C (-94 ... +356 °F)
- Operating temperature range for probe body -40 ... +80 °C (-40 ... +176 °F)

### 3.7 Connector Pinout

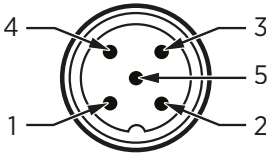

Figure 11 M12/5 Male Connector Pinout

Pin #	Function	Notes	Wire Colors in Vaisala Cables
1	Power supply	Supply voltage: • HMP7: 18 ... 30 VDC • Other models: 15 ... 30 VDC Typical current 10 mA, max. 500 mA.	Brown
2	RS-485 -		White
3	Power GND and RS-485 common		Blue
4	RS-485 +		Black
5	Not connected		Gray

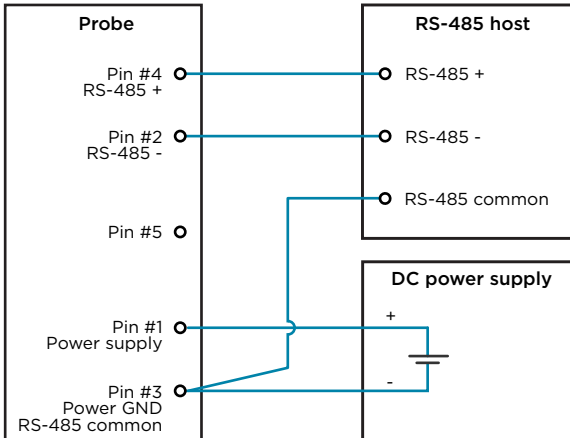

Figure 12 RS-485 Wiring





Recommended maximum length of the RS-485 line is 30 m (98 ft).

## 4. Configuration with Insight Software

### 4.1 Vaisala Insight Software

Vaisala Insight software is a configuration software for Indigo-compatible devices. The supported operating systems are Windows 7 (64-bit), Windows 8.1 (64-bit), and Windows 10 (64-bit).

With the Insight software, you can:

- See probe information and status
- See real-time measurement
- Calibrate and adjust the probe
- Configure probe features such as measurement filtering, chemical purge, heating, and serial communication

Download Vaisala Insight software at [www.vaisala.com/insight](http://www.vaisala.com/insight).

The probe can be connected to Vaisala Insight software using a Vaisala USB cable (no. 242659).

### 4.2 Installing the Driver for the USB Service Cable



Only Windows® operating systems are supported by the driver of the USB service cable.

- ▶ 1. Connect the USB service cable to a USB port on your computer. Windows® detects the new device and installs the appropriate driver.
2. Open **Devices and Printers** from the Windows® Start menu. Use search to find it if necessary (search for "devices").

3. Locate the cable in the list of devices:
  - If the device is listed as **Vaisala USB Device** with a COM port number in brackets, the cable is ready for use. **Note the COM port number, you will need it later.**
  - If the device is listed as **Vaisala USB Instrument Cable** without a COM port number listed, you must install the driver manually.

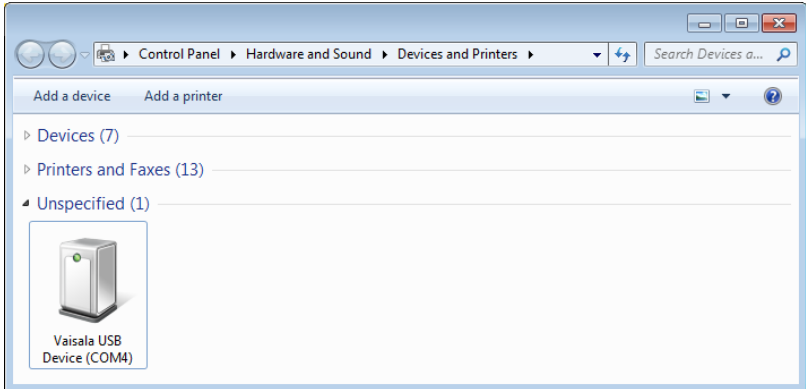

4. To install the driver manually:
  - a. Disconnect the USB service cable from the computer.
  - b. Download the Vaisala USB driver at <http://www.vaisala.com/software> (select the appropriate USB Instrument Driver Setup for your cable).
  - c. Run the USB driver installation program *Vaisala USB Device Driver Setup.exe*. Accept the installation defaults.
  - d. Go back to [step 1](#) and verify that the driver installation works as expected.

## 4.3 Connecting to Insight Software



- Computer with Vaisala Insight software installed
- USB connection cable (no. 242659)

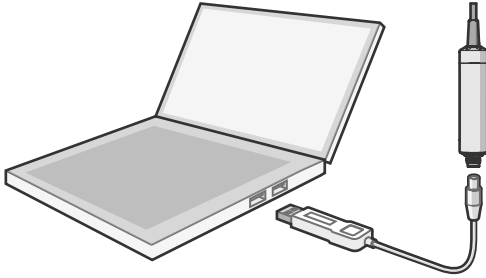



Figure 13 Connecting Probe to Insight

1. Open the Insight software.
2. Connect the USB cable to a free USB port on the PC.
3. Connect the probe to the USB cable.
4. Wait for Insight software to detect the probe.

## 4.4 Configuration Options

Select  > **Configure Device** to access configuration options in Insight software.

Available configuration options include all of the Modbus configuration registers (see [Configuration Registers \(page 72\)](#)) and several additional options. Insight software is the recommended way to change the probe configuration.



You can restore the probe back to its default settings using the **Factory Default Settings > Restore Settings** function. Doing this will also clear any user adjustment and restore the latest factory calibration.

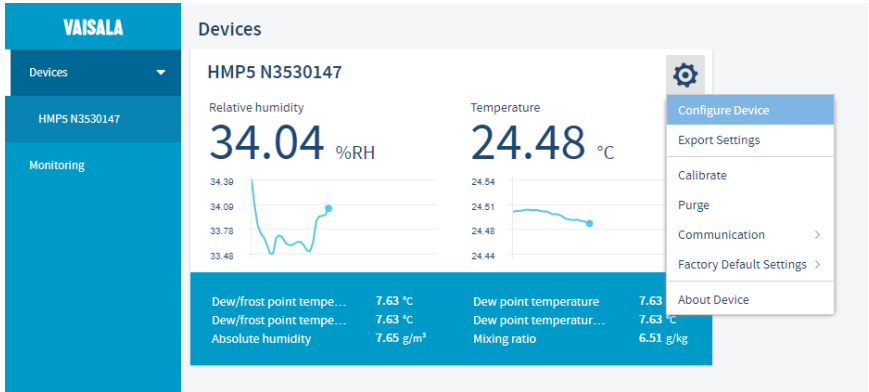

Figure 14 HMP5 in Insight Software

## 5. Using Probe with Indigo Transmitters

### 5.1 Indigo Overview

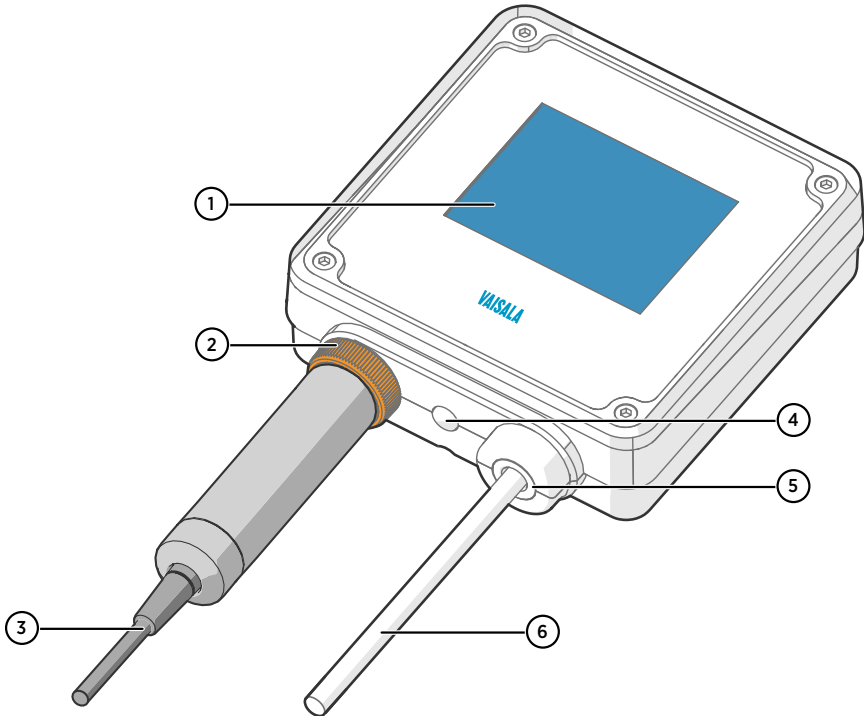

Figure 15 HMP7 Attached to Indigo 200 Transmitter

- 1 3.5" TFT LCD color display: non-display option with LED available for certain models
- 2 Locking wheel: insert probe, hold in place, and turn the wheel counterclockwise
- 3 Cable to probe head
- 4 Wireless configuration interface (WLAN) activation button
- 5 Rubber lead-through with strain relief. Cable feedthrough option also at back of transmitter.
- 6 Input/output cable

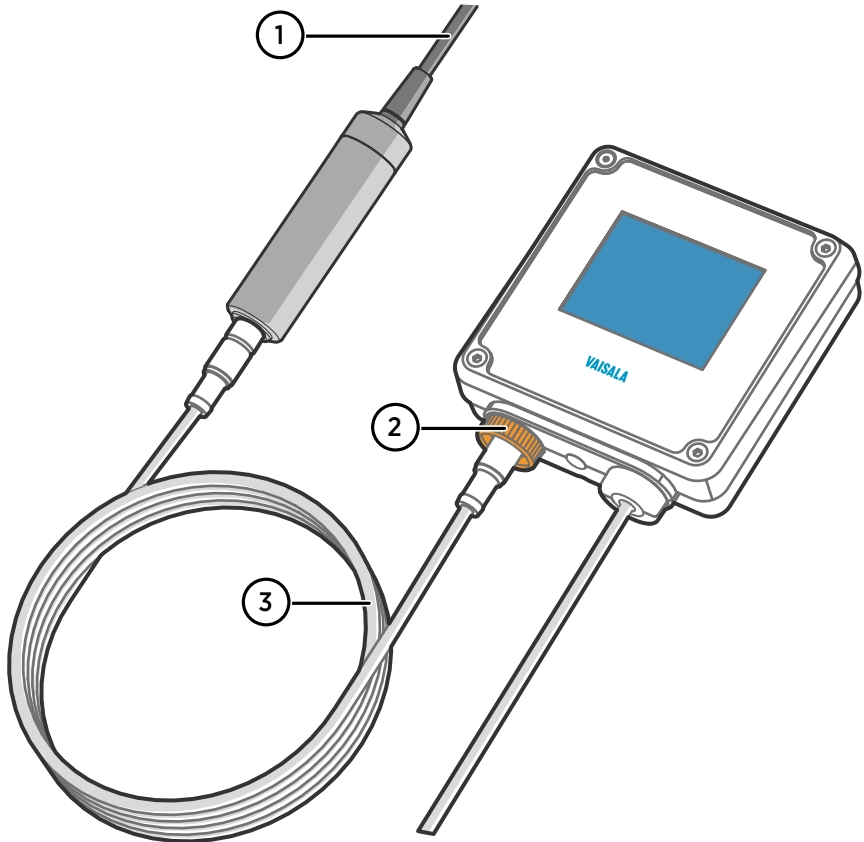

Figure 16 HMP7 Attached to Indigo 200 Transmitter with a Cable

- 1 Cable to probe head
- 2 Locking wheel: insert cable, hold in place, and turn the wheel counterclockwise
- 3 Connection cable

The probe can be connected to Vaisala Indigo transmitters, either directly on the transmitter from the probe's connector, or by using a cable between Indigo and the probe.

Indigo transmitters are host devices that extend the feature set of connected probes with a range of additional options for outputs, configuration access, measurement viewing, and status monitoring.

The selection of available additional features (for example, output and connectivity options) varies depending on the Indigo transmitter model. Depending on the model, a display is available as an optional selection or as a standard feature. In the non-display model, an LED indicator is used for notifications.

## 5.2 Attaching Probes to Indigo Transmitters

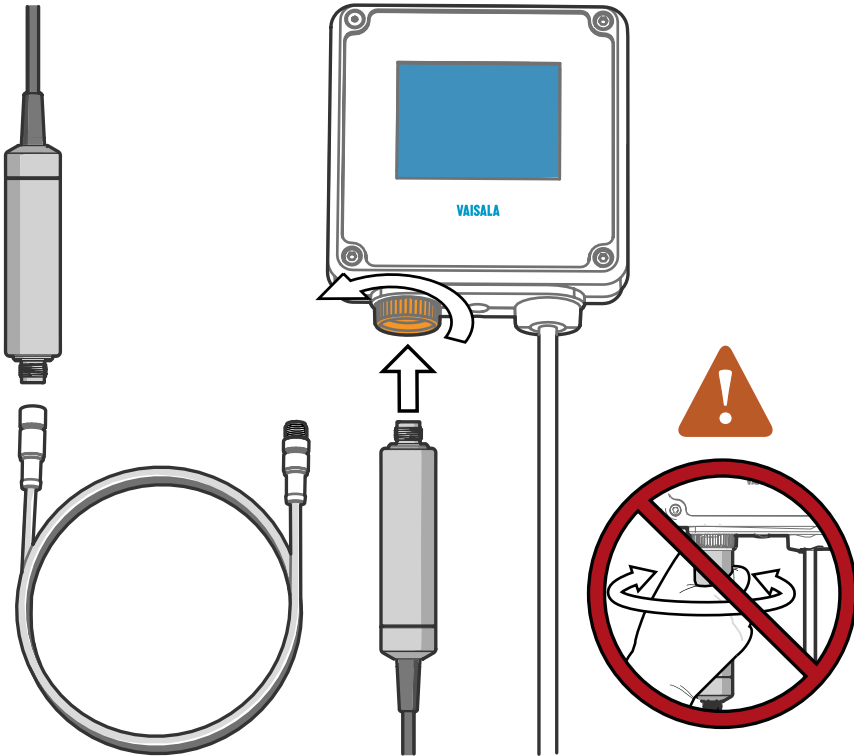

Figure 17 Attaching the Probe to Indigo 200 Series

- ▶ 1. Insert the probe or the connection cable into the transmitter's connector. Use of connection cable is recommended for strain relief.
- 2. Turn the locking wheel of the transmitter to lock the probe or cable in place.  
**Do not turn the probe or the cable itself**, as that will damage the connectors.
- 3. If you are using a connection cable, connect the probe to the cable.
- 4. When the transmitter recognizes the connected probe, it shows a notification message on the display.

## 5.3 Wireless Configuration Interface Overview

The wireless configuration interface has two user levels:



- All users have view-only access (no configuration rights, not password protected).
- Personnel that carry out configuration tasks can log in with an administrative password that allows changing the transmitter and probe settings.

To use the wireless configuration interface to modify the settings of your Indigo transmitter and the connected probe, you must first enable the transmitter's wireless connection and then connect to Indigo with your mobile device or computer. Most major browsers (for example, Firefox, Chrome, Safari, and Internet Explorer) are supported: using the most recent version is recommended.

## 5.4 Connecting to Wireless Configuration Interface

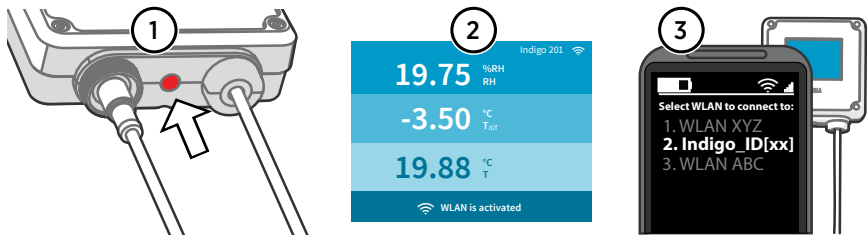

Figure 18 Enabling and Accessing Indigo's Wireless Configuration Interface

- 1 Wireless connection activation button
- 2 Wireless connection indicator (WLAN symbol) on the Indigo display
- 3 Choose Indigo (**Indigo\_ID[xx]**) from your wireless device's list of available connections

## 5.5 Logging in to Wireless Configuration Interface

Figure 19 Indigo Login View

When you open Indigo's wireless configuration interface in your browser, you are prompted to log in. There are 2 available user levels:

- **User**: view-only access available for all users. Does not require a password.
- **Admin**: password-protected access. To change settings, you must log in as admin.

To log in:

- ▶ 1. Enter the user name and password:
  - a. To log in as user (view-only access, no configuration rights), select **User** from the **User name** dropdown. Leave the **Password** field empty.
  - b. To log in as admin (required for configuration), select **Admin** in the **User name** dropdown and type the admin password (default: **12345**) in the **Password** field.
2. Select **Log in** after entering the login credentials. The wireless configuration interface opens in the **Measurements** view.



The user level (**User** or **Admin**) is shown in the upper right corner of all menu views.  
Select the user/admin icon in the upper right corner to change the user level.

## 6. Maintenance

### 6.1 Cleaning the Probe



**CAUTION!** Do not attempt to clean the sensors under the filter in any way.



Do not spray anything directly on the probe head, since that may deposit impurities on the sensors.

You can clean the probe, probe body, and cable by wiping them with a soft, lint-free cloth moistened with water or a suitable cleaning agent, such as isopropyl alcohol. Do not wipe the filter: wiping the filter may block its pores and/or deposit residue on the filter. If the filter is heavily contaminated, replace it.

When cleaning, follow these precautions:

- Avoid touching the filter. If you need to touch the filter, always wear clean gloves (cotton, rubber or similar material). Keep the filter free of any grease or oil.
- Do not scrape the probe or the probe body.
- Do not immerse the probe or the probe body in liquid to clean them.
- Wipe cleaning agents off the probe, probe body, and the cable after cleaning.

After cleaning the probe, it is recommended to perform a chemical purge.

#### 6.1.1 Chemical Tolerance



Avoid exposing the probe to cleaning agents for unnecessarily long periods of time.

Table 4 Suitability of Cleaning Agents

Cleaning Agent	Suitability
Acetone	Suitable
Chlorine disinfectants	Suitable
Ethanol	Suitable
Heptane	Suitable
Isopropyl alcohol	Suitable

## 6.2 Changing the Probe Filter



- New compatible filter
- Clean lint-free gloves



**CAUTION!** Without the filter in place, the sensor is easily damaged – handle the probe head carefully.

- ▶ 1. Put on clean gloves before touching the filter.
2. Turn the filter counter-clockwise to loosen it.
3. Remove the filter from the probe head. Be careful not to touch the sensors with the filter.
4. Install a new filter on the probe head. Tighten the filter properly (recommended force 5 Nm).

## 6.3 Calibration and Adjustment

The probe is fully calibrated and adjusted as shipped from the factory. To maintain the accuracy of the measurement, calibrate and adjust the probe as needed. Typical calibration interval is one year, but depending on the application it may be necessary to check the accuracy more frequently.

When adjustment is necessary, you can have Vaisala calibrate and adjust the probe. To order calibration services from Vaisala, visit [store.vaisala.com](https://store.vaisala.com). You can also do the adjustment yourself using the Insight software.



**WARNING!** When returning a product for calibration or repair, make sure it has not been exposed to dangerous contamination, and is safe to handle without special precautions.



If you think the device is not measuring correctly, calibration and adjustment is not the first thing to do. Check the following first:

- Make sure nothing is interfering with the measurement: heat sources, temperature differences, or condensation.
- Check that there is no moisture on the probe. If the sensor has become wet, wait for it to dry.
- Always wait for the measurement to stabilize.



**Calibration** means comparing the measurement output of the device to a known reference, such as a known environment in a calibration chamber or the output of a reference instrument. Correcting the reading of the device so that it measures accurately is referred to as **adjustment**.

### 6.3.1 Adjustment Points and Requirements

You can adjust the humidity measurement in 1 ... 5 points, and temperature measurement in 1 ... 2 points. Note the following:

- Humidity adjustment in more than two points is available when using Insight software in **Advanced Mode**.
- If you are adjusting in more than one humidity point, make sure the first two points are at least 10 %RH apart.
- The probe will reject adjustments that are too large, that is, greater than 10 %RH for humidity and 0.5 °C for temperature. If the probe appears to need such a large correction, perform a sensor purge and repeat the adjustment procedure. Make sure the measurement has stabilized and the reference environment is reliable. If the required adjustment is still too large, the probe needs to be serviced by Vaisala.



When adjustment of humidity measurement is necessary, Vaisala recommends adjusting in two points, 11 %RH and 75 %RH. These humidities can be produced using the Vaisala HMK15 Humidity Calibrator. Adjustment of temperature measurement is typically not necessary.



### 6.3.2 Adjusting Measurement with Insight Software



- Computer with Windows operating system and Vaisala Insight software installed
- Vaisala USB cable 242659 for connecting the probe
- Reference environment(s) for producing the desired humidity and/or temperature

This procedure can be used to adjust the probe's humidity or temperature measurement. If you want to adjust both, repeat the procedure.

Because stabilization of temperature and humidity takes time, you should expect the adjustment procedure to take at least 30 minutes for each adjustment point.

- ▶ 1. Connect the probe to Insight. See [Connecting to Insight Software \(page 25\)](#).
2. If you intend to adjust humidity measurement, first select  > **Purge** to perform a chemical purge to condition the sensor. Wait a few minutes for purge to complete.
3. Select  > **Calibrate** > **Yes** to switch the probe to calibration mode. In calibration mode, the device will not use functions that may interfere with calibration and adjustment.

4. Select the type of adjustment to perform: **RH adjustment** or **T adjustment**.
5. Define the needed adjustment for the first measurement point:
  - a. Insert the probe head in the reference environment for the first calibration point.
  - b. Wait for the measurement to stabilize fully.
  - c. Click the **Reference value, point 1** text box and enter the reference value of the calibration point. Press **ENTER** or click outside the text box when done.
  - d. The probe automatically enters the measured values for the calibration point.
6. If you want to adjust in more than one point, repeat [step 5](#) for all desired calibration points.



You can adjust humidity measurement in up to five points when Insight is set to **Advanced mode**.

7. Select **Activate adjustment > Yes** to store the adjustment in the probe.
8. Check the message that appears at the top of the screen. If the message indicates that the adjustment is activated successfully, your adjustment is stored in the probe.
9. Select the **Calibration information** tab and update the **Calibration date** and **Calibration text**.
10. Select **Close > Yes** to exit the calibration mode.

### 6.3.3 Adjusting Measurement with Indigo 200 Transmitter



- Indigo 200 transmitter
- Reference environment(s) for producing the desired humidity and/or temperature (see [Adjustment Points and Requirements \(page 35\)](#) for more information)
- Mobile device or computer with an internet browser and a Wi-Fi connection
- Connection cable for connecting the probe to Indigo 200 transmitter (optional)

This procedure can be used to adjust the humidity or temperature measurement of an Indigo-compatible HMP or TMP-series probe. Because stabilization of temperature and humidity takes time, you should expect the adjustment procedure to take at least 30 minutes for each adjustment point.



This procedure assumes the Indigo 200 transmitter is powered on and the probe is connected to it. Refer to the user guide of your Indigo 200 transmitter model for instructions on connecting probes. The user guide also provides more detailed instructions for operating and troubleshooting the wireless connection.

- ▶ 1. Connect to the wireless configuration interface of the Indigo 200 transmitter:
  - a. Press the wireless connection activation button on the bottom of the transmitter.
  - b. Open the wireless connection menu in your mobile device or computer and select **Indigo\_ID[xx]** (transmitter-specific SSID) from the list of available connections.
  - c. If the wireless configuration interface does not launch automatically on your device, start your browser application manually and navigate to address **192.168.1.1**.
  - d. Log in to the interface:
    - User name: **Admin**
    - Password: **12345** (default)



Stay close to the transmitter for a strong wireless signal and the possibility to read on-screen messages from the transmitter's display (display models only). Starting with Indigo 200 firmware version 1.4.0, messages from the probe are also shown through the wireless configuration interface.

2. To adjust humidity measurement:
  - a. If your probe supports the chemical purge feature, wait for the start-up purge to finish or start the purge manually from **Calibration > Configuration > Purge**. Measurement will be frozen for the duration of the purge. Continue when the measured values are changing again.
  - b. Select the **Calibration** tab and select **Start calibration** to start the calibration mode.
  - c. In the **RH adjustment** section of the page, select **Restore factory adjustment** to remove any existing non-factory adjustments.
  - d. Insert the probe head in the reference environment for RH adjustment point 1 (dry point, recommendation 0 ... 35 %RH).
  - e. Wait for the RH and temperature measurements to stabilize fully. This may take more than 30 minutes. Monitor the readings to see when the measurement has stabilized.
  - f. Enter the value of the first reference into the **Reference value, point 1** field. Select outside the text box when done. The probe automatically enters the measured values for the calibration point.
  - g. If you want to adjust humidity measurement in two points, repeat steps [step 2.d](#) ... [step 2.f](#) for RH adjustment point 2 (wet point, recommendation 65 ... 85 %RH).
  - h. Select **Activate adjustment** to store the adjustment in the probe.



When the adjustment is successful, the fields for reference and measured values are cleared. The message **Adjustment activated successfully** appears on the local display (display models only). If the adjustment fails, the fields are not cleared. A message on the transmitter's display will indicate the reason. For example, if the humidity adjustment would be over the maximum 10 %RH allowed by the probe, the message **Cumulative adjustment too large** appears on the local display.



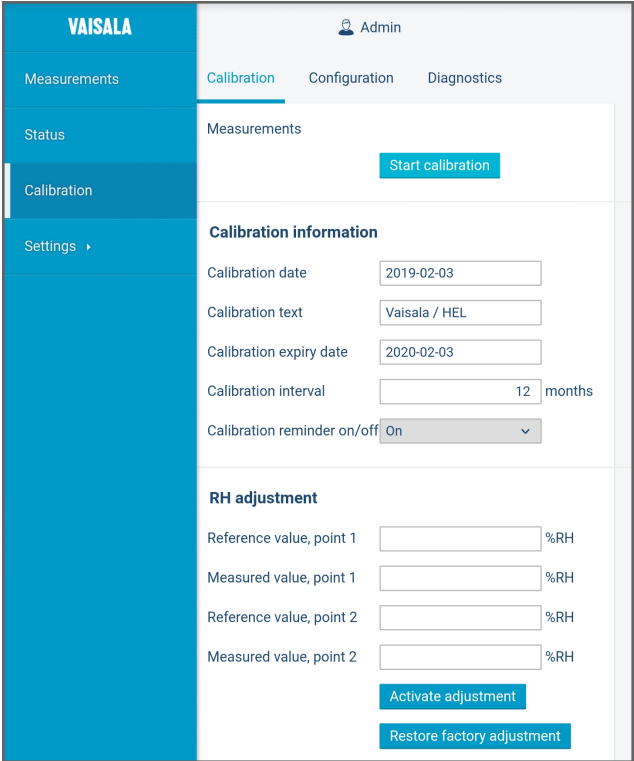

Figure 20 Calibration Page in the Indigo 200 Wireless Configuration Interface

3. To adjust temperature measurement:
  - a. If you did not adjust humidity measurement, select the **Calibration** tab and select **Start calibration** to start the calibration mode.
  - b. In the **T adjustment** section of the page, select **Restore factory adjustment** to remove any existing non-factory adjustments.
  - c. Insert the probe head in the reference environment for T adjustment point 1.
  - d. Wait for temperature measurement to stabilize fully. This may take more than 30 minutes. Monitor the reading to see when the measurement has stabilized.
  - e. Enter the value of the first reference into the **Reference value, point 1** field. Select outside the text box when done. The probe automatically enters the measured value for the adjustment point.
  - f. If you want to adjust temperature measurement in two points, repeat steps [step 3.c](#) ... [step 3.f](#) for T adjustment point 2.
  - g. Select **Activate adjustment** to store the adjustment in the probe.
4. In the **Calibration information** section of the page, update the **Calibration date** and **Calibration text** fields.
5. Select **Stop calibration** to end the calibration mode.

## 7. Troubleshooting

### 7.1 Problem Situations

Table 5 Troubleshooting Table

Problem	Possible Cause	Solution
Measurement output seems incorrect	Installation location is not representative of actual conditions you want to measure	Verify the installation location and relocate the probe if necessary.
	Heat conduction along probe head and cable is interfering with measurement accuracy	Follow the installation recommendations for cases when temperature of measured environment differs greatly from ambient. See <a href="#">Installation (page 13)</a> .
	Probe is in need of adjustment	Calibrate and adjust the probe. See <a href="#">Calibration and Adjustment (page 34)</a> .
Probe status indicator LED is red	Probe is in error state	Connect the probe to Insight software or an Indigo transmitter and read the error message(s). See <a href="#">Vaisala Insight Software (page 24)</a> and <a href="#">Error Messages (page 41)</a> .
Values of measurement parameters stop changing for a few minutes	Probe is performing a sensor heating function such as chemical purge or waiting for the sensor to cool down	Wait for the function to complete and measurement parameters to be available again

### 7.2 Error Messages

The error messages are categorized according to the severity of the status:

- **Critical errors** are fatal to the operation of the device. It may not be able to respond to communication at all, and will not measure correctly.
- **Errors** prevent normal operation of the device. Depending on the problem, errors may resolve themselves. For example, a completely wet humidity sensor may cause a humidity measurement error.
- **Warnings** do not prevent normal operation but may indicate possible problems.
- **Status** indicates a known state of the unit.

Error Message	Description	Recommended Action
<b>Critical Errors</b>		
Firmware checksum mismatch	Firmware is corrupted	Contact Vaisala technical support
Factory default settings corrupted	Parameter memory is corrupted	
Main configuration settings corrupted		
Additional configuration settings corrupted		
Device settings corrupted		
Sensor coefficients corrupted		
Non-volatile memory read write failure	Hardware fault	
<b>Errors</b>		
Temperature measurement error	Readings from sensors missing or out of range	Inspect probe head and sensors visually. If the probe is completely wet, allow it to dry out.  If the sensors are damaged or missing and the error message(s) stay active, contact Vaisala to have the probe repaired.
Humidity measurement error		
Humidity sensor failure		
Capacitance reference error	Hardware fault	Contact Vaisala technical support
Ambient temperature out of range	Probe body too hot or cold	Relocate the probe body so that its ambient temperature is within the specified operating range
Supply voltage out of range	Supply voltage too high or low	Check supply voltage
Sensor heater failure	Hardware fault	Contact Vaisala technical support
<b>Warnings</b>		
Calibration certificate checksum mismatch	Certificate stored in the probe has an invalid checksum	Contact Vaisala technical support
Calibration has expired	Shown by calibration reminder functionality	Calibrate the probe and update the calibration date information
Supply voltage too low for probe heating	Probe heating enabled but supply voltage is too low to use it	Check supply voltage

Error Message	Description	Recommended Action
Software restart	Device has automatically restarted itself	Check that supply voltage is stable and operating environment is within specification
Unexpected device restart		
<b>Status Messages</b>		
Calibration is about to expire	Shown by calibration reminder functionality	Calibrate the probe and update the calibration date information
Purge in progress	Chemical purge of the humidity sensor ongoing	Wait for chemical purge to complete
The readings stay frozen until the sensor cools down	Probe is waiting for its sensors to cool down	Wait for measurement readings to become available

## 8. Technical Data

### 8.1 HMP4 Specifications

Table 6 Measurement Performance

Property	Description/Value
<b>Relative Humidity</b>	
Sensor	HUMICAP R2 Composite
Measurement range	0 ... 100 %RH
Accuracy at +23 °C (+73.4 °F) <sup>1)</sup>	±0.8 %RH (0 ... 90 %RH)
T <sub>63</sub> response time	15 s
<b>Temperature</b>	
Sensor	Pt100 RTD Class F0.1 IEC 60751
Measurement range	-70 ... +180 °C (-94 ... +356 °F)
Accuracy <sup>1) 2)</sup>	±0.1 °C (±0.18 °F)

- 1) Defined against calibration reference
- 2) Exposing temperature sensor to temperatures outside -20 ... +150 °C (-4 ... +302 °F) may cause permanent additional deviation of ±0.1 °C (0.18 °F)

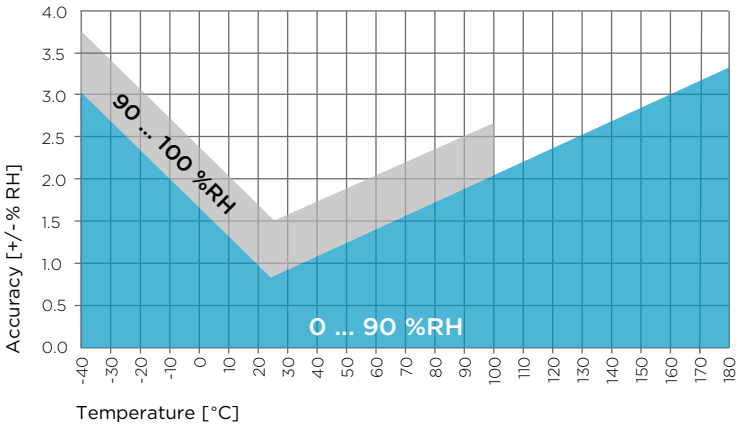

Figure 21 HMP4 Humidity Measurement Accuracy as a Function of Temperature (Including Non-Linearity and Repeatability)

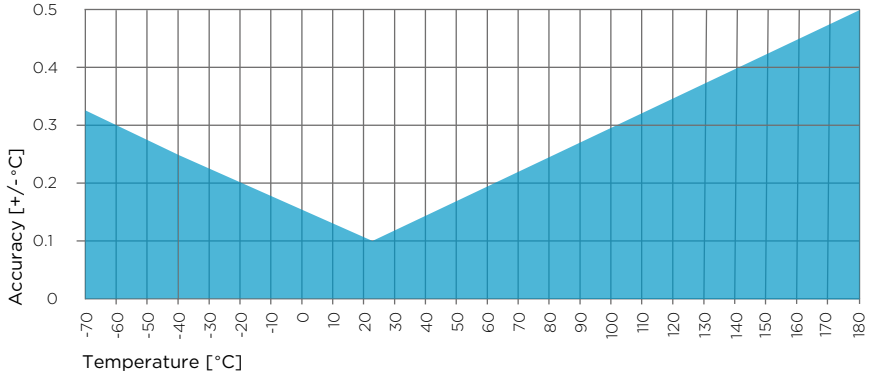

Figure 22 HMP4 Temperature Measurement Accuracy over Full Range (Including Non-Linearity and Repeatability)

Table 7 SI Traceable Calibration

Property	Description/Value
Uncertainty of relative humidity calibration ( $k = 2$ )	$\pm 0.5\%RH$ (0 ... 40 %RH) $\pm 0.8\%RH$ (40 ... 95 %RH)
Uncertainty of temperature calibration ( $k = 2$ )	$\pm 0.1\text{ °C}$ ( $\pm 0.18\text{ °F}$ ) at $+23\text{ °C}$ ( $+73.4\text{ °F}$ )

Table 8 Operating Environment

Property	Description/Value
Operating temperature range for probe body	$-40 \dots +80\text{ °C}$ ( $-40 \dots +176\text{ °F}$ )
Operating temperature range for probe head	$-70 \dots +180\text{ °C}$ ( $-94 \dots +356\text{ °F}$ )
Operating environment	Suitable for outdoor use
IP rating	IP66
Electromagnetic compatibility	EN61326-1, industrial environment
Operational pressure	< 100 bar

Table 9 Inputs and Outputs

Property	Description/Value
Operating voltage	15 ... 30 VDC
Current consumption	10 mA typical, 500 mA max.
Digital output	RS-485, non-isolated

Property	Description/Value
Default serial settings	19200 bps N 8 2
Protocols	Modbus RTU
<b>Output Parameters</b>	
Relative humidity, temperature, dew point temperature, wet-bulb temperature, absolute humidity, mixing ratio, water concentration, water mass fraction, water vapor pressure, enthalpy	

Table 10 Mechanical Specifications

Property	Description/Value
Probe fitting	M22x1.5 and NPT1/2" fittings included
Connector	M12/5
Weight	530 g (18.7 oz)
<b>Materials</b>	
Probe	AISI316
Probe body	AISI316
Cable jacket	FEP

## 8.2 HMP5 Specifications

Table 11 Measurement Performance

Property	Description/Value
<b>Relative Humidity</b>	
Sensor	HUMICAP R2 Composite
Measurement range	0 ... 100 %RH
Accuracy at +23 °C (+73.4 °F) <sup>1)</sup>	±0.8 %RH (0 ... 90 %RH)
T <sub>63</sub> response time	15 s
<b>Temperature</b>	
Sensor	Pt100 RTD Class F0.1 IEC 60751
Measurement range	-70 ... +180 °C (-94 ... +356 °F)



Property	Description/Value
Accuracy at +23 °C (+73.4 °F) <sup>1) 2)</sup>	±0.1 °C (±0.18 °F)

- 1) Defined against calibration reference
- 2) Exposing temperature sensor to temperatures outside -20 ... +150 °C (-4 ... +302 °F) may cause permanent additional deviation of ±0.1 °C (0.18 °F)

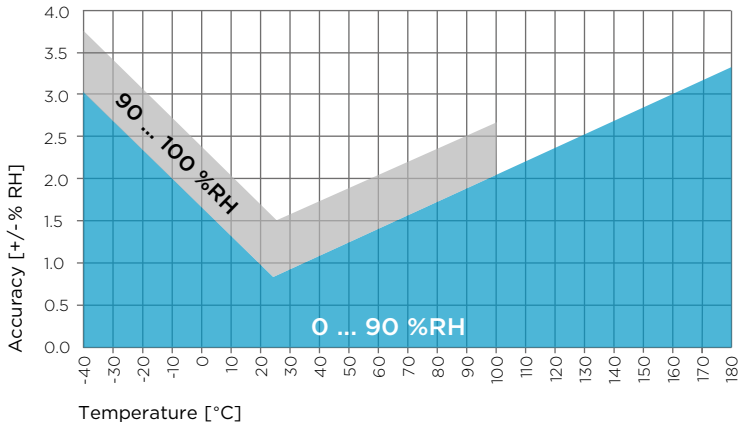

Figure 23 HMP5 Humidity Measurement Accuracy as a Function of Temperature (Including Non-Linearity and Repeatability)

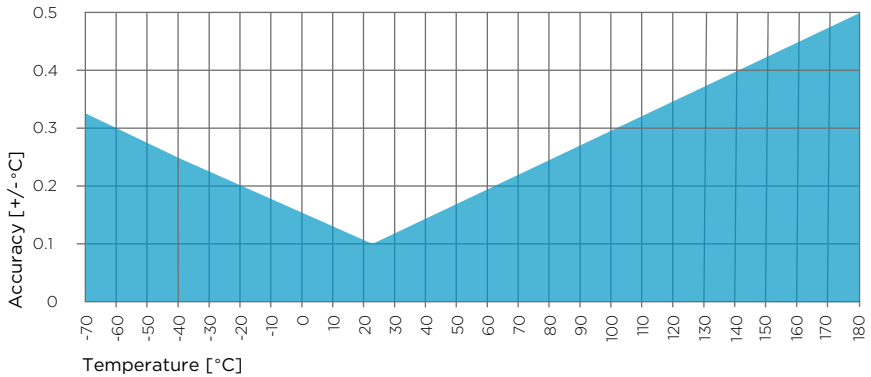

Figure 24 HMP5 Temperature Measurement Accuracy over Full Range (Including Non-Linearity and Repeatability)

Table 12 SI Traceable Calibration

Property	Description/Value
Uncertainty of relative humidity calibration ( $k = 2$ )	$\pm 0.5\%RH$ (0 ... 40 %RH) $\pm 0.8\%RH$ (40 ... 95 %RH)
Uncertainty of temperature calibration ( $k = 2$ )	$\pm 0.1\text{ }^\circ\text{C}$ ( $\pm 0.18\text{ }^\circ\text{F}$ ) at $+23\text{ }^\circ\text{C}$ ( $+73.4\text{ }^\circ\text{F}$ )

Table 13 Operating Environment

Property	Description/Value
Operating temperature range for probe body	$-40 \dots +80\text{ }^\circ\text{C}$ ( $-40 \dots +176\text{ }^\circ\text{F}$ )
Operating temperature range for probe head	$-70 \dots +180\text{ }^\circ\text{C}$ ( $-94 \dots +356\text{ }^\circ\text{F}$ )
Operating environment	Suitable for outdoor use
IP rating	IP66
Electromagnetic compatibility	Complies with EMC standard EN61326-1, Electrical equipment for measurement, control and laboratory use - EMC requirements - Industrial environment

Table 14 Inputs and Outputs

Property	Description/Value
Operating voltage	15 ... 30 VDC
Current consumption	10 mA typical 500 mA max.
Digital output	RS-485, non-isolated
Default serial settings	19200 bps N 8 2
Protocols	Modbus RTU
<b>Output Parameters</b>	
Relative humidity, temperature, dew point temperature, wet-bulb temperature, absolute humidity, mixing ratio, water concentration, water mass fraction, water vapor pressure, enthalpy	

Table 15 Mechanical Specifications

Property	Description/Value
Connector	M12/5
Weight	436 g (15.37 oz)
<b>Materials</b>	

Property	Description/Value
Probe	AISI316L
Probe body	AISI316L
Cable jacket	FEP

## 8.3 HMP7 Specifications

Table 16 Measurement Performance

Property	Description/Value
<b>Relative Humidity</b>	
Sensor	HUMICAP R2 Composite
Measurement range	0 ... 100 %RH
Accuracy at +23 °C (+73.4 °F) <sup>1)</sup>	±0.8 %RH (0 ... 90 %RH)
T <sub>63</sub> response time	15 s
<b>Temperature</b>	
Sensor	Pt100 RTD Class F0.1 IEC 60751
Measurement range	-70 ... +180 °C (-94 ... +356 °F)
Accuracy at +23 °C (+73.4 °F) <sup>1) 2)</sup>	±0.1 °C (±0.18 °F)

1) *Defined against calibration reference*

2) *Exposing temperature sensor to temperatures outside -20 ... +150 °C (-4 ... +302 °F) may cause permanent additional deviation of ±0.1 °C (0.18 °F)*

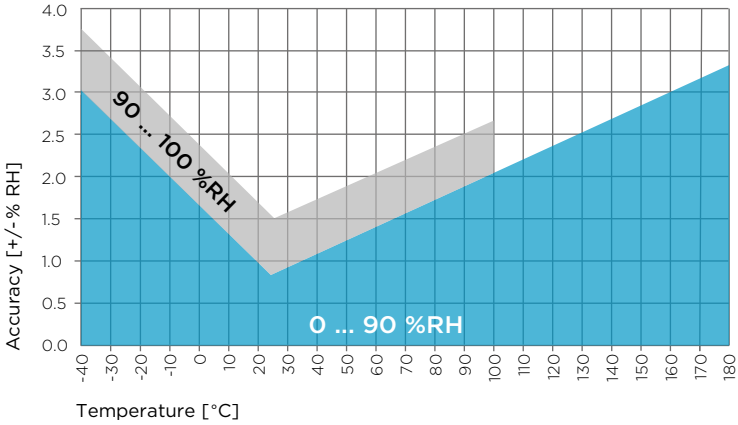

Figure 25 HMP7 Humidity Measurement Accuracy as Function of Temperature (Including Non-Linearity and Repeatability).

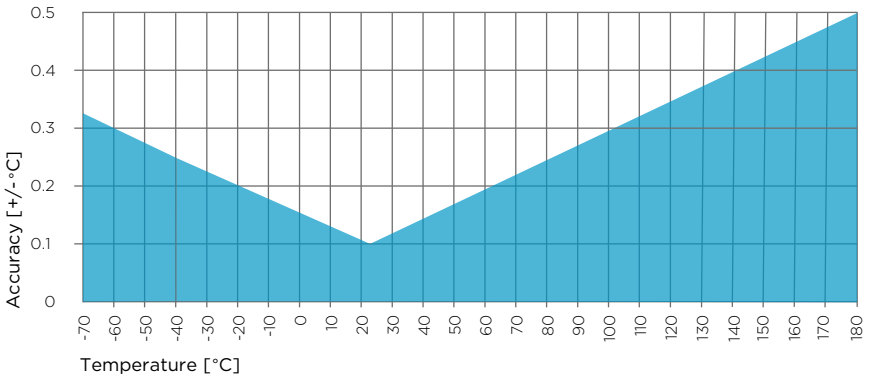

Figure 26 HMP7 Temperature Measurement Accuracy over Full Range (Including Non-Linearity and Repeatability)

Table 17 SI Traceable Calibration

Property	Description/Value
Uncertainty of relative humidity calibration ( $k = 2$ )	$\pm 0.5\%RH$ (0 ... 40 %RH) $\pm 0.8\%RH$ (40 ... 95 %RH)
Uncertainty of temperature calibration ( $k = 2$ )	$\pm 0.1\text{ }^\circ\text{C}$ ( $\pm 0.18\text{ }^\circ\text{F}$ ) at $+23\text{ }^\circ\text{C}$ ( $+73.4\text{ }^\circ\text{F}$ )

Table 18 Operating Environment

Property	Description/Value
Operating temperature range for probe body	-40 ... +80 °C (-40 ... +176 °F)
Operating temperature range for probe head	-70 ... +180 °C (-94 ... +356 °F)
Operating environment	Suitable for outdoor use
IP rating	IP66
Electromagnetic compatibility	EN61326-1, Electrical equipment for measurement, control and laboratory use - EMC requirements - Industrial environment

Table 19 Inputs and Outputs

Property	Description/Value
Operating voltage	18 ... 30 VDC
Current consumption	10 mA typical 500 mA max.
Digital output	RS-485, non-isolated
Default serial settings	19200 bps N 8 2
Protocols	Modbus RTU
<b>Output Parameters</b>	
Relative humidity, temperature, dew point temperature, wet-bulb temperature, absolute humidity, mixing ratio, water concentration, water mass fraction, water vapor pressure, enthalpy	

Table 20 Mechanical Specifications

Property	Description/Value
Connector	M12/5
Weight	310 g (10.9 oz)
<b>Materials</b>	
Probe	AISI316L
Probe body	AISI316L
Cable jacket	FEP

## 8.4 HMP8 Specifications

Table 21 Measurement Performance

Property	Description/Value
<b>Relative Humidity</b>	
Sensor	HUMICAP R2 Composite
Measurement range	0 ... 100 %RH
Accuracy at +23 °C (+73.4 °F) <sup>1)</sup>	±0.8 %RH (0 ... 90 %RH)
T <sub>63</sub> response time	15 s
<b>Temperature</b>	
Sensor	Pt100 RTD Class F0.1 IEC 60751
Measurement range	-70 ... +180 °C (-94 ... +356 °F)
Accuracy at +23 °C (+73.4 °F) <sup>1) 2)</sup>	±0.1 °C (±0.18 °F)

- 1) Defined against calibration reference
- 2) Exposing temperature sensor to temperatures outside -20 ... +150 °C (-4 ... +302 °F) may cause permanent additional deviation of ±0.1 °C (0.18 °F)

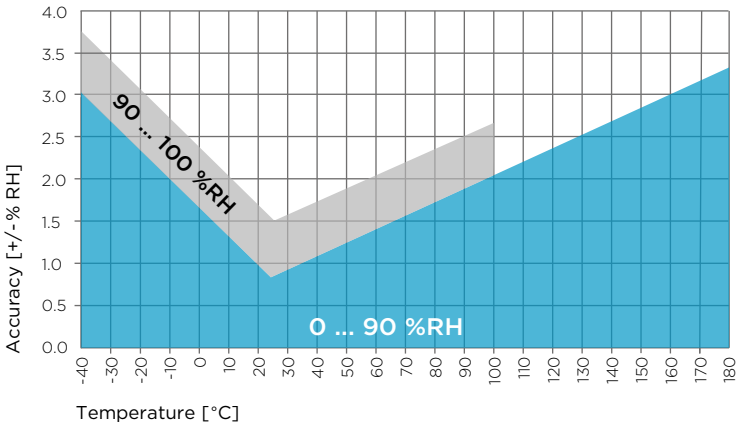

Figure 27 HMP8 Humidity Measurement Accuracy as a Function of Temperature (Including Non-Linearity and Repeatability)

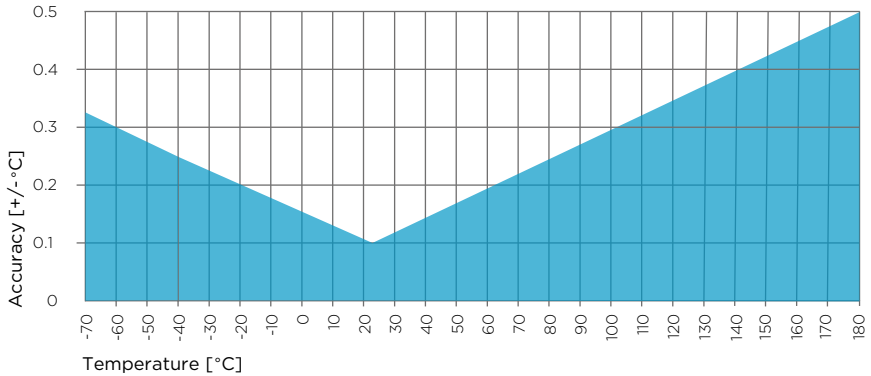

Figure 28 HMP8 Temperature Measurement Accuracy over Full Range (Including Non-Linearity and Repeatability)

Table 22 SI Traceable Calibration

Property	Description/Value
Uncertainty of relative humidity calibration ( $k = 2$ )	$\pm 0.5\%RH$ (0 ... 40 %RH) $\pm 0.8\%RH$ (40 ... 95 %RH)
Uncertainty of temperature calibration ( $k = 2$ )	$\pm 0.1\text{ }^{\circ}\text{C}$ ( $\pm 0.18\text{ }^{\circ}\text{F}$ ) at $+23\text{ }^{\circ}\text{C}$ ( $+73.4\text{ }^{\circ}\text{F}$ )

Table 23 Operating Environment

Property	Description/Value
Operating temperature range for probe body	$-40 \dots +80\text{ }^{\circ}\text{C}$ ( $-40 \dots +176\text{ }^{\circ}\text{F}$ )
Operating temperature range for probe head	$-70 \dots +180\text{ }^{\circ}\text{C}$ ( $-94 \dots +356\text{ }^{\circ}\text{F}$ )
Operating environment	Suitable for outdoor use
IP rating	IP66
Electromagnetic compatibility	Complies with EMC standard EN61326-1, Electrical equipment for measurement, control and laboratory use - EMC requirements - Industrial environment
Operational pressure	< 40 bar

Table 24 Inputs and Outputs

Property	Description/Value
Operating voltage	15 ... 30 VDC

Property	Description/Value
Current consumption	10 mA typical 500 mA max.
Digital output	RS-485, non-isolated
Default serial settings	19200 bps N 8 2
Protocols	Modbus RTU
<b>Output Parameters</b>	
Relative humidity, temperature, dew point temperature, wet-bulb temperature, absolute humidity, mixing ratio, water concentration, water mass fraction, water vapor pressure, enthalpy	

Table 25 Mechanical Specifications

Property	Description/Value
Probe fitting	ISO1/2" and NPT1/2" fittings included
Connector	M12/5
Weight	570 g (20.1 oz)
<b>Materials</b>	
Probe	AISI316L
Probe body	AISI316L
Cable jacket	FEP

## 8.5 HMP9 Specifications

Table 26 Measurement Performance

Property	Description/Value
<b>Relative Humidity</b>	
Sensor	HUMICAP I
Measurement range	0 ... 100 %RH
Non-linearity	0.4 %RH
Accuracy at +23 °C (+73.4 °F) <sup>1) 2)</sup>	±0.8 %RH (0 ... 90 %RH)
T <sub>63</sub> response time <sup>3)</sup>	15 s
<b>Temperature</b>	
Measurement range	-40 ... +120 °C (-40 ... +248 °F)



Property	Description/Value
Accuracy at +23 °C (+73.4 °F) <sup>2)</sup>	±0.1 °C (±0.18 °F)
T <sub>63</sub> response time <sup>3)</sup>	70 s

1) Including non-linearity, hysteresis, and repeatability

2) Defined against calibration reference

3) In still air

Table 27 SI Traceable Calibration

Property	Description/Value
Uncertainty of relative humidity calibration ( $k = 2$ )	±0.5 %RH (0 ... 40 %RH) ±0.8 %RH (40 ... 95 %RH)
Uncertainty of temperature calibration ( $k = 2$ )	±0.1 °C (±0.18 °F) at +23 °C (+73.4 °F)

Table 28 Operating Environment

Property	Description/Value
Operating temperature range for probe body	-40 ... +60 °C (-40 ... +140 °F)
Operating temperature range for probe head	-40 ... +120 °C (-40 ... +248 °F)
Operating environment	Suitable for outdoor use when protected from rain
IP rating	IP65
<b>Electromagnetic Compatibility</b>	
Complies with EMC standard EN61326-1, Electrical equipment for measurement, control and laboratory use - EMC requirements - Industrial environment	

Table 29 Inputs and Outputs

Property	Description/Value
Operating voltage	15 ... 30 VDC
Current consumption	5 mA typical, 400 mA max.
Digital output	RS-485, non-isolated
Default serial settings	19200 bps N 8 2
Protocol	Modbus RTU
<b>Output Parameters</b>	
Relative humidity, temperature, dew point temperature, wet-bulb temperature, absolute humidity, mixing ratio, water concentration, water mass fraction, water vapor pressure, enthalpy	

Table 30 Mechanical Specifications

Property	Description/Value
Connector	M12/5
Weight	68 g (2.40 oz)
Probe cable length	2 m (6.6 ft)
<b>Materials</b>	
Probe	AISI316
Probe body	PBT
Cable overmolds	FEP

## 8.6 TMP1 Specifications

Table 31 Measurement Performance

Property	Description/Value
Sensor	Pt100 RTD Class F0.1 IEC 60751
Measurement range	-70 ... +180 °C (-94 ... +356 °F)
Accuracy at +23 °C (+73.4 °F) <sup>1) 2)</sup>	±0.1 °C (±0.18 °F)

- 1) *Defined against calibration reference*
- 2) *Exposing temperature sensor to temperatures outside -20 ... +150 °C (-4 ... +302 °F) may cause permanent additional deviation of ±0.1 °C (0.18 °F)*

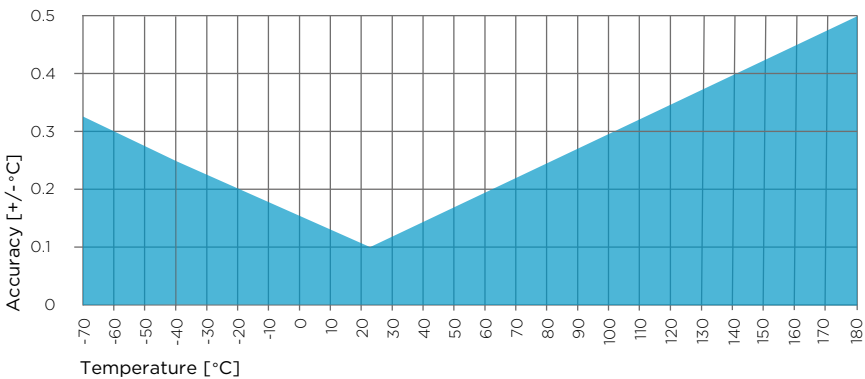

Figure 29 TMP1 Temperature Measurement Accuracy over Full Range (Including Non-Linearity and Repeatability)

Table 32 SI Traceable Calibration

Property	Description/Value
Uncertainty of temperature calibration ( $k = 2$ )	$\pm 0.1$ °C ( $\pm 0.18$ °F) at +23 °C (+73.4 °F)

Table 33 Operating Environment

Property	Description/Value
Operating temperature range for probe body	-40 ... +80 °C (-40 ... +176 °F)
Operating temperature range for probe head	-70 ... +180 °C (-94 ... +356 °F)
Operating environment	Suitable for outdoor use
IP rating	IP66
Electromagnetic compatibility	Complies with EMC standard EN61326-1, Industrial Environment

Table 34 Inputs and Outputs

Property	Description/Value
Operating voltage	15 ... 30 VDC
Current consumption	10 mA typical
Digital output	RS-485, non-isolated
Default serial settings	19200 bps N 8 2
Protocols	Modbus RTU
Output parameters	Temperature, water vapor saturation pressure

Table 35 Mechanical Specifications

Property	Description/Value
Connector	M12/5
Weight	224 g (7.9 oz)
<b>Materials</b>	
Probe	AISI316L
Probe body	AISI316L
Cable jacket	FEP

### 8.7 Dimension Drawings

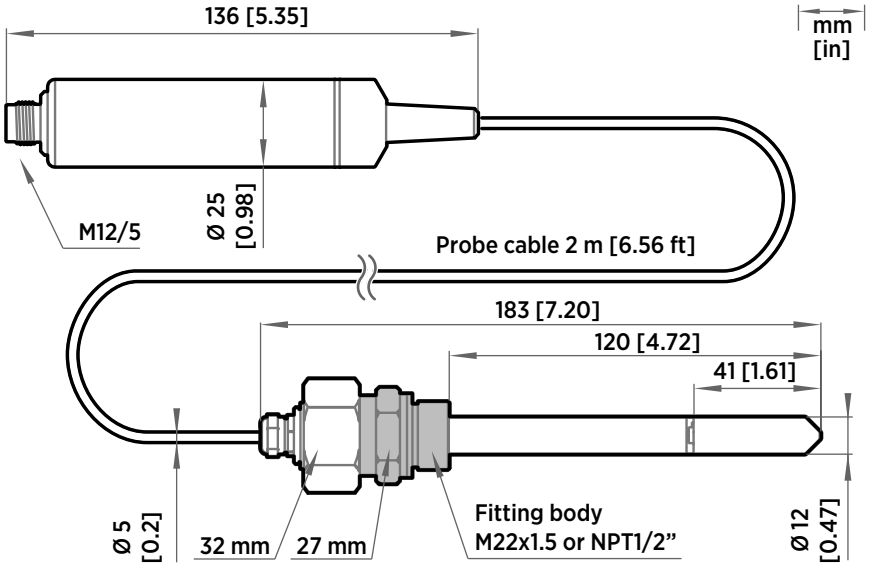

Figure 30 HMP4 Probe Dimensions

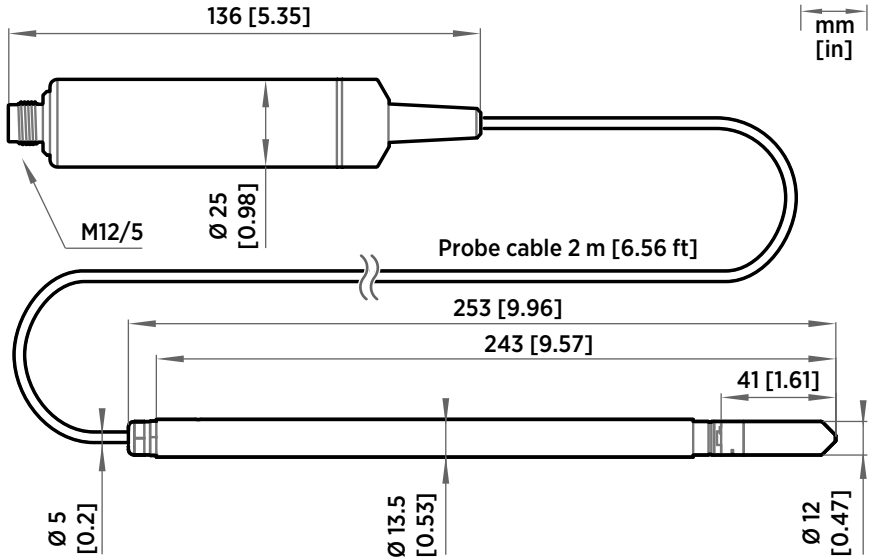

Figure 31 HMP5 Probe Dimensions

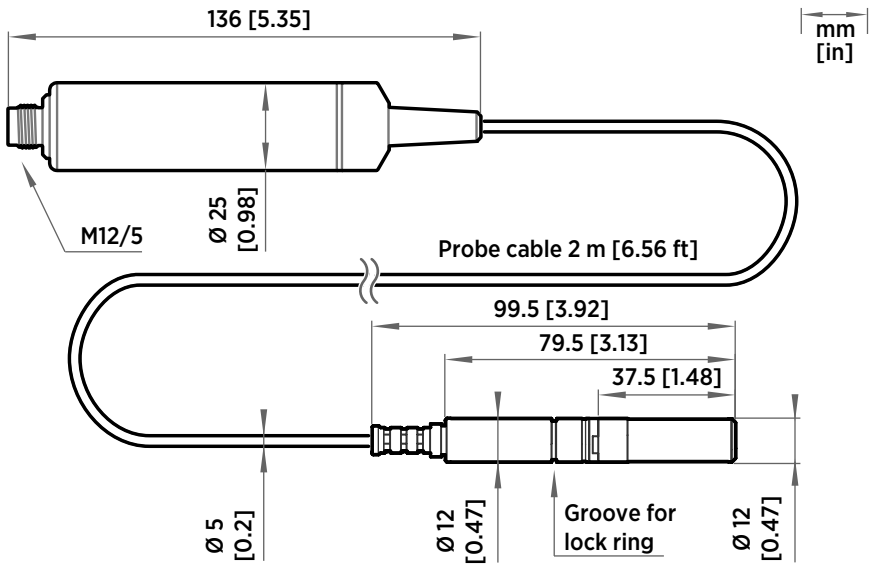

Figure 32 HMP7 Probe Dimensions

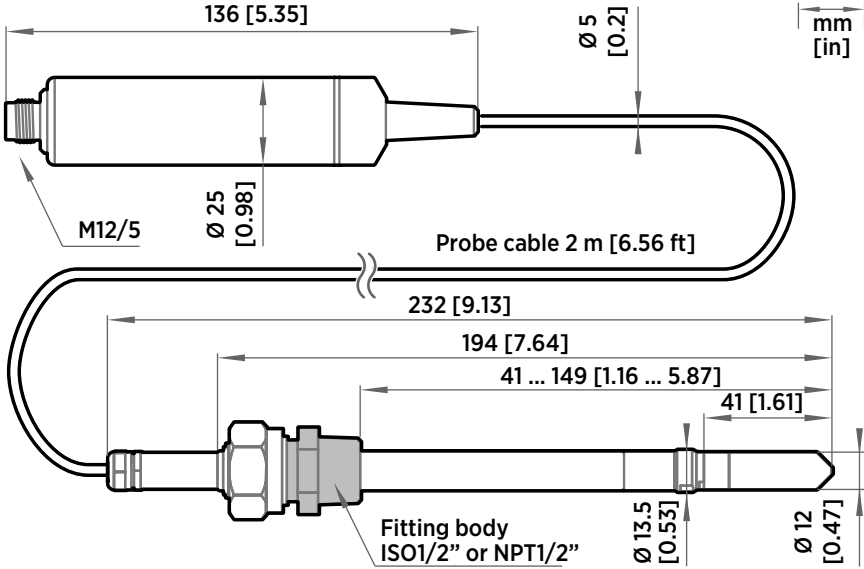

Figure 33 HMP8 Probe Dimensions

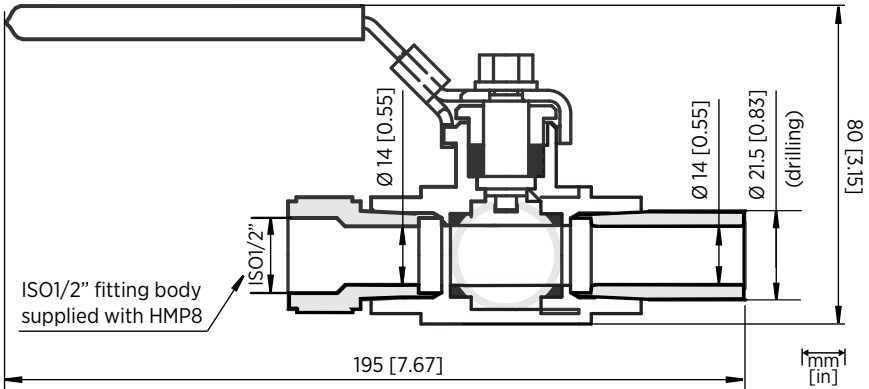

Figure 34 Optional Ball Valve Installation Kit Dimensions

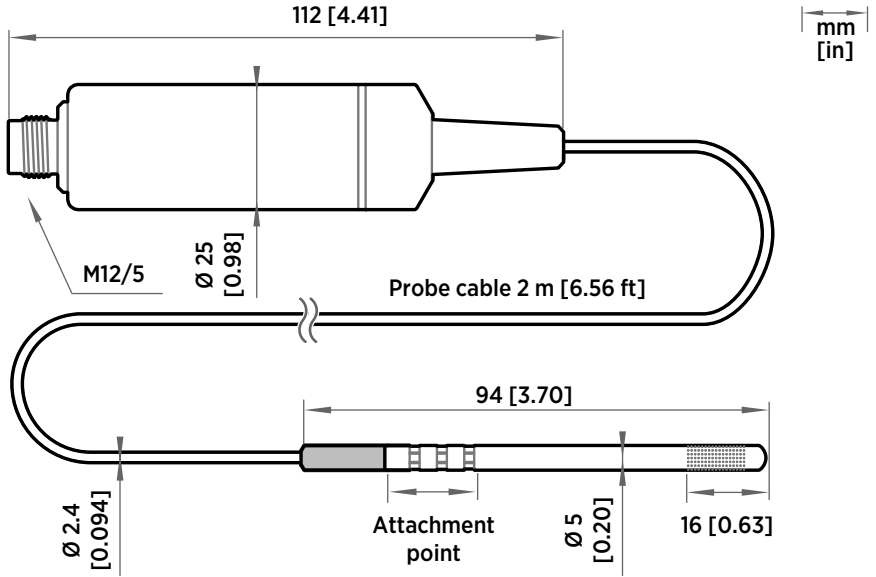

Figure 35 HMP9 Probe Dimensions

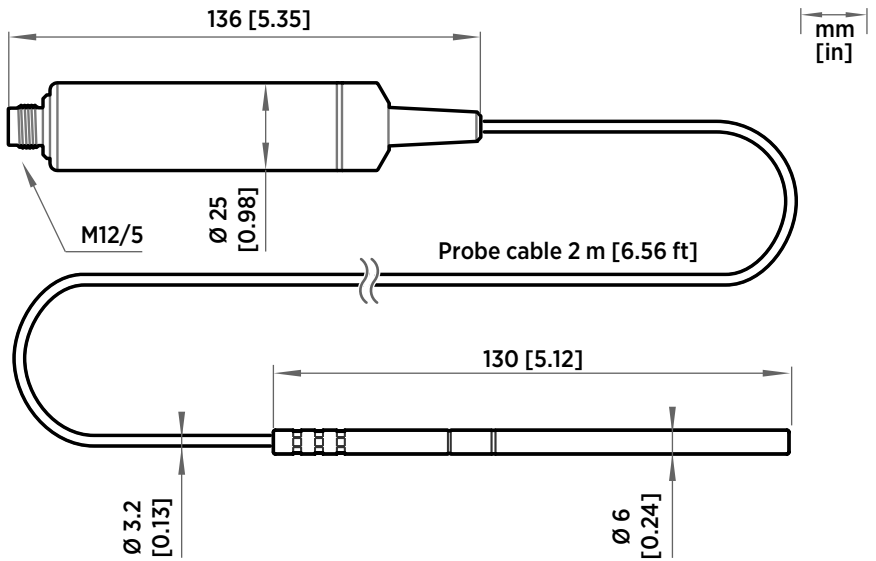

Figure 36 TMP1 Probe Dimensions

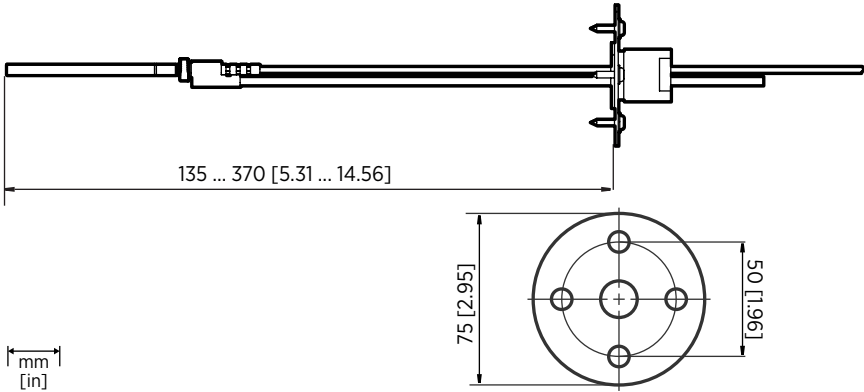

Figure 37 Optional Duct Kit 215003 Dimensions

## 8.8 Spare Parts and Accessories

### HMP4

Table 36 Accessories

Description	Item Code
<b>Transmitters</b>	
Indigo 200 Series	See order form
<b>Connection Cables</b>	
Connection cable to Indigo (1 m)	INDIGOCABLE1M
Connection cable to Indigo (3 m)	INDIGOCABLE3M
Connection cable to Indigo (5 m)	INDIGOCABLE5M
Connection cable to Indigo (10 m)	INDIGOCABLE10M
Open wires 1.5 m	223263SP
Open wires 10 m	216546SP
Open wires and 90° plug	244669SP
Flat cable 1 m M12/5	CBL210493SP
USB PC connection cable <sup>1)</sup>	242659
<b>Filters</b>	
Sintered stainless steel filter <sup>2)</sup>	HM47280SP



Description	Item Code
Stainless steel grid	HM47453SP
Metallized PPS plastic grid with stainless steel mesh filter	DRW010281SP
Metallized PPS plastic grid filter	DRW010276SP

- 1) *Vaisala Insight software for Windows available at [www.vaisala.com/insight](http://www.vaisala.com/insight)*
- 2) *Standard in delivery*

## HMP5

Table 37 Accessories

Description	Item Code
<b>Transmitters</b>	
Indigo 200 Series	See order form
<b>Connection Cables</b>	
Connection cable to Indigo (1 m)	INDIGOCABLE1M
Connection cable to Indigo (3 m)	INDIGOCABLE3M
Connection cable to Indigo (5 m)	INDIGOCABLE5M
Connection cable to Indigo (10 m)	INDIGOCABLE10M
Open wires 1.5 m	223263SP
Open wires 10 m	216546SP
Open wires and 90° plug	244669SP
Flat cable 1 m M12/5	CBL210493SP
USB PC connection cable <sup>1)</sup>	242659
<b>Filters</b>	
Sintered stainless steel filter <sup>2)</sup>	HM47280SP
Stainless steel grid	HM47453SP
Metallized PPS plastic grid with stainless steel mesh filter	DRW010281SP
Metallized PPS plastic grid filter	DRW010276SP
<b>Accessories</b>	

Description	Item Code
Mounting flange	210696

- 1) *Vaisala Insight software for Windows available at [www.vaisala.com/insight](http://www.vaisala.com/insight)*
- 2) *Standard in delivery*

## HMP7

Table 38 Accessories

Description	Item Code
<b>Transmitters</b>	
Indigo 200	See order form
<b>Connection Cables</b>	
Connection cable to Indigo (1 m)	INDIGOCABLE1M
Connection cable to Indigo (3 m)	INDIGOCABLE3M
Connection cable to Indigo (5 m)	INDIGOCABLE5M
Connection cable to Indigo (10 m)	INDIGOCABLE10M
Open wires 1.5 m	223263SP
Open wires 10 m	216546SP
Open wires and 90° plug	244669SP
Flat cable 1 m M12/5	CBL210493SP
USB PC connection cable <sup>1)</sup>	242659
<b>Filters</b>	
Sintered stainless steel filter	HM47280SP
Stainless steel grid	HM47453SP
Metallized PPS plastic grid with stainless steel mesh filter <sup>2)</sup>	DRW010281SP
Metallized PPS plastic grid filter	DRW010276SP
<b>Accessories</b>	
Duct installation kit for RH probe	210697
Solar radiation shield	DTR502B
Cable gland M20x1.5 with split seal	HMP247CG
Swagelok for 12 mm probe, 1/2" ISO thread	SWG12ISO12
Swagelok for 12 mm probe, 3/8" ISO thread	SWG12ISO38

Description	Item Code
Swagelok for 12 mm probe, 1/2" NPT thread	SWG12NPT12

- 1) *Vaisala Insight software for Windows available at [www.vaisala.com/insight](http://www.vaisala.com/insight)*
- 2) *Standard in delivery*

## HMP8

Table 39 Accessories

Description	Item Code
<b>Transmitters</b>	
Indigo 200 Series	See order form
<b>Connection Cables</b>	
Connection cable to Indigo (1 m)	INDIGOCABLE1M
Connection cable to Indigo (3 m)	INDIGOCABLE3M
Connection cable to Indigo (5 m)	INDIGOCABLE5M
Connection cable to Indigo (10 m)	INDIGOCABLE10M
Open wires 1.5 m	223263SP
Open wires 10 m	216546SP
Open wires and 90° plug	244669SP
Flat cable 1 m M12/5	CBL210493SP
USB PC connection cable <sup>1)</sup>	242659
<b>Filters</b>	
Sintered stainless steel filter <sup>2)</sup>	HM47280SP
Stainless steel grid	HM47453SP
Metallized PPS plastic grid with stainless steel mesh filter	DRW010281SP
Metallized PPS plastic grid filter	DRW010276SP
<b>Accessories</b>	
Ball valve 1/2" with ISO 1/2" welding joint	BALLVALVE-1

- 1) *Vaisala Insight software for Windows available at [www.vaisala.com/insight](http://www.vaisala.com/insight)*
- 2) *Standard in delivery*

## HMP9

Table 40 Accessories

Description	Item Code
<b>Transmitters</b>	
Indigo 200 Series	See order form
<b>Connection Cables</b>	
Connection cable to Indigo (1 m)	INDIGOCABLE1M
Connection cable to Indigo (3 m)	INDIGOCABLE3M
Connection cable to Indigo (5 m)	INDIGOCABLE5M
Connection cable to Indigo (10 m)	INDIGOCABLE10M
Open wires 1.5 m	223263SP
Open wires 10 m	216546SP
Open wires and 90° plug	244669SP
Flat cable 1 m M12/5	CBL210493SP
USB PC connection cable <sup>1)</sup>	242659

1) Vaisala Insight software for Windows available at [www.vaisala.com/insight](http://www.vaisala.com/insight)

## TMP1

Table 41 Accessories

Description	Item Code
<b>Transmitters</b>	
Indigo 200 Series	See order form
<b>Connection Cables</b>	
Connection cable to Indigo (1 m)	INDIGOCABLE1M
Connection cable to Indigo (3 m)	INDIGOCABLE3M
Connection cable to Indigo (5 m)	INDIGOCABLE5M
Connection cable to Indigo (10 m)	INDIGOCABLE10M
Open wires 1.5 m	223263SP
Open wires 10 m	216546SP
Open wires and 90° plug	244669SP

Description	Item Code
Flat cable 1 m M12/5	CBL210493SP
USB PC connection cable <sup>1)</sup>	242659
<b>Accessories</b>	
Duct installation kit for T probe	215003
Swagelok for 6 mm probe 1/8" ISO thread	SWG6ISO18
Swagelok for 6 mm probe 1/8" NPT thread	SWG6NPT18

1) *Vaisala Insight software for Windows available at [www.vaisala.com/insight](http://www.vaisala.com/insight)*

# Appendix A. Modbus Reference

## A.1 Default Communication Settings

Table 42 Default Modbus Serial Communication Settings

Property	Description/Value
Serial bit rate	19200
Parity	None
Number of data bits	8
Number of stop bits	2
Flow control	None
Modbus device address	240

You can use up to ten probes on the same RS-485 line. You must configure each probe on the line to have a different Modbus address.

## A.2 Function Codes

Table 43 Modbus Function Codes

Function Code (Decimal)	Function Code (Hexadecimal)	Name	Notes
03	03 <sub>hex</sub>	Read Holding Registers	Class 0
16	10 <sub>hex</sub>	Write Multiple Registers	Class 0
43 / 14	2B <sub>hex</sub> / 0E <sub>hex</sub>	Read Device Identification	

## A.3 Data Encoding

In the data registers, the numeric values are available in one or two formats with separate register addresses: 32-bit IEEE floating point format and/or 16-bit signed integer format.

### A.3.1 32-Bit Floating Point or Integer Format

Least significant 16 bits of floating point or integer numbers are placed at the smaller Modbus address as specified in Open Modbus TCP Specification, Release 1.0. This is also known as "little-endian" or "Modicon" word order. Floating point values are represented in standard IEEE 32-bit floating point format.



Despite the specification, some Modbus masters may expect "big-endian" word order (most significant word first). In such case, you must select "word-swapped" floating point format in your Modbus master for the Modbus registers of the device.

A "quiet NaN" value is returned for unavailable values. A quiet NaN is, for example, 7FC00000<sub>hex</sub>; however, the master should understand any NaN value.



A complete 32-bit floating point or integer value should be read and written in a single Modbus transaction.

### A.3.2 16-Bit Integer Format

Some 16-bit integer values in the data registers are scaled to include the necessary decimals. The scaling factors for those values are shown in the register tables.

Table 44 16-bit Signed Integer Format Details

Value	Description
0000 <sub>hex</sub> ... 7FFE <sub>hex</sub>	Value in range 0 ... 32766
8002 <sub>hex</sub> ... FFFF <sub>hex</sub>	Value in range -32766 ... -1 (2's complement)
8000 <sub>hex</sub>	Value is not available (quiet NaN)



Some values may exceed the signed 16-bit range even in normal operation. To access such values, use the floating point registers instead.

## A.4 Modbus Registers



**CAUTION!** Registers are numbered in decimal, starting from one. Register addresses in actual Modbus messages (Modbus Protocol Data Unit (PDU) are in hexadecimal and start from zero. Subtract 1 from the register number presented in this manual to get the address used in the Modbus message (for example, register number 1 corresponds to address 0<sub>hex</sub> in the actual Modbus message).

Accessing unavailable (temporarily missing) measurement data does not generate an exception. “Unavailable” value (a quiet NaN for floating point data or 8000<sub>hex</sub> for integer data) is returned instead. An exception is generated only for any access outside the applicable register ranges.

## A.4.1 Measurement Data Registers

Table 45 Floating Point Measurement Data Registers (Read-Only)

Register Number (Decimal)	Address (Hexadecimal)	Register Description	Data Format	Metric Unit
1	0000 <sub>hex</sub>	Relative humidity	32-bit float	%RH
	0001 <sub>hex</sub>			
3	0002 <sub>hex</sub>	Temperature	32-bit float	°C
	0003 <sub>hex</sub>			
7	0006 <sub>hex</sub>	Dew point temperature	32-bit float	°C
	0007 <sub>hex</sub>			
9	0008 <sub>hex</sub>	Dew/frost point temperature	32-bit float	°C
	0009 <sub>hex</sub>			
11	000A <sub>hex</sub>	Dew/frost point temperature at 1 atm	32-bit float	°C
	000B <sub>hex</sub>			
13	000C <sub>hex</sub>	Dew point temperature at 1 atm	32-bit float	°C
	000D <sub>hex</sub>			
15	000E <sub>hex</sub>	Absolute humidity	32-bit float	g/m <sup>3</sup>
	000F <sub>hex</sub>			
17	0010 <sub>hex</sub>	Mixing ratio	32-bit float	g/kg
	0011 <sub>hex</sub>			
19	0012 <sub>hex</sub>	Wet-bulb temperature	32-bit float	°C
	0013 <sub>hex</sub>			
21	0014 <sub>hex</sub>	Water concentration	32-bit float	ppm <sub>v</sub>
	0015 <sub>hex</sub>			
23	0016 <sub>hex</sub>	Water vapor pressure	32-bit float	hPa
	0017 <sub>hex</sub>			



Register Number (Decimal)	Address (Hexadecimal)	Register Description	Data Format	Metric Unit
25	0018 <sub>hex</sub>	Water vapor saturation pressure	32-bit float	hPa
	0019 <sub>hex</sub>			
27	001A <sub>hex</sub>	Enthalpy	32-bit float	kJ/kg
	001B <sub>hex</sub>			
31	001E <sub>hex</sub>	Dew point temperature difference	32-bit float	°C
	001F <sub>hex</sub>			
33	0020 <sub>hex</sub>	Absolute humidity at NTP	32-bit float	g/m <sup>3</sup>
	0021 <sub>hex</sub>			
65	0040 <sub>hex</sub>	Water mass fraction	32-bit float	ppm <sub>w</sub>
	0041 <sub>hex</sub>			

Table 46 Integer Measurement Data Registers (Read-Only)

Register Number (Decimal)	Address (Hexadecimal)	Register Description	Data Format	Scale Factor	Offset	Metric Unit
257	0100 <sub>hex</sub>	Relative humidity	16-bit signed integer	100	0	%RH
258	0101 <sub>hex</sub>	Temperature	16-bit signed integer	100	0	°C
260	0103 <sub>hex</sub>	Dew point temperature	16-bit signed integer	100	0	°C
261	0104 <sub>hex</sub>	Dew/frost point temperature	16-bit signed integer	100	0	°C
262	0105 <sub>hex</sub>	Dew/frost point temperature at 1 atm	16-bit signed integer	100	0	°C
263	0106 <sub>hex</sub>	Dew point temperature at 1 atm	16-bit signed integer	100	0	°C
264	0107 <sub>hex</sub>	Absolute humidity	16-bit signed integer	100	0	g/m <sup>3</sup>
265	0108 <sub>hex</sub>	Mixing ratio	16-bit signed integer	100	0	g/kg

Register Number (Decimal)	Address (Hexadecimal)	Register Description	Data Format	Scale Factor	Offset	Metric Unit
266	0109 <sub>hex</sub>	Wet-bulb temperature	16-bit signed integer	100	0	°C *
267	010A <sub>hex</sub>	Water concentration	16-bit signed integer	1	0	ppm <sub>v</sub>
268	010B <sub>hex</sub>	Water vapor pressure	16-bit signed integer	10	0	hPa
269	010C <sub>hex</sub>	Water vapor saturation pressure	16-bit signed integer	10	0	hPa
270	010D <sub>hex</sub>	Enthalpy	16-bit signed integer	100	0	kJ/kg
272	010F <sub>hex</sub>	Dew point temperature difference	16-bit signed integer	10	0	°C
273	0110 <sub>hex</sub>	Absolute humidity at NTP	16-bit signed integer	100	0	g/m <sup>3</sup>
289	0120 <sub>hex</sub>	Water vapor mass fraction	16-bit signed integer	1	0	ppm <sub>w</sub>

### A.4.2 Configuration Registers

Table 47 Modbus Configuration Data Registers (Writable)

Register Number (Decimal)	Register Address (Hexadecimal)	Register Description	Data Format	Unit / Valid Range
<b>General</b>				
1287	0506 <sub>hex</sub>	Extra heat on/off. Enables heating of humidity sensor when close to saturation. Measurement is disabled for the duration of heating and cooling.	16-bit boolean	0 = off (default) 1 = on

Register Number (Decimal)	Register Address (Hexadecimal)	Register Description	Data Format	Unit / Valid Range
<b>General</b>				
1289	0508 <sub>hex</sub>	Probe heating on/off. Available on HMP7 model only.  When on, output parameters that depend on temperature measurement (for example, relative humidity) are disabled unless temperature is written to register 0334 <sub>hex</sub> from an external source.	16-bit boolean	0 = off (default) 1 = on
2561	0A00 <sub>hex</sub>	User information	Text	Text string of 24 bytes in UTF-8 encoding
<b>Compensation Setpoints</b>				
769	0300 <sub>hex</sub>	Pressure compensation setpoint	32-bit float	Unit: hPA Default: 1013.25 hPa
	0301 <sub>hex</sub>			
821	0334 <sub>hex</sub>	Temperature compensation setpoint. If a value is written to this register, probe uses it instead of its own temperature measurement.  When probe heating is in use, temperature must be written to this register to enable output parameters that depend on temperature measurement (for example, relative humidity).	32-bit float	Unit: °C
	0335 <sub>hex</sub>			
<b>Purge</b>				
773	0304 <sub>hex</sub>	Purge interval	32-bit float	Unit: min 10 ... 14400
	0305 <sub>hex</sub>			
1283	0502 <sub>hex</sub>	Interval purge on/off	16-bit boolean	0 = Off 1 = On

<b>Purge</b>				
1284	0503 <sub>hex</sub>	Startup purge on/off	16-bit boolean	0 = Off 1 = On
<b>Filtering</b>				
795	031A <sub>hex</sub>	Measurement filtering factor	32-bit float	Range: 0.000 ... 1.000 1.000 = Reading shows 100% of the most recent measured value (no filtering, default) 0.01 ... 0.99 = Reading shows 1 ... 99% of the most recent measured value and part of the previous reading (filtering is applied). For example, "0.9" means that the filtered measurement reading = 90% of the most recent measured value + 10% of the previous reading.
	031B <sub>hex</sub>			
1282	0501 <sub>hex</sub>	Enable of disable measurement filtering using the user-defined filtering factor (register 031A <sub>hex</sub> )	16-bit boolean	0 = Off 1 = On
<b>Communication</b>				
1537	0600 <sub>hex</sub>	Modbus address	16-bit integer	1 ... 247 Default: 240
1538	0601 <sub>hex</sub>	Bit rate	enum	0 = 300 1 = 600 2 = 1200 3 = 2400 4 = 4800 5 = 9600 6 = 19200 7 = 38400 8 = 57600 9 = 115200

Communication				
1539	0602 <sub>hex</sub>	Parity, data, stop bits	enum	0 = None, 8, 1 1 = None, 8, 2 2 = Even, 8, 1 3 = Even, 8, 2 4 = Odd, 8, 1 5 = Odd, 8, 2 (default: 1 = None, 8, 2)
1540	0603 <sub>hex</sub>	Response delay	16-bit integer	Unit: ms Range: 0 ... 1000
Functions				
1285	0504 <sub>hex</sub>	Start purge	16-bit function status	When writing to register: 1 = Start purge
1542	0605 <sub>hex</sub>	Restart device	16-bit function status	When writing to register: 1 = Restart the device

### A.4.3 Device Identification Objects

Table 48 Device Identification Objects

Object Id (Decimal)	Object Id (Hexadecimal)	Object Name	Example Contents
0	00 <sub>hex</sub>	VendorName	"Vaisala"
1	01 <sub>hex</sub>	ProductCode	"HMP4"
2	02 <sub>hex</sub>	MajorMinorVersion	Software version (for example "1.2.3")
3	03 <sub>hex</sub>	VendorUrl	"http://www.vaisala.com/"
4	04 <sub>hex</sub>	ProductName	"Humidity and Temperature Probe HMP4"
5	05 <sub>hex</sub>	ModelName	Configuration code
6	06 <sub>hex</sub>	UserApplicationName	User definable information text (see configuration register 0A00 <sub>hex</sub> )
128	80 <sub>hex</sub>	SerialNumber <sup>1)</sup>	Serial number of the device (for example "K0710040")

Object Id (Decimal)	Object Id (Hexadecimal)	Object Name	Example Contents
129	81 <sub>hex</sub>	CalibrationDate <sup>1)</sup>	Calibration date
130	82 <sub>hex</sub>	CalibrationText <sup>1)</sup>	Calibration information text

1) *Vaisala-specific device identification object.*

### A.4.4 Status Registers

Table 49 Modbus Status Data Registers (Read-Only)

Register Number (Decimal)	Address (Hexadecimal)	Register Description	Data Format	Note
513	0200 <sub>hex</sub>	Error status	16-bit boolean	<b>0000</b> <sub>hex</sub> : One or more errors active <b>0001</b> <sub>hex</sub> : No errors
514	0201 <sub>hex</sub>	Online status	16-bit boolean	<b>0000</b> <sub>hex</sub> : Output locked <b>0001</b> <sub>hex</sub> : Online data available
516	0203 <sub>hex</sub>	Error code	32-bit signed integer	See <a href="#">Table 50 (page 77)</a> .
	0204 <sub>hex</sub>			
518	0205 <sub>hex</sub>	Security hash	32-bit signed integer	Security hash changes when any change is made to device settings or adjustments.
	0206 <sub>hex</sub>			
520	0207 <sub>hex</sub>	RH measurement status	16-bit signed integer	<b>0000</b> <sub>hex</sub> : Status OK <b>0002</b> <sub>hex</sub> : Reading is not reliable
521	0208 <sub>hex</sub>	T measurement status	16-bit signed integer	<b>0004</b> <sub>hex</sub> : Under range <b>0008</b> <sub>hex</sub> : Over range
522	0209 <sub>hex</sub>	Tdf measurement status	16-bit signed integer	<b>0020</b> <sub>hex</sub> : Value locked <b>0040</b> <sub>hex</sub> : Calibration expired <b>0080</b> <sub>hex</sub> : Sensor failure <b>0100</b> <sub>hex</sub> : Measurement not ready

Register Number (Decimal)	Address (Hexadecimal)	Register Description	Data Format	Note
523	020A <sub>hex</sub>	Device status	16-bit signed integer	<b>0000<sub>hex</sub></b> : Status OK <b>0001<sub>hex</sub></b> : Critical error, maintenance needed <b>0002<sub>hex</sub></b> : Error, device may recover automatically <b>0004<sub>hex</sub></b> : Warning <b>0008<sub>hex</sub></b> : Notification <b>0010<sub>hex</sub></b> : Calibration mode active

Table 50 Error Codes in Register 0203<sub>hex</sub>

Bitmask	Error Message	Severity
0000 <sub>hex</sub>	Status OK	
0001 <sub>hex</sub>	Temperature measurement error	Error
0002 <sub>hex</sub>	Humidity measurement error	Error
0004 <sub>hex</sub>	Humidity sensor failure	Error
0008 <sub>hex</sub>	Capacitance reference error	Error
0010 <sub>hex</sub>	Ambient temperature out of range	Error
800000 <sub>hex</sub>	Sensor heater failure	Warning

### A.4.5 Test Value Registers

Read the known test values from the test registers to verify the functionality of your Modbus implementation.

Table 51 Modbus Test Registers (Read-Only)

Register Number (Decimal)	Register Address (Hexadecimal)	Register Description	Data Format	Test value
7937	1F00 <sub>hex</sub>	Signed integer test	16-bit integer	-12345
7938	1F01 <sub>hex</sub>	Floating point test	32-bit float	-123.45
	1F02 <sub>hex</sub>			

Register Number (Decimal)	Register Address (Hexadecimal)	Register Description	Data Format	Test value
7940	1F03 <sub>hex</sub>	Text string test	text	Text string "-123.45"
	1F04 <sub>hex</sub>			
	1F05 <sub>hex</sub>			
	1F06 <sub>hex</sub>			

### A.4.6 Modbus Communication Examples

#### Reading Relative Humidity Value



Device address used in the following examples is 240 (F0<sub>hex</sub>).  
 The values returned by the device differ depending on the ambient conditions and/or device settings. Your device might not return exactly same values.

Request		Response	
Bytes on the Line (Hexadecimal)	Description	Bytes on the Line (Hexadecimal)	Description
(silence for 3.5 bytes)	Start of Modbus RTU frame	(silence for 3.5 bytes)	Start of Modbus RTU frame
F0 <sub>hex</sub>	Probe address	F0 <sub>hex</sub>	Probe address
03 <sub>hex</sub>	Function (Read Holding Registers)	03 <sub>hex</sub>	Function (Read Holding Registers)
00 <sub>hex</sub>	Register address	04 <sub>hex</sub>	Number of data bytes
00 <sub>hex</sub>		7A <sub>hex</sub>	Value of first register (least significant word)
00 <sub>hex</sub>	Number of 16-bit registers to read (2)	E1 <sub>hex</sub>	Value of second register (most significant word)
02 <sub>hex</sub>		41 <sub>hex</sub>	
D1 <sub>hex</sub>	Modbus RTU checksum	F4 <sub>hex</sub>	Modbus RTU checksum
2A <sub>hex</sub>		05 <sub>hex</sub>	
(silence for 3.5 bytes)	End of Modbus RTU frame	06 <sub>hex</sub>	End of Modbus RTU frame
		(silence for 3.5 bytes)	



Communication Description	
Register address	1 (1-based Modbus documentation format) = 0000 <sub>hex</sub> (0-based format used in actual communication).
Data format	Two 16-bit Modbus registers interpreted as IEEE 754 binary32 floating point value, least significant word first.
Returned value	41F47AE1 <sub>hex</sub> , which is binary32 representation of 30.56 (%RH).

### Writing Pressure Compensation Value

Request		Response	
Bytes on the Line (Hexadecimal)	Description	Bytes on the Line (Hexadecimal)	Description
(silence for 3.5 bytes)	Start of Modbus RTU frame	(silence for 3.5 bytes)	Start of Modbus RTU frame
F0 <sub>hex</sub>	Probe address	F0 <sub>hex</sub>	Probe address
10 <sub>hex</sub>	Function (Write Multiple Registers)	10 <sub>hex</sub>	Function (Write Multiple Registers)
03 <sub>hex</sub>	Register address	03 <sub>hex</sub>	Register address
00 <sub>hex</sub>			
00 <sub>hex</sub>	Number of registers to write (2)	00 <sub>hex</sub>	Number of 16-bit registers written (2)
02 <sub>hex</sub>			
04 <sub>hex</sub>	Number of data bytes	AD <sub>hex</sub>	Modbus RTU checksum
6E <sub>hex</sub>	Value for first register (least significant word)	54 <sub>hex</sub>	
14 <sub>hex</sub>			
44 <sub>hex</sub>	Value for second register (least significant word)	(silence for 3.5 bytes)	End of Modbus RTU frame
75 <sub>hex</sub>			
AB <sub>hex</sub>	Modbus RTU checksum	<div style="background-color: #e0e0e0; padding: 10px;">  <p>The response to a write function informs that the function was correctly received by the device. It does not guarantee that the written value was accepted by the device (for example, in case out-of-range values).  To verify that the value was really accepted by the device, read the register value after writing.</p> </div>	
4E <sub>hex</sub>			
(silence for 3.5 bytes)	End of Modbus RTU frame		

Communication Description	
Register address	769 (1-based Modbus documentation format) = 0300 <sub>hex</sub> (0-based format used in actual communication).

Communication Description	
Data format	Two 16-bit Modbus registers interpreted as IEEE 754 binary32 floating point value, least significant word first.
Value to write	44756E14 <sub>hex</sub> = 981.72 (hPa)



## Online Store

Spare parts, accessories, and calibration and repair products are available online at [store.vaisala.com](https://store.vaisala.com).

## Warranty

For standard warranty terms and conditions, see [www.vaisala.com/warranty](https://www.vaisala.com/warranty).

Please observe that any such warranty may not be valid in case of damage due to normal wear and tear, exceptional operating conditions, negligent handling or installation, or unauthorized modifications. Please see the applicable supply contract or Conditions of Sale for details of the warranty for each product.

## Technical Support



Contact Vaisala technical support at [helpdesk@vaisala.com](mailto:helpdesk@vaisala.com). Provide at least the following supporting information:

- Product name, model, and serial number
- Name and location of the installation site
- Name and contact information of a technical person who can provide further information on the problem

For more information, see [www.vaisala.com/support](https://www.vaisala.com/support).

## Recycling



Recycle all applicable material.



Follow the statutory regulations for disposing of the product and packaging.





**VAISALA**

[www.vaisala.com](http://www.vaisala.com)

