

# MODEL - BVL

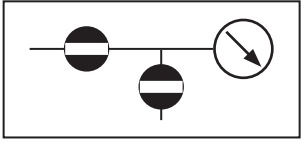

## BLOCK AND BLEED VALVE MANIFOLD

413 bar (6000 psi)



### APPLICATION

Block and bleed of instruments

Also available in a range of other materials and options  
(See HOW TO ORDER Data Sheet).



WEIGHT = 1.7 kg

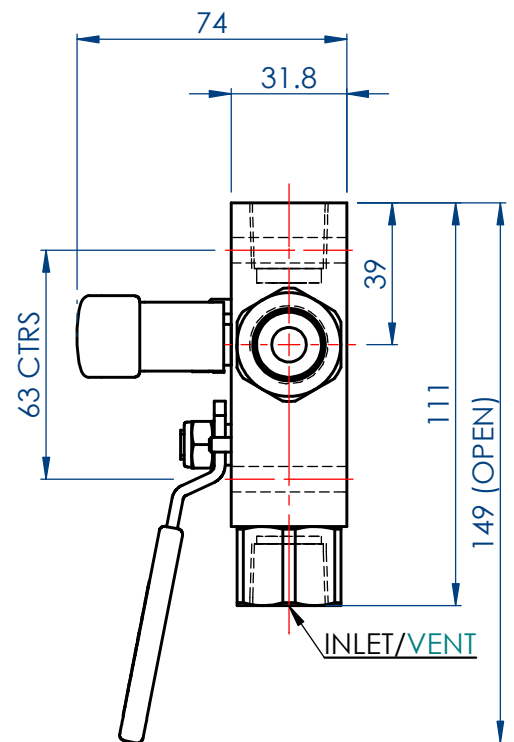
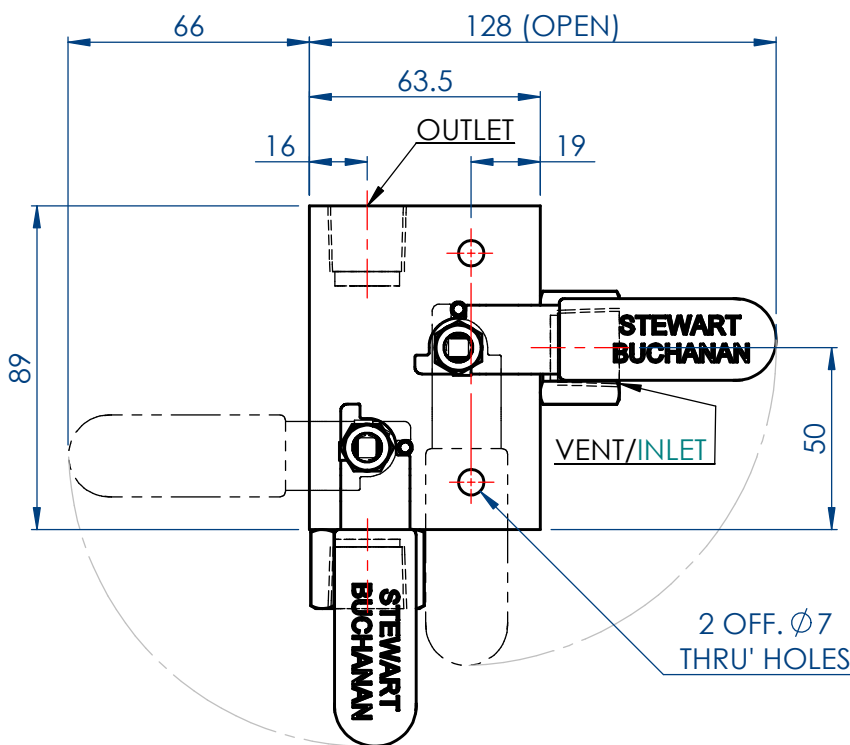

## STEWART-BUCHANAN GAUGES LTD

Sales Office & Manufacturing Facility - 7 Garrell Road, Burnside Industrial Estate Kilsyth, Glasgow G65 9JX, SCOTLAND  
Tel: +44 (0)1236 821533 | Fax: +44 (0)1236 824090 | E-mail: sales@stewarts-group.com | Web: stewarts-group.com

DATA SHEET REF: BVL-REV01-15

