

# RL4803/04 transmitter

## Pro RL4800 Series

Part of the **Hanwell Pro RL4800** series, the RL4803/04 is a digital radio transmitter for use internally or externally. Each unit includes a steel bracket for mounting purposes.

### Features

- ✓ Digital single/dual input for pump, machine, level and door alerts
- ✓ Up to 18 months battery life
- ✓ Superior performance hardware & high accuracy sensors
- ✓ Easily accessible battery
- ✓ Low power radio for long distance transmission (3km over open ground)
- ✓ Complies with RoHS, EU & WEEE directives
- ✓ Carries CE Marking

### Typical Applications

- Level measurement
- Door open/close alerts
- Machine on/off alerts

**Always ask for a long-range signal strength test.**



**We can prove ours to be unrivalled.**



Pump



Machine



Level



Door



Airflow

Photo shows RL4803-434.075 single channel (other frequencies are available)

### Technical specification

Dimensions	150 x 88 x 50mm
Weight	485 grams
Power supply	3.6V AA Lithium battery
Battery life	Up to 18 months (dependent on conditions of use and instrument settings)
Cable length	3m with bare ends (as shown in image)
Case material	ASA & PC
Instrument operating range	-20°C to +60°C (non-condensing RH environment)
Instrument storage Temperature	-40°C to +60°C
IP Rating	IP65

### Product codes

RL4803	Single channel
RL4804	Dual channel
88706	AA Lithium battery

### Radio transmitter functions

Frequency options	A range of frequencies are available between 433-458MHz. Country specific regulations apply.
Radio power	10mW
Radio range	Up to 3km over open ground
Software required	W900 – Standard EMS Software Package W906 – Validated EMS Software Package *See EMS datasheet for further options
Hardware required	SR2 – Smart Receiver REP – Repeater

### Input

Input	Volt free
Maximum load capacitance	10nF
Wetting current	Min 1mA
Measuring frequency	1s
Transmit interval	User programmable 30s-300s on a state change

Manufactured by Hanwell | Ellab RoHS

Version 3 - EC190194

**Disclaimer:** The information contained herein is believed to be reliable. Hanwell Solutions Ltd. is not responsible for any incorrect or incomplete information on this datasheet and the information or product may be changed without notice. Customers should obtain and verify the latest relevant information before placing orders for Hanwell products.

hanwell.com

Tel: +44 (0)1462 688070 | Email: sales@hanwell.com

**Relay schematic**

Note: Ensure the relay is suitable for this application e.g. if fitted with a snubber the capacitance is 10nF or less and the contacts are volt free.

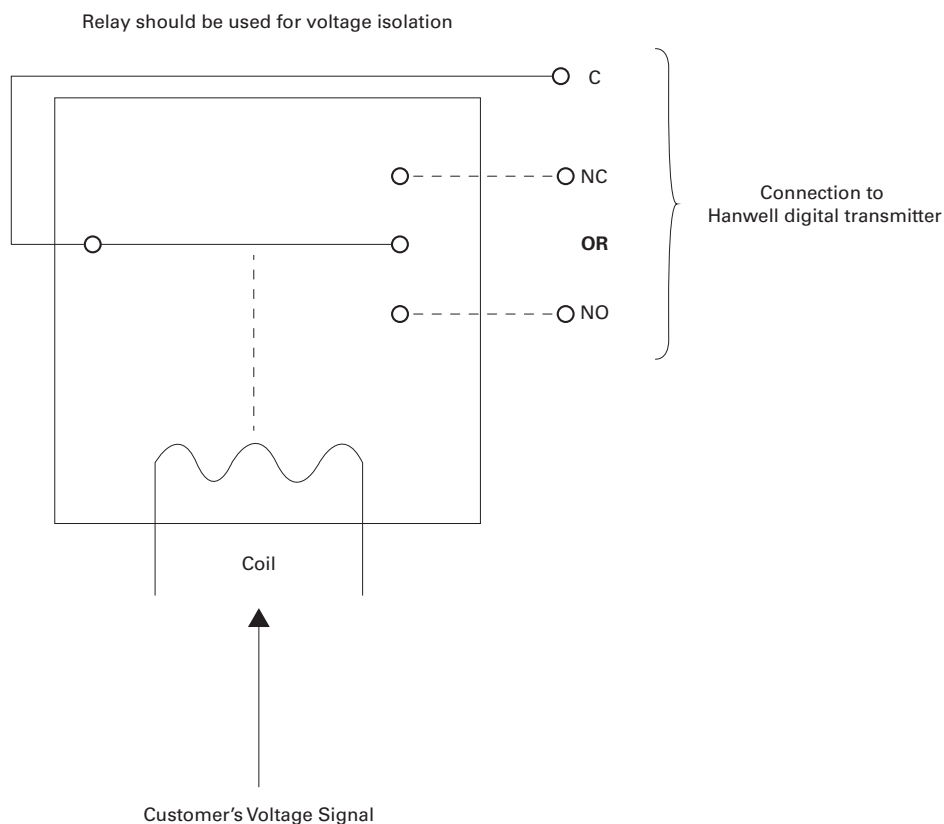

**Warning:** There will be an overall delay of up to 2 minutes from transmitting a state change to a reaction being generated in the central monitoring system. If using SMS there may be a further delay through external third party phone providers.