

Technical Information

STT750 SmartLine Temperature Transmitter Specification 34-TT-03-16, March 2024



Introduction

Part of the SmartLine® family of products, the SmartLine STT750 is a high-performance and value temperature transmitter offering high accuracy and stability over a wide range of process and ambient temperatures. SmartLine easily meets the most demanding needs for temperature measurement applications.

Best in Class Features:

Industry leading performance value

- Digital Accuracy up to .14 Deg C for RTD
- Stability up to +/-0.01% of URL per year for ten years
- 125 mSec update time for single input models.
- 250 mSec update time for dual input models.

Reliable measurement

- Built in Galvanic Isolation
- Dual Compartment Housing
- Sensor Break detection
- Comprehensive on-board diagnostic capabilities
- Full compliance to SIL 2/3 requirements.
- Available with 4-year warranty
- Supports Namur 89 Wire break
- Direct entry of Callendar-van Dusen coefficients R_0 , α , δ and β for calibrated RTD sensors.

Lower Cost of Ownership

- Universal input
- Standard digital display capabilities
- Modular construction
- External zero, span, & configuration capability
- Polarity insensitive loop wiring



Figure 1– SmartLine STT750 Temperature transmitter

Communications/Output Options:

- 4-20 mA DC
- HART® (version 7.0)

All transmitters are available with the above listed output and communication protocol option.

Description

The STT750 SmartLine Temperature Transmitter is designed and manufactured to deliver high performance across varying ambient temperature.

Unique Indication/Display Options

The STT750 modular design accommodates a Standard LCD display.

Standard LCD Display Features

- Modular (may be added or removed in the field).
- 0, 90, 180, & 270-degree position adjustments.
- Deg C, F, R, Kelvin, Milli volts, and Ohm measurement units.
- 2 Lines 6 digits PV (9.95H x 4.20W mm), 8 Characters.
- Device configuration and calibration through integral buttons or optional external buttons.
- Up to 4 configurable display screens.
- Configurable screen rotation timing (2 to 20 sec).
- Write protect indication.
- Critical fault indication.

Configuration Tools

Integral Three Button Configuration Option

Suitable for all electrical and environmental requirements, SmartLine offers the ability to configure the transmitter and display via two buttons on the display and optional three externally accessible buttons. The button compartment is isolated from other internal components and thus keeps the sensitive electronics environmentally sound.

Zero/span capabilities are also optionally available via these buttons with or without selection of a display option.

Handheld Configuration

SmartLine transmitters feature two-way communication and configuration capability between the operator and the transmitter. This is accomplished via Honeywell Versatilis, a field-rated, next-generation multiple communication configuration tool.

The Honeywell Versatilis Handheld is capable of field configuring HART Devices and can also be ordered for use in intrinsically safe environments.

All Honeywell transmitters are designed and tested for compliance with the offered communication protocols and are designed to operate with any properly validated hand-held configuration device.

Personal Computer Configuration

Field Device Manager (FDM) Software and FDM Express are also available for managing HART device configurations.

Diagnostics

SmartLine transmitters all offer digitally accessible diagnostics which aid in providing advanced warning of possible failure events minimizing unplanned shutdowns, providing **lower overall operational costs**

System Integration

- All SmartLine products meet the most current published standards for HART.

Modular Design

To help contain maintenance and inventory costs, all STT750 transmitters are modular in design supporting the user's ability to replace temperature boards, add indicators or change electronic modules without affecting overall performance or approval body certifications.

Each temperature board is uniquely characterized to provide in-tolerance performance over a wide range of application variations in temperature and due to the Honeywell advanced interface, electronic modules may be swapped with any electronics module without losing in-tolerance performance characteristics

Modular Features

- Replace temperature board, terminal board, or lightning protection*
- Replace electronics or communication modules*
- Add or remove integral indicators*
- Add or remove external configuration buttons

* Field replaceable in all electrical environments (including IS) except flameproof without violating agency approvals.

With no performance effects, Honeywell's unique modularity results in **lower inventory needs and lower overall operating costs.**

Performance Specifications^{1,3}**Reference Accuracy²** (conformance to +/-3 Sigma)

Input Type	Maximum Range Limits		Digital Accuracy (+/-)	Output D/A Accuracy (% of span)	Standards
	° C	° F			
RTD (2,3,4 wire)			° C	%	
Pt25 ⁵	-200 to 850	-328 to 1562	0.90	0.025	IEC751 ($\alpha=0.00385$)
Pt100	-200 to 850	-328 to 1562	0.14	0.025	IEC751 ($\alpha=0.00385$)
Pt200	-200 to 850	-328 to 1562	0.28	0.025	IEC751($\alpha=0.00385$)
Pt500	-200 to 850	-328 to 1562	0.17	0.025	IEC751 ($\alpha=0.00385$)
Pt1000	-200 to 500	-328 to 932	0.14	0.025	IEC751 ($\alpha=0.00385$)
Ni120	-80 to 260	-112 to 500	0.12	0.025	Edison Curve #7 ($\alpha=0.00672$)
Cu10	-50 to 250	-58 to 482	1.40	0.025	Edison Copper Winding #15 ($\alpha=0.00427$)
Thermocouples	° C	° F	° C	%	
B	200 to 300	392 to 572	3.00	0.025	IEC 584-1 (ITS-90)
	300 to 1820	572 to 3308	1.20	0.025	IEC 584-1 (ITS-90)
E	-200 to 1000	-328 to 1832	0.40	0.025	IEC 584-1 (ITS-90)
J	-200 to 1200	-328 to 2192	0.50	0.025	IEC 584-1 (ITS-90)
K	-200 to 1370	-328 to 2498	0.50	0.025	IEC 584-1 (ITS-90)
N	-200 to 1300	-328 to 2372	0.80	0.025	IEC 584-1 (ITS-90)
R	-50 to 0	-58 to 32	2.00	0.025	IEC 584-1 (ITS-90)
	0 to 1760	32 to 3200	1.00	0.025	IEC 584-1 (ITS-90)
S	-50 to 0	-58 to 32	2.00	0.025	IEC 584-1 (ITS-90)
	0 to 1760	32 to 3200	1.00	0.025	IEC 584-1 (ITS-90)
T	-250 to -200	-418 to 392	1.2	0.025	IEC 584-1 (ITS-90)
	-200 to 400	-392 to 752	0.40	0.025	IEC 584-1 (ITS-90)
C (W ₅ W ₂₆)	0 to 2300	32 to 4172	1.20	0.025	ANSI/ASTM E-230 (ITS-90)

Other Input Types	Maximum Range Limits	Digital Accuracy (+/-)	Output D/A Accuracy (% of span)	Standards
Millivolts	-100 to 1200 mV	0.17 mV	0.025	
Millivolts	-20 to 125 mV	0.021 mV	0.025	
Ohms	0 to 500 Ohms	0.30 Ohms	0.025	
Ohms	0 to 2000 Ohms	0.45 Ohms	0.025	
Ohms	0 to 3000 Ohms	0.65 Ohms	0.025	

1. Digital Accuracy is accuracy of the digital value accessed by the Host system and the handheld communicator.

2. Total analog accuracy is the sum of digital accuracy and output D/A Accuracy.

3. Output D/A Accuracy is applicable to the 4 to 20 mA Signal output.

4. For TC inputs, CJ accuracy shall be added to digital accuracy to calculate the total digital accuracy.

5. Custom Callendar-van Dusen not available for Pt25 sensors.

Performance under Rated Conditions – All Models

Parameter	Description									
Input Span Adjustment Range	No limits to adjustments within the maximum range except minimum span limit of 1 engineering unit									
Analog Output	Two-wire, 4 to 20 mA (HART transmitters only)									
Digital Communications:	HART 7 protocol compliant									
Output Failure Modes (HART only)	<table style="width: 100%; border: none;"> <tr> <td style="width: 33%;"></td> <td style="width: 33%; text-align: center;">Honeywell Standard:</td> <td style="width: 33%; text-align: center;">NAMUR NE 43 Compliance:</td> </tr> <tr> <td>Normal Limits:</td> <td style="text-align: center;">3.8 – 20.8 mA</td> <td style="text-align: center;">3.8 – 20.5 mA</td> </tr> <tr> <td>Failure Mode:</td> <td style="text-align: center;">≤ 3.6 mA and ≥ 21.0 mA</td> <td style="text-align: center;">≤ 3.6 mA and ≥ 21.0 mA</td> </tr> </table>		Honeywell Standard:	NAMUR NE 43 Compliance:	Normal Limits:	3.8 – 20.8 mA	3.8 – 20.5 mA	Failure Mode:	≤ 3.6 mA and ≥ 21.0 mA	≤ 3.6 mA and ≥ 21.0 mA
	Honeywell Standard:	NAMUR NE 43 Compliance:								
Normal Limits:	3.8 – 20.8 mA	3.8 – 20.5 mA								
Failure Mode:	≤ 3.6 mA and ≥ 21.0 mA	≤ 3.6 mA and ≥ 21.0 mA								
Output Accuracy (HART only)	±0.025 % span									
Supply Voltage Effect	0.005 % span per volt.									
Transmitter Turn on Time (includes power up & test algorithms)	HART: 2.5 sec.									
Analog Input	Stability: 0.01% of URL per year for 10 years Maximum Lead Wire Resistance: Thermocouples: 50 ohms/leg RTD (all except Pt25) and ohms: 50 ohms/leg RTD Pt25: 10 ohms/leg									
Response Time (delay + time constant)	HART Analog Output 130 - 230 mSec									
Update time	125 mSec									
Damping Time Constant	HART: Adjustable from 0 to 102 seconds in 0.1 increments. Default: 0.50 seconds									
Ambient Temperature Effect	Digital Accuracy For RTD Inputs, 0.0025 °C/°C For T/C Inputs: 0.010 °C/°C Output D/A: 0.0010 % of span/°C									
Cold Junction Accuracy	±0.25 °C									
Total Reference Accuracy	Digital Mode : Digital Accuracy + C/J Accuracy (T/C input types only) Analog Mode (HART only): Digital Accuracy + Output D/A Accuracy + C/J Accuracy (T/C input types only) Example: Transmitter in Analog Mode with Pt100 sensor and 0 to 200°C range Total Reference Accuracy = 0.14°C + (200 °C / 100 %) * 0.025 % = 0.19 °C									
Sensor Burnout	Burnout detection is user selectable. Upscale or down scale with critical status message. For RTD or ohm type inputs; broken wire/wires will be indicated									
Vibration Effect	Per IEC60770-1 field or pipeline, high vibration level (10-2000Hz: 0.21 displacement/3g max acceleration)									
Electromagnetic Compatibility	IEC 61326-3-1									
Isolation	2000 Vdc (1400Vrms) Galvanic isolation between inputs and output.									
Stray Rejection	Common Mode <i>AC (50 or 60 Hz):</i> 120 dB (with maximum source impedance of 100 ohms) or ± 1 LSB (least significant bit) whichever is greater with line voltage applied. <i>DC:</i> 120 dB (with maximum source impedance of 50 ohms) or a ±1 LSB whichever is greater with 120 Vdc applied. <i>DC (to 1 KHz):</i> 50 dB (with maximum source of impedance of 50 ohms) or ±1 LSB whichever is greater with 50 Vac applied. Normal Mode <i>AC (50 or 60 Hz):</i> 60 dB (with 100% span peak-to-peak maximum)									
EMC Compliance	EN 61326-1 and EN 61326-3-1 (SIL)									
Lightning Protection Option	Leakage Current: 10 uA max @ 42.4 VDC 85 °C Impulse rating: <table style="width: 100%; border: none;"> <tr> <td style="width: 33%;">8/20 uS</td> <td style="width: 33%;">5000 A (>10 strikes)</td> <td style="width: 33%;">10000 A (1 strike min.)</td> </tr> <tr> <td>10/1000 uS</td> <td>200 A (> 300 strikes)</td> <td></td> </tr> </table>	8/20 uS	5000 A (>10 strikes)	10000 A (1 strike min.)	10/1000 uS	200 A (> 300 strikes)				
8/20 uS	5000 A (>10 strikes)	10000 A (1 strike min.)								
10/1000 uS	200 A (> 300 strikes)									

EMC Conformity (CE, Marine and SIL)

The STT750 device is compliant with IEC compliance EN 61326-1: 2013, EN IEC 61326-1: 2021 (CE) ; IEC 60533: 2015 / IACS Req. 1991/Rev.8 2021 (Marine) and IEC 61326-3-1: 2017 (SIL)

Performance specifications under EMC conditions (CE and Marine):

HART: Worst case deviation < 0.1% of full span (for both Analog and Digital).

Operating Conditions – All Models

Parameter	Reference Condition		Rated Condition		Operative Limits		Transportation and Storage	
	°C	°F	°C	°F	°C	°F	°C	°F
Ambient Temperature ¹ STT750	25±1	77±2	-40 to 85	-40 to 185	-40 to 85	-40 to 185	-55 to 120	-67 to 248
Humidity %RH	10 to 55		0 to 100		0 to 100		0 to 100	
Supply Voltage Load Resistance	HART Models: 11.8 to 42.4 Vdc at terminals (IS versions limited to 30 Vdc) 0 to 1,400 ohms (as shown in Figure 2)							

¹ LCD Display operating temperature -20°C to +70°C . Storage temperature -30°C to 80°C.

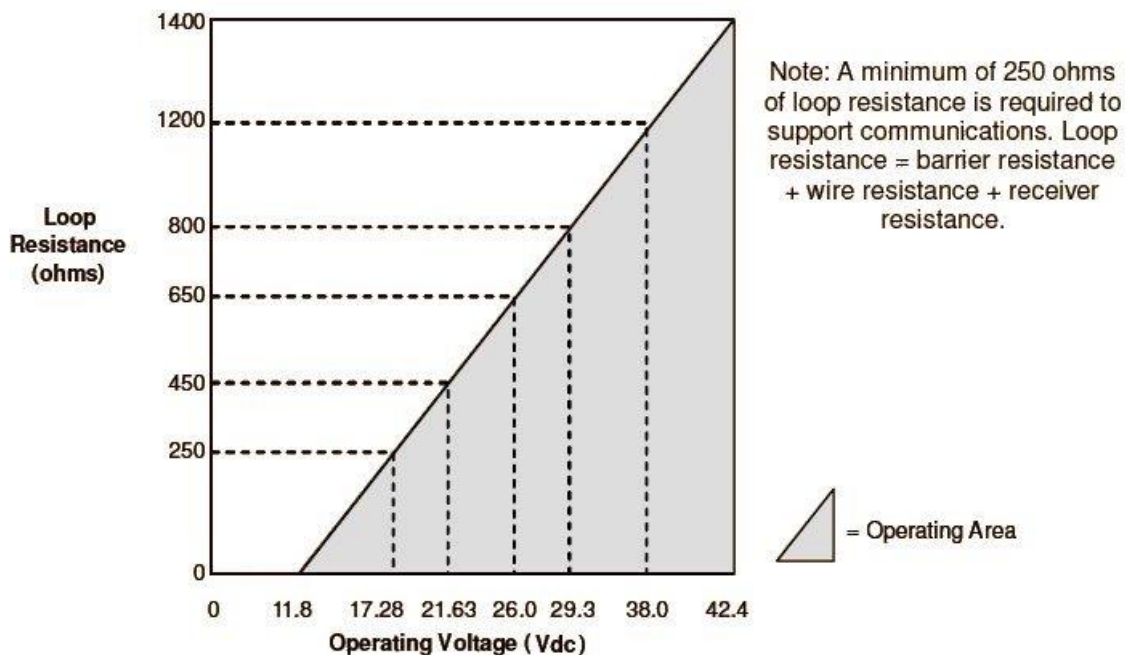

$$R_{Lmax} = 45.6 \times (\text{Power Supply Voltage} - 11.8)$$

Figure 2 – HART Supply voltage and loop resistance chart & calculations

Materials Specifications (see model selection guide for availability/restrictions with various models)

Parameter	Description
Mounting Bracket	Wall or 2" Pipe, Carbon Steel (Zinc-plated) or 316 Stainless Steel
Electronic Housing	Pure Polyester Powder Coated Low Copper (<0.4%) – Aluminum. Meets Type 4X / IP66 / IP67. All stainless steel housing is optional. Cover O ring material: Silicone
Sensor/Cable Entry	1/2 NPT electrical connection or M20x1.5
Mounting	Can be mounted in virtually any position using the standard mounting brackets. Brackets are designed to mount onto a wall or a 2-inch (50 mm) vertical or horizontal pipe.
Wiring	Accepts up to 16 AWG (1.5 mm diameter). Preferred 18AWG and above for ease of wiring.
Dimensions	See Figures 4 to 9
Net Weight Lbs (kg)	Aluminum housing for transmitter with Display – 2.7 lbs (1.22 kg) Aluminum housing for transmitter w/o Display – 2.6 lbs (1.18 kg) Stainless Steel housing for transmitter with Display – 4.9 lbs (2.22 kg) Stainless Steel housing for transmitter w/o Display – 4.8 lbs (2.18 kg)

Communications Protocols & Diagnostics**HART Protocol****Version:**

HART 7

Power Supply

Voltage: 11.8 to 42.4Vdc at terminals

Load: Maximum 1400 ohms See figure 2

Minimum Load: 0 ohms. (For handheld communications, a minimum load of 250 ohms is required)

IEC 61508 Safety Certified SIL 2 and SIL 3

Standard Diagnostics

STT750 top level diagnostics are reported as either critical or non-critical as listed below. All diagnostics are readable via the DD/DTM tools. All critical diagnostics will appear on the integral display.

Critical Diagnostics

Sensor Module Fault

Communications Module Fault

Sensor Communications Fault

Input Fault

SIL 2/3 Certification	IEC 61508 SIL 2 for non-redundant use and SIL 3 for redundant use according to EXIDA and TÜV Nord Sys Tec GmbH & Co. KG under the following standards: IEC61508-1: 2010; IEC 61508-2: 2010; IEC61508-3: 2010. SIL EMI/EMC compliance as per Standard: IEC 61326-3-1: 2017
MARINE TYPE APPROVAL	American Bureau of Shipping (ABS); Certificate number: 23-2416104-PD Lloyd's Register (LR); Certificate number: LR23389941TA

Wiring Diagram

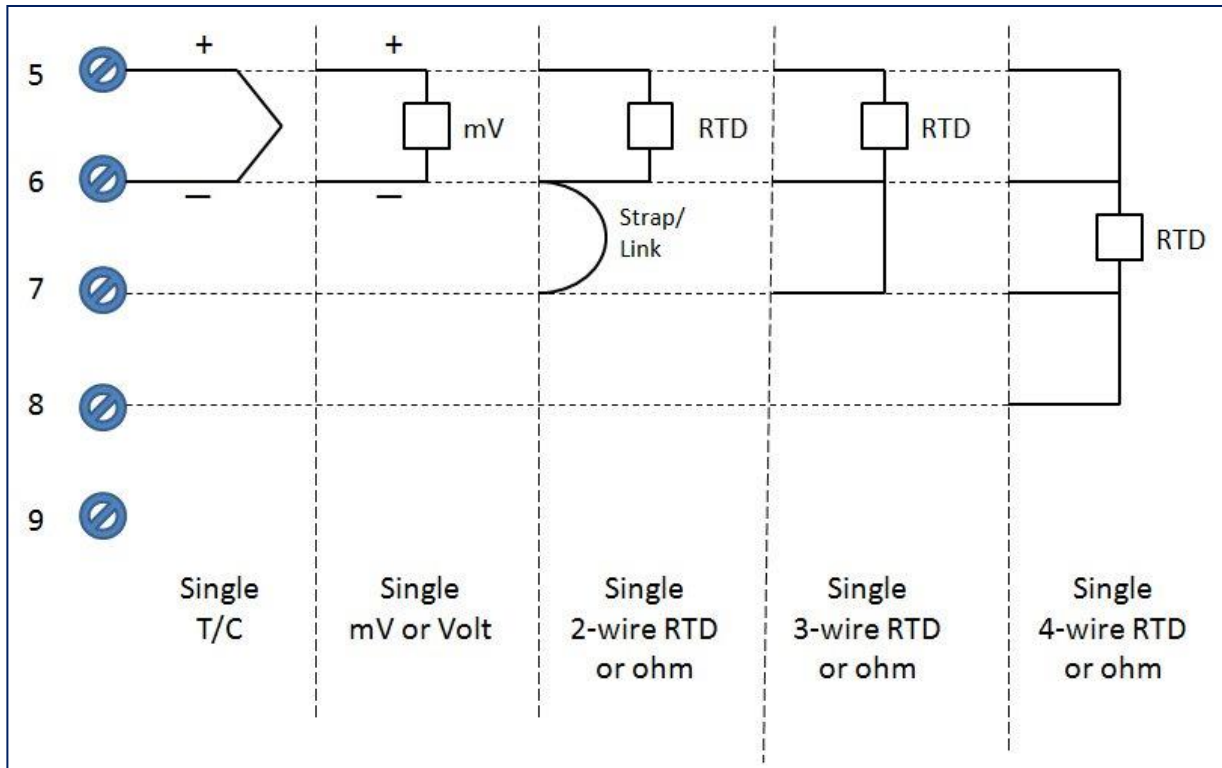

Figure 3 STT750 Thermocouple, RTD, mV, ohm and Volt Connections

Approval Certifications:

MSG CODE	AGENCY	TYPE OF PROTECTION	COMM OPTION	Electrical Parameters	Ambient Temperature
A	FM Approvals™ (USA)	Explosion proof , Certificate: FM16US0157X: Class I, Division 1, Groups A, B, C, D; Dust Ignition Proof: Class II, III, Division 1, Groups E, F, G; T6..T5 Class 1, Zone 1, AEx db IIC T6..T5 Gb Zone 21 AEx tb IIIC T 95°C Db	4-20 mA/ DE/HART/ F/ PROFIBUS	Note 1	T 95°C, T5: Ta= -50°C to 85°C T6: Ta= -50°C to 65°C
		Intrinsically Safe , Certificate: FM16US0157X: Class I, II, III, Division 1, Groups A, B, C, D, E, F, G; T4 Class I Zone 0 AEx ia IIC T4 Ga FISCO Field Device (Only for FF Option) Class I Zone 0 Ex ia IIC T4 Ga	4-20 mA/ DE/HART/FF/ PROFIBUS	Note 2	-50°C to 70°C FISCO: -50°C to 45°C
		Non-Incendive , Certificate: FM16US0157X: Class I, Division 2, Groups A, B, C, D; T4 Class I Zone 2 AEx nA IIC T4 Gc	4-20 mA/ DE/HART/FF/ PROFIBUS	Note 1	-50°C to 85°C
		Enclosure: Type 4X/ IP66/ IP67	ALL	ALL	ALL
B	CSA-Canada and USA	Explosion proof , Certificate: 2689056: Class I, Division 1, Groups A, B, C, D; Dust Ignition Proof: Class II, Division 1, Groups E, F, G; Class III, Division 1 ;T6..T5 Class I Zone 1 AEx db IIC T6..T5 Gb ; Zone 21 Ex tb IIIC T 95°C Db Ex db IIC T6..T5 Gb ; Ex tb IIIC T 95°C Db	4-20 mA/ DE/HART/FF	Note 1	T 95°C, T5: Ta= -50°C to 85°C T6: Ta= -50°C to 65°C
		Intrinsically Safe , Certificate: 2689056: Class I, II, III, Division 1, Groups A, B, C, D, E, F, G; T4 Class I Zone 0 AEx ia IIC T4 Ga Class I Zone 2 Ex ic IIC T4 Gc Ex ia IIC T4 Ga Ex ic IIC T4 Gc FISCO Field Device (Only for FF Option) Class I Zone 0 AEx ia IIC T4 Ga Class I Zone 2Ex ic IIC T4 Gc Ex ia IIC T4 Ga Ex ic IIC T4 Gc	4-20 mA/ DE/HART/FF	Note 2	-50°C to 70°C FISCO: -50°C to 45°C
		Non-Incendive , Certificate: 2689056: Class I, Division 2, Groups A, B, C, D; T4 Class I Zone 2 AEx nA IIC T4 Gc Ex nA IIC T4 Gc	4-20 mA/ DE/HART/FF	Note 1	-50°C to 85°C
		Enclosure: Type 4X/ IP66/ IP67	ALL	ALL	ALL

B		<p>Standards: CSA C22.2 No. 0-10; CSA 22.2 No. 25-1966 (reaffirmed 2009); CSA C22.2 No. 30-M1986 (reaffirmed 2012); CSA C22.2 No. 94-M91; CSA C22.2 No. 61010-1: 2012; CSA-C22.2No.157-92 (reaffirmed 2012); C22.2 No. 213-2017; C22.2 No. 60529-2016 C22.2 No. CSA 60079-0:2011; C22.2 No. 60079-1: 2011; C22.2 No. 60079-11:2014; C22.2 No. 60079-15: 2012; C22.2 No. 60079-31:2015;</p> <p>ANSI/ ISA12.12.01-2017; ANSI/ ISA 60079-0 (12.00.01): 2013; ANSI/UL 60079-1 : 2015; ANSI/ ISA 60079-11(12.02.01) : 2012; ANSI/ ISA 60079-15(12.12.02) : 2012 ; ANSI/ ISA 60079-31: 2015; FM Class 3615: Aug 2006; FM Class 3616: Dec 2011; ANSI/ IEC 60529 : Edition 2.1 ANSI/ UL 913: 2015; ANSI/UL 61010-1: 2016; UL 50: Ed 11</p>			
C	ATEX	<p>Flameproof, Sira 14ATEX2046X: II 2 GD Ex db IIC T6..T5 Gb Ex tb IIIC T 95°C Db</p>	4-20 mA/ DE/HART/FF	Note 1	T 95°C, T5: Ta= -50°C to 85°C T6: Ta= -50°C to 65°C
		<p>Intrinsically Safe, Sira 14ATEX2046X: II 1 GD Ex ia IIC T4 Ga Ex ia IIIC T95°C Da FISCO Field Device (Only for FF Option) Ex ia IIC T4 Ga</p>	4-20 mA/ DE/HART/FF	Note 2	-50°C to 70°C FISCO: -50°C to 45°C
		<p>Enclosure: IP66/ IP67</p>	ALL	ALL	ALL
		<p>Standards: EN 60079-0: 2012/A11:2013; EN 60079-1 : 2014; EN 60079-31 : 2014 EN 60079-11: 2011; EN 60079-26 : 2006; EN 60529 : 2000 + A1</p>			
		<p>Increase Safety/ Intrinsic Safety, Sira 14ATEX4052X: II 3 G Ex ec IIC T4 Gc Ex ic IIC T4 Gc FISCO Field Device (Only for FF Option) Ex ic IIC T4 Gc</p>	4-20 mA/ DE/HART/FF	Note 1	-50°C to 85°C FISCO: -50°C to 45°C
		<p>Enclosure: IP66/ IP67</p>	ALL	ALL	ALL
		<p>Standards: EN 60079-0: 2012/A11:2013; EN 60079-7:2015; EN 60079-11:2012</p>			
D	IECEx	<p>Flameproof, SIR 14.0020X Ex db IIC T6..T5 Gb Ex tb IIIC T 95°C Db</p>	4-20 mA/ DE/HART/FF	Note 1	T 95°C, T5: Ta= -50°C to 85°C T6: Ta= -50°C to 65°C
		<p>Intrinsically Safe, SIR 14.0020X Ex ia IIC T4 Ga Ex ia IIIC T95°C Da FISCO Field Device (Only for FF Option) Ex ia IIC T4 Ga</p>	4-20 mA/ DE/HART/ FF	Note 2	-50°C to 70°C FISCO: -50°C to 45°C
		<p>Non Sparking, SIR 14.0020X Ex ecIIC T4 Gc Ex ic IIC T4 Gc FISCO Field Device (Only for FF Option) Ex ic IIC T4 Gc</p>	4-20 mA/ DE/HART/ FF	Note 1	-50°C to 85°C FISCO: -50°C to 45°C
		<p>Enclosure: IP66/ IP67</p>	ALL	ALL	ALL
		<p>Standards: IEC 60079-0: 2011; IEC 60079-1 : 2014,; IEC 60079-11 : 2011; IEC 60079-7:2015; IEC 60079-31 : 2013</p>			

E	SAEx (South Africa)	Flameproof: Ex db IIC T6..T5 Gb Ex tb IIIC T 95°C Db	4-20 mA/ DE/HART/FF	Note 1	T 95°C, T5: Ta= --50°C to 85°C T6: Ta= -50°C to 65°C
		Intrinsically Safe: Ex ia IIC T4 Ga Ex ia IIIC T95°C Da FISCO Field Device (Only for FF Option) Ex ia IIC T4 Ga	4-20 mA/ DE/HART/FF	Note 2	-50°C to 70°C FISCO: -50°C to 45°C
		Increase Safety/ Intrinsic Safety: Ex ec IIC T4 Gc Ex ic IIC T4 Gc FISCO Field Device (Only for FF Option) Ex ic IIC T4 Gc	4-20 mA/ DE/HART/FF	Note 1	-50°C to 85°C FISCO: -50°C to 45°C
		Enclosure: IP66/ IP67	ALL	ALL	ALL
F	INMETRO	Flameproof: Ex db IIC T6..T5 Gb Ex tb IIIC T 95°C Db	4-20 mA/ DE/HART/FF	Note 1	T 95°C, T5: Ta= -50°C to 85°C T6: Ta= -50°C to 65°C
		Intrinsically Safe: Ex ia IIC T4 Ga Ex ia IIIC T95°C Da FISCO Field Device (Only for FF Option) Ex ia IIC T4 Ga	4-20 mA/ DE/HART/FF	Note 2	-50°C to 70°C FISCO: -50°C to 45°C
		Increase Safety/ Intrinsic Safety: Ex ec IIC T4 Gc Ex ic IIC T4 Gc FISCO Field Device (Only for FF Option) Ex ic IIC T4 Gc	4-20 mA/ DE/HART/FF	Note 1	-50°C to 85°C FISCO: -50°C to 45°C
		Enclosure: IP66/ IP67	ALL	ALL	ALL
G	NEPSI (CHINA)	Flameproof: Ex d IIC T6..T5 Gb Ex tD A21 IP66/IP67 T95°C	4-20 mA/ DE/HART/FF	Note 1	T 95°C, T5: Ta= -50°C to 85°C T6: Ta= -50°C to 65°C
		Intrinsically Safe: Ex ia IIC T4 Ex iaD 20 T95°C FISCO Field Device (Only for FF Option) Ex ia IIC T4	4-20 mA/ DE/HART/FF	Note 2	-50°C to 70°C FISCO: -50°C to 45°C
		Non Sparking/ Intrinsic Safety: Ex nA IIC T4 Ex ic IIC T4 Gc	4-20 mA/ DE/HART/FF	Note 1	-50°C to 85°C
		Enclosure: IP66/ IP67	ALL	ALL	ALL
H	KOSHA (KOREA)	Flameproof: Ex d IIC T4 Gb Ex tD A21 T 95°C IP 66/ IP67	4-20 mA/ DE/HART/FF	Note 1	-50°C to 85°C
		Intrinsically Safe: Ex ia IIC T4 FISCO Field Device (Only for FF Option) Ex ia IIC T4	4-20 mA/ DE/HART/FF	Note 2	-50°C to 70°C FISCO: -50°C to 45°C
		Enclosure: IP66/ IP67	ALL	ALL	ALL

J	EAC Ex (Russia, Belarus and Kazakhstan)	Flameproof: 1 Ex d IIC T4 Gb Ex tb IIIC T95°C Db	4-20 mA/ DE/HART/FF	Note 1	-50°C to 85°C
		Intrinsically Safe: 0 Ex ia IIC T4 Ga Ex ia IIIC T4 Db FISCO Field Device (Only for FF Option) 0 Ex ia IIC T4 Ga	4-20 mA/ DE/HART/FF	Note 2	-50°C to 70°C FISCO: -50°C to 45°C
		Non Sparking: 2 Ex nAc IIC T4	4-20 mA/ DE/HART/FF	Note 1	-50°C to 85°C
		Enclosure: IP66/ IP67	ALL	ALL	ALL
P	CCoE (India)	Ex ia IIC T4 Ga FISCO Field Device (Only for FF Option) Ex ia IIC T4	4-20 mA/ DE/HART/FF	Note 2	-50°C to 70°C FISCO: -50°C to 45°C
		Ex d IIC T4 Gb	4-20 mA/ DE/HART/FF	Note 1	-50°C to 85°C

Notes

1. Operating Parameters:

4-20 mA/ HART (Loop Terminal)

Voltage= 11.8 to 42 V Current= 4-20 mA Normal (3.8 – 23 mA Faults)

2. Intrinsically Safe Entity Parameters

Analog/HART Entity Values

Loop, Terminals 1 and 2:

$V_{max} = U_i = 30V$	$I_{max} = I_i = 225mA$	$C_i = 12nF$	$L_i = 0\mu H$	$P_i = 0.9W$
-----------------------	-------------------------	--------------	----------------	--------------

Temperature Sensor, Terminals 5, 6, 7 and 8:

$U_o = 5.9V$	$I_{max} = I_o = 2.65mA$	$C_o = 39\mu F$	$L_o = 4.99H$	$P_o = 15.48mW$
--------------	--------------------------	-----------------	---------------	-----------------

ounting & Dimensional Drawings

TRANSMITTER ENCLOSURE CAN BE ROTATED A TOTAL OF 90° FROM THE STANDARD MOUNTING POSITION

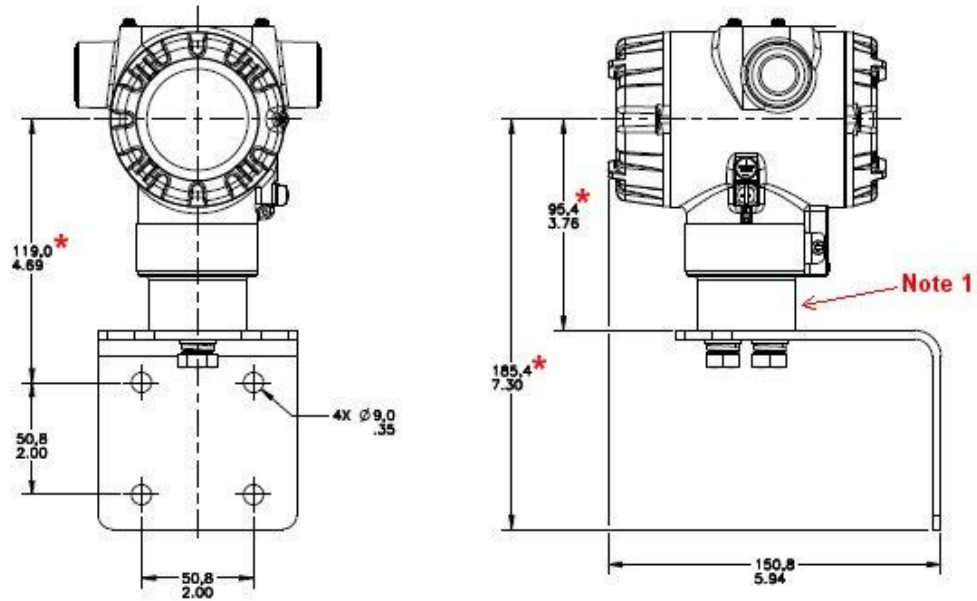
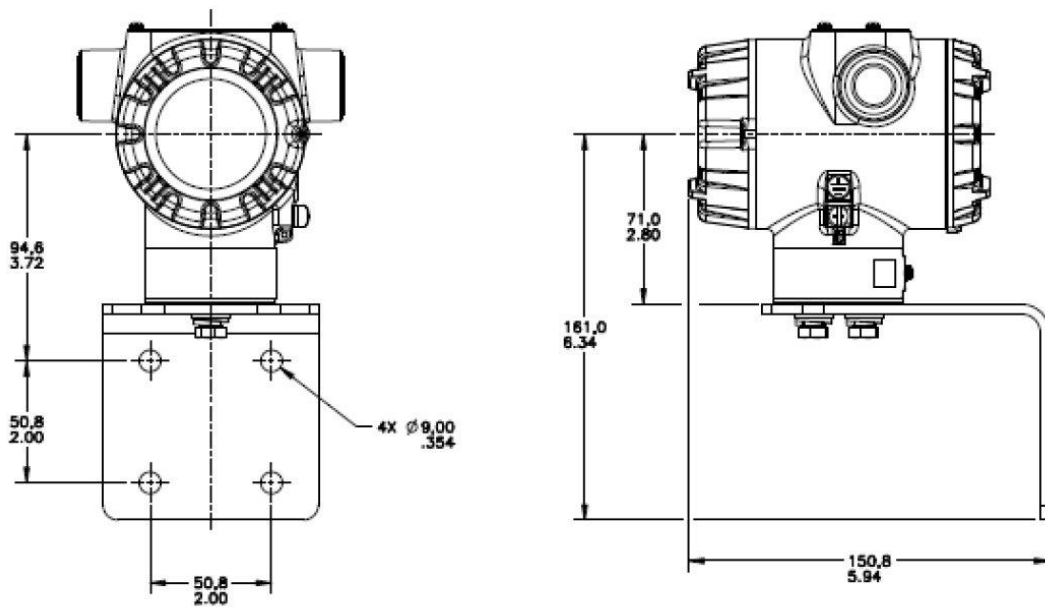

Figure 4 – STT750 with adapter housing - Horizontal Wall Mounting



HORIZONTAL WALL MOUNT

TRANSMITTER ENCLOSURE CAN BE ROTATED A TOTAL OF 90° FROM THE MOUNTING POSITION SELECTED

Figure 5 – STT750 No-Adapter Horizontal Wall Mounting

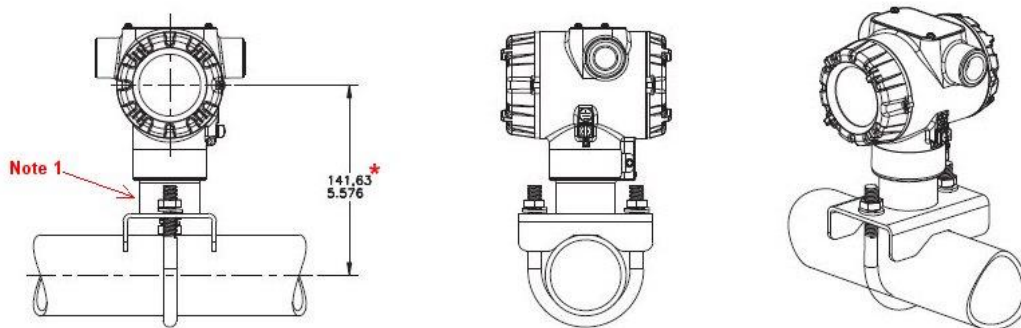

HORIZONTAL FLAT PIPE MOUNT

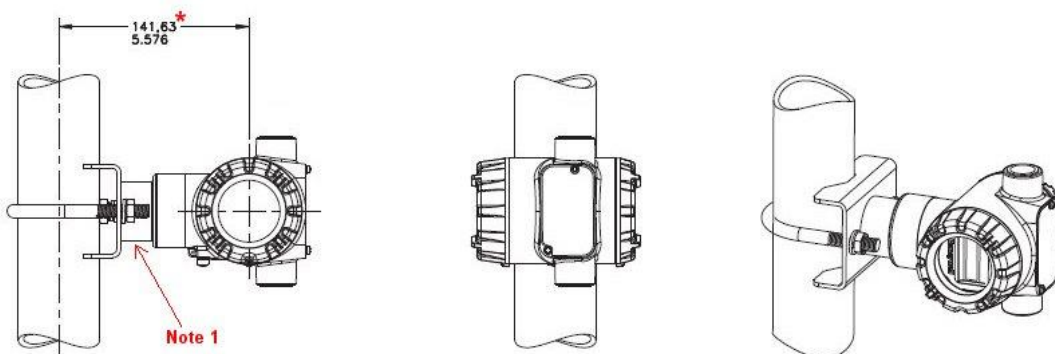

VERTICAL FLAT PIPE MOUNT

Figure 6 – STT750 Pipe Mount with adapter housing - Horizontal & Vertical

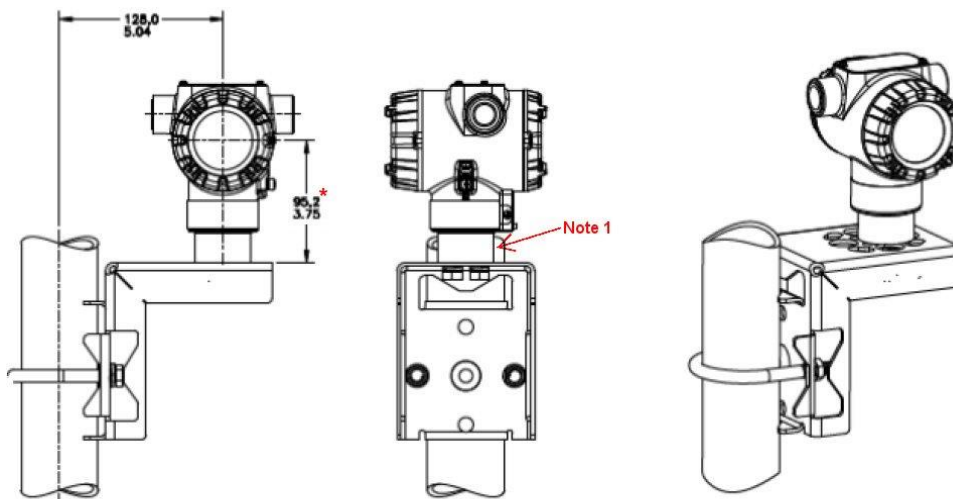

VERTICAL ANGLE PIPE MOUNT

Figure 7 – STT750 Pipe Mount, Vertical

* **Note 1:** Figure 6 and 7. The housing adapter may not be present on all transmitter models. If the housing adapter is not present, subtract 24,5mm (0,96 inches) from the dimension specified.

Mounting & Dimensional Drawings

Reference Dimensions: $\frac{\text{millimeters}}{\text{inches}}$

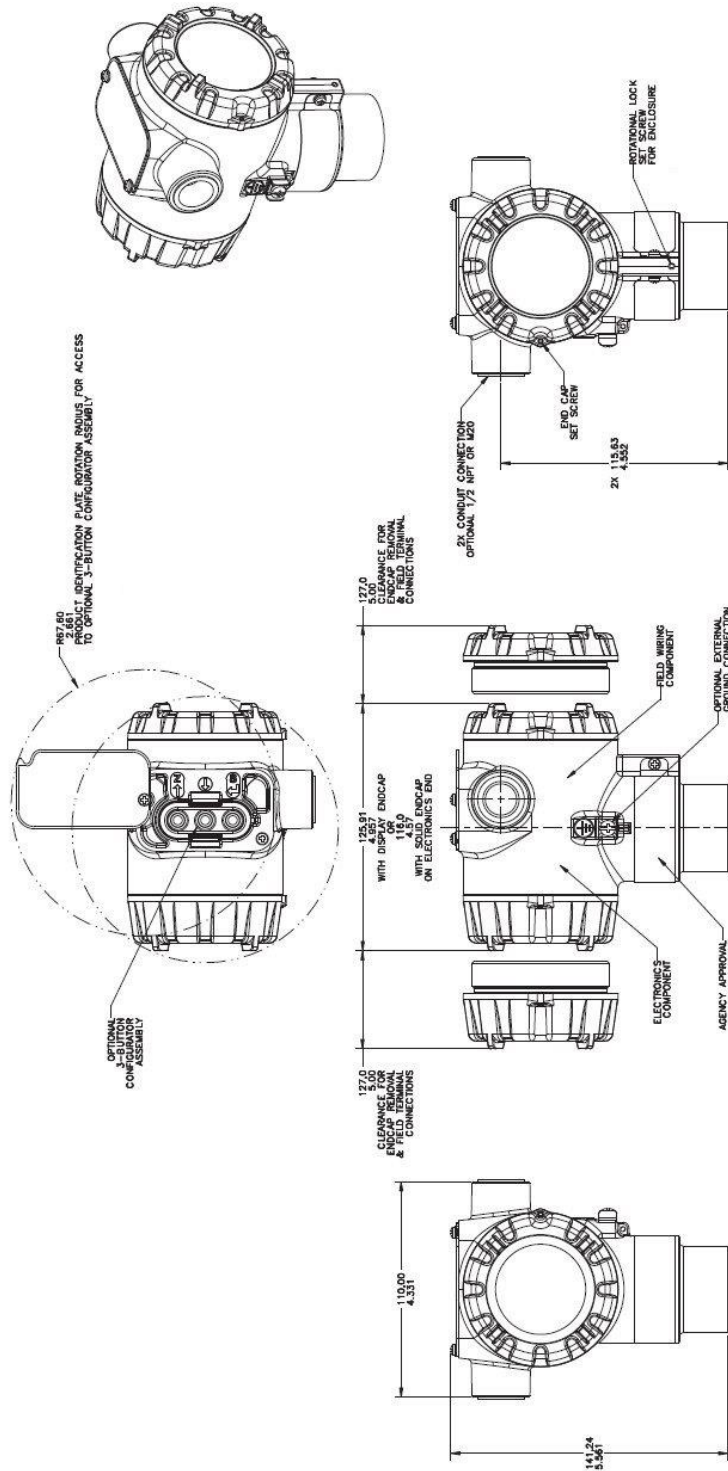

Figure 8 – STT750 with adapter housing - Dimensions

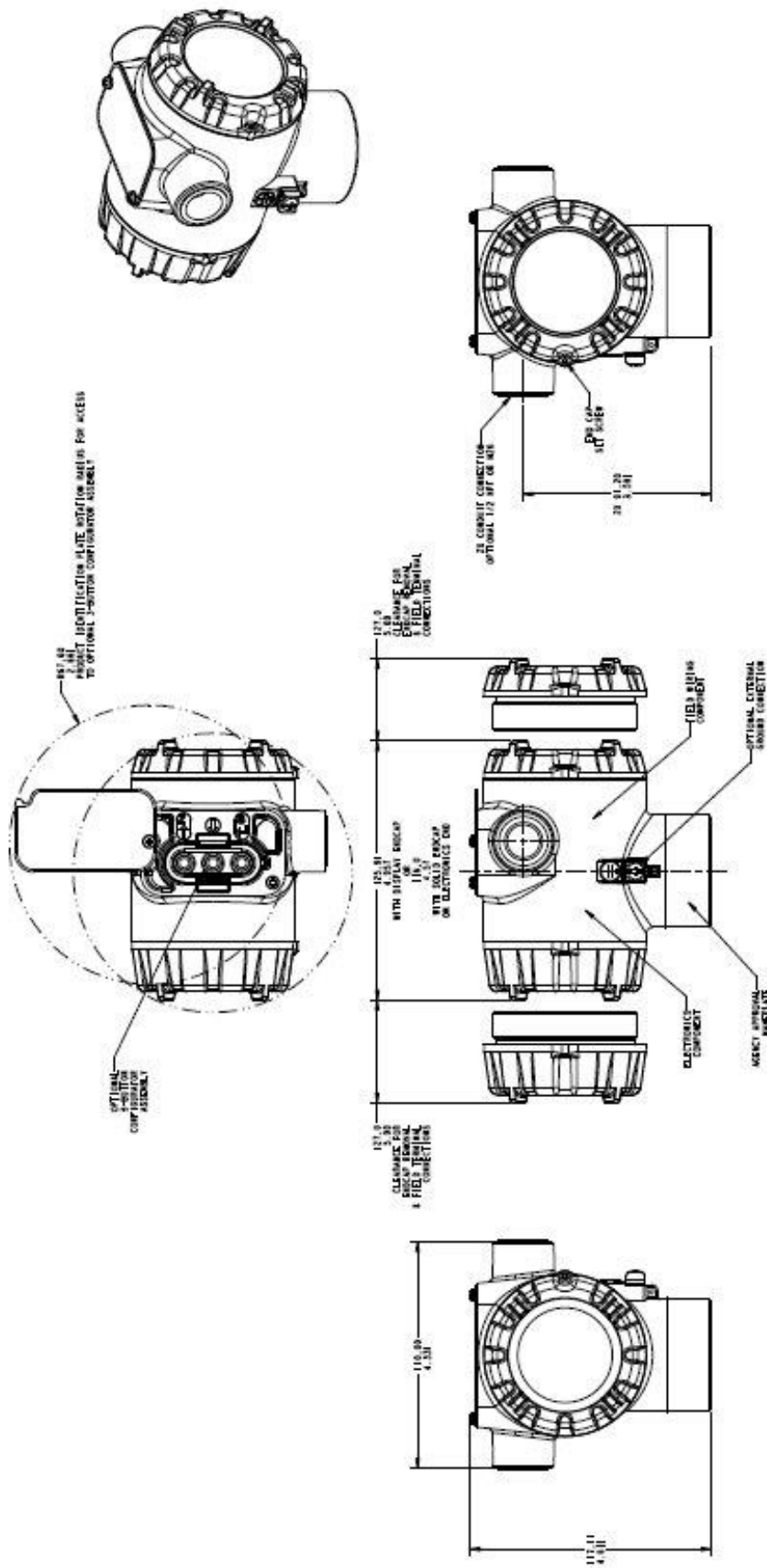

Figure 9 – STT750 no adapter housing dimensions

The Model Selection Guide is subject to change and is inserted into the specification as guidance only.

Model Selection Guide



Section 13
Page: STT7-1
Effective Date: January 12, 2024



Model STT750
Smart Temperature Transmitter

Model Selection Guide

Model Selection Guide:
 34-44-16-20 Issue 21

Honeywell Proprietary

Instructions: Make selections from all Tables Key through XIII using column below the proper arrow. Asterisk indicates availability. Letter (a) refer to restrictions highlighted in the restrictions table. Tables delimited with dashes.
List Price: Price equals the sum of prices for all selections made.

Key	I	II	III	IV	V	VI	VII	VIII	IX
STT750	-	-	-	-	-	-	-	-	X X X X

List Price equals the sum of all selections made.

KEY NUMBER	INPUT TYPE
	Universal Input

Availability Selection

STT750	*
--------	---

TABLE I	NUMBER OF INPUTS
Input Details	Single

S	*
---	---

TABLE II	DIGITAL OUTPUT
Digital Output	No

0	*
---	---

TABLE III	AGENCY APPROVALS (See data sheet for Approval Code Details)
Approvals	No Approvals Required
	FM Explosion proof, Intrinsically Safe, Non-incendive, & Dustproof
	CSA Explosion proof, Intrinsically Safe, Non-incendive, & Dustproof
	ATEX Explosion proof, Intrinsically Safe & Non-incendive
	IECEX Explosion proof, Intrinsically Safe & Non-incendive
	SAEx Explosion proof, Intrinsically Safe & Non-incendive
	INMETRO Explosion proof, Intrinsically Safe & Non-incendive
	NEPSI Explosion proof, Intrinsically Safe & Non-incendive
	KOSHA Explosion proof, Intrinsically Safe & Non-incendive
	EAC Explosion proof, Intrinsically Safe & Non-incendive
	CCoE Explosion proof, Intrinsically Safe & Non-incendive

0	*
A	*
B	*
C	*
D	*
E	*
F	*
G	*
H	*
J	*
P	*

TABLE IV	TRANSMITTER ELECTRONICS SELECTIONS		
a. Electronic Housing Material & Connection Type	Housing and Material		Connection
	Polyester Powder Coated Aluminum		1/2 NPT
	Polyester Powder Coated Aluminum		M20
	316 Stainless Steel (Grade CF8M)		M20
b. Output/ Protocol	Analog Output		Digital Protocol
	4-20mA dc		HART Protocol
c. Customer Interface Selections	Indicator	Config Buttons	Languages
	None	None	None
	None	Yes (Zero/Span Only)	None
	Standard (w/internal Zero, Span & Conf Buttons)	None	English
	Standard (w/internal Zero, Span & Conf Buttons)	Yes	English

C__	*
D__	*
G__	*
H__	*
H	*
__0	*
__A	*
__S	*
__T	*

TABLE V	CONFIGURATION SELECTIONS		
a. Application Software	Diagnostics		
	Standard Diagnostics		
b. Output Limit, Failsafe & Write Protect Settings	Write Protect	Fail Mode	High & Low Output Limits ³
	Disabled	High> 21.0mAdc	Honeywell Std (3.8 - 20.8 mAdc)
	Disabled	Low< 3.6mAdc	Honeywell Std (3.8 - 20.8 mAdc)
	Enabled	High> 21.0mAdc	Honeywell Std (3.8 - 20.8 mAdc)
	Enabled	Low< 3.6mAdc	Honeywell Std (3.8 - 20.8 mAdc)
c. General Configuration	Factory Standard		
	Custom Configuration		

1__	*
1	*
2	*
3	*
4	*
__S	*
__C	*

³ NAMUR Output Limits 3.8 - 20.5mAdc can be configured by the customer or select custom configuration Table Vc

TABLE VI CALIBRATION & ACCURACY SELECTIONS			
a. Accuracy and Calibration	Accuracy		Calibrated Range
	Standard		Factory Std
	Standard		Custom (Unit Data Required)
			Calibration Qty
			Single Calibration
			Single Calibration

A	*
B	*

TABLE VII ACCESSORY SELECTIONS			
a. Mounting Bracket	Bracket Type		Material
	None		None
	Flat Pipe Mounting Bracket		Carbon Steel
	Flat Pipe Mounting Bracket		316 SS
	Angle Pipe Mounting Bracket		Carbon Steel
	Angle Pipe Mounting Bracket		316 SS
	Wall Mounting Bracket		Carbon Steel
	Wall Mounting Bracket		316 SS
b. Customer Tag	Customer Tag Type		
	No customer tag		
	One Wired Stainless Steel Tag (Up to 4 lines 26 char/line)		
	Two Wired Stainless Steel Tag (Up to 4 lines 26 char/line)		
One Wired Stainless Steel Blank Tag (Up to 4 lines 26 char/line)			
c. Unassembled Conduit Plugs & Adapters	Unassembled Conduit Plugs & Adapters		
	No Conduit Plugs or Adapters Required		
	1/2 NPT Male to 3/4 NPT Female 316 SS Certified Conduit Adapter		
	1/2 NPT 316 SS Certified Conduit Plug		
	M20 316 SS Certified Conduit Plug		
	Minifast® 4 pin (1/2 NPT) (not suitable for X-Proof applications)		
Minifast® 4 pin (M20) (not suitable for X-Proof applications)			

0	---	*
1	---	*
3	---	*
2	---	*
4	---	*
5	---	*
6	---	*

_ 0 _	---	*
_ 1 _	---	*
_ 2 _	---	*
_ 3 _	---	*

_ _ A0	*
_ _ A2	n
_ _ A6	n
_ _ A7	m
_ _ A8	n
_ _ A9	m

TABLE VIII OTHER CERTIFICATIONS AND OPTIONS	
c. Certifications and Warranty	None - No additional options
	Marine Approval
	Certificate of Conformance
	Calibration Test Report & Certificate of Conformance
	Certificate of Origin
	STL2/3 Certificate
	Extended Warranty Additional 1 year
	Extended Warranty Additional 2 years
	Extended Warranty Additional 3 years
	Extended Warranty Additional 4 years

00	*
MT	d
F3	*
F1	*
F5	*
FE	j
01	*
02	*
03	*
04	*

TABLE IX MANUFACTURING SPECIALS	
Factory	Factory Identification
	0000

0000	*
------	---

MODEL RESTRICTIONS

Restriction Letter	Available Only with		Not Available with	
	Table	Selection(s)	Table	Selection(s)
j			Vb	1,2
d			VIIa	1,3,5,6
m	IVa	D,H, _ _		
n	IVa	C,G, _ _		
b	Select only one option from this group			

FIELD INSTALLABLE REPLACEMENT PARTS

Description	Kit Number
Integrally Mounted Standard Indicator Kit	50126003-501
Single Input Terminal Strip w/Lightning Protection for HART Modules	50086421-513
HART Electronics Module Kit	50086423-501
HART Electronics Module w/connection for external configuration buttons	50086423-502

Kit Number	Price
50126003-501	Note P
50086421-513	Note P
50086423-501	Note P
50086423-502	Note P

Note P - For part number pricing please refer to WEB Channel.

PRODUCT MANUALS

Description	Part Number
Product Manual STT750 Smart Temperature Transmitter User Manual - English	34-TT-25-13
Product Manual STT850/750 Smart Temperature Transmitter Safety Manual - English	34-TT-25-05
Product Manual STT850 Smart Temperature Transmitter HART Communications Manual - English	34-TT-25-15

Part Number
34-TT-25-13
34-TT-25-05
34-TT-25-15

All product documentation is available at www.process.honeywell.com.

Sales and Service

For application assistance, current specifications, pricing, or name of the nearest Authorized Distributor, contact one of the offices below.

ASIA PACIFIC

Honeywell Process Solutions,
(TAC) hfs-tac-support@honeywell.com

Australia
Honeywell Limited
Phone: +(61) 7-3846 1255
FAX: +(61) 7-3840 6481
Toll Free 1300-36-39-36
Toll Free Fax:
1300-36-04-70

China – PRC - Shanghai
Honeywell China Inc.
Phone: (86-21) 5257-4568
Fax: (86-21) 6237-2826

Singapore
Honeywell Pte Ltd.
Phone: +(65) 6580 3278
Fax: +(65) 6445-3033

South Korea
Honeywell Korea Co Ltd
Phone: +(822) 799 6114
Fax: +(822) 792 9015

EMEA

Honeywell Process Solutions,
Phone: + 80012026455 or
+44 (0)1202645583

Email: (Sales)
FP-Sales-Apps@Honeywell.com
or
(TAC)
hfs-tac-support@honeywell.com

Web
Knowledge Base search engine
<http://bit.ly/2N5Vldi>

AMERICA'S

Honeywell Process Solutions,
Phone: (TAC) 1-800-423-9883 or
215/641-3610
(Sales) 1-800-343-0228

Email: (Sales)
FP-Sales-Apps@Honeywell.com
or
(TAC)
hfs-tac-support@honeywell.com

Web
Knowledge Base search engine
<http://bit.ly/2N5Vldi>

Specifications are subject to change without notice.

For more information
To learn more about SmartLine Temperature,
visit www.process.honeywell.com
Or contact your Honeywell Account Manager

Process Solutions
Honeywell
2101 City West Blvd
Houston, TX 77042

Honeywell Control Systems Ltd
Honeywell House, Skimped Hill Lane
Bracknell, England, RG12 1EB
Shanghai City Centre, 100 Jungi Road
Shanghai, China 20061

www.process.honeywell.com

34-TT-03-16
March 2024
©2024 Honeywell International Inc.

Honeywell