

### STG700 SmartLine Gauge Pressure Specification 34-ST-03-102



#### Introduction

Part of the SmartLine® family of products, the STG700 and STG70L are suitable for monitoring, control and data acquisition. STG70X products feature piezoresistive sensor technology combining pressure sensing with on chip temperature compensation capabilities providing high accuracy, stability and performance over a wide range of application pressures and temperatures. The SmartLine family is also fully tested and compliant with Experia<sup>®</sup> PKS providing the highest level of compatibility assurance and integration capabilities. SmartLine easily meets the most demanding application needs for pressure measurement applications.

#### Best in Class Features:

- Accuracy up to 0.065 % of calibrated span
- Stability up to 0.02% of URL per year for five years
- Automatic temperature compensation
- Rangeability up to 100:1
- Response times as fast as 100ms
- Alphanumeric display capabilities
- External zero, span, & configuration capability
- Polarity insensitive electrical connections
- On-board diagnostic capabilities
- Integral Dual Seal design for safety based on ANSI/NFPA 70-202 and ANSI/ISA 12.27.0
- Full compliance to SIL 2/3 requirements as a standard.
- Modular design characteristics

#### Span & Range Limits:

Model	URL/Max Span psi (bar)	LRL psi (bar)	Min Span	Turn down
STG730/STG73L	50 (3.5)	-14.7 (-1.0)	0.5 (0.35)	100:1
STG740/STG74L	500 (35)	-14.7 (-1.0)	5 (.35)	100:1
STG770/STG77L	3000 (210)	-14.7 (-1.0)	30 (2.1)	100:1
STG78L	6000 (420)	-14.7 (-1.0)	60 (4.2)	100:1
STG79L	10000 (690)	-14.7 (-1.0)	100 (6.9)	100:1



Figure 1 – STG700 Gauge Pressure Transmitters feature field-proven piezoresistive sensor technology

#### Communications/Output Options:

- Honeywell Digitally Enhanced (DE)
- HART<sup>®</sup> (version 7.0)
- FOUNDATION<sup>™</sup> Fieldbus

All transmitters are available with the above listed communications protocols.

## Description

The SmartLine family pressure transmitters are designed around a high performance piezo-resistive sensor. This one sensor actually integrates multiple sensors linking process pressure measurement with on-board static pressure (DP Models) and temperature compensation measurements. This level of performance allows the ST 700 to replace most competitive transmitters available today.

## Indication/Display Option

The ST 700 modular design accommodates a basic alphanumeric LCD display.

### Basic Alphanumeric LCD Display Features

- Modular (may be added or removed in the field)
- 0, 90, 180, & 270 degree position adjustments
- Pa, KPa, MPa, KGcm2, Torr, ATM, i4H<sub>2</sub>O, mH<sub>2</sub>O, bar, mbar, inH<sub>2</sub>O, inHG, FTH<sub>2</sub>O, mmH<sub>2</sub>O, mm HG, & psi measurement units
- 2 Lines 16 Characters (4.13H x 1.83W mm)
- Square root output indication ( $\sqrt{\quad}$ )

## Diagnostics

SmartLine transmitters all offer digitally accessible diagnostics which aid in providing advanced warning of possible failure events minimizing unplanned shutdowns, providing **lower overall operational costs**

## Configuration Tools

### Integral Three Button Configuration Option

Suitable for all electrical and environmental requirements, SmartLine offers the ability to configure the transmitter and display via three externally accessible buttons when a display option is selected. Zero/span capabilities are also optionally available via these buttons with or without selection of the display option.

### Hand Held Configuration

SmartLine transmitters feature two-way communication and configuration capability between the operator and the transmitter. This is accomplished via Honeywell's field-rated Multiple Communication Configurator (MCT202).

The MCT202 is capable of field configuring DE and HART Devices and can also be ordered for use in intrinsically safe environments. All Honeywell transmitters are designed and tested for compliance with the offered communication protocols and are designed to operate with any properly validated hand held configuration device.

### Personal Computer Configuration

Honeywell's SCT 3000 Configuration Toolkit provides an easy way to configure Digitally Enhanced (DE) instruments using a personal computer as the configuration interface. Field Device Manager (FDM) Software and FDM Express are also available for managing HART & Fieldbus device configurations.

## System Integration

- SmartLine communications protocols all meet the most current published standards for HART/DE/Fieldbus.
- Integration with Honeywell's Experion PKS offers the following unique advantages.
  - Tamper reporting
  - FDM Plant Area Views with Health summaries
  - All ST 700 units are Experion tested to provide the highest level of compatibility assurance

## Modular Design

To help contain maintenance & inventory costs, all ST 700 transmitters are modular in design supporting the user's ability to replace meter bodies, add indicators or change electronic modules without affecting overall performance or approval body certifications. Each meter body is uniquely characterized to provide in-tolerance performance over a wide range of application variations in temperature and pressure and due to the Honeywell advanced interface, electronic modules may be swapped with any electronics module without losing in-tolerance performance characteristics.

### Modular Features

- Meter body replacement
- Exchange/replace electronics/comms modules\*
- Add or remove integral indicator\*
- Add or remove lightning protection (terminal connection)\*

\* Field replaceable in all electrical environments (including IS) except flameproof without violating agency approvals.

With no performance effects, Honeywell's unique modularity results in **lower inventory needs and lower overall operating costs.**

### Performance Specifications<sup>1</sup>

Reference Accuracy<sup>2</sup>:(conformance to +/-3 Sigma)

Table 1

	Model	URL	LRL	Min Span	Maximum Turndown Ratio	Stability (% URL/Year for five years)	Reference Accuracy (% Span)
Standard Accuracy	STG730	50 psi (3.5 bar)	-14.7 psi (-1.0 bar)	0.5 psi (.035 bar)	100:1	0.03%	0.0650%
	STG73L	50 psi (3.5 bar)	-14.7 psi (-1.0 bar)	0.5 psi (.035 bar)			
	STG740	500 psi (35 bar)	-14.7 psi (-1.0 bar)	5 psi (.35 bar)		0.015%	
	STG74L	500 psi (35 bar)	-14.7 psi (-1.0 bar)	5 psi (.35 bar)			
	STG770	3000 psi (210 bar)	-14.7 psi (-1.0 bar)	30 psi (2.1 bar)		0.03%	
	STG77L	3000 psi (210 bar)	-14.7 psi (-1.0 bar)	30 psi (2.1 bar)			
	STG78L	6000 psi (420 bar)	-14.7 psi (-1.0 bar)	60 psi (4.2 bar)			
	STG79L	10000 psi (690 bar)	-14.7 psi (-1.0 bar)	100 (6.9 bar)			

Zero and span may be set anywhere within the listed (URL/LRL) range limits

Accuracy, Span and Temperature Effect: (Conformance to +/-3 Sigma)

Table 2

	Model	URL	Accuracy <sup>1</sup> (% of Span)			Temperature Effect (% Span/50°F)		
			For Turndowns Greater Than	A	B	C psi (bar)	D	E
Standard Accuracy	STG730	50 psi (3.5 bar)	25:1	0.025	0.04	20 (.14)	0.060	0.005
	STG73L	50 psi (3.5 bar)	12.5:1			4 (.28)		0.010
	STG740	500 psi (35 bar)	25:1			20 (1.4)	0.050	0.007
	STG74L	500 psi (35 bar)	25:1			30 (2.1)		0.010
	STG770	3000 psi (210 bar)	10:1			300 (21)		0.010
	STG77L	3000 psi (210 bar)	10:1			350 (24.2)		0.015
	STG78L	6000 psi (420 bar)	12:1			500 (34.4)	0.050	
	STG79L	10000 psi (690 bar)	10:1			1000 (69)	0.150	0.100
						$\pm \left[ A + B \left( \frac{C}{\text{Span}} \right) \right]$ % Span		$\pm \left[ D + E \left( \frac{\text{URL}}{\text{Span}} \right) \right]$ % Span per 28°C (50°F)

Total Performance (% of Span):

Total Performance Calculation:  $= +/- \sqrt{(\text{Accuracy})^2 + (\text{Temperature Effect})^2}$

Total Performance Examples (for comparison): @ 5:1 Turndown, +/-50 °F (28°C) shift

- |                                   |                                   |
|-----------------------------------|-----------------------------------|
| STG730 @ 100 psi: 0.107% of span  | STG73L @ 100 psi: 0.119% of span  |
| STG740 @ 100 psi: 0.107% of span  | STG74L @ 100 psi: 0.119% of span  |
| STG770 @ 600 psi: 0.119 % of span | STG77L @ 600 psi: 0.141% of span  |
| STG78L @ 1200 psi: 0.307% of span | STG79L @ 2000 psi: 0.653% of span |

Typical Calibration Frequency:

Calibration verification is recommended every two (2) years

Notes:

1. Terminal Based Accuracy - Includes combined effects of linearity, hysteresis, and repeatability. Analog output adds 0 .005% of span.
2. For zero based spans and reference conditions of: 25 °C (77oF), 10 to 55% RH, and 316 Stainless Steel barrier diaphragm.

**Operating Conditions – All Models**

Parameter	Reference Condition		Rated Condition		Operative Limits		Transportation and Storage	
	°C	°F	°C	°F	°C	°F	°C	°F
<b>Ambient Temperature</b> <sup>1</sup>	25±1	77±2	-40 to 85	-40 to 185	-40 to 85	-40 to 185	-55 to 120	-67 to 248
<b>Meter Body Temperature</b> <sup>2</sup>	25±1	77±2	-40 to 110	-40 to 230	-40 to 125	-40 to 257	-55 to 120	-67 to 248
<b>Humidity</b> %RH	10 to 55		0 to 100		0 to 100		0 to 100	
<b>Vac. Region – Min. Pressure</b> mmHg absolute inH <sub>2</sub> O absolute	Atmospheric		25 13		2 (short term) <sup>3</sup> 1 (short term) <sup>3</sup>			
<b>Supply Voltage</b> <b>Load Resistance</b>	10.8 to 42.4 Vdc at terminals 0 to 1,440 ohms (as shown in Figure 2)							
<b>Maximum Allowable Working Pressure (MAWP)</b> <sup>4,5</sup>  (ST700 products are rated to Maximum Allowable Working Pressure. MAWP depends on Approval Agency and transmitter materials of construction.)	STG730: 50 psi (3.5 bar) STG740: 500 psi (35 bar) STG770: 3000 psi (210 bar)		STG73L: 50 psi (3.5 bar ) STG74L: 500 psi (35 bar ) STG77L: 3000 psi (210 bar ) STG78L: 6000 psi (420 bar ) STG79L: 10000 psi (690 bar )					

<sup>1</sup> LCD Display operating temperature -20°C to +70°C Storage temperature -30°C to 80°C.

<sup>2</sup> For CTFE fill fluid, the rating is -15 to 110°C (5 to 230°F)

<sup>3</sup> Short term equals 2 hours at 70°C (158°F)

<sup>4</sup> Units can withstand overpressure of 1.5 x MAWP without damage

<sup>5</sup> Consult factory for MAWP of ST 700 transmitters with CRN approval

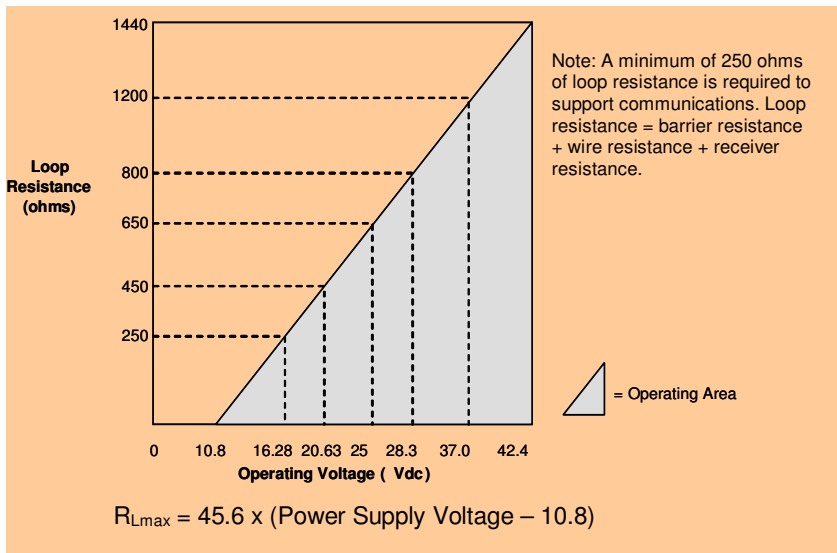

Figure 2 - Supply voltage and loop resistance chart & calculations

**Performance Under Rated Conditions – All Models**

Parameter	Description									
<b>Analog Output</b> <b>Digital Communications:</b>	Two-wire, 4 to 20 mA (HART & DE Transmitters only) Honeywell DE, HART 7 protocol or FOUNDATION Fieldbus ITK 6.0.1 compliant All transmitters, irrespective of protocol have polarity insensitive connection.									
<b>Output Failure Modes</b> (configurable)	<table border="0"> <tr> <td></td> <td style="text-align: center;"><b>Honeywell Standard:</b></td> <td style="text-align: center;"><b>NAMUR NE 43 Compliance:</b></td> </tr> <tr> <td><b>Normal Limits:</b></td> <td style="text-align: center;">3.8 – 20.8 mA</td> <td style="text-align: center;">3.8 – 20.5 mA</td> </tr> <tr> <td><b>Failure Mode:</b></td> <td style="text-align: center;">≤ 3.6 mA and ≥ 21.0 mA</td> <td style="text-align: center;">≤ 3.6 mA and ≥ 21.0 mA</td> </tr> </table>		<b>Honeywell Standard:</b>	<b>NAMUR NE 43 Compliance:</b>	<b>Normal Limits:</b>	3.8 – 20.8 mA	3.8 – 20.5 mA	<b>Failure Mode:</b>	≤ 3.6 mA and ≥ 21.0 mA	≤ 3.6 mA and ≥ 21.0 mA
	<b>Honeywell Standard:</b>	<b>NAMUR NE 43 Compliance:</b>								
<b>Normal Limits:</b>	3.8 – 20.8 mA	3.8 – 20.5 mA								
<b>Failure Mode:</b>	≤ 3.6 mA and ≥ 21.0 mA	≤ 3.6 mA and ≥ 21.0 mA								
<b>Supply Voltage Effect</b>	0.005% span per volt.									
<b>Transmitter Turn on Time</b> (includes power up & test algorithms)	HART or DE: 2.5 sec Foundation Fieldbus: Host dependant									
<b>Response Time</b> (delay + time constant)	<table border="0"> <tr> <td style="text-align: center;"><u><b>DE/HART Protocol</b></u></td> <td style="text-align: center;"><u><b>FOUNDATION Fieldbus</b></u></td> </tr> <tr> <td style="text-align: center;">100ms</td> <td style="text-align: center;">150ms (Host Dependant)</td> </tr> </table>	<u><b>DE/HART Protocol</b></u>	<u><b>FOUNDATION Fieldbus</b></u>	100ms	150ms (Host Dependant)					
<u><b>DE/HART Protocol</b></u>	<u><b>FOUNDATION Fieldbus</b></u>									
100ms	150ms (Host Dependant)									
<b>Damping Time Constant</b>	<b>HART:</b> Adjustable from 0 to 32 seconds in 0.1 increments. <b>Default Value:</b> 0.5 seconds <b>DE:</b> Discrete values 0, 0.16, 0.32, 0.48, 1, 2, 4, 8, 16, 32 seconds. <b>Default Value:</b> 0.48 seconds									
<b>Vibration Effect:</b>	Less than +/- 0.1% of URL w/o damping Per IEC60770-1 field or pipeline, high vibration level (10-2000Hz: 0.21 displacement/3g max acceleration)									
<b>Electromagnetic Compatibility</b>	IEC 61326-3-1									
<b>Lightning Protection Option</b>	<b>Leakage Current:</b> 10uA max @ 42.4VDC 93C <b>Impulse rating:</b> 8/20uS      5000A (>10 strikes)      10000A (1 strike min.) 10/1000uS    200A (> 300 strikes)									

**Materials Specifications** (see model selection guide for availability/restrictions with various models)

Parameter	Description
<b>Barrier Diaphragms Material</b>	<b>STG700:</b> 316L SS, Hastelloy <sup>®</sup> C-276 <sup>2</sup> , Monel <sup>®</sup> 400 <sup>3</sup> , Tantalum <b>STG70L:</b> 316L SS, Hastelloy C-276
<b>Process Head Material</b>	<b>STG700:</b> Carbon Steel (Zinc Plated) <sup>5</sup> , 316 SS <sup>4</sup> , Hastelloy <sup>®</sup> C-276 <sup>6</sup> , Monel <sup>®</sup> 400 <sup>7</sup> <b>STG70L:</b> 316 SS <sup>4</sup>
<b>Vent/Drain Valves &amp; Plugs</b> <sup>1</sup>	<b>STG700:</b> 316 SS <sup>4</sup> , Hastelloy C-276 <sup>2</sup> , Monel 400 <sup>7</sup> <b>STG70L:</b> N/A
<b>Head Gaskets</b>	<b>STG700:</b> Glass-filled PTFE standard. Viton <sup>®</sup> and graphite are optional. <b>STG70L:</b> N/A
<b>Meter Body Bolting</b>	<b>STG700:</b> Carbon Steel (Zinc plated) standard. Options include 316 SS, NACE A286 SS bolts and nuts or NACE A286 SS bolts and 304 SS nuts <b>STG70L:</b> N/A
<b>Mounting Bracket</b>	Carbon Steel (Zinc-plated) or 304 Stainless Steel or 316 Stainless Steel. See Figures 4 & 5
<b>Fill Fluid</b>	Silicone DC <sup>®</sup> 200 oil or CTFE (Chlorotrifluoroethylene).
<b>Electronic Housing</b>	Pure Polyester Powder Coated Low Copper (<0.4%)-Aluminum. Meets NEMA 4X, IP66, IP67 and NEMA 7 (explosion proof). All stainless steel housing is optional.
<b>Process Connections</b>	<b>STG700:</b> ½ -inch NPT (female), DIN 19213 (standard) <b>STG70L:</b> ½ -inch NPT (female), ½ -inch NPT male, 9/16 Aminco, DIN19213 (except STG79L), G½ -B Male Thread
<b>Wiring</b>	Accepts up to 16 AWG (1.5 mm diameter).
<b>Dimensions</b>	See Figures 4 & 5
<b>Net Weight</b>	<b>STG700:</b> 8.3 pounds (3.8 Kg). <b>STG70L:</b> 3.6 pounds (1.6 Kg) with Aluminum Housing

<sup>1</sup> Vent/Drains are sealed with Teflon<sup>®</sup><sup>2</sup> Hastelloy<sup>®</sup> C-276 or UNS N10276<sup>3</sup> Monel<sup>®</sup> 400 or UNS N04400<sup>4</sup> Supplied as 316 SS or as Grade CF8M, the casting equivalent of 316 SS.<sup>5</sup> Carbon Steel heads are zinc-plated and not recommended for water service due to hydrogen migration. For that service, use 316 stainless steel wetted Process Heads.<sup>6</sup> Hastelloy<sup>®</sup> C-276 or UNS N10276. Supplied as indicated or as Grade CW12MW, the casting equivalent of Hastelloy<sup>®</sup> C-276<sup>7</sup> Monel<sup>®</sup> 400 or UNS N04400. Supplied as indicated or as Grade M30C, the casting equivalent of Monel<sup>®</sup> 400

## Communications Protocols & Diagnostics

### HART Protocol

#### Version:

HART 7

#### Power Supply

Voltage: 10.8 to 42.4Vdc at terminals

Load: Maximum 1440 ohms See figure 2

Minimum Load: 0 ohms. (For handheld communications a minimum load of 250 ohms is required)

### Foundation Fieldbus (FF)

#### Power Supply Requirements

Voltage: 9.0 to 32.0Vdc at terminals

Steady State Current: 17.6mAdc

Software Download Current: 27.4mAdc

#### Available Function Blocks

Block Type	Qty	Execution Time
Resource	1	n/a
Transducer	1	n/a
Diagnostic	1	n/a
Analog Input	1*	30 ms
PID w/Autotune	1	45 ms
Integrator	1	30 ms
Signal Char (SC)	1	30 ms
LCD Display	1	n/a
Flow Block	1	30 ms
Input Selector	1	30 ms
Arithmetic	1	30 ms

\* All block may have two (2) additional instantiations.

All available function blocks adhere to FOUNDATION Fieldbus standards. PID blocks support ideal & robust PID algorithms with full implementation of Auto-tuning.

#### Link Active Scheduler

Transmitters can perform as a backup Link Active Scheduler and take over when the host is disconnected.

Acting as a LAS, the device ensures scheduled data transfers typically used for the regular, cyclic transfer of control loop data between devices on the Fieldbus.

#### Number of Devices/Segment

Entity IS model: 6 devices/segment

#### Schedule Entries

18 maximum schedule entries

#### Number of VCR's: 24 max

**Compliance Testing:** Tested according to ITK 6.0.1

### Software Download

Utilizes Class-3 of the Common Software Download procedure as per FF-883 which allows the field devices of any manufacturer to receive software upgrades from any host.

### Honeywell Digitally Enhanced (DE)

DE is a Honeywell proprietary protocol which provides digital communications between Honeywell DE enabled field devices and Hosts.

#### Power Supply

Voltage: 10.8 to 42.4Vdc at terminals

Load: Maximum 1440 ohms See figure 2

### Standard Diagnostics

ST 700 top level diagnostics are reported as either critical or non-critical and readable via the DD/DTM tools or integral display as shown

#### Critical Diagnostics

HART DD/DTM tools	Basic Display
Electronic Module DAC Failure	Electronics Module fault
Meter Body NVM Corrupt	Meterbody fault
Config Data Corrupt	Electronics Module fault
Electronic Module Diag Failure	Electronics Module fault
Meter Body Critical Failure	Meterbody fault
Sensor Comm Timeout	Meterbody Comm fault

#### Non-Critical Diagnostics

HART DD/DTM tools
Display Failure
Electronic Module Comm Failure
Meter Body Excess Correct
Sensor Over Temperature
Fixed Current Mode
PV Out of Range
No Factory Calibration
No DAC Compensation
LRV Set Error – Zero Config Button
URV Set Error – Span Config Button
AO Out of Range
Loop Current Noise
Meter Body Unreliable Comm
Tamper Alarm
No DAC Calibration
Sensor Supply Voltage Low

### Other Certification Options

#### Materials

- NACE MRO175, MRO103, ISO15156

## Approval Certifications:

AGENCY	TYPE OF PROTECTION	COMM. OPTION	FIELD PARAMETERS	AMBIENT TEMP (Ta)
FM Approvals™	<b>Explosionproof:</b> Class I, Division 1, Groups A, B, C, D; <b>Dust Ignition Proof:</b> Class II, III, Division 1, Groups E, F, G; T4  Class I, Zone 0/1, AEx d IIC Ga/Gb T4 Class II, Zone 21, AEx tb IIIC Db T 95°C	All	Note 1	-50 °C to 85°C
	<b>Intrinsically Safe:</b> Class I, II, III, Division 1, Groups A, B, C, D, E, F, G; T4  Class I, Zone 0, AEx ia IIC Ga T4  FISCO Field Device (Only for FF Option) Ex ia IIC T4	4-20 mA / DE/ HART	Note 2a	-50 °C to 70°C
	<b>Nonincendive:</b> Class I, Division 2, Groups A, B, C, D locations,  Class I, Zone 2, AEx nA IIC Gc T4	4-20 mA / DE/ HART/ Foundation Fieldbus	Note 1	-50 °C to 85°C
	<b>Enclosure:</b> Type 4X/ IP66/ IP67	All	All	-
	<b>Explosion Proof:</b> Class I, Division 1, Groups A, B, C, D; <b>Dust Ignition Proof:</b> Class II, III, Division 1, Groups E, F, G; T4  Ex d IIC Ga T4 Ex tb IIIC Db T 95°C	All	Note 1	-50 °C to 85°C
	<b>Intrinsically Safe:</b> Class I, II, III, Division 1, Groups A, B, C, D, E, F, G; T4  Ex ia IIC Ga T4  FISCO Field Device (Only for FF Option) Ex ia IIC T4	4-20 mA / DE/ HART	Note 2a	-50 °C to 70°C
Canadian Standards Association (CSA)	<b>Nonincendive:</b> Class I, Division 2, Groups A, B, C, D; T4  Ex nA IIC Gc T4	4-20 mA / DE/ HART/ Foundation Fieldbus	Note 1	-50 °C to 85°C
	<b>Enclosure:</b> Type 4X/ IP66/ IP67	All	All	-



## Approval Certifications: (Continued)

ATEX	<b>Flameproof:</b> II 1/2 G Ex d IIC Ga/Gb T4 II 2 D Ex tb IIIC Db T 95°C	All	Note 1	-50 °C to 85°C
	<b>Intrinsically Safe:</b> II 1 G Ex ia IIC Ga T4	4-20 mA / DE/ HART	Note 2a	-50 °C to 70°C
	FISCO Field Device (Only for FF Option) Ex ia IIC T4	Foundation Fieldbus	Note 2b	-50 °C to 70°C
	<b>Nonincendive:</b> II 3 G Ex nA IIC Gc T4	4-20 mA / DE/ HART/ Foundation Fieldbus	Note 1	-50 °C to 85°C
	<b>Enclosure:</b> IP66/ IP67	All	All	-
IECEX (World)	<b>Flameproof :</b> Ex d IIC Ga/Gb T4 Ex tb IIIC Db T 95°C	All	Note 1	-50 °C to 85°C
	<b>Intrinsically Safe:</b> Ex ia IIC Ga T4	4-20 mA / DE/ HART	Note 2a	-50 °C to 70°C
	FISCO Field Device (Only for FF Option) Ex ia IIC T4	Foundation Fieldbus	Note 2b	-50 °C to 70°C
	<b>Nonincendive:</b> Ex nA IIC Gc T4	4-20 mA / DE/ HART/ Foundation Fieldbus	Note 1	-50 °C to 85°C
	<b>Enclosure:</b> IP66/ IP67	All	All	-
SAEx (South Africa)	<b>Flameproof :</b> Ex d IIC Ga/Gb T4 Ex tb IIIC Db T 95°C	All	Note 1	-50 °C to 85°C
	<b>Intrinsically Safe:</b> Ex ia IIC Ga T4	4-20 mA / DE/ HART	Note 2a	-50 °C to 70°C
	FISCO Field Device (Only for FF Option) Ex ia IIC T4	Foundation Fieldbus	Note 2b	-50 °C to 70°C
	<b>Nonincendive:</b> Ex nA IIC Gc T4	4-20 mA / DE/ HART/ Foundation Fieldbus	Note 1	-50 °C to 85°C
	<b>Enclosure:</b> IP66/ IP67	All	All	-
INMETRO (Brazil)	<b>Flameproof:</b> Ex d IIC Ga/ Gb T4 Ex tb IIIC Db T 95°C	All	Note 1	T5 Ta = -50 to 93°C
	<b>Intrinsically Safe:</b> Ex ia IIC Ga T4	4-20 mA / DE/ HART	Note 2a	T4 Ta = -50 to 93°C
	FISCO Field Device (Only for FF Option) Ex ia IIC T4	Foundation Fieldbus	Note 2b	T4 Ta = -50 to 70°C
	<b>Nonincendive:</b> Ex nA IIC Gc T4	4-20 mA / DE/ HART/ Foundation Fieldbus	Note 1	-50 °C to 85°C
	<b>Enclosure :</b> IP 66/67	All	All	-



**Approval Certifications: (Continued)**

<b>NEPSI (China)</b>	<b>Flameproof:</b> Ex d IIC Ga/Gb T4 Ex tb IIIC Db T 85°C	All	Note 1	T5 Ta = -50 to 93°C
	<b>Intrinsically Safe:</b> Ex ia IIC Ga T4	4-20 mA / DE/ HART	Note 2a	-50 °C to 70°C
	FISCO Field Device (Only for FF Option) Ex ia IIC T4	Foundation Fieldbus	Note 2b	-50 °C to 70°C
	<b>Nonincendive:</b> Ex nA IIC Gc T4	4-20 mA / DE/ HART/ Foundation Fieldbus	Note 1	-50 °C to 85°C
	<b>Enclosure :</b> IP 66/67	All	All	-
<b>GOST</b>	<b>Flameproof:</b> 1 Ex d IIC Ga/Gb T4 Ex tb IIIC Db T 85°C	All	Note 1	-50 °C to 85°C
	<b>Intrinsically Safe:</b> 0 Ex ia IIC Ga T4	4-20 mA / DE/ HART	Note 2a	-50 °C to 70°C
	FISCO Field Device (Only for FF Option) Ex ia IIC T4	Foundation Fieldbus	Note 2b	-50 °C to 70°C
	<b>Enclosure :</b> IP 66/67	All	All	

**Notes:**

## 1. Operating Parameters:

Voltage= 11 to 42 V DC      Current= 4-20 mA Normal  
= 10 to 30 V (FF)                      = 30 mA (FF)

## 2. Intrinsically Safe Entity Parameters

## a. Analog/ DE/ HART Entity Values:

V<sub>max</sub>= U<sub>i</sub> = 30V      I<sub>max</sub>= I<sub>i</sub>= 105mA      C<sub>i</sub> = 4.2nF      L<sub>i</sub> =984 uH      P<sub>i</sub> =0.9W

Transmitter with Terminal Block Revision E or Later )

V<sub>max</sub>= U<sub>i</sub> = 30V      I<sub>max</sub>= I<sub>i</sub>= 225mA      C<sub>i</sub> = 4.2nF      L<sub>i</sub> = 0      P<sub>i</sub> =0.9W

Note : Transmitter with Terminal Block Revision E or later

The revision is on the label that is on the module. There will be two lines of text on the label:

- First is the Module Part #: 50049839-001 or 50049839-002
- Second line has the supplier information, along with the REVISION:  
XXXXXX-EXXX, THE "X" is production related, THE POSITION of the "E" IS THE REVISION.

## b. Foundation Fieldbus- Entity Values

V<sub>max</sub>= U<sub>i</sub> = 30V      I<sub>max</sub>= I<sub>i</sub>= 180mA      C<sub>i</sub> = 0nF      L<sub>i</sub> = 984 uH      P<sub>i</sub> =1W

Transmitter with Terminal Block Revision F or Later )

V<sub>max</sub>= U<sub>i</sub> = 30V      I<sub>max</sub>= I<sub>i</sub>= 225mA      C<sub>i</sub> =0nF      L<sub>i</sub> = 0      P<sub>i</sub> =1 W

FISCO Field Device      I<sub>max</sub>= I<sub>i</sub>= 380 mA      C<sub>i</sub> = 0nF      L<sub>i</sub> = 0      P<sub>i</sub> =5.32 W

V<sub>max</sub>= U<sub>i</sub> = 17.5V

Note : Transmitter with Terminal Block Revision F or later

The revision is on the label that is on the module. There will be two lines of text on the label:

- First is the Module Part #: 50049839-003 or 50049839-004
- Second line has the supplier information, along with the REVISION:  
XXXXXX-EXXX, THE "X" is production related, THE POSITION of the "E" IS THE REVISION.

**Approval Certifications: (Continued)**

<b>Marine Certificates</b>	<p>This certificate defines the certifications covered for the ST 800 Pressure Transmitter family of products, including the SMV 800 Smart Multivariable Transmitter. It represents the compilation of the five certificates Honeywell currently has covering the certification of these products into marine applications.</p> <p>For ST 800 Smart Pressure Transmitter and SMV800 Smart Multivariable Transmitter</p>
	<p><b>American Bureau of Shipping (ABS)</b> - 2009 Steel Vessel Rules 1-1-4/3.7, 4-6-2/5.15, 4-8-3/13 &amp; 13.5, 4-8-4/27.5.1, 4-9-7/13. Certificate number: 04-HS417416-PDA</p>
	<p><b>Bureau Veritas (BV)</b> - Product Code: 389:1H. Certificate number: 12660/B0 BV</p>
	<p><b>Det Norske Veritas (DNV)</b> - Location Classes: Temperature D, Humidity B, Vibration A, EMC B, Enclosure C. For salt spray exposure; enclosure of 316 SST or 2-part epoxy protection with 316 SST bolts to be applied. Certificate number: A-11476</p>
	<p><b>Korean Register of Shipping (KR)</b> - Certificate number: LOX17743-AE001</p>
	<p><b>Lloyd's Register (LR)</b> - Certificate number: 02/60001(E1) &amp; (E2)</p>
<b>SIL 2/3 Certification</b>	<p>IEC 61508 SIL 2 for non-redundant use and SIL 3 for redundant use according to EXIDA and TÜV Nord Sys Tec GmbH &amp; Co. KG under the following standards: IEC61508-1: 2010; IEC 61508-2: 2010; IEC61508-3: 2010.</p>

**Mounting & Dimensional Drawings)**

Reference Dimensions:  $\frac{\text{millimeters}}{\text{inches}}$

**Mounting Configurations: (Dual head design)**

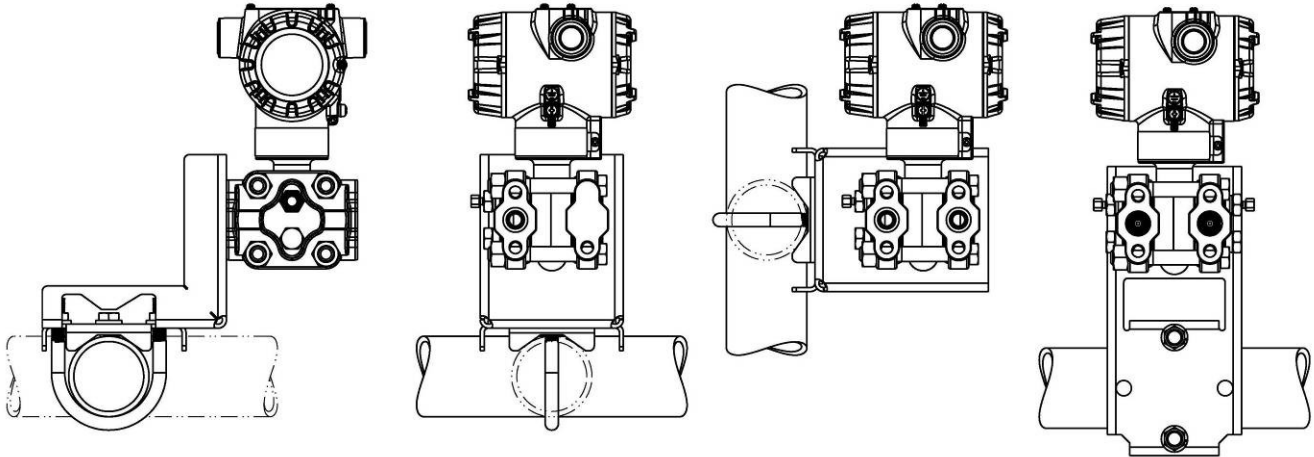

**Dimensions: (Dual head design)**

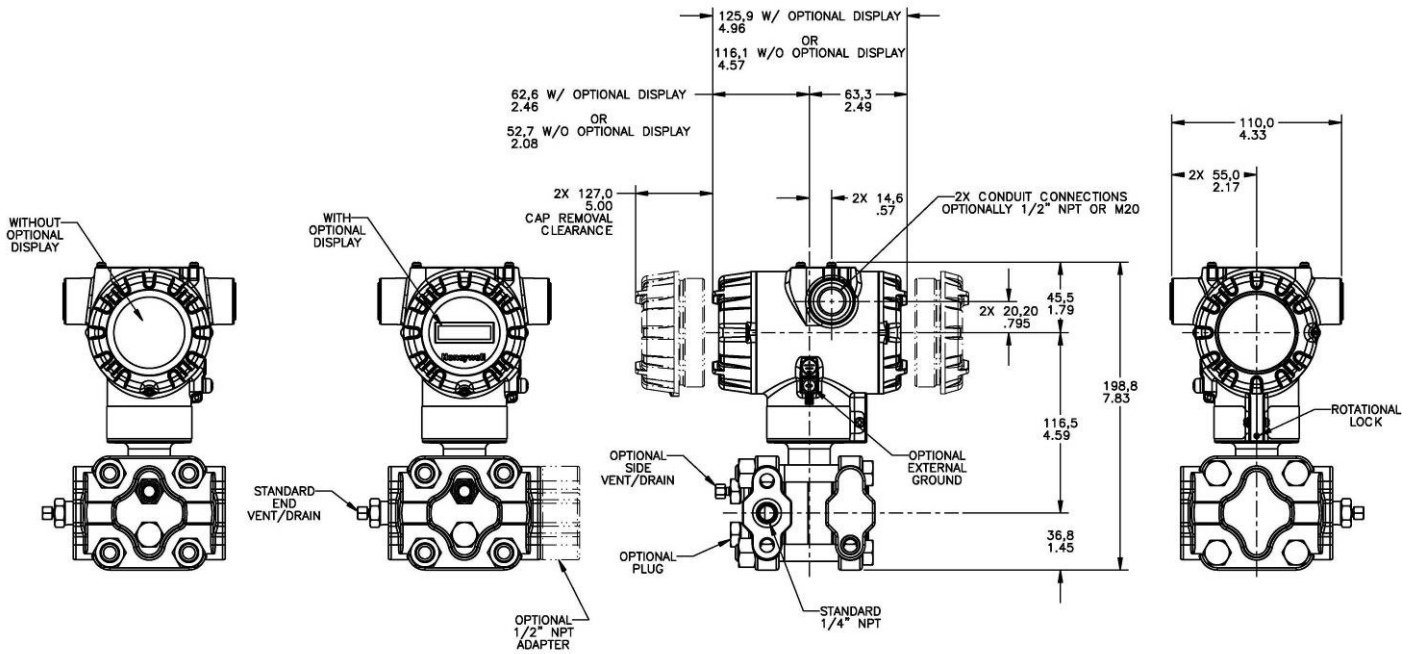
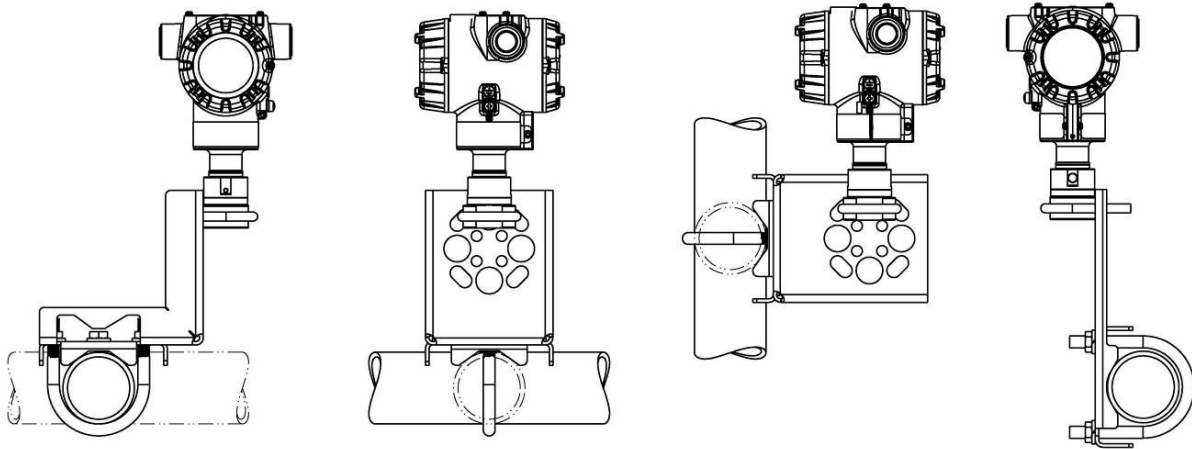

Figure 4 – Typical mounting dimensions of STG740 & STG770 for reference

Reference Dimensions:  $\frac{\text{millimeters}}{\text{inches}}$

**Mounting Configurations (Inline Designs)**



**Dimension (Inline Design)**

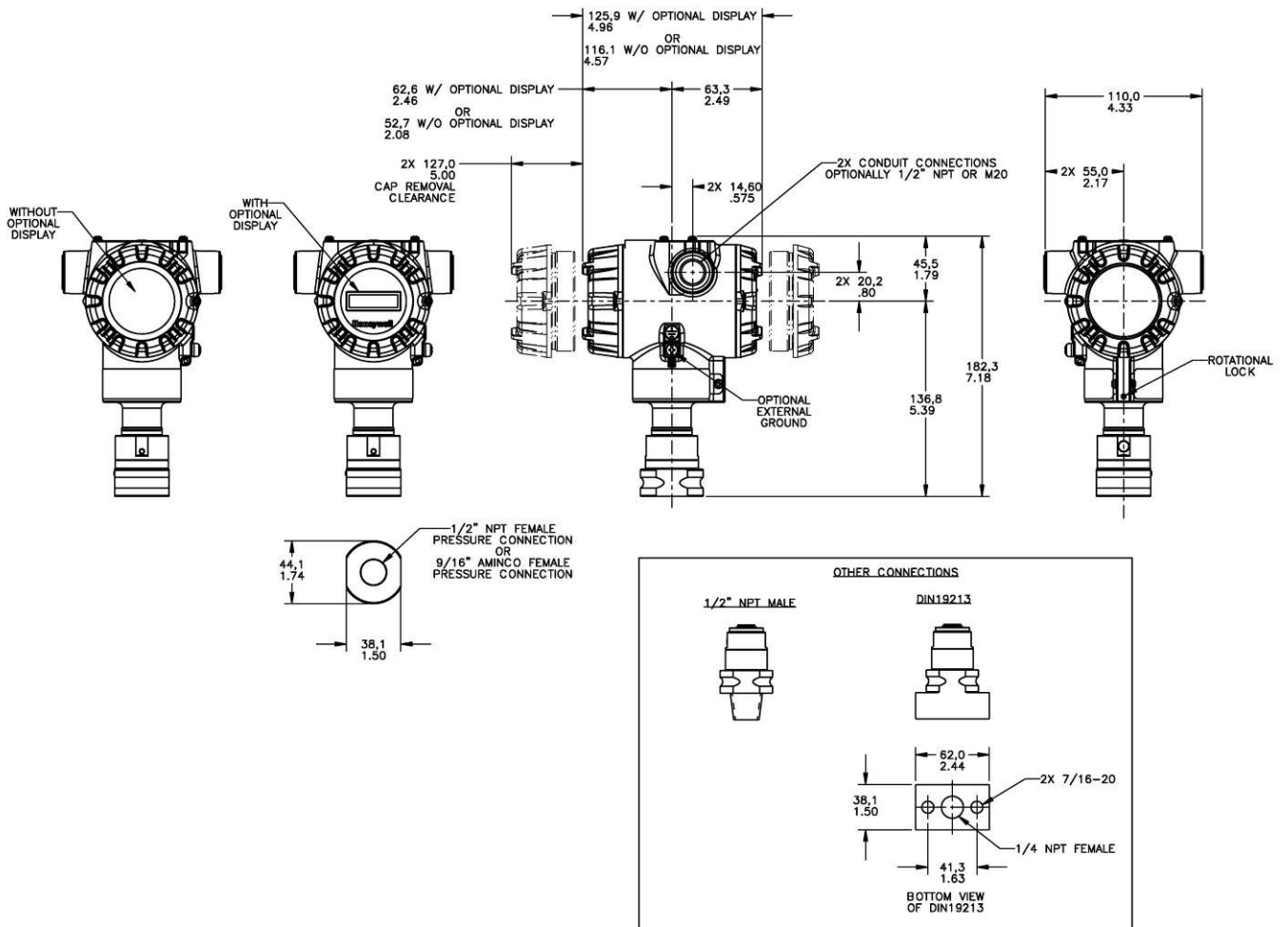

Figure 5 – Typical mounting dimensions of STG74L, STG77L, STG78L, & STG79L for reference

Model Selection Guides are subject to change and are inserted into the specifications as guidance only. Prior to specifying or ordering a model check for the latest revision Model Selection Guides which are published at: [www.honeywellprocess.com/en-US/pages/default.aspx](http://www.honeywellprocess.com/en-US/pages/default.aspx)

**Model Selection Guide**

**Model STG700  
Gauge Pressure Transmitters**

Model Selection Guide  
34-ST-16-102 Issue 4



**Instructions:** Make selections from all Tables using column below the proper arrow. Asterisk indicates availability. Letter (a) refers to restrictions highlighted in the restrictions table. Tables delimited with dashes.

Key STG - I - II - III - IV - V - VI - VII - VIII - IX - 0000

KEY NUMBER	URL/Max Span	LRL	Min Span	Units
Gauge Dual Head	50 (3.5)	-14.7 (-1.0)	0.5 (.035)	psi (bar)
	500 (35)	-14.7 (-1.0)	5 (.35)	psi (bar)
	3000 (210)	-14.7 (-1.0)	30 (2.1)	psi (bar)
Gauge In-Line	50 (3.5)	-14.7 (-1.0)	0.5 (.035)	psi (bar)
	500 (35)	-14.7 (-1.0)	5 (.35)	psi (bar)
	3000 (210)	-14.7 (-1.0)	30 (2.1)	psi (bar)
	6000 (420)	-14.7 (-1.0)	60 (4.2)	psi (bar)
	10000 (690)	-14.7 (-1.0)	100 (6.9)	psi (bar)

Selection	Availability
STG730	↓
STG740	↓
STG770	↓
STG73L	↓
STG74L	↓
STG77L	↓
STG78L	↓
STG79L	↓

TABLE I	METER BODY SELECTIONS			
a. Process Head & Diaphragm Materials	Process Head/Reference Head Material <sup>1b</sup>		Barrier Diaphragm Material	
	Plated Carbon Steel / Plated Carbon Steel		316L SS Hastelloy® C - 276 Monel 400® Tantalum	
	316 Stainless Steel / 316 Stainless Steel		316L SS Hastelloy C - 276 Monel 400 Tantalum	
	Hastelloy C - 276 / 316 Stainless Steel		Hastelloy C - 276 Tantalum	
	Monel 400 /		Monel 400	
b. Fill Fluid	Silicone Oil 200 Fluorinated Oil CTFE			
c. Process Connection	Size/Type		Material	
	9/16" Aminco		Same as Process Head	
	1/2" NPT (female)		Same as Process Head <sup>1a</sup>	
	1/2" NPT (male)		Same as Process Head	
	DIN 19213 (1/4" female NPT) G 1/2 B Threaded Fitting		Same as Process Head	
d. Bolt/Nuts Materials	None Carbon Steel 316 SS Grade 660 (NACE A286) with NACE 304 SS Nuts Grade 660 (NACE A286) Bolts & Nuts Monel K500 Super Duplex B7M			
	Head Type	Vent Type	Location	Vent Material
	None	None	None	None
	Single Ended	None	None	None
	Single Ended	Standard Vent	Side	Matches Head Material <sup>1</sup>
	Single Ended	Center Vent	Side	Stainless Steel Only
Dual Ended	Standard Vent	End	Matches Head Material <sup>1</sup>	
Dual Ended	Center Vent	End	Stainless Steel only	
Dual Ended	Std Vent/Plug	Side/End	Matches Head Material <sup>1</sup>	
f. Gasket Materials	None Teflon® or PTFE (Glass Filled) Viton® Graphite			

A	*	*	*	*
B	*	*	*	*
C	a	a	*	*
D	a	a	*	*
E	*	*	*	*
F	*	*	*	*
G	a	a	*	*
H	a	a	*	*
J	*	*	*	*
K	a	a	*	*
L	a	a	*	*
1	*	*	*	*
2	*	*	*	*

A	*	*	*	*
G	*	*	*	*
H	*	*	*	*
D	*	*	*	*
B	*	*	*	*
0	*	*	*	*
C	*	*	*	*
S	*	*	*	*
N	*	*	*	*
K	p	p	*	*
M	p	p	*	*
D	p	p	*	*
B	*	*	*	*

0	*	*	*	*
1	*	*	*	*
2	*	*	*	*
3	t	t	*	*
4	*	*	*	*
5	t	t	*	*
6	*	*	*	*
0	*	*	*	*
A	*	*	*	*
B	*	*	*	*
C	*	*	*	*

<sup>1</sup> Except Carbon Steel Heads shall use 316SS Vent/Drain & Plugs and or 1/2" adapters

<sup>1a</sup> STG730,740,770 supplied via 1/2" flange adapter same material as process head except carbon steel shall use 316 SS

<sup>1b</sup> Reference head available with Dual Head Gage models only. In-Line Gage models are supplied with Process Head only.

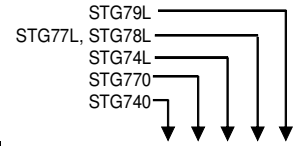

TABLE II Meter Body & Connection Orientation		
Head/Connect Orientation	Standard	High Side Left, Low Side Right <sup>2</sup> / Std Head Orientation
	Reversed	Low Side Left, High Side Right <sup>2</sup> / Std Head Orientation
	90/Standard	High Side Left, Low Side Right <sup>2</sup> / 90° Head Rotation

1	*	*	*	*	*
2	*	*			
3	h	h			

TABLE III AGENCY APPROVALS	
Approvals	No Approvals Required
	<FM> Explosion proof, Intrinsically Safe, Non-incendive, & Dustproof
	CSA Explosion proof, Intrinsically Safe, Non-incendive, & Dustproof
	ATEX Explosion proof, Intrinsically Safe & Non-incendive
	IECEX Explosion proof, Intrinsically Safe & Non-incendive
	SAEx/CCoE Explosion proof, Intrinsically Safe & Non-incendive
	INMETRO Explosion proof, Intrinsically Safe & Non-incendive
NEPSI Explosion proof, Intrinsically Safe & Non-incendive	

0	*	*	*	*	*
A	*	*	*	*	*
B	*	*	*	*	p
C	*	*	*	*	*
D	*	*	*	*	*
E	*	*	*	*	*
F	*	*	*	*	*
G	*	*	*	*	*

TABLE IV TRANSMITTER ELECTRONICS SELECTIONS			
a. Electronic Housing Material & Connection Type	Material	Connection	Lightning Protection
	Polyester Powder Coated Aluminum	1/2 NPT	None
	Polyester Powder Coated Aluminum	M20	None
	Polyester Powder Coated Aluminum	1/2 NPT	Yes
	Polyester Powder Coated Aluminum	M20	Yes
	316 Stainless Steel (Grade CF8M)	1/2 NPT	None
	316 Stainless Steel (Grade CF8M)	M20	None
	316 Stainless Steel (Grade CF8M)	1/2 NPT	Yes
	316 Stainless Steel (Grade CF8M)	M20	Yes
b. Output/ Protocol	Analog Output		Digital Protocol
	4-20mA dc		HART Protocol
	4-20mA dc none		DE Protocol Foundation Fieldbus
c. Customer Interface Selections	Indicator	Ext Zero, Span & Config Buttons	Languages
	None	None	None
	None	Yes (Zero/Span Only)	None
	Basic	None	EN
	Basic	Yes	EN

A __	*	*	*	*	*
B __	*	*	*	*	*
C __	*	*	*	*	*
D __	*	*	*	*	*
E __	*	*	*	*	*
F __	*	*	*	*	*
G __	*	*	*	*	*
H __	*	*	*	*	*

_ H _	*	*	*	*	*
_ D _	*	*	*	*	*
_ F _	*	*	*	*	*

__ 0	*	*	*	*	*
__ A	f	f	f	f	f
__ B	*	*	*	*	*
__ C	*	*	*	*	*

TABLE V CONFIGURATION SELECTIONS			
a. Application Software	Diagnostics		
	Standard Diagnostics		
b. Output Limit, Failsafe & Write Protect Settings	Write Protect	Fail Mode	High & Low Output Limits <sup>3</sup>
	Disabled	High> 21.0mAdc	Honeywell Std (3.8 - 20.8 mAdc)
	Disabled	Low< 3.6mAdc	Honeywell Std (3.8 - 20.8 mAdc)
	Enabled	High> 21.0mAdc	Honeywell Std (3.8 - 20.8 mAdc)
	Enabled	Low< 3.6mAdc	Honeywell Std (3.8 - 20.8 mAdc)
	Enabled	N/A	N/A Fieldbus
Disabled	N/A	N/A Fieldbus	
c. General Configuration	General Configuration		
	Factory Standard Custom Configuration (Unit Data Required from customer)		

1 __	*	*	*	*	*
------	---	---	---	---	---

_ 1 _	f	f	f	f	f
_ 2 _	f	f	f	f	f
_ 3 _	f	f	f	f	f
_ 4 _	f	f	f	f	f
_ 5 _	g	g	g	g	g
_ 6 _	g	g	g	g	g

__ S	*	*	*	*	*
__ C	*	*	*	*	*

<sup>2</sup> Left side/Right side as viewed from the customer connection perspective

<sup>3</sup> NAMUR Output Limits are configurable by customer

TABLE VI CALIBRATION & ACCURACY SELECTIONS			
a. Accuracy and Calibration	Accuracy	Calibrated Range	Calibration Qty
	Standard	Factory Standard	Single Calibration
	Standard	Custom (Unit Data Required)	Single Calibration

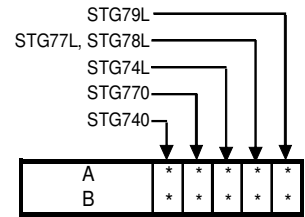

TABLE VII ACCESSORY SELECTIONS		
a. Mounting Bracket	Bracket Type	Material
	None	None
	Angle Bracket	Carbon Steel
	Angle Bracket	304 SS
	Angle Bracket	316 SS
	Marine Approved Angle Bracket	304 SS
	Flat Bracket	Carbon Steel
	Flat Bracket	304 SS
Flat Bracket	316 SS	

0	---	*	*	*	*	*
1	---	*	*	*	*	*
2	---	*	*	*	*	*
3	---	*	*	*	*	*
4	---	*	*	*	*	*
5	---	*	*	*	*	*
6	---	*	*	*	*	*
7	---	*	*	*	*	*

b. Customer Tag	Customer Tag Type	
	No customer tag	
	One Wired Stainless Steel Tag (Up to 4 lines 26 char/line)	
Two Wired Stainless Steel Tag (Up to 4 lines 26 char/line)		

_0	__	*	*	*	*	*
_1	__	*	*	*	*	*
_2	__	*	*	*	*	*

c. Unassembled Conduit Plugs & Adapters	Unassembled Conduit Plugs & Adapters	
	No Conduit Plugs or Adapters Required	
	1/2 NPT Male to 3/4 NPT Female 316 SS Certified Conduit Adapter	
	1/2 NPT 316 SS Certified Conduit Plug	
	M20 316 SS Certified Conduit Plug	
	Minifast® 4 pin (1/2 NPT) (not suitable for X-Proof applications)	
Minifast® 4 pin (M20) (not suitable for X-Proof applications)		

__A0	*	*	*	*	*
__A2	n	n	n	n	n
__A6	n	n	n	n	n
__A7	n	m	m	m	m
__A8	n	n	n	n	n
__A9	m	m	m	m	m

TABLE VIII OTHER Certifications & Options: (String in sequence comma delimited (XX, XX, XX,....))	
Certifications & Warranty	No additional options
	NACE MR0175; MR0103; ISO15156 (FC33338) Process wetted parts only
	NACE MR0175; MR0103; ISO15156 (FC33339) Process wetted and non-wetted parts
	Marine (DNV, ABS, BV, KR, LR) (FC33340)
	EN10204 Type 3.1 Material Traceability (FC33341)
	Certificate of Conformance (F3391)
	Calibration Test Report & Certificate of Conformance (F3399)
	Certificate of Origin (F0195)
	FMEDA (SIL 2/3) Certification (FC33337)
	Over-Pressure Leak Test Certificate (1.5X MAWP) (F3392)
	Cert Clean for O <sub>2</sub> or CL <sub>2</sub> service per ASIM G93

00	*	*	*	*	*
FG	*	*	*	*	*
F7	c	c	c	c	c
MT	d	d	d	d	d
FX	*	*	*	*	*
F3	*	*	*	*	*
F1	*	*	*	*	*
F5	*	*	*	*	*
FE	j	j	j	j	j
TP	*	*	*	*	*
OX	e	e	e	e	e

TABLE IX Manufacturing Specials	
Factory	Factory Identification

0 0 0 0	*	*	*	*	*
---------	---	---	---	---	---

**RESTRICTIONS**

Restriction Letter	Available Only with		Not Available with	
	Table	Selection(s)	Table	Selection(s)
a			VIII	FG, F7
c	ld	___0,N,K,D,B___	I a	C,D,G,H,K,L
d			VIIa	1,2,3,5,6,7
e	lb	_2		
f			IV b	_F_
g			IVb	_H,D
h			le	4, 5, 6
			VIIa	1,2,3,4,5,6,7
j	IV b	H	Vb	1,2,6
m	IV a	B,D,F,H		
n	IV a	A,C,E,G		
p			III	B- No CRN number available
t			Ia	J, K, L
b	Select Only one option from this group			



## Sales and Service

For application assistance, current specifications, pricing, or name of the nearest Authorized Distributor, contact one of the offices below.

### ASIA PACIFIC

Honeywell Process Solutions,  
(TAC) [dfs-tac-support@honeywell.com](mailto:dfs-tac-support@honeywell.com)

#### Australia

Honeywell Limited  
Phone: +(61) 7-3846 1255  
FAX: +(61) 7-3840 6481  
Toll Free 1300-36-39-36  
Toll Free Fax:  
1300-36-04-70

#### China – PRC - Shanghai

Honeywell China Inc.  
Phone: (86-21) 5257-4568  
Fax: (86-21) 6237-2826

#### Singapore

Honeywell Pte Ltd.  
Phone: +(65) 6580 3278  
Fax: +(65) 6445-3033

#### South Korea

Honeywell Korea Co Ltd  
Phone: +(822) 799 6114  
Fax: +(822) 792 9015

### EMEA

Honeywell Process Solutions,  
Phone: + 80012026455 or  
+44 (0)1344 656000

Email: (Sales)

[FP-Sales-Apps@Honeywell.com](mailto:FP-Sales-Apps@Honeywell.com)

or

(TAC)

[dfs-tac-support@honeywell.com](mailto:dfs-tac-support@honeywell.com)

### AMERICA'S

Honeywell Process Solutions,  
Phone: (TAC) 1-800-423-9883 or  
215/641-3610  
(Sales) 1-800-343-0228

Email: (Sales)

[FP-Sales-Apps@Honeywell.com](mailto:FP-Sales-Apps@Honeywell.com)

or

(TAC)

[dfs-tac-support@honeywell.com](mailto:dfs-tac-support@honeywell.com)

*Specifications are subject to change without notice.*

### For more information

To learn more about SmartLine Pressure Transmitters visit [www.honeywellprocess.com](http://www.honeywellprocess.com)  
Or contact your Honeywell Account Manager

### Process Solutions

Honeywell  
1250 W Sam Houston Pkwy S  
Houston, TX 77042

Honeywell Control Systems Ltd  
Honeywell House, Skimped Hill Lane  
Bracknell, England, RG12 1EB

Shanghai City Centre, 100 Jungi Road  
Shanghai, China 20061

[www.honeywellprocess.com](http://www.honeywellprocess.com)

34-ST-03-102  
January 2014

©2014 Honeywell International Inc.

