

# DPR250

## PRODUCT MANUAL





# **DPR 250**

## **DIGITAL STRIP CHART RECORDER**

# **PRODUCT MANUAL**

**Ref. : US1I-6199**



# Copyright, Notices, and Trademarks

© Copyright 2009-10 by Honeywell Inc.

While this information is presented in good faith and believed to be accurate, Honeywell disclaims the implied warranties of merchantability and fitness for a particular purpose and makes no express warranties except as may be stated in its written agreement with and for its customer.

In no event is **Honeywell** liable to anyone for any indirect, special or consequential damages. The information and specifications in this document are subject to change without notice.

This document was prepared using Information Mapping methodologies and formatting principles.

Information Mapping is a trademark of Information Mapping Inc.

Windows is a registered trademark of Microsoft Inc.

Modbus is a registered trademark of MODICON, Inc.

The omission of a name from this list is not to be interpreted that the name is not a trademark.

# About This Document

## Abstract

This manual describes the installation, configuration, operation, and maintenance of the Recorder.

## Warranty

WARRANTY. THE FOLLOWING IS IN LIEU OF ALL OTHER WARRANTIES, EXPRESS OR IMPLIED, INCLUDING THOSE OF MERCHANTABILITY AND FITNESS FOR PARTICULAR PURPOSE.

### a) Goods/Hardware

Except as otherwise hereinafter provided, Honeywell warrants goods of its manufacture to be free of defective materials and faulty workmanship and as conforming to applicable specifications and/or drawings. Commencing with date of shipment, Honeywell's warranty shall run for the period specified on the face hereof or, if none be mentioned, 18 months. If warranted goods are returned to Honeywell during this period of coverage, Honeywell will repair or replace without charge those items it finds defective.

Experimental devices (designated by the letter "X" or "E" within their part-number identification) are prototype, pre-production items that have yet to complete all phases of product-release testing; these items are sold "AS IS" WITH NO WARRANTY.

### b) Software

Software, if listed on the face hereof and used within hardware and/or a system warranted by Honeywell, will be furnished on a medium that's free of defect in materials or workmanship under normal use for so long as the hardware and/or system is under warranty. During this period, Honeywell will replace without charge any such medium it finds defective. As for the quality or performance of any software or data, they are supplied "AS IS" WITH NO WARRANTY.

### c) Services

Where hardware and/or a system is installed by Honeywell, such services are warranted against faulty workmanship for the same period (if any) as applies to the installed items. During this concurrently running period, Honeywell will correct without charge any workmanship it finds to be faulty.

## Contacts

If you encounter any problem with your recorder, please contact your nearest Sales Office. (See the address list at the end of this manual).

An engineer will discuss your problem with you. **Please have your complete model number and serial number available.** Model number and serial number are located on the chassis nameplate.

If it is determined that a hardware problem exists, a replacement instrument or part will be shipped with instructions for returning the defective unit. Do not return your instrument without authorization from your Sales Office or until the replacement has been received.





**World Wide Web:** <http://www.honeywell.com>

**Corporate Industrial Measurement and Control:** <http://www.honeywell.com/imc/>

Telephone: USA & Canada Honeywell:

**Technical Support:** 1800-423-9883  
**TAC FACS:** 1888-423-9883  
**Service:** 1800-525-7439

## Symbol Meanings

Symbol	What it means
	Protective ground terminal. Provided for connection of the protective earth green (green or green/yellow) supply system conductor.
	Functional ground terminal. Used for non-safety purposes such as noise immunity improvement.
	WARNING. Risk of electric shock. This symbol warns the user of a potential shock hazard where voltages greater than 30 Vrms, 42.4 Vpeak, or 60 Vdc may be accessible.
	CAUTION. When this symbol appears on the product, see the user manual for more information. This symbol appears next to the required information in the manual.

### CE conformity

This product conforms with the protection requirements of the following European Council Directives: 89/336/EEC, the EMC directive, and 73/23/EEC, the low voltage directive. Do not assume this product conforms with any other “CE Mark” Directive(s).

### Attention

The emission limits of EN 61326-1 are designed to provide reasonable protection against harmful interference when this equipment is operated in an industrial environment. Operation of this equipment in a residential area may cause harmful interference. This equipment generates, uses, and can radiate radio frequency energy and may cause interference to radio and television reception when the equipment is used closer than 30 meters to the antenna(e). In special cases, when highly susceptible apparatus is used in close proximity, the user may have to employ additional mitigating measures to further reduce the electromagnetic emissions of this equipment.

Product model number:	
Serial number:	
Date code:	
Service department telephone number:	





## TABLE OF CONTENTS

1.	OVERVIEW .....	1-1
1.1	RECORDER OVERVIEW .....	1-2
1.2	MODEL SELECTION GUIDE .....	1-4
2.	INSTALLATION .....	2-1
2.1	WARNING .....	2-2
2.2	UNPACKING .....	2-3
2.3	PANEL MOUNTING THE RECORDER .....	2-4
2.4	WIRING THE RECORDER.....	2-7
2.5	TERMINAL CONNECTIONS .....	2-8
2.6	FITTING THE CHART .....	2-15
2.7	INSTALLING THE PRINTING SYSTEM.....	2-22
2.8	CHECK LIST .....	2-24
3.	OPERATION .....	3-1
3.1	OPERATOR INTERFACE EXPLANATIONS .....	3-2
3.2	OPERATOR INTERFACE.....	3-2
3.3	POWER UP .....	3-3
3.4	SELECTING AND INTERPRETING RUN MODE DISPLAY.....	3-4
3.5	OPERATOR INITIATED ACTIONS.....	3-9
3.6	GLOSSARY OF OPERATING TERMS .....	3-12
4.	CONFIGURATION.....	4-1
4.1	INTRODUCTION.....	4-2
4.2	PARAMETERS LIST.....	4-3
4.3	PRINCIPLES OF CONFIGURATION .....	4-4
4.4	COPY CONFIGURATION.....	4-104
4.5	PRINT CONFIGURATION.....	4-108
4.6	CONFIGURABLE AND PRINTABLE CHARACTERS.....	4-114
	INDEX.....	4-115
5.	PC CONFIGURATION.....	5-2
5.1	OVERVIEW .....	5-2
5.2	INSTALLING THE SOFTWARE ON YOUR SYSTEM.....	5-2
5.3	INSTALLING THE FIRMWARE ON THE RECORDER FOR COMMS .....	5-3
5.4	PC - RECORDER INTERFACE.....	5-3
5.5	CONFIGURATION UPLOAD/DOWNLOAD.....	5-4
5.6	RECORDER FIRMWARE UPGRADE .....	5-8
5.7	COMMUNICATION FIRMWARE UPGRADE .....	5-8
5.8	RELAY STATE AND CONTROL.....	5-8
5.9	COPY LINE OPERATION.....	5-9
5.10	USER ACTUATION.....	5-9

# TABLE OF CONTENTS

---

6.	KITS LIST.....	6-1
7.	TROUBLESHOOTING .....	7-1
	7.1 PARTS LOCATION.....	7-2
	7.2 SYMPTOMS: .....	7-4
	to 7.24.....	7-10
8.	SERVICE.....	8-1
	8.1 OPERATOR INTERFACE.....	8-2
	8.2 LIST OF SERVICES.....	8-5
9.	PRODUCT SPECIFICATION .....	9-1
10.	PROMPTS TRANSLATION .....	10-1
	10.1 MATRICES .....	10-2
11.	CONFIGURATION WORKSHEETS .....	11-1
	to 11.13.....	11-16

SAFETY TRANSLATIONS

SALES AND SERVICE

**TABLE OF CONTENTS**

**Section 1**

1.1 RECORDER OVERVIEW ..... 1-2

    1.1.1 INTRODUCTION .....1-2

    1.1.2 MODEL SELECTION GUIDE ..... 1-3

## 1.1 RECORDER OVERVIEW

### 1.1.1 INTRODUCTION

This recorder is a precision measuring instrument that offers many features.

- Up to 64 analog input channels,
- Compact size: 320 mm (12.60 ") depth,  
310 mm front face height x 387 mm width (12.21 " x 15.24 " ),  
278 mm x 348 mm (10.95 " x 13.70 ") cutout,
- 250 mm chart in either roll or fanfold presentation,
- Universal power supply: 100 to 240 V ac/dc,
- IP55 front panel protection,
- Universal input with a wide choice of actuation/range,
- Option linear input,
- High accuracy: 0.05 % via field calibration,
- Easy interactive product configuration,
- Large, clear operator display,
- Fast scanning rate:

2 channels = 105 ms	24 channels = 1260 ms	48 channels = 2520 ms
4 channels = 210 ms	28 channels = 1470 ms	52 channels = 2730 ms
8 channels = 420 ms	32 channels = 1680 ms	56 channels = 2940 ms
12 channels = 630 ms	36 channels = 1890 ms	60 channels = 3150 ms
16 channels = 840 ms	40 channels = 2100 ms	64 channels = 3360 ms
20 channels = 1050 ms	44 channels = 2310 ms	52 channels = 2730 ms
- Configurable alphanumeric chart documentation,
- Up to 64 alarm setpoints with a wide choice of alarm types,
- Event alarm: End of chart paper, sensor burnout, clock battery low, etc.,
- Up to 64 customer messages of 64 characters each,
- Standard chart illumination,
- Product configuration, service diagnostic, software upgrading via PC interface,
- Chart zoning configurable,
- Complies with IEC348 and EN61010-1 safety requirements,
- EC mark: Conformity with 73/23/EEC low voltage directive and 89/336 EEC, EMC directives,
- CSA approval (certified) LR57938

#### OPTIONS:

- Up to 48 alarm relay outputs,
- Up to 48 digital inputs,
- Keylock,
- 32 Maths functions,
- Communication board,
- Up to 8 4/20 mA current outputs,
- PCMCIA board driver.

## 1.2 MODEL SELECTION GUIDE

This table helps you to identify correctly the unit in front of you. Please refer to the product label and verify that you have the right unit.

Select the desired key number. The mark to the right shows the selection available. A complete model number has the requested number of digits from each table as follows:

### Instructions

- Select the desired Key Number. The arrow to the right marks the selection available.
- A dot denotes unrestricted availability. A letter denotes restricted availability.
- A complete Model Number must have the designated number of digits in each table.

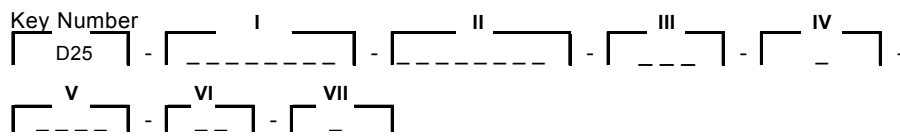

### KEY NUMBER

Description		
250 mm Strip Chart Recorder	D25	↓

TABLE I - Lower Rack Analog Inputs

		Selection	Availability
Input Card 1 (Slot A)	None 4 Linear Inputs (Channel 1 to 4) 4 Universal Inputs (Channel 1 to 4)	0 _____ L _____ U _____	• • •
Input Card 2 (Slot B)	None 4 Linear Inputs (Channel 5 to 8) 4 Universal Inputs (Channel 5 to 8)	_ 0 _____ _ L _____ _ U _____	• • •
Input Card 3 (Slot C)	None 4 Linear Inputs (Channel 9 to 12) 4 Universal Inputs (Channel 9 to 12)	_ _ 0 _____ _ _ L _____ _ _ U _____	• • •
Input Card 4 (Slot D)	None 4 Linear Inputs (Channel 13 to 16) 4 Universal Inputs (Channel 13 to 16)	_ _ _ 0 _____ _ _ _ L _____ _ _ _ U _____	• • •
Input Card 5 (Slot E)	None 4 Linear Inputs (Channel 17 to 20) 4 Universal Inputs (Channel 17 to 20)	_ _ _ _ 0 ____ _ _ _ _ L ____ _ _ _ _ U ____	• • •
Input Card 6 (Slot F)	None 4 Linear Inputs (Channel 21 to 24) 4 Universal Inputs (Channel 21 to 24)	_ _ _ _ _ 0 _ _ _ _ _ _ L _ _ _ _ _ _ U _	• • •
Input Card 7 (Slot G)	None 4 Linear Inputs (Channel 25 to 28) 4 Universal Inputs (Channel 25 to 28)	_ _ _ _ _ 0 _ _ _ _ _ _ L _ _ _ _ _ _ U _	• • •
Input Card 8 (Slot H)	None 4 Linear Inputs (Channel 29 to 32) 4 Universal Inputs (Channel 29 to 32)	_ _ _ _ _ 0 _ _ _ _ _ L _ _ _ _ _ U	• • •

# 1. OVERVIEW

**TABLE II - Upper Rack Digital Inputs/Outputs**

Analog Inputs/Outputs		Selection	Availability D25
Slot J	None	0 _____	•
	4 Linear Inputs (Channel 33 to 36)	L _____	•
	4 Universal Inputs (Channel 33 to 36)	U _____	•
	6 Alarm Relay Outputs (Alarm 1 to 6)	A _____	•
	6 Digital Inputs (Digital 1 to 6)	D _____	•
Slot K	None	_ 0 _____	•
	4 Linear Inputs (Channel 37 to 40)	_ L _____	•
	4 Universal Inputs (Channel 37 to 40)	_ U _____	•
	6 Alarm Relay Outputs (Alarm 7 to 12)	_ A _____	•
	6 Digital Inputs (Digital 7 to 12)	_ D _____	•
Slot L	None	__ 0 _____	•
	4 Linear Inputs (Channel 41 to 44)	__ L _____	•
	4 Universal Inputs (Channel 41 to 44)	__ U _____	•
	6 Alarm Relay Outputs (Alarm 13 to 18)	__ A _____	•
	6 Digital Inputs (Digital 13 to 18)	__ D _____	•
Slot M	None	___ 0 _____	•
	4 Linear Inputs (Channel 45 to 48)	___ L _____	•
	4 Universal Inputs (Channel 45 to 48)	___ U _____	•
	6 Alarm Relay Outputs (Alarm 19 to 24)	___ A _____	•
	6 Digital Inputs (Digital 19 to 24)	___ D _____	•
Slot N	None	____ 0 _____	•
	4 Linear Inputs (Channel 49 to 52)	____ L _____	•
	4 Universal Inputs (Channel 49 to 52)	____ U _____	•
	6 Alarm Relay Outputs (Alarm 25 to 30)	____ A _____	•
	6 Digital Inputs (Digital 25 to 30)	____ D _____	•
Slot P	None	_____ 0 _____	•
	4 Linear Inputs (Channel 53 to 56)	_____ L _____	•
	4 Universal Inputs (Channel 53 to 56)	_____ U _____	•
	6 Alarm Relay Outputs (Alarm 31 to 36)	_____ A _____	•
	6 Digital Inputs (Digital 31 to 36)	_____ D _____	•
Slot Q	None	_____ 0 _____	•
	4 Linear Inputs (Channel 57 to 60)	_____ L _____	•
	4 Universal Inputs (Channel 57 to 60)	_____ U _____	•
	6 Alarm Relay Outputs (Alarm 37 to 42)	_____ A _____	•
	6 Digital Inputs (Digital 37 to 42)	_____ D _____	•
	4 Current Outputs (Output 1 to 4)	_____ C _____	•
Slot R	None	_____ 0 _____	•
	4 Linear Inputs (Channel 61 to 64)	_____ L _____	•
	4 Universal Inputs (Channel 61 to 64)	_____ U _____	•
	6 Alarm Relay Outputs (Alarm 43 to 48)	_____ A _____	•
	6 Digital Inputs (Digital 43 to 48)	_____ D _____	•
4 Current Outputs (Output 5 to 8)	_____ C _____	•	

# 1. OVERVIEW

		Selection	D25
Communications	None	0 __	•
	Universal Communication (RS232/422/485) ASCII/Modbus RTU	1 __	•
	Ethernet Interface	2 __	d
PCMCIA	None	_ 0 _	•
	PCMCIA Interface (Note 6)	A	•
Math	None	_ _ 0	•
	Math Package	_ _ A	•

Grey Door, Glass Window, with Latch, Standard Case	0	•
Grey Door, Glass Window, with Key Lock, Standard Case	1	•
Grey Door, Plastic Window, with Latch, Standard Case	2	•
Grey Door, Plastic Window, with Key Lock, Standard Case	3	•
Grey Door, Glass Window, with Latch, Black Case	A	•
Grey Door, Glass Window, with Key Lock, Black Case	B	•
Grey Door, Plastic Window, with Latch, Black Case	C	•
Grey Door, Plastic Window, with Key Lock, Black Case	D	•
Black Door, Glass Window, with Latch, Black Case	E	•
Black Door, Glass Window, with Key Lock, Black Case	F	•

None	0 _ _ _	•
None	_ 0 _ _	•
Test Report (Calibration Certificate) (Note 5)	_ A _ _	•
Certificate of Conformance	_ B _ _	•
None	_ _ 0 _	•
Product Configuration (Note 3)	_ _ A _	•
Product Configuration with User Defined Actuation (Note 3)	_ _ B _	•
User Defined Actuation (Note 3)	_ _ U _	•
None	_ _ _ 0	•
CSA Approval/NRTL/C (Note 4)	_ _ _ C	•

None	00	•
Special ST # (Consult Ft. Washington)	XX	•

Product Information on CD	0	•
English	E	•
French	F	•
German	G	•
Italian Prompts/English Manual	I	•
Spanish	S	•







### TABLE OF CONTENTS

Section	Page
2.1	WARNING ..... 2-2
2.2	UNPACKING ..... 2-3
2.3	PANEL MOUNTING THE RECORDER ..... 2-4
2.3.1	Recommendations ..... 2-4
2.3.2	External dimensions and cut-out ..... 2-4
2.3.3	Installing the recorder ..... 2-5
2.4	WIRING THE RECORDER ..... 2-7
2.4.1	Recommendations ..... 2-7
2.5	TERMINAL CONNECTIONS ..... 2-8
2.5.1	Digital input signals. (DI). ..... 2-10
2.5.2	Relay outputs. (DO). ..... 2-11
2.5.2.1	<i>Removing the alarm card to change NC to NO contacts</i> ..... 2-12
2.6	FITTING THE CHART ..... 2-15
2.6.1	Chart cassette ..... 2-16
2.6.2	Cleaning the rod and lubricating the carriage bushings. .... 2-21
2.7	INSTALLING THE PRINTING SYSTEM ..... 2-22
2.8	CHECK LIST ..... 2-24

## 2. INSTALLATION

### 2.1 WARNING

WARNING	
IMPROPER INSTALLATION	
	To avoid the risk of electrical shock that could cause personal injury, follow all safety notices in this documentation.
	Protective earth terminal. Provided for connection of the protective earth supply system conductor.
<b>Failure to comply with these instructions could result in death or serious injury</b>	

**POWER SUPPLY**

Ensure the source voltage matches the voltage of the power supply before turning on the power. (In the rear of the recorder, near to the connector of the power supply)

**PROTECTIVE GROUNDING**

Make sure to connect the protective grounding to prevent an electric shock before turning on the power. Do not operate the instrument when protective grounding or fuse might be defective. To avoid a potential shock hazard, never cut off the internal or external grounding wire or disconnect the protective grounding terminal

**NECESSITY OF PROTECTIVE GROUNDING**

To avoid a potential shock hazard, never cut off the internal or external protective grounding wire or disconnect the wiring of protective grounding terminal.

**FUSE**

To prevent a fire, make sure to use the fuse with specified standard (current voltage, type). Before replacing the fuse, turn off the power and disconnect the power source. Do not use a different fuse or short-circuit the fuse holder.

**DO NOT OPERATE IN AN EXPLOSIVE ATMOSPHERE**

Do not operate the instrument in the presence of flammable liquids or vapours. Operation of any electrical instrument in such an environment constitutes a safety hazard.

**NEVER TOUCH THE INTERIOR OF THE INSTRUMENT**

Inside this instrument there are areas of high voltage; therefore, never touch the interior if the power supply is connected. This instrument has an internal changeable system; however, internal inspection and adjustments should be performed by qualified personnel only.

If the equipment is used in a manner not specified by the manufacturer, the protection provided by the equipment may be impaired.

Do not replace any component (or part) not explicitly specified as replaceable by your supplier.

**INSTALL INDOOR ONLY**

## 2. INSTALLATION

### 2.2 UNPACKING

Remove the accessories and check them against the figure below.

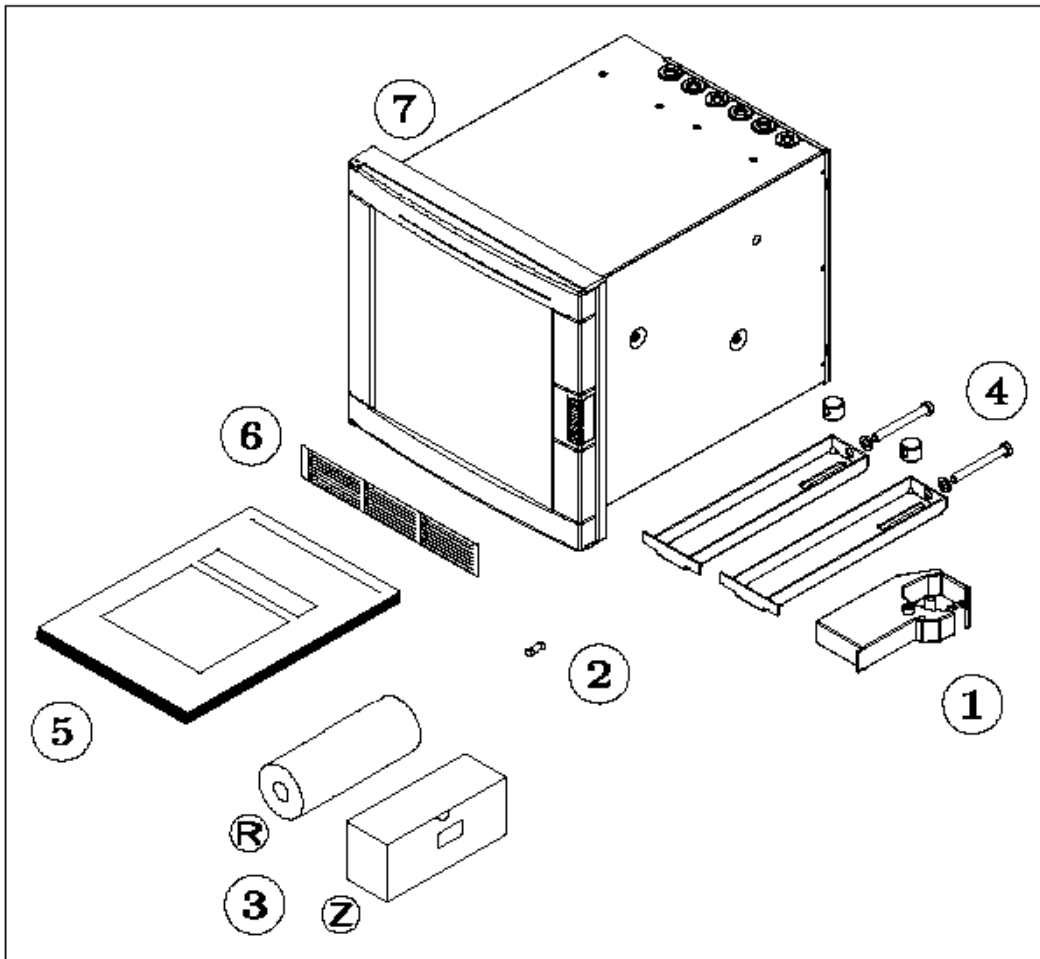

- |  |                                |
|--|--------------------------------|
| 1. Ribbon cartridge  | 4. Mounting brackets with nuts |
| 2. Fuse (Spare) (Use only 3.15 A T. fuses for Europe or 3.2 A T. fuses for U.S.) | 5. Product manual or CD        |
| 3. Roll (R) and fanfold (Z) chart  | 6. Front label                 |
| 7.   | Recorder                       |

**NOTE:** In the event that any items are missing, please contact your nearest sales office.



## 2. INSTALLATION

### 2.3.3 Installing the recorder

To install the recorder, follow the figures below:

1. Remove rear cover and wire access holes.
2. Insert recorder through the panel cutout
3. Attach mounting brackets to the sides of the recorder
4. Tighten the mounting screws

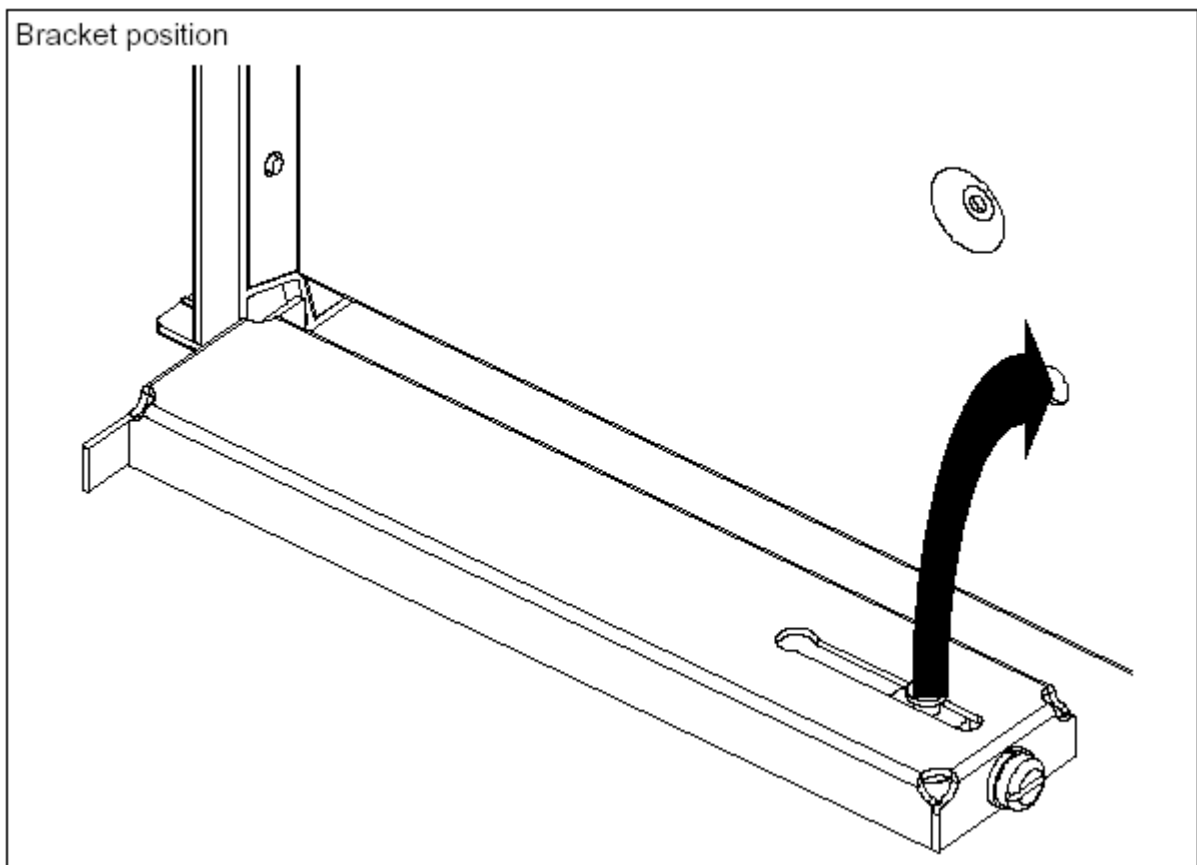

## 2. INSTALLATION

Mounting brackets

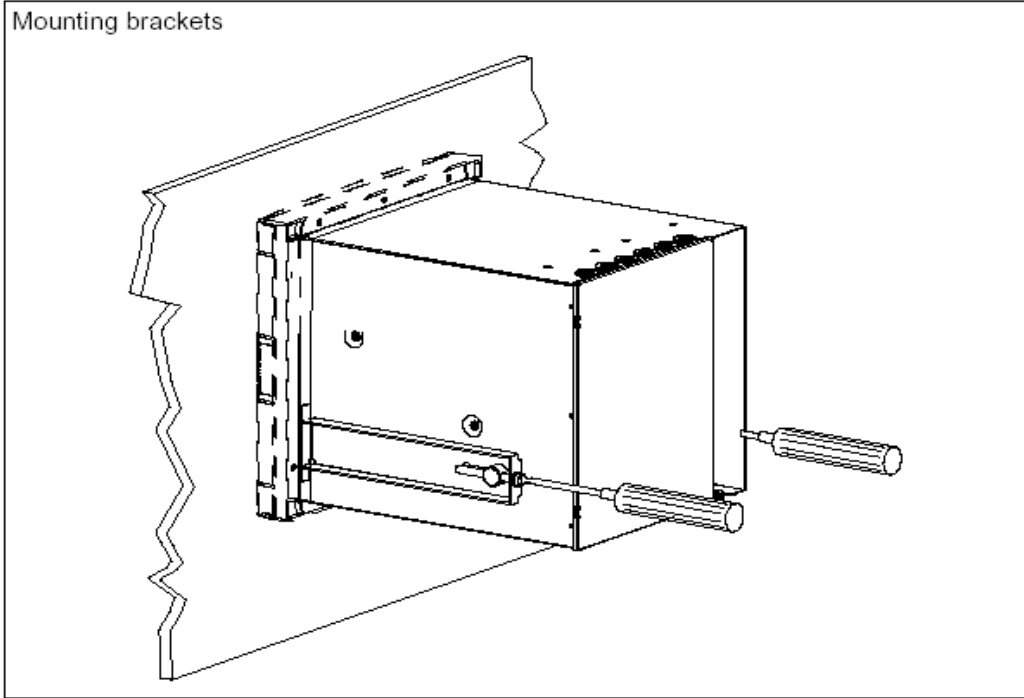

Mounting angle limits

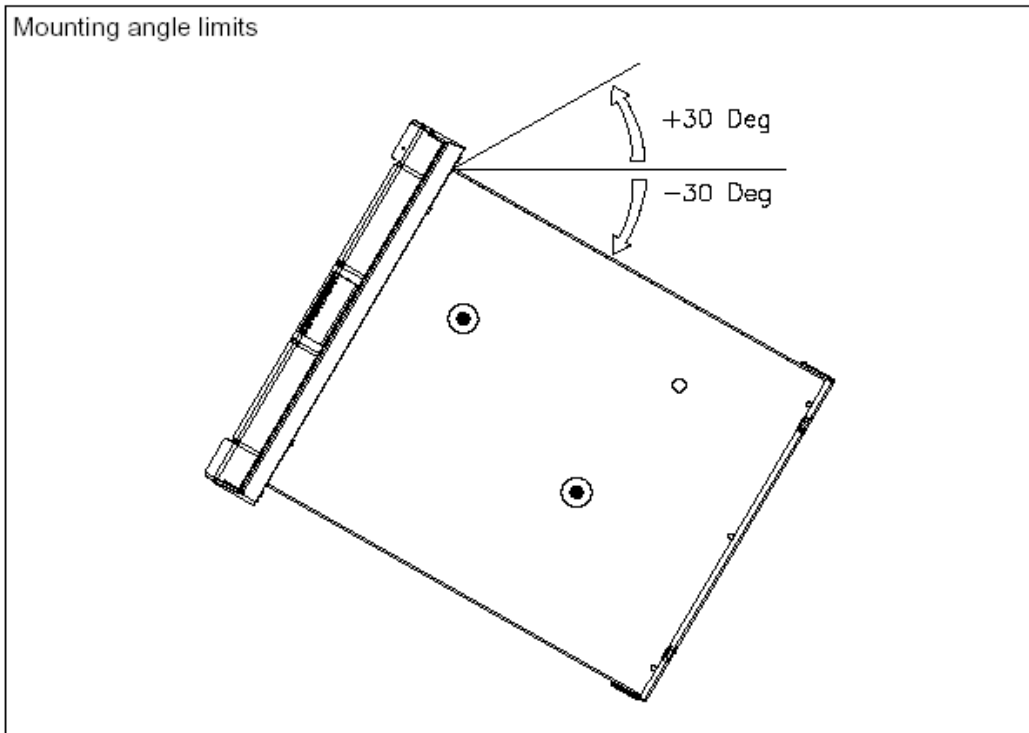

### 2.4 WIRING THE RECORDER

#### 2.4.1 Recommendations

- All wiring must be in accordance with local electrical codes and should be carried out by authorized experienced personnel.
- **The ground terminal must be connected before any other wiring (and disconnected last).**
- **A switch in the main supply is recommended near the equipment.**
- **If an external fuse is used to protect the electrical circuit to the recorder, the fuse should match the recorder fuse rating (fuse type) as well as for the fuse holder.**
- Sensor wiring should be run as far as possible from power wiring. (motors, contactors, alarms, etc.)
- To reduce stray pick-up, we recommend the use of a twisted pair sensor wiring.
- **EMI effects can be further reduced by the use of shielded cable sensor wiring. The shield must be connected to the ground terminal.**
- The use of spade terminals on all wiring is recommended.

## 2. INSTALLATION

### 2.5 TERMINAL CONNECTIONS

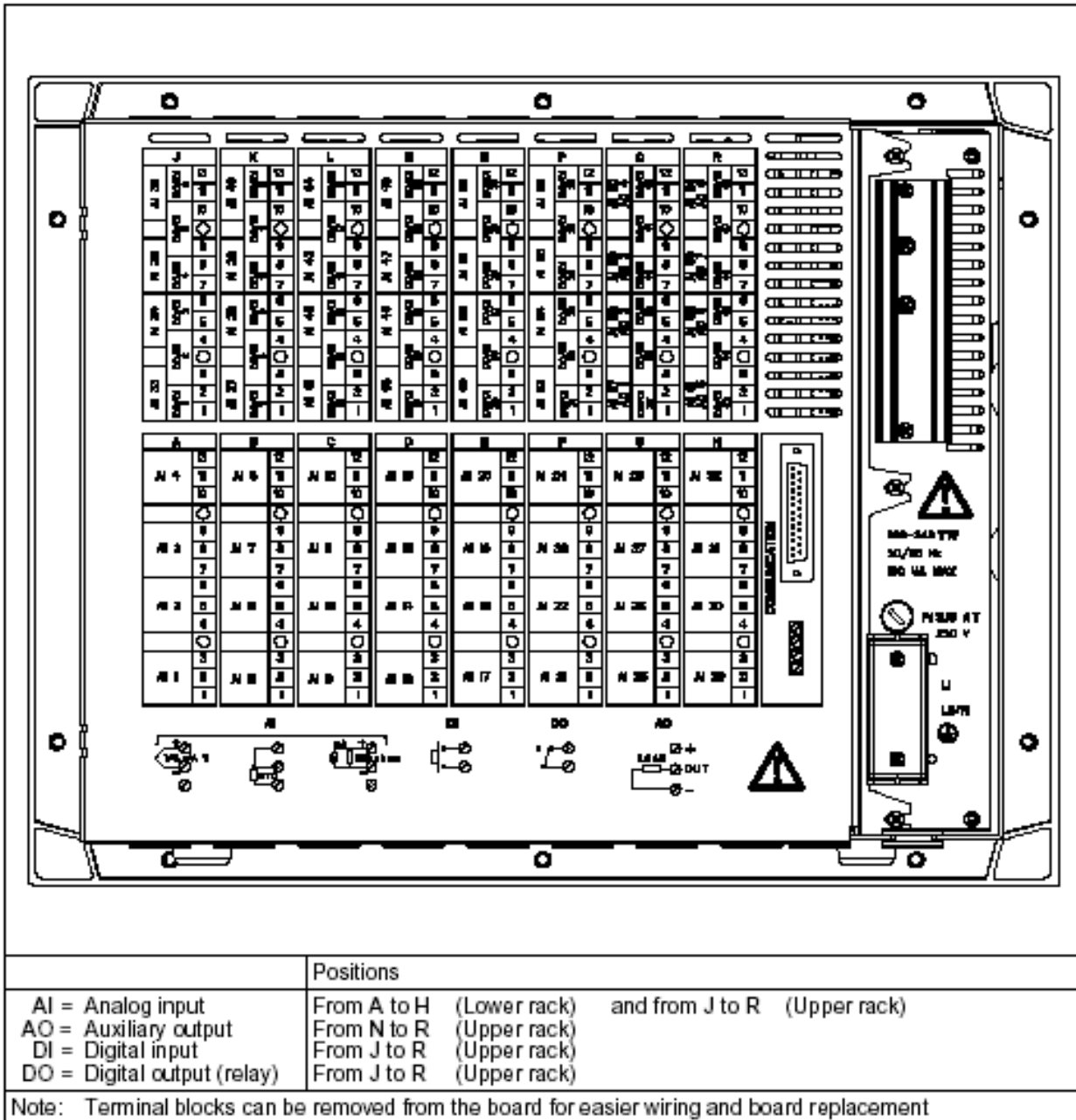



## 2. INSTALLATION

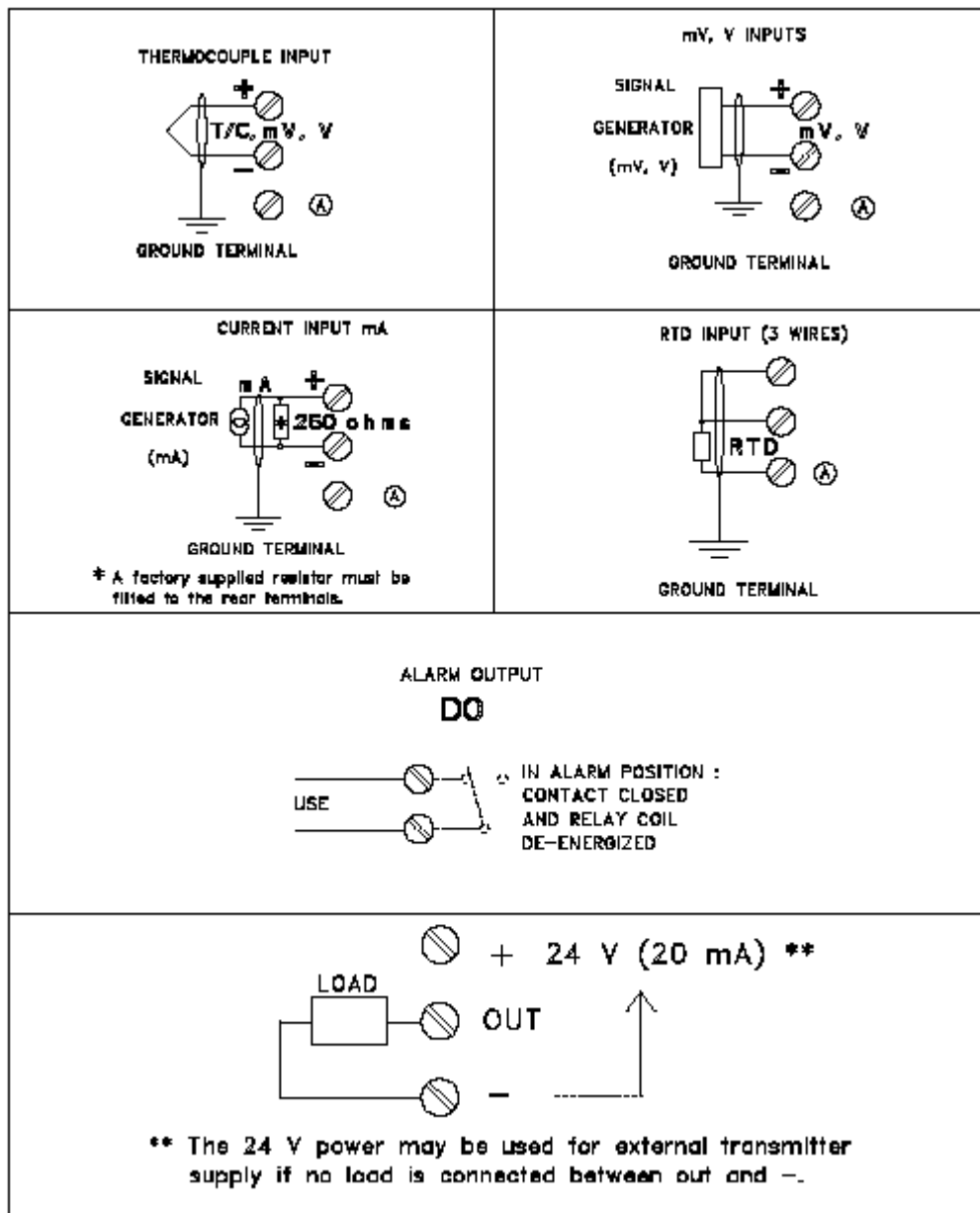

**Note:** Terminal (A) is only used for RTD. (See diagrams above)



### CAUTION

Unwired configured channel terminals should be shorted.

**Failure to comply with these instructions may result in product damage**

## 2. INSTALLATION

### 2.5.1 Digital input signals. (DI)

If an optional digital input board is installed, connect the wiring as shown in Figure 2-1.  
Slot location X = J to P

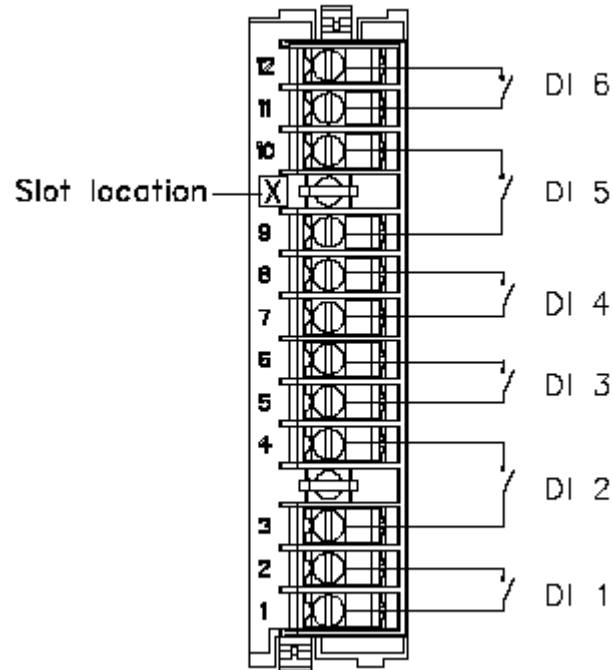

Figure 2-1 Digital input signal wiring (DI)

If 2 digital input boards are fitted, repeat the above procedure for the second board.

Note: Use dry contacts, voltage free, designed to switch 5 mA at 5 V.  
Up to 36 digital inputs allowed.

## 2. INSTALLATION

### 2.5.2 Relay outputs. (DO)

If an optional relay board is installed, connect the wiring as shown in Figure 2-2.  
Slot location X = J to P

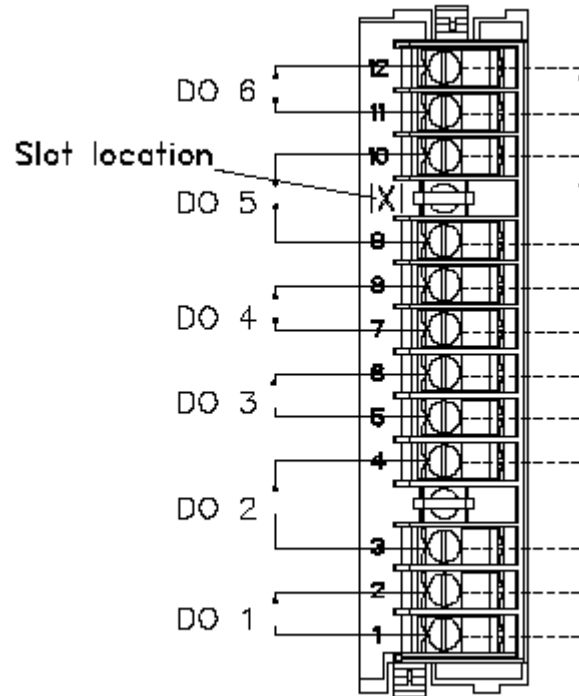

Figure 2-2 Relay output wiring (DO)

All the relays are factory configured **de-energized** in alarm. The contacts are factory configured **normally closed** by a jumper per output on the alarm relay board.

If you need to change this function for normally opened output:

- Turn off power.
- Remove the rear terminal cover plate and remove the relay board, see page 2-11.
- Move the jumper from the location NC (for normally closed) to the location NO (for normally opened).
- Up to 36 alarm outputs allowed.

## 2. INSTALLATION

### 2.5.2.1 Removing the alarm card to change NC to NO contacts

(A) Turn off power.

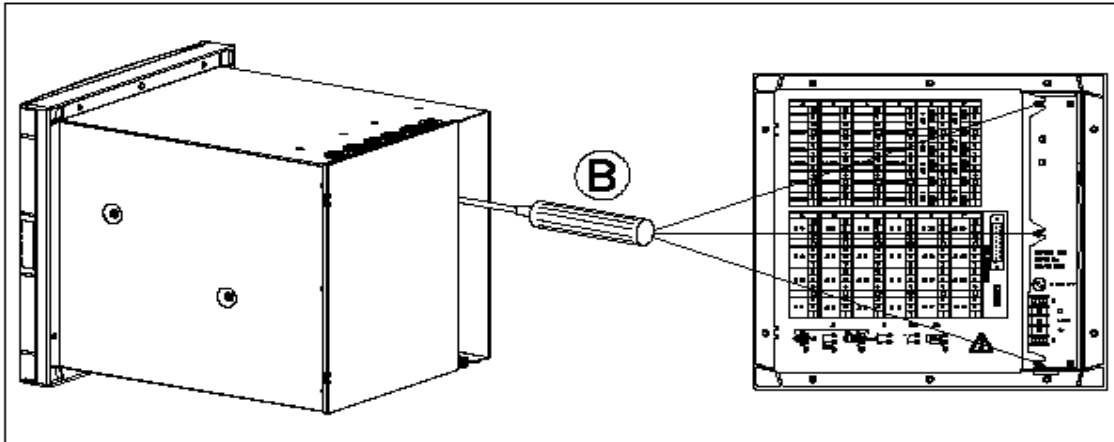

(B) Loosen screws holding rear cover

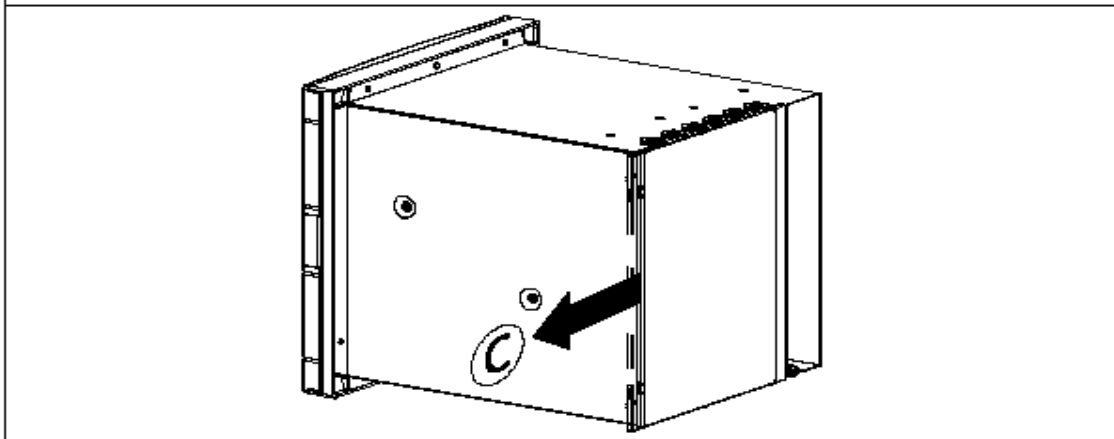

(C) Slide rear cover to the left

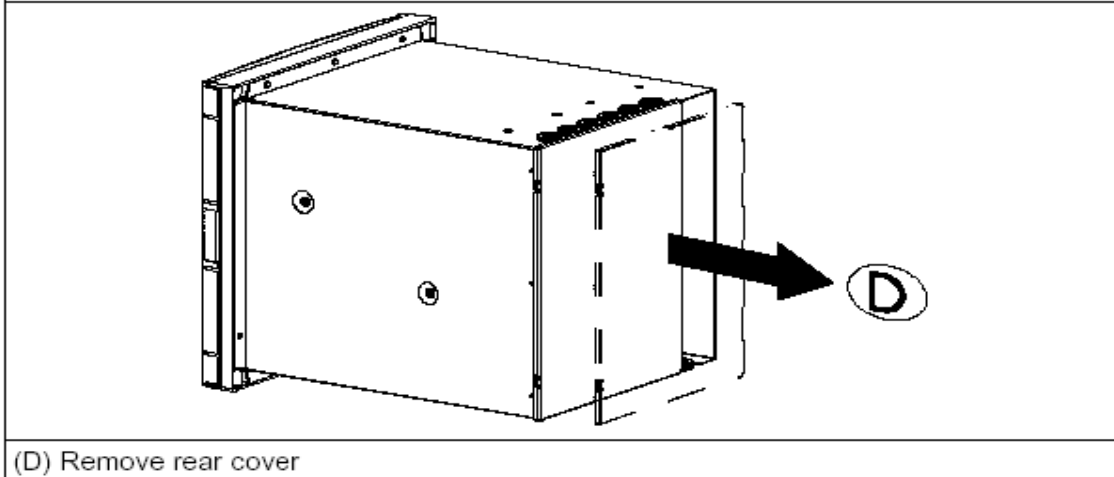

(D) Remove rear cover

## 2. INSTALLATION

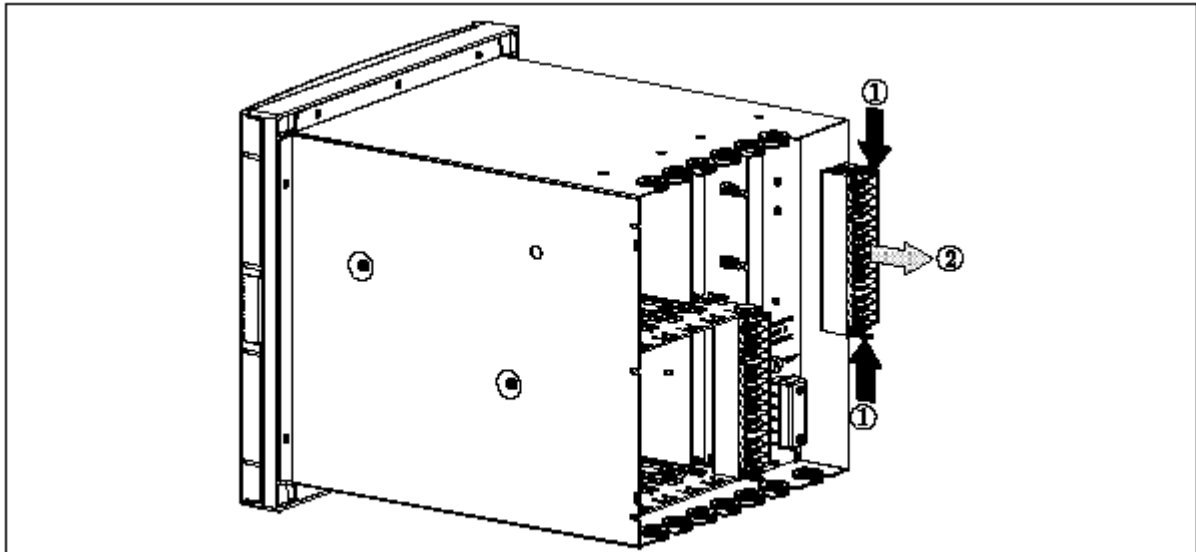

- (1) Press down on terminal block clips
- (2) Pull out to remove from board

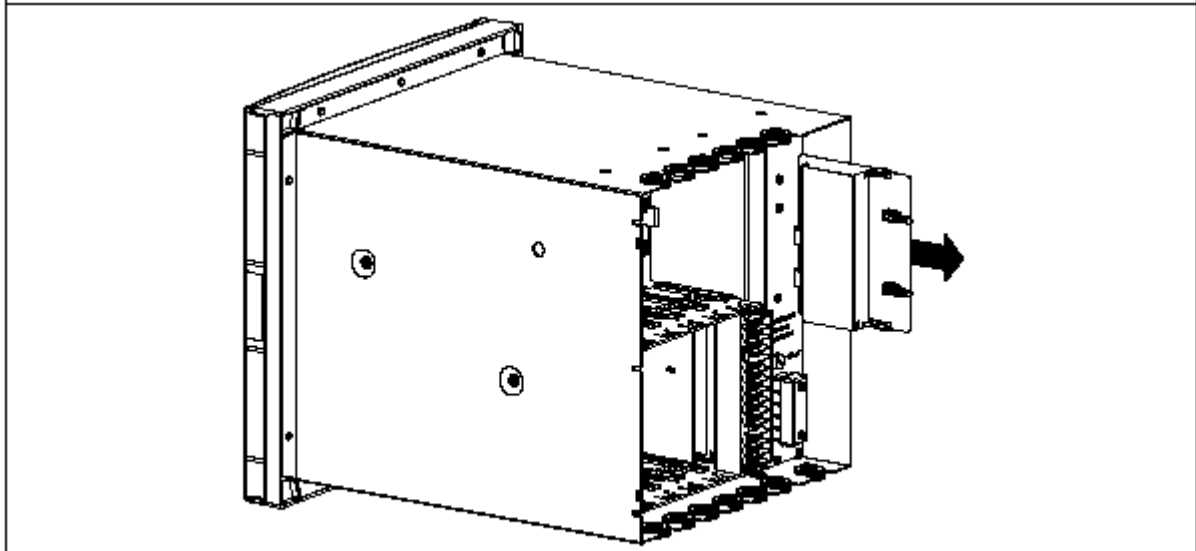

Pull out on board to remove from recorder

Use ground strap to avoid electrostatic damage to board.



### CAUTION

Use ground strap to avoid electrostatic damage to board.

**Failure to comply with these instructions may result in product damage**

## 2. INSTALLATION

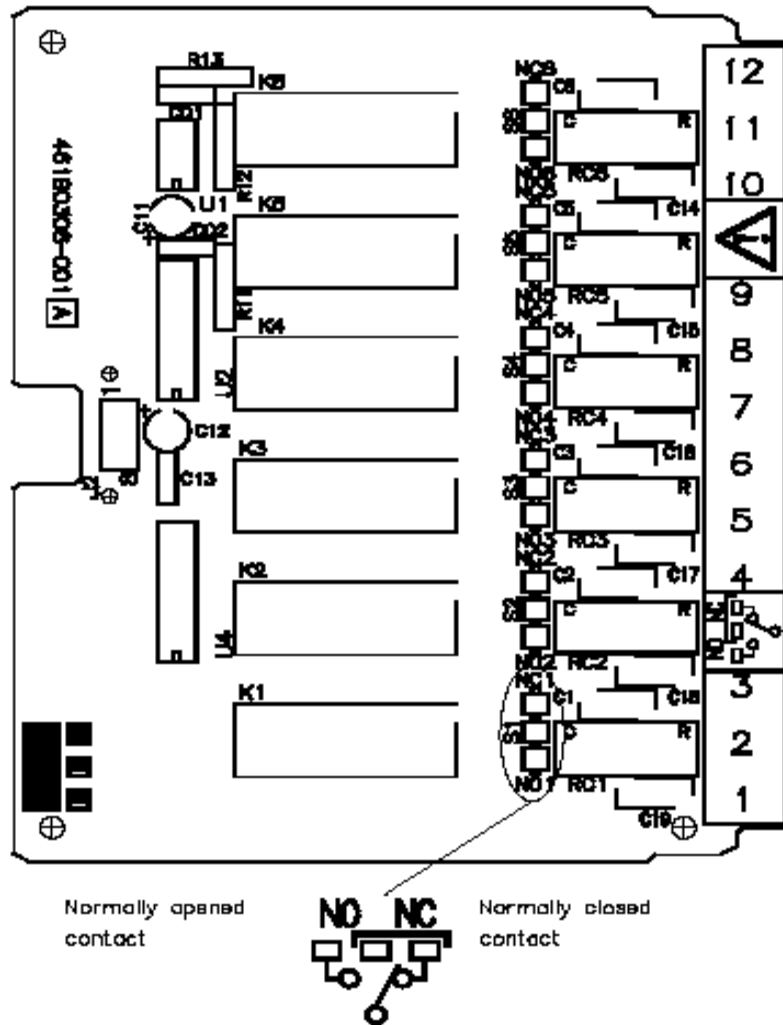

All the relays are factory configured **de-energized** in alarm. The contacts are factory configured **normally closed** by a jumper for each output on the alarm relay board.

If you need to change this function:

- Move the jumper from the location NC (for normally closed) to the location NO (for normally opened)

**2.6 FITTING THE CHART**

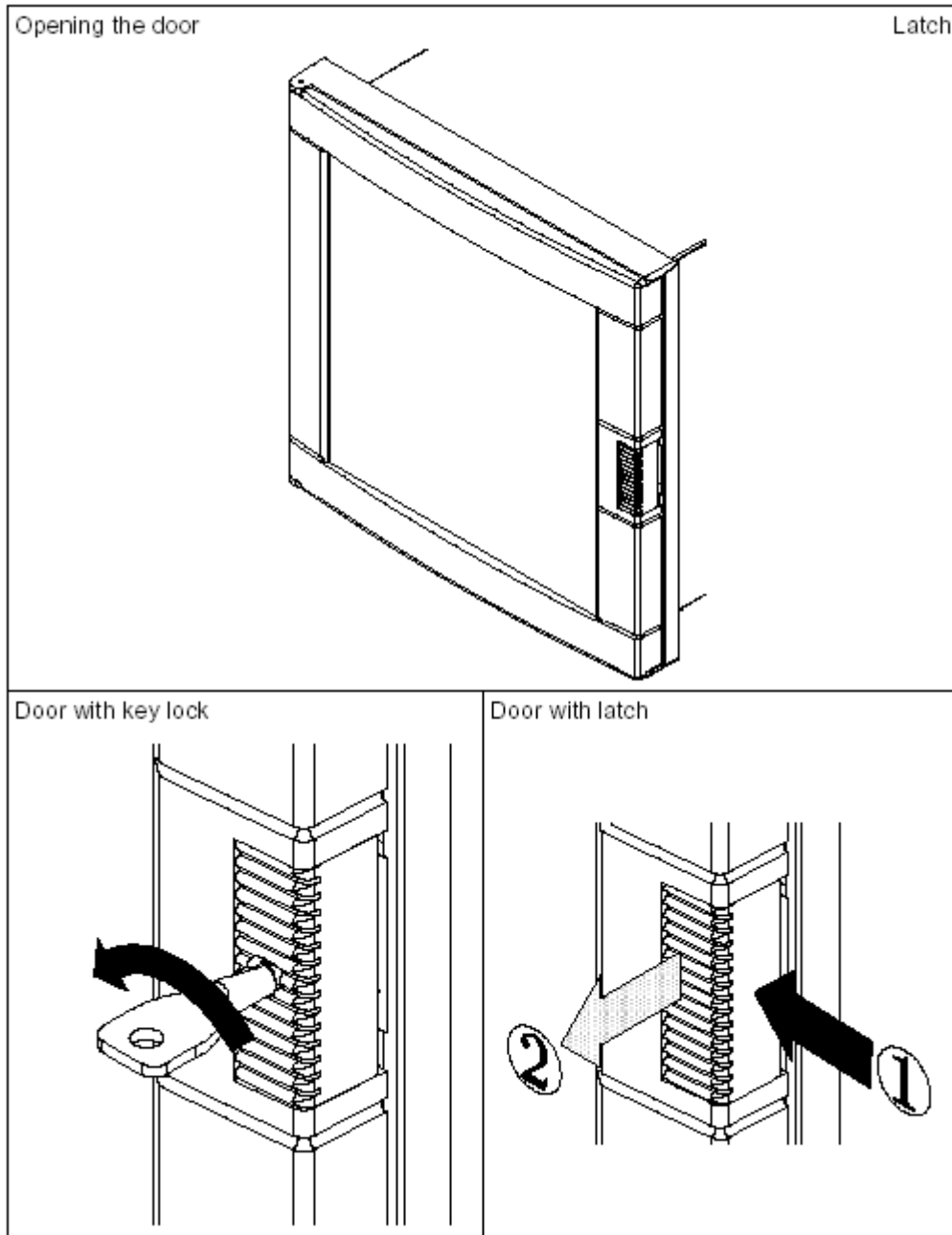

## 2. INSTALLATION

### 2.6.1 Chart cassette

Open the chart cassette as shown below and install the chart using the figure on the cassette.

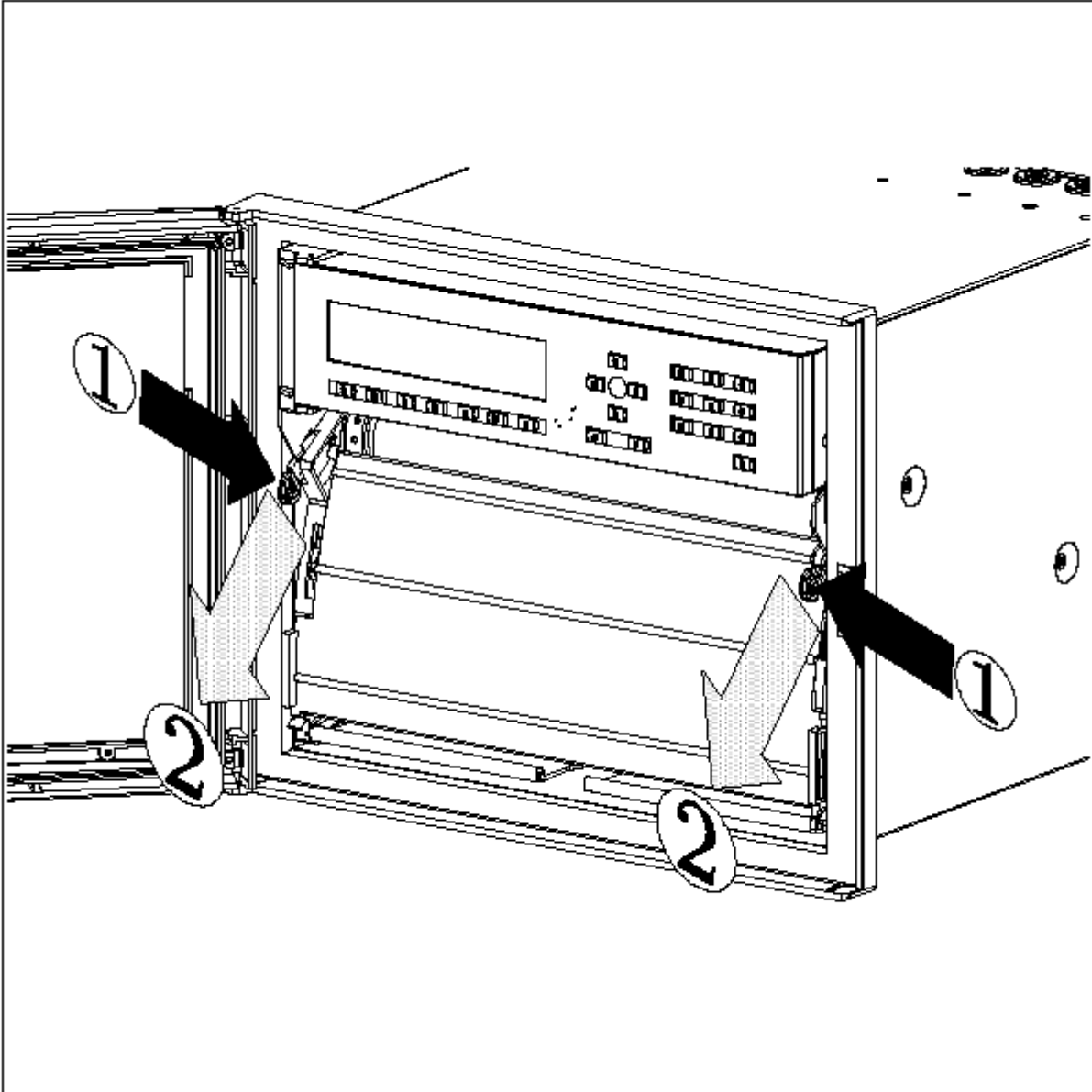

1 = First action - Press in on both tabs to release chart cassette  
2 = Second action - Pull out on the tabs to remove cassette



## 2. INSTALLATION

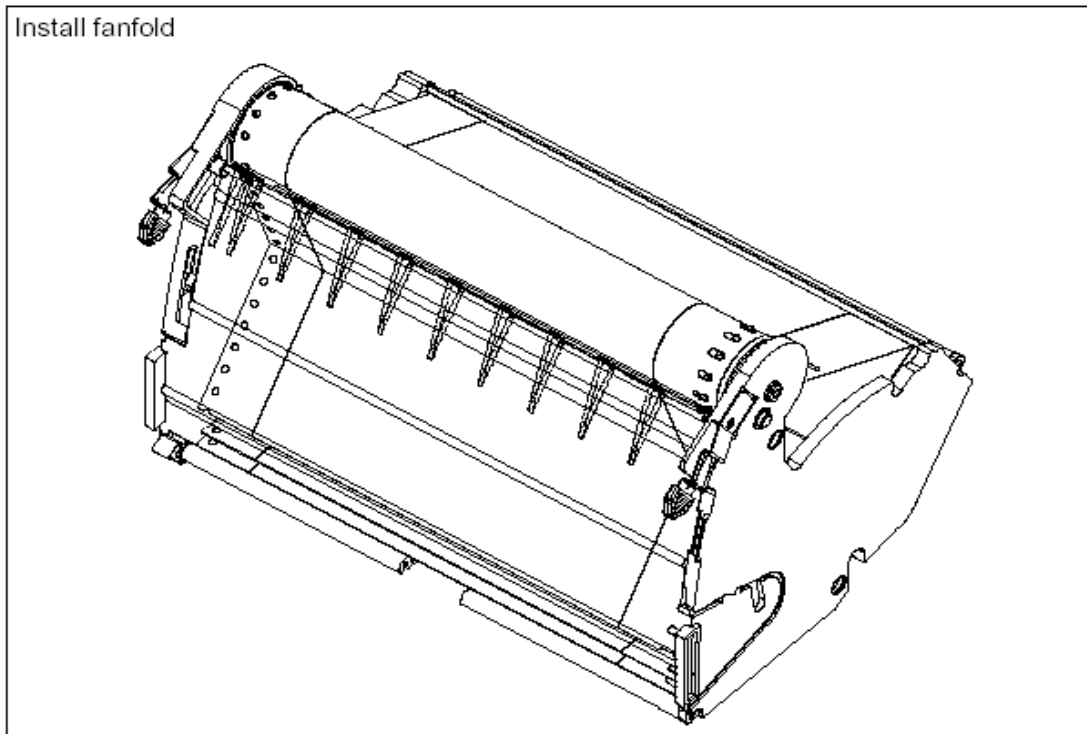
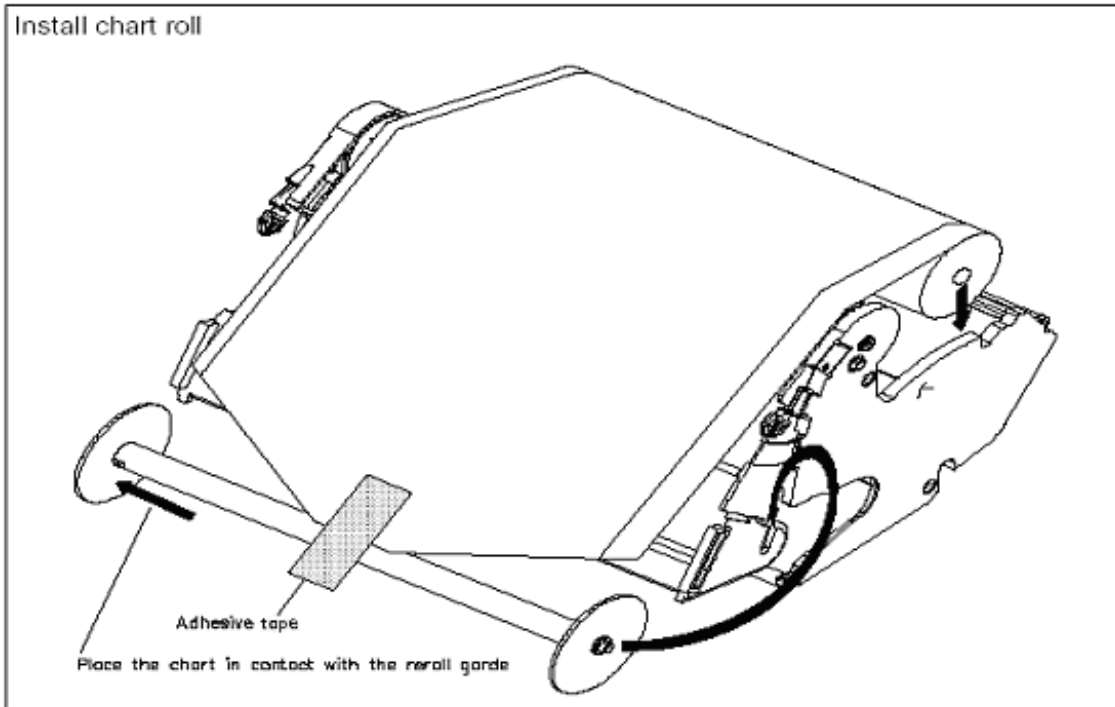

## 2. INSTALLATION

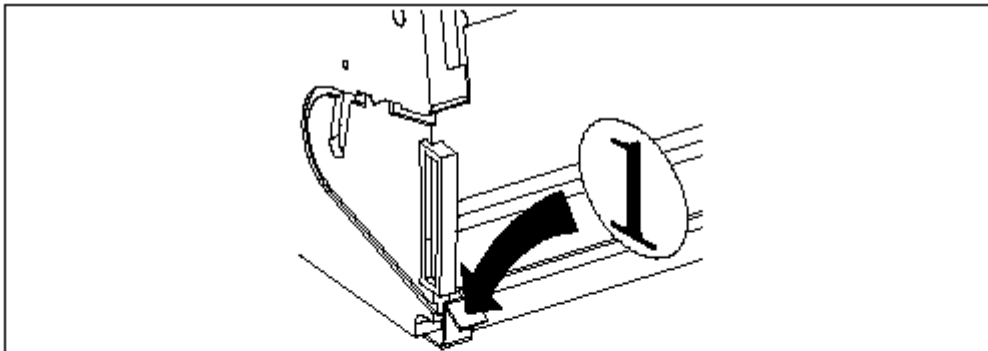

(1) Press down on the catch

Opening the chart cassette

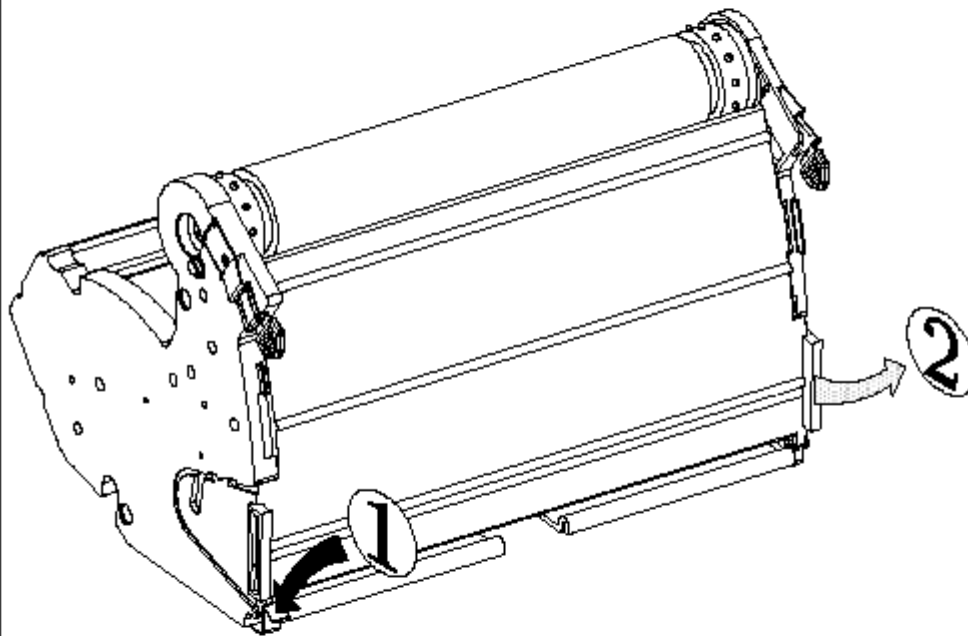

(2) Lift up the clear plastic shield until it latches

Roll chart

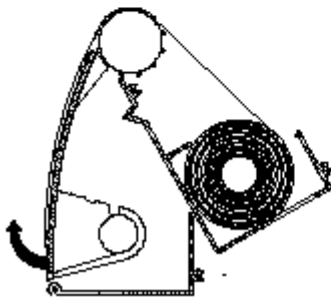

Fanfold chart

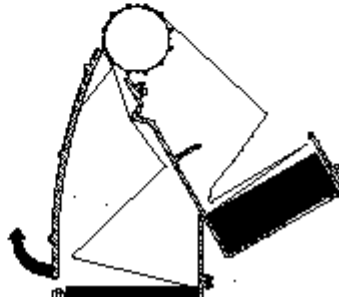

## 2. INSTALLATION

Closing the chart cassette

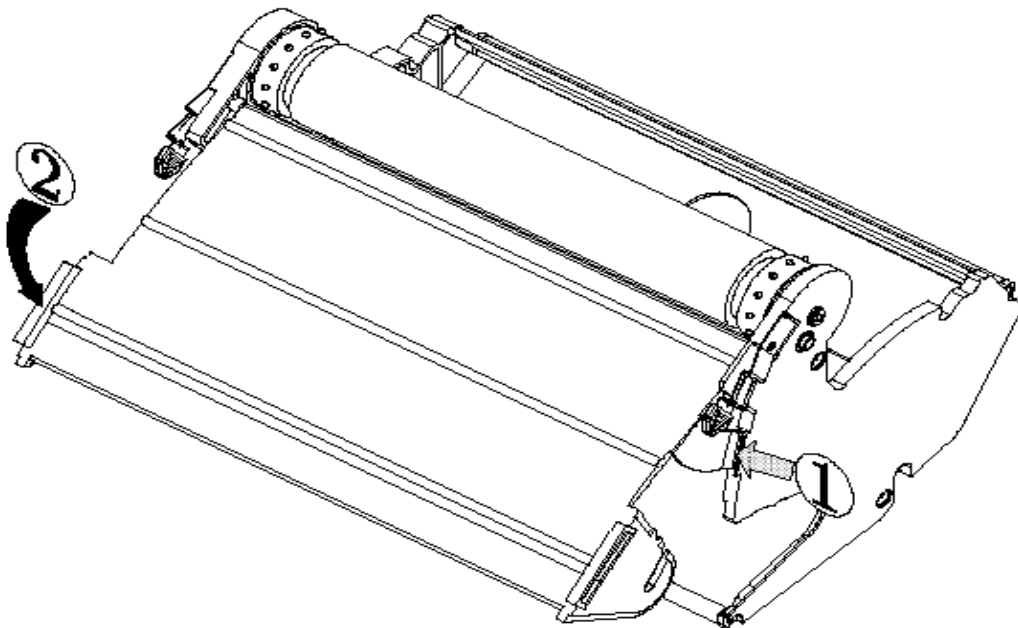

- (1) Press the catch
- (2) Push down to lock in position

Recorder mains Powerswitch - Located behind the chart cassette

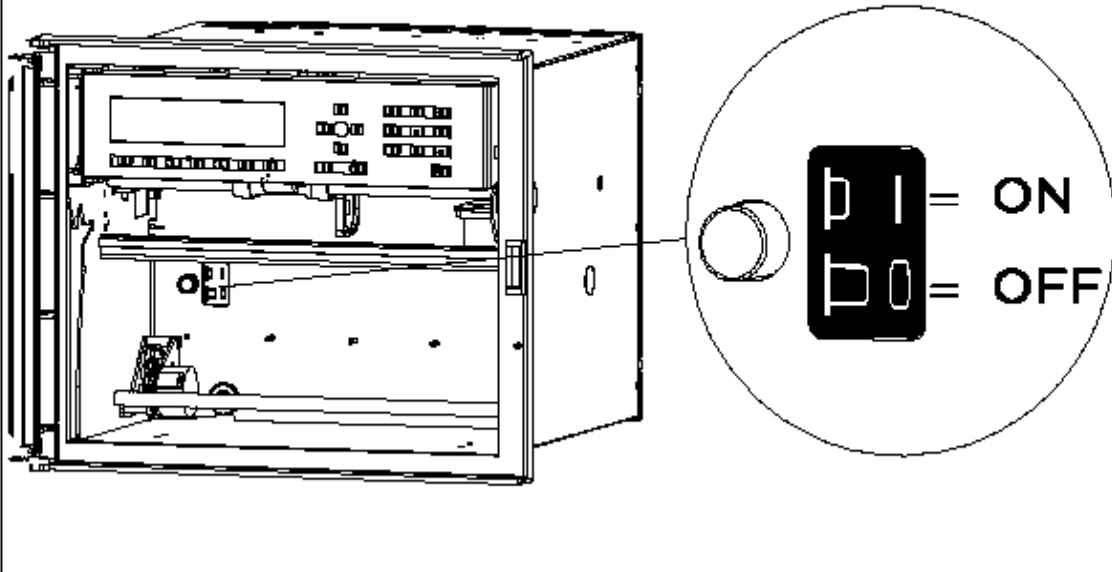

## 2. INSTALLATION

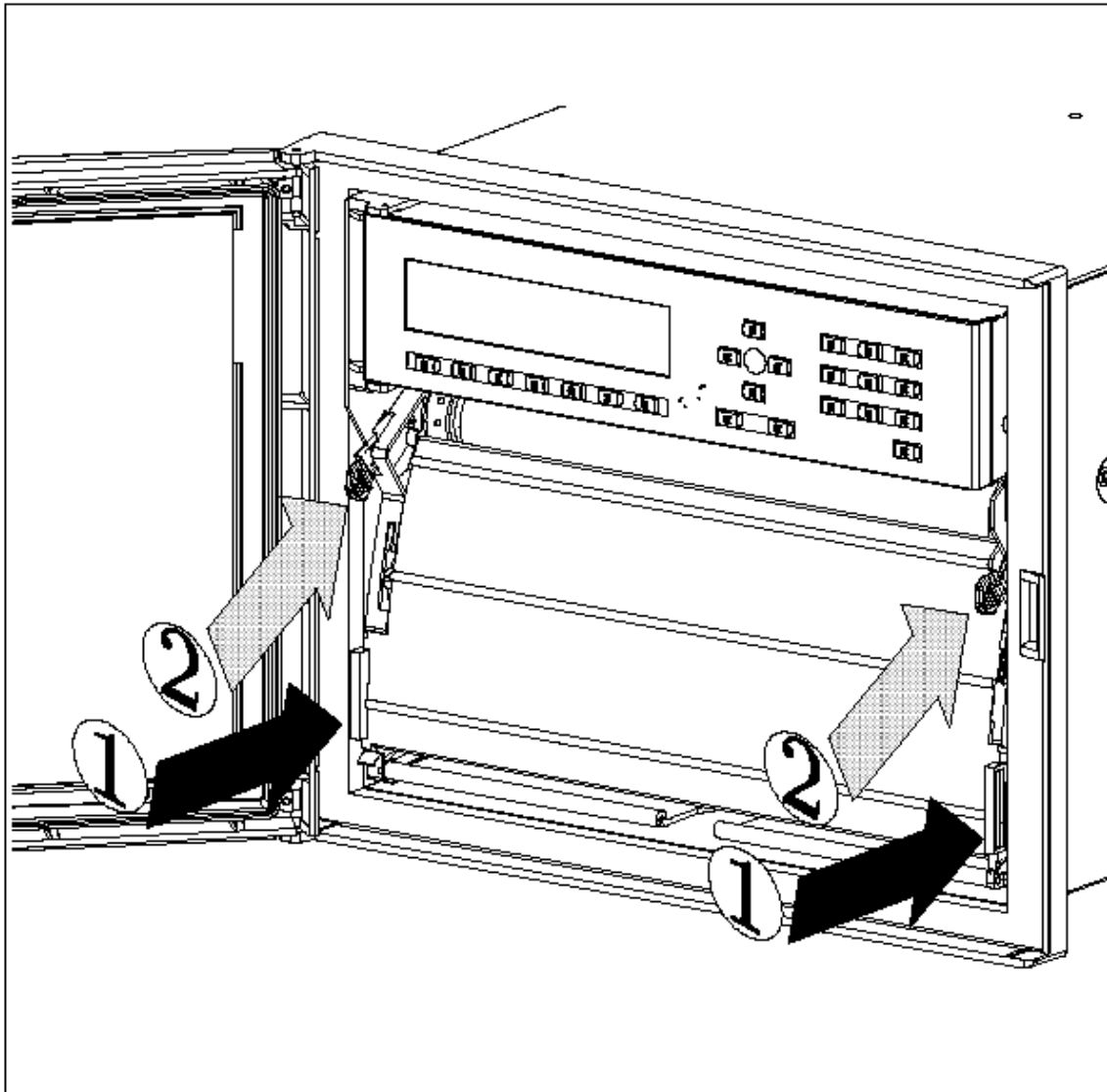

**Note:** If the recorder is powered, and the message "NO PAPER" is indicated on the display, carefully check again that the cassette assembly and chart are correctly installed.

### NOTICE

Reset the paper length (if configured) after installing the new chart. See section 3.2 "OPERATOR INTERFACE".

Length 35 m (115 ft) or less to provide sufficient warning that the paper is near its end.

## 2. INSTALLATION

### 2.6.2 Cleaning the rod and lubricating the carriage bushings

The print carriage bushings are factory lubricated and should not normally require further maintenance.

However, in a dusty environment, you should have to clean the print carriage rod periodically. Also, whenever the print carriage rod is found sticky or dirty, you have to clean it.

The procedure for cleaning and lubricating is explained below:

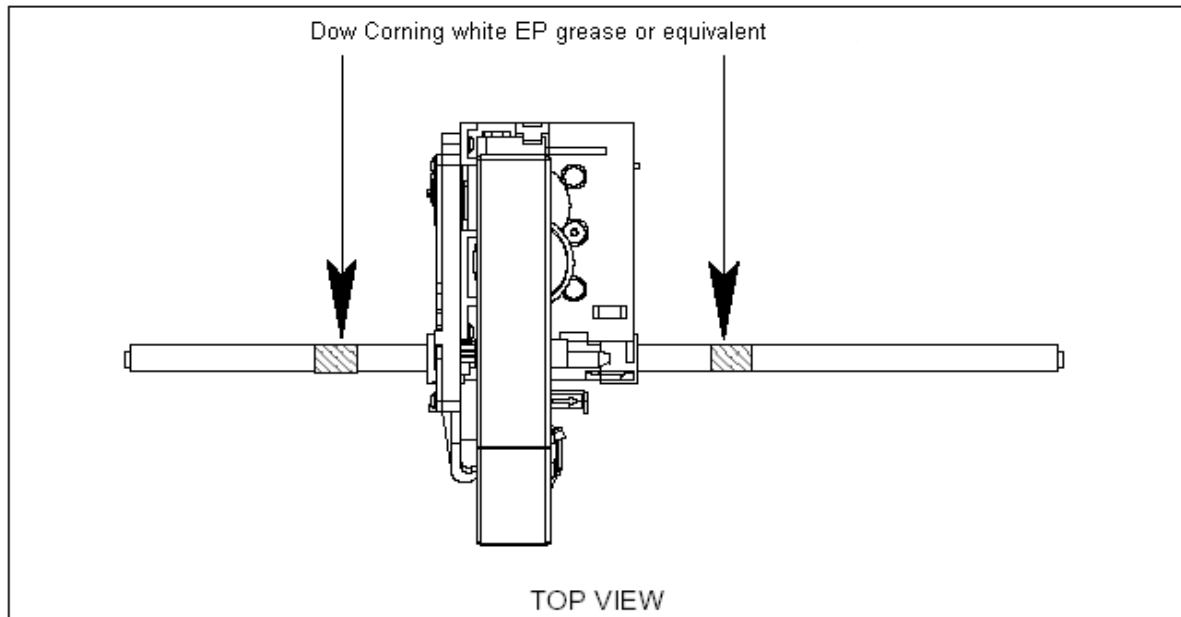

1. Power off the recorder.
2. Clean the rod with a dry, lint free cotton cloth.
3. Move the carriage to the center of the rod.
4. Apply a thin ring of grease around the rod, at each side of the carriage (as shown above).
5. Move the carriage from right to left four or five times.
6. Wipe off any excess grease from the rod with a dry, lint free cotton cloth.



### CAUTION

Never use any solvent to clean the rod.

Please, use only lubricant "Dow Corning white EP grease or equivalent" which may be ordered as part number: "Lubricant kit 46210096-501".

**Failure to comply with these instructions may result in product damage**

### NOTE:

The color ribbon axis (50 mm long), which keeps maintained the color ribbon, must be cleaned with a dry cotton cloth each time you replace the color ribbon.

## 2. INSTALLATION

### 2.7 INSTALLING THE PRINTING SYSTEM

Before doing it, please remove the chart cassette from the chassis as indicated page 2-15.

The recorder automatically moves the print carriage to the correct position for the installation of the ink ribbon cartridge by:

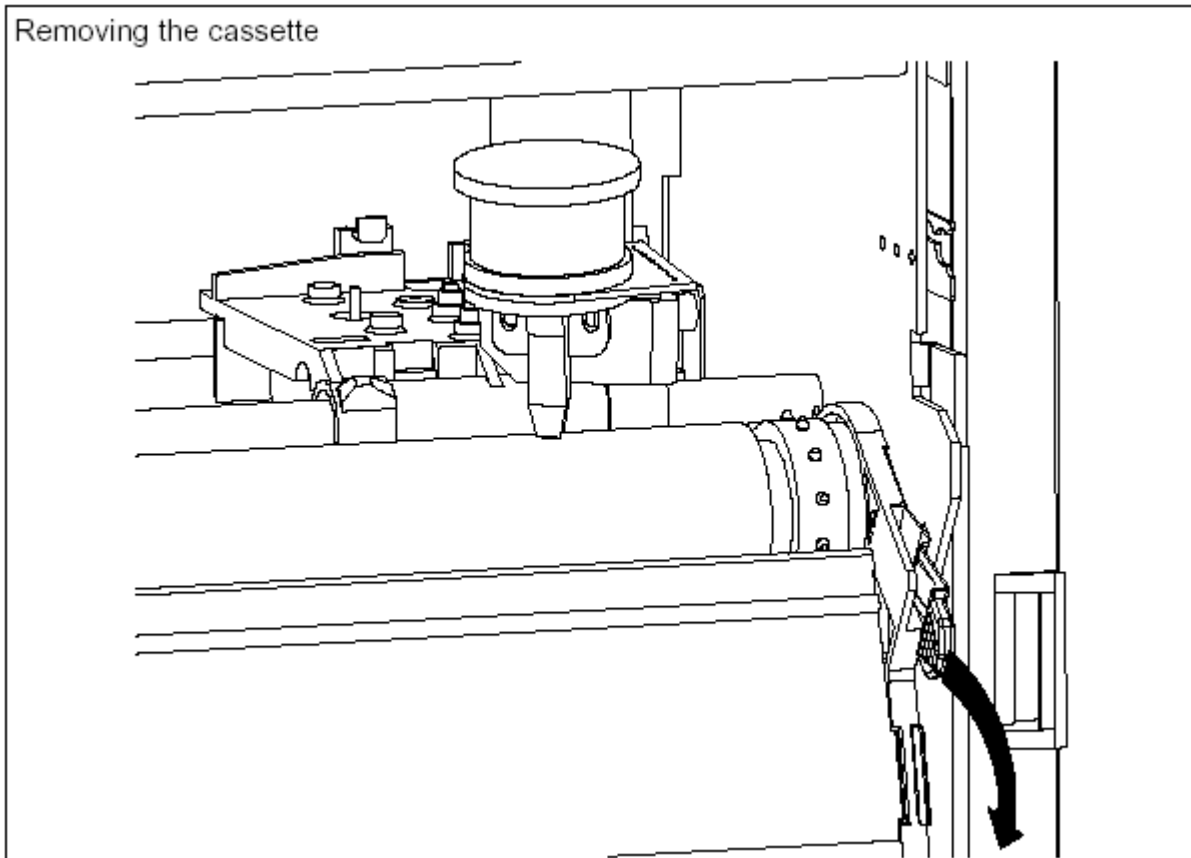

### CAUTION

Do not attempt to install the ribbon cartridge while the chart cassette is in place.

**Failure to comply with these instructions may result in product damage**

## 2. INSTALLATION

Locate the ink ribbon cartridge and align with the guide pin.  
The guide pin should be cleaned at each replacement of the ribbon cartridge.

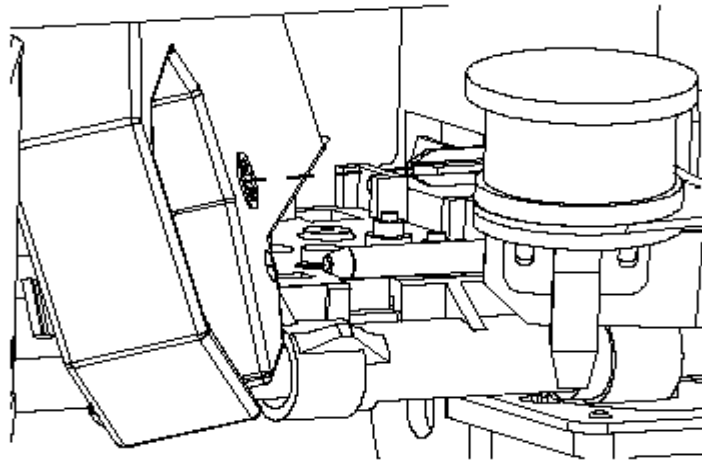

Insert the ink ribbon cartridge

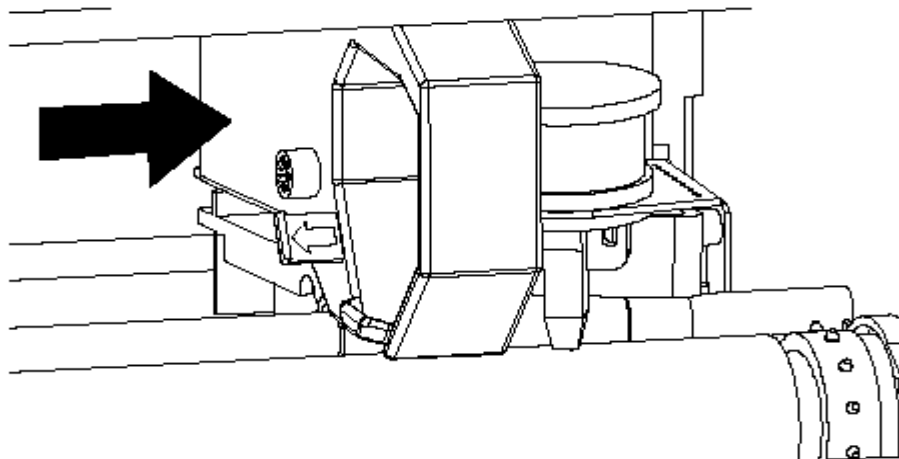

Push the ink ribbon cartridge fully to the right until it stops

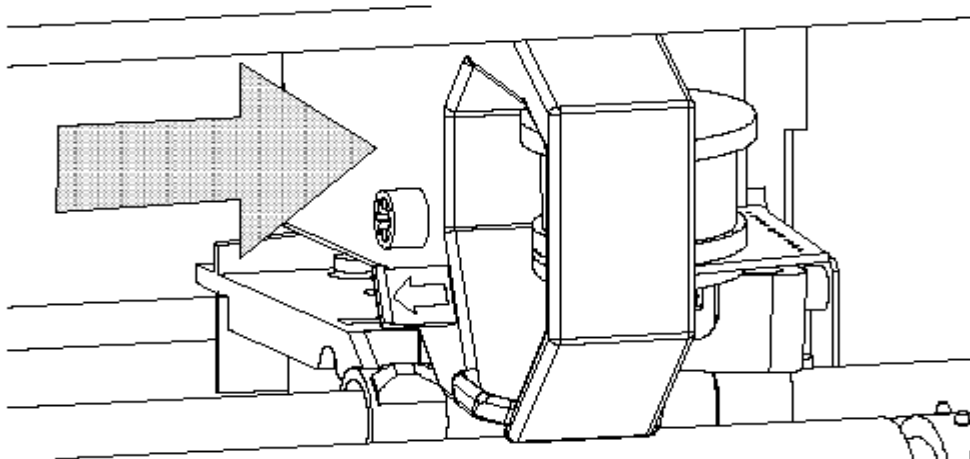

### **2.8 CHECK LIST**

**Your recorder should now be ready to configure and use. If you are having problems check the following**

1. **Have you connected the ground terminal ?**
2. Have you connected the sensor(s) correctly? (Wire type, polarity, etc.)
3. Have you tightened all terminal screws?
4. Have you installed the ink ribbon cartridge? (See figures on page 2-22)
5. Have you installed the chart correctly? (See figures on page 2-15)
6. Have you closed the display?
7. Have you fitted the chart cassette in the recorder?
8. Have you replaced the rear cover?
9. Have you switched ON the power switch?



### TABLE OF CONTENTS

Section	Page
3.1	OPERATOR INTERFACE EXPLANATION . . . . . 3-2
3.2	OPERATOR INTERFACE . . . . . 3-2
3.3	POWER UP . . . . . 3-5
3.3.1	Power up display sequence . . . . . 3-5
3.3.1.1	<i>Display test</i> . . . . . 3-5
3.3.1.2	<i>Measure initialization</i> . . . . . 3-5
3.4	SELECTING AND INTERPRETING RUN MODE DISPLAY. . . . . 3-6
3.4.1	INTRODUCTION . . . . . 3-6
3.4.2	How to select a display type . . . . . 3-6
3.4.3	How to explain displays in run mode. . . . . 3-7
3.4.3.1	<i>For a selection either on the upper display and/or on the lower display</i> . . . . . 3-7
3.4.3.2	<i>Exception: For selections on the 2 displays with the same display type.</i> . . . . . 3-9
3.4.3.3	<i>LOCK displays</i> . . . . . 3-9
3.5	OPERATOR INITIATED ACTIONS . . . . . 3-11
3.5.1	Hold display . . . . . 3-11
3.5.2	Printer action . . . . . 3-12
3.5.3	RESET display . . . . . 3-13
3.5.4	Alarm acknowledgment . . . . . 3-13
3.6	GLOSSARY OF OPERATING DISPLAY MESSAGES . . . . . 3-14

## 3. OPERATION

### 3.1 OPERATOR INTERFACE EXPLANATION

This section describes the various actions which an operator can initiate through the keyboard, and explains how to interpret the displays in the different modes of operation available.

### 3.2 OPERATOR INTERFACE

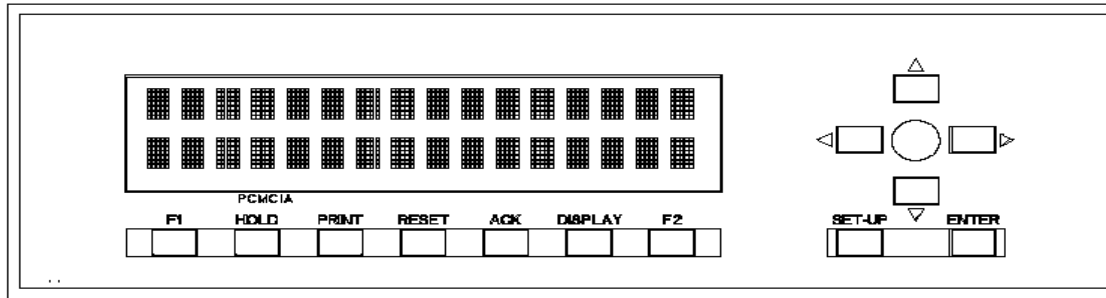

**DISPLAY AND KEYPAD:** The display gives a clear indication of action prompts by means of two lines of 16 characters and the keypad consists of 23 keys.

- 7 function keys that enable you to start immediate action. See table below.

FUNCTION KEYS						
F1	HOLD	PRINT	RESET	ACK	DISPLAY	F2
Immediate action key configurable	To hold the display on a current channel.  Use ▲ and ▼ keys to change the channel.	To choose an Immediate printing action. The choices are: - Inhibit/Printing - Reset paper length - Change speed/ int 2 to speed/ int 1 - Print date & time - Snap shot trace - Chart advance - Change group B to A - Change group A+B to B - Snap shot logic - Snap shot math - Start archive/stop archive - Remove PCMCIA	- Math - Occurrence - Reset PCMCIA	To Acknowledge all latching alarm relays	To choose the display type in run mode or to escape from configuration to run mode	Immediate action key configurable

**NOTE:** The function keys are used in run mode and they control the contents of the display and other functions. In case of a power loss the configuration is unchanged.

- ◀▶▲▼ : THESE KEYS ARE USED FOR PRODUCT CONFIGURATION.
- **SET UP:** To move to configuration mode or to return from parameter configuration to the sub-matrix.
- **ENTER:** To confirm your selected action.
- An ALPHANUMERIC keypad with either capital and small print letters, digits or special characters.

### 3. OPERATION

The keypad is designed to simplify the way to configure your parameters.  
Two kinds of parameters are possible:

1. Parameters in which you only have to enter digits (eg: CHART SPEED) or to enter a letter (COPY function). Both cases, the keyboard will automatically be configured correctly.
2. Parameters which need every possible ASCII characters defined in the recorder (eg: MESSAGE). When you confirm the action to enter configuration mode, a triangle in the right hand bottom corner of your display is lit. It indicates that you are in capital letter mode. Depending on the type of characters you wish to enter, you will have to press the F2 key. Then it will automatically shift to the next group of characters (digits, small print letters, special characters, capital letters) indicated on the display by a triangle. Then you will be able to select the way you wish to write the text.

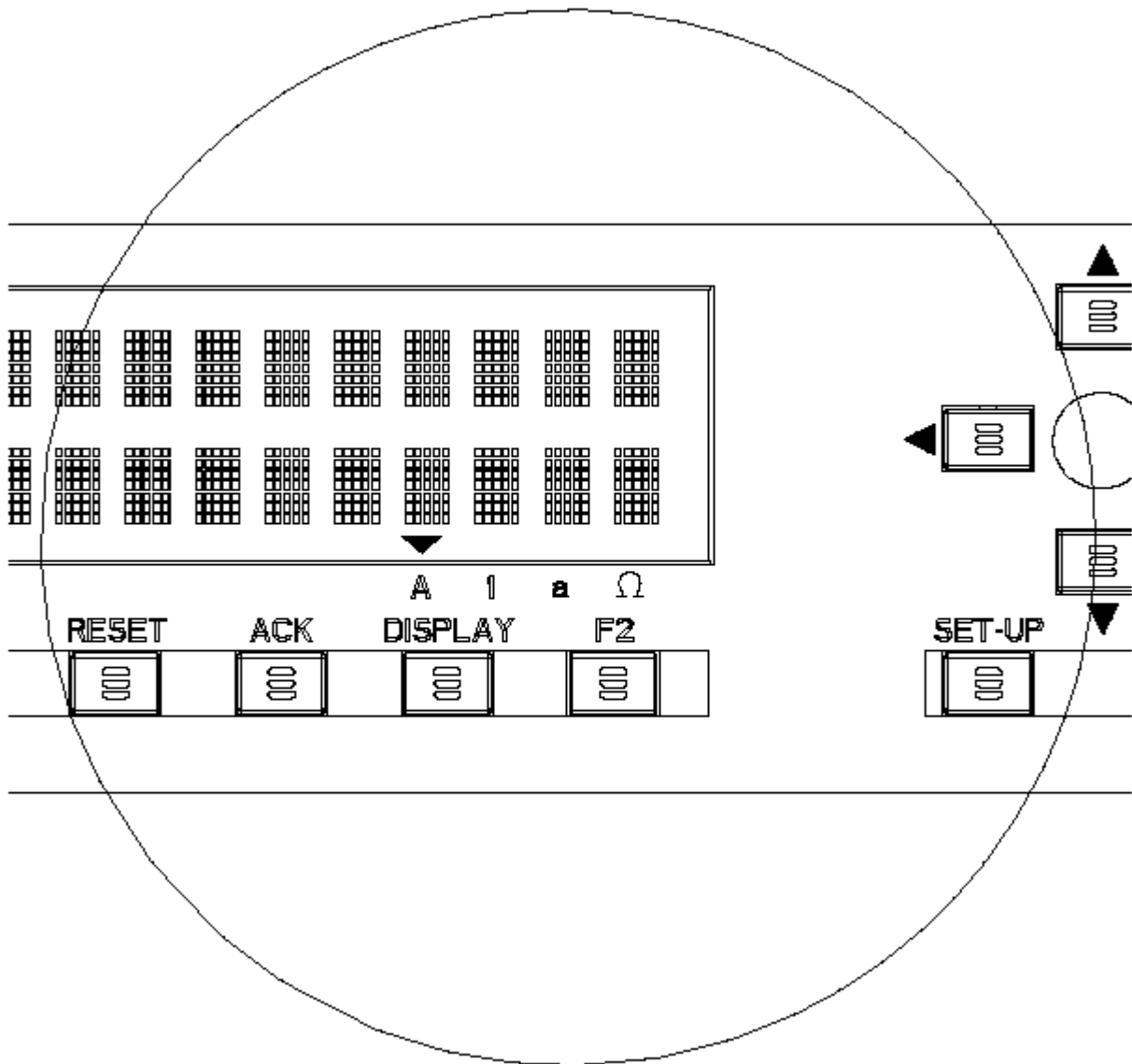

### 3. OPERATION

You will find in the table below the different letters associated to each key:

Digits	Capital letters	Small print letters	Special characters					
1 ABC		abc	Ω	°	A Ampere	V Volt	C Celsius	F Fahrenheit
2	DEF def		Ä	Ö	Ü	ñ	Ñ	Å
3	GHI ghi		/	*	- +		±	.
4	JKL jkl		[ ]		( )		{ }	
5	MNO mno		.	,	;	:	!	?
6	PQR pqr		=	≠	< >		≤	≥
7	STU stu		"	_	#	\$	% &	
8 VWX		vwx	m milli	K kilo	μ micro	M mega	n nano	G giga
9	YZ y	z	\	√	Σ	φ	∫	^
0, -	Space	Space	Space					

**Note:** The selection can also be made with the ▲ and ▼ keys in the same way as for parameters containing a list of choices.

### 3.3 POWER UP

#### WARNING



Before powering up, check your recorder is correctly installed. See section 2, "INSTALLATION".

**Failure to comply with these instructions could result in death or serious injury**

#### 3.3.1 Power up display sequence

After powering up, check the messages appear on the displays in the following order:

##### 3.3.1.1 Display test

Check that all dots for each character, commas and triangle marks are lit.

Upper display shows:

**INITIALIZATION**

If the communication board is present,

Upper display shows:

**INITIALIZATION**

Lower display shows:

**COMMUNICATION**

##### 3.3.1.2 Measure initialization

Upper display shows:

**INITIALIZATION**

Lower display shows:

**MEASURE**

During a few seconds, the recorder reads and analyzes every inputs. After these operations of initialization, input values appear on the 2 displays in run mode.

### 3.4 SELECTING AND INTERPRETING RUN MODE DISPLAY

#### 3.4.1 INTRODUCTION

The recorder allows you to choose between a lot of display types when in the normal scanning mode. At the end of the power display sequence (see section 3-5, "POWER UP"), the display will be in the scanning mode, in the display type you have selected in the configuration matrix of the display (Parameters: DISPLAY HI, DISPLAY LO).

To select another display type (for the lower and/or the upper display), use the **DISPLAY** key (See next section 3.4.2 ) or use the configuration mode.

#### 3.4.2 How to select a display type

- The immediate action keys are not available if you are in configuration mode.
- The selection of the **DISPLAY** key is lost at the power off.
- Press the **DISPLAY** key. Then you can read:

**DISPLAY HI**

The upper display is flashing.

**DISPLAY LO**

- The ▲ and ▼ keys allow you to select the desired display. Confirm your choice by pressing the **ENTER** key.

According to your choice, you may obtain:

**DISPLAY HI**

**ANALOG INPUTS**

Electrical input signal

or

**DISPLAY LO**

**ANALOG INPUTS**

Electrical input signal

- The ▲ and ▼ keys allow you to select the desired display mode on the lower display.

### NOTICE

In particular cases, you may be allowed to select a display type or a parameter only in the upper display. See section 3.4.3.3, "LOCK displays".

#### 3.4.3 How to explain displays in run mode

##### 3.4.3.1 For a selection either on the upper display and/or on the lower display

- **ANALOG INPUTS**

Analog input numbers, measured values and sensor engineering units will be displayed.

**AN 0 1 1 2 4 . 2 ° C**

AN = mnemonic for analog input

- **Two printed channels on the same display**

**0 1 2 4 . 2 & 2 4 . 3**

01: channel number

24.2: channel value of channel 1

24.3: channel value of channel 2

Note that the second channel number is incremented by 1 from the first channel number. If, for example, the first channel is not configured, no value will be displayed, e.g.

**0 3            & 2 4 7 . 2**

- **COMMUNICATION CHANNELS**

**COM 0 1 2 5 4 . 9**

- **COM** = mnemonic for communication channel

### 3. OPERATION

- **ALARMS**

For each operated alarm, alarm number, alarm state, relay number, relay state, channel type and channel number will be displayed.

**AL 0 4 ■ - RL 0 6 \_ - AN 1 1**

**AL 0 4 ■ - RL 0 6 \_ - MA 1 2**

**AL 0 4 ■ - RL 0 6 \_ - CO 0 1**

■ active      \_ inactive      . = missing

AL = mnemonic for alarm

RL = mnemonic for relay

AN = mnemonic for analog input

MA = mnemonic for maths results

CO = mnemonic for comm. Channels

- **SPEED IN USE**

In the trend mode, speed number, value and unit will be displayed.

**SP 1      1 5 0mm / h**

SP 1 or SP 2 = mnemonic for speed 1 or speed 2

In tabular mode, interval name, time and unit will be displayed.

**INT 1      1 0 m i n**

INT1 or INT2 = mnemonic for interval 1 or interval 2

- **DATE AND TIME**

Day, month, year, hour "h" and minutes will be displayed.

**2 5 FEB 9 6   1 1 h 1 3**



### 3.4.3.2 Exception: For selections on the 2 displays with the same display type

In this case the upper display shows odd numbers and the lower one shows even numbers.  
For example:

**AN 0 1    1 2 4 . 2    °C**

**AN 0 2    5 4 4 . 7    °C**

If a channel is not configured or does not exist, when previous or next channel is correct, then display mode and channel number are only displayed. See the examples below:

Only channel 01 is not correct:

**AN 0 1**

**AN 02    1 4 . 1    °C**

Only channel 06 is not correct:

**AN 0 5    7 4 . 3    °C**

**AN 0 6**

### 3.4.3.3 LOCK displays

In this case you are allowed to select a display mode only in the upper display.

- **MATHS RESULTS**

**MA 2 0    TAG    NAME**

**1 . 3 2 E + 1 2    UNITS**

The upper display shows the tag name  
The lower display shows the value and unit of maths results.  
To display maths results, the maths option is required

### 3. OPERATION

- **TAG NAME AND TRACE**

LOCK displays mean that the 2 displays are necessary to keep information together.

**TAG NAME**

**01 258.1 UNITS \_**

The upper display shows the channel name.

The lower display shows number, value, unit and indicator of the alarm.

If the channel is in alarm status and if the alarm parameter (See EVENTS matrix, ONE ALARM ON parameter) is not valid, then the "A" indicator appears on the last digit of the display. On the contrary units are displayed and the alarm number is displayed just after, as follows

If ALARM and EVENTS are ON:

**TAG NAME AL 1 2**

**01 258.1 UNITS ■**

- **TRACES IN ALARM**

The upper display shows the name of the display type "TRACE IN ALxx-yy" and the display interval of the lower display.

**TRACE IN AL xx - yy**

**#####**

The lower display shows the trace status of alarm.

"xx" - "yy" takes values from "01 to 16" or "17 to 24".

# = you may have:

■ active      \_ inactive      . = missing



### 3.5.2 Printer action

The **PRINT** key allows you to choose between various actions.  
Press **PRINT** key and the upper display shows during a few seconds:

**BASIC ACTION**

and just after:

**PRINT MENU**

**INHIBIT**

or

**PRINTING**

**RESET PAPER LENG**

**SPEED / INT 2**

or

**SPEED / INT 1**

**PRINT DATE & TIME**

**SNAP SHOT TRACE**

**CHART ADVANCE**

The chart advances as long as the  
**ENTER** key is pressed.

**CHG GROUP B**

or

**CHG GROUP A**

**CHG GROUP A + B**

or

**CHG GROUP B**

**SNAP SHOT LOGIC**

**SNAP SHOT MATH**

**START ARCHIVE**

or

**STOP ARCHIVE**

**REMOVE PCMCIA**

Only when PCMCIA option is installed.

Press **ENTER** and use ▲ or ▼ to choose the display type.

#### 3.5.3 RESET display

**RESET MATH #**

Only when MATH OPTION is configured.

**RESET ALL MATHS**

**RESET OCCURRENCE**

**RESET ALL OCCUR**

**RESET PCMCIA**

Only when PCMCIA option is installed.

#### 3.5.4 Alarm acknowledgment

Pressing **ACK** key is only allowed for alarms you have configured in acknowledgment mode.  
This acknowledgment is only available

- if the lower display shows alternately:

**REQUEST ACK NOW**

and the display type,

- if the **ACK** key is active.

(See **ACK KEY** parameter in the MMI sub-matrix)

### 3.6 GLOSSARY OF OPERATING DISPLAY MESSAGES

- ENTERING IN THE IMMEDIATE ACTION MODE

#### **BASIC ACTION**

- DISPLAY CHOICE

#### **DISPLAY HI**

#### **DISPLAY LO**

- DISPLAY MODE CHOICE

#### **ANALOG INPUTS**

Electrical input signal

#### **2 PVS TRACE**

Process value in engineering unit

#### **MATH RESULTS**

Only when MATH OPTION is configured.

#### **COMM RESULTS**

Only when COMM OPTION is configured.

#### **ALARM STATUS**

#### **SPEED IN USE**

**DATE & TIME**

**TRACE & TAG**

**TRACE IN ALARM**

**LOGIC STATES**

- **ACK MESSAGES**

**REQUEST ACKNOW**

**ACKNOWLEDGMENT**

- **INFORMATION MESSAGES**

**NO PAPER**

**END PAPER**

**BATTERY FAIL**

**ONE ALARM ON**

**BURNOUT**

**PRT INHIBIT**

**OVER FLOW SPEED**

**SHED TIME**

Only when COMM option is configured.

**PCMCIA FULL**

**PCMCIA BAD**

**PCMCIA NOT INIT**

**PCMCIA PENDING**

**REMOVE PCMCIA**

Only when PCMCIA option is configured.

- Diagnostic Messages

**BAD CARRIAGE DISP**

**BAD REFERENCE**

**BAD EEPROM BACKPLANE**



### TABLE OF CONTENTS

Section	Page
4.1	INTRODUCTION . . . . . 4-2
4.2	PARAMETERS LIST . . . . . 4-4
4.3	PRINCIPLE OF CONFIGURATION . . . . . 4-5
4.4	COPY CONFIGURATION . . . . . 4-105
4.4.1	Introduction . . . . . 4-105
4.4.2	Configuration . . . . . 4-105
4.4.3	WARNING . . . . . 4-109
4.5	PRINT CONFIGURATION . . . . . 4-110
4.5.1	Introduction . . . . . 4-110
4.5.2	Configuration . . . . . 4-111
4.5.3	Information about printing . . . . . 4-115
4.5.4	WARNING . . . . . 4-115
4.6	CONFIGURABLE AND PRINTABLE CHARACTERS . . . . . 4-116
	INDEX . . . . . 4-117

## 4. CONFIGURATION

---

### 4.1 INTRODUCTION

The recorder can be configured - using the front keyboard or by using the PC configurator and L.P.C.S. When using the keyboard there are two possible levels of password that can be configured. Password 1 provides limited configuration access as shown on the configuration sheet (See page 4-92). Password 2 provides full configuration of all parameters (See page 4-93).

Page 4-1 provides a key to each explanation for the individual parameters.

To begin configuration you only need to press **SET UP**. The recorder will indicate "CONFIGURATION", "ACCESS" and wait for a password to be entered if one has been programmed. If no password has been programmed the recorder will display the "READ/WRITE", "ANALOG INPUT" position (see programming matrix). You can now use the LEFT or RIGHT side arrows to select the sub-matrix you want to configure (i.e. ANALOG INPUT, CHART, ALARM etc.) or the UP or DOWN arrows to select the READ/WRITE, COPY, PRINT CONF or SERVICE matrices and then use the LEFT or RIGHT arrow to enter into one of these sub-matrices. When you have selected the sub-matrix that you want to configure you only need to press **ENTER** to begin configuration of this sub-matrix.

Each sub-matrix such as ANALOG INPUT has a number of parameters associated with it that need to be configured in order to set up that parameter and channel. Each parameter needs to be configured for each input. To exit from the configuration mode press **DISPLAY** or **SET UP** keys.

## 4. CONFIGURATION

---

<i>SUB-MATRIX</i>	<i>PARAMETER</i>	<i>CLASSIFICATION</i>
<b>NAME OF THE FUNCTION</b>	<b>NAME OF THE PARAMETER</b>	<b>IMPORTANCE OF THE PARAMETER</b> ◆ CAN BE CHANGED IN RUN MODE ◆◆ STOP OF ACQUISITIONS □ WITH PASSWORD 1 OR 2 □□ ONLY WITH PASSWORD 2

---

**DEFINITION:** EXPLAIN THE ROLE OF THE PARAMETER

**HOW TO MODIFY IT:** BY SELECTING OR ENTERING A NEW VALUE I.E. USING THE ▼ ▲ KEYS

**POSSIBLE VALUES:** LIST OF POSSIBLE VALUES OR LIMITS

**SEE ALSO:**

**EXAMPLE:**













**NOTE:**

---

**NOTICE** The configuration of parameters with the classification “◆◆” stops the acquisition as well as the operation of alarm supervision. Leaving the configuration mode resets the memory buffer and the alarm status is defined again, and the chart speed changes back to the configured value. Occurrence value is reset.

---

### 4.2 PARAMETERS LIST

	<b>ANALOG INPUT</b>	page 4-6
	<b>CHART</b>	page 4-20
	<b>ALARM</b>	page 4-31
	<b>DIGITAL</b>	page 4-47
	<b>MESSAGES</b>	page 4-57
	<b>PRINTER</b>	page 4-60
	<b>CHART DOC</b>	page 4-69
	<b>MMI</b>	page 4-77
	<b>EVENTS</b>	page 4-84
	<b>MISCELLANEOUS</b>	page 4-88
	<b>PERIODIC REPORT</b>	page 4-96
	<b>CURRENT 4/20 mA</b>	page 4-102

## 4.3 PRINCIPLE OF CONFIGURATION

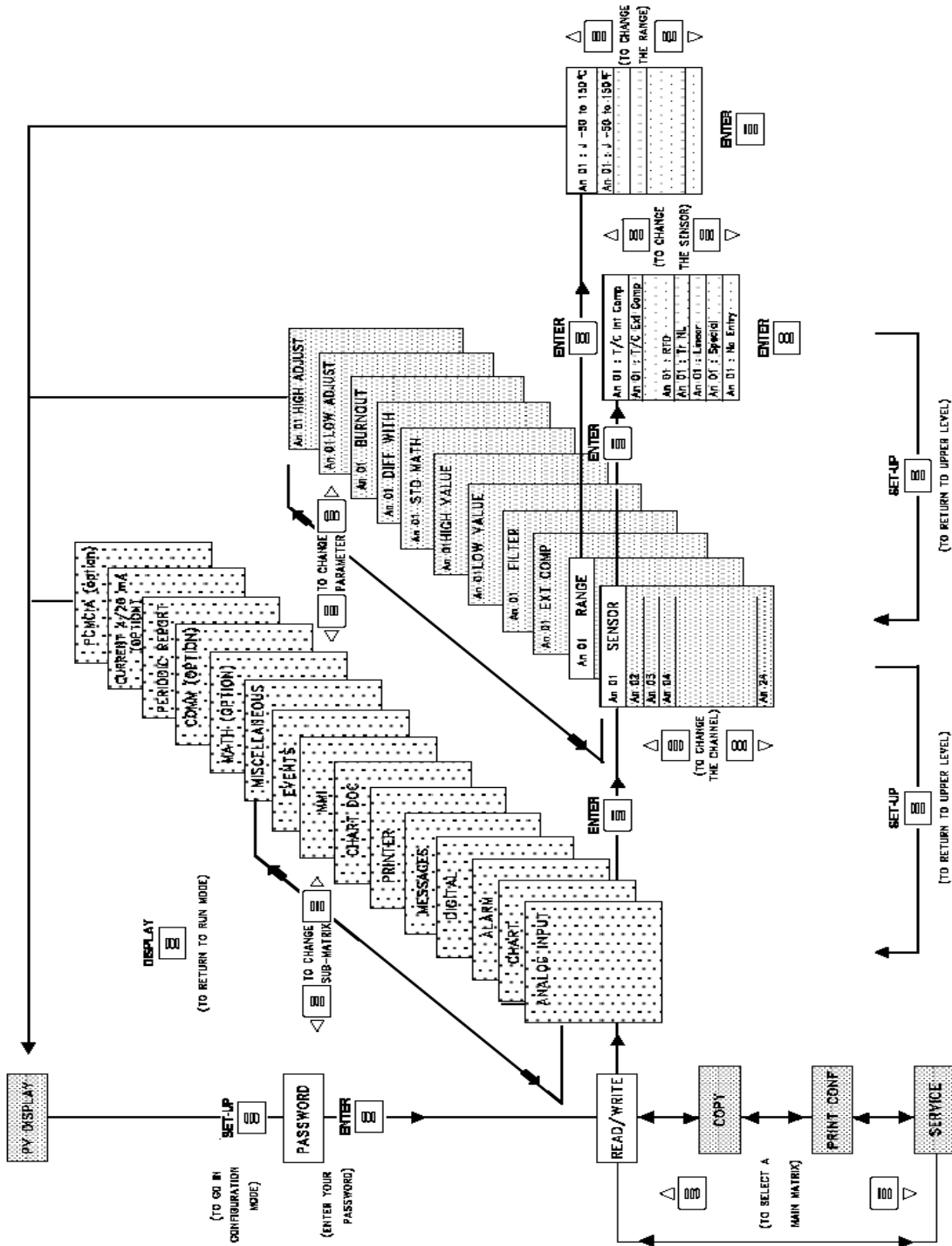



SUB - MATRIX

# **ANALOG INPUT**

Configuration of analog input parameters

PARAMETERS

**SENSOR**

page 4-7

**RANGE**

page 4-12

**EXT COMP**

page 4-13

**FILTER**

page 4-14

**LOW VALUE**

page 4-15

**HIGH VALUE**

page 4-15

**STD MATH**

page 4-16

**DIFF WITH**

page 4-17

**BURNOUT**

page 4-18

**LOW ADJUST**

page 4-19

**HIGH ADJUST**

page 4-19

## 4. CONFIGURATION

<i>SUB-MATRIX</i>	<i>PARAMETER</i>	<i>CLASSIFICATION</i>
<b>ANALOG INPUT</b>	<b>SENSOR</b>	◆◆ □□

<b>DEFINITION:</b>	Basic: sensor type used on each channel.
<b>HOW TO MODIFY IT:</b>	Select a new sensor. Press <b>ENTER</b> . With keys ▲ ▼ select the right sensor type and press <b>ENTER</b>
<b>POSSIBLE VALUES:</b>	<p><b>T/C INT COMP:</b> The sensor is a directly connected thermocouple and the cold junction compensation of the recorder is used.</p> <p><b>T/C EXT COMP:</b> Thermocouple sensor is directly connected to a remote temperature compensation box *.</p> <p>* See parameter <b>EXT COMP</b> to configure temperature or analog channels (see page 4-14) used to measure the external cold junction.</p> <p><b>RTD:</b> Sensor is a directly connected RTD or variable resistance device.</p> <p><b>TR NL 0-5V:</b> Sensor is a temperature transmitter signal range of 0-5V which is not linear with temperature.</p> <p><b>TR NL 1-5V:</b> Sensor is a temperature transmitter signal range of 1-5V which is not linear with temperature.</p> <p><b>TR NL 0-20mA :</b> Sensor is a temperature transmitter signal range of 0-20mA which is not linear with temperature.</p> <p><b>TR NL 4-20mA:</b> Sensor is a temperature transmitter signal range of 4-20mA which is not linear with temperature.</p> <p><b>LINEAR:</b> Sensor is a transmitter output which is linear with process variable.</p> <p><b>SPECIAL:</b> Special sensor connected. Must be specified by special order, or created using PC application software.</p> <p><b>NO ENTRY:</b> No sensor connected or unused input.</p>
<b>SEE ALSO:</b>	<b>RANGE</b> to select the required input range.
<b>NOTE:</b>	<p>Changing the sensor type will automatically change <b>RANGE, LOW VALUE, HIGH VALUE</b> into predefined values. Which is dependent on:</p> <ol style="list-style-type: none"><li>1) The type of analog input board installed (linear or universal)</li><li>2) If the input type is a directly connected temperature sensor.</li></ol> <p>The access to all sensors is possible only with an universal input board. <b>T/C INT COMP</b> and <b>RTD</b> sensors are not accessible with a linear input board.</p>



## 4. CONFIGURATION

---

<i>SUB-MATRIX</i>	<i>PARAMETER</i>	<i>CLASSIFICATION</i>
<b>ANALOG INPUT</b>	<b>RANGE</b>	◆◆ □□

---

**DEFINITION:**

DISPLAY ACTUATION RANGE

For directly connected temperature sensors and non-linear temperature transmitters, the actuation selection defines the linearization routine used to produce a linear chart scale. For linear transmitters, the selection simply defines the transmitter's range/span.

The choice of actuation offered by the recorder during configuration will depend upon sensor selected. The ranges allowed will depend on whether you have selected Thermocouple, Linear or Non Linear or RTD.

**HOW TO MODIFY IT:**

Select a new actuation using the ▲ or ▼ arrows and press **ENTER**

**POSSIBLE VALUES:**

Depends on the type of sensor connected. Possible selections are listed below.

## 4. CONFIGURATION

### AVAILABLE RANGES

LINEAR		RTD / OHMS			
DISPLAY	RANGE	DISPLAY	RANGE	DISPLAY	RANGE
mV: 0/10 mV -10/10 mV 0/ 20 mV -20/20 mV 0/50 mV -50/50 mV 10/50 mV 0/100 mV -100//100 mV 0/500 mV -500/500 mV	mV: 0, 10 mV -10, 0, 10 mV 0, 20 mV -20, 0, 20 mV 0, 50 mV -50, 0, 50 mV 10, 50 mV 0, 100 mV -100, 0, 100 mV 0, 500 mV -500, 0, 500 mV	Pt 100 Ω at 0 ° C -50/150 C -58/302 F 0/100 C 32/212 F 0/200 C 32/392 F 0/400 C 32/752 F -200/800 C -328/1472 F	Pt 100 Ω at 0 ° C: -50, 0, 150°C -58, 0, 302°F 0, 100°C** 32, 212°F** 0, 200°C 32, 392°F 0, 400°C 32, 752°F -200, 0, 800°C -328, 0, 1472°F	JIS: -50/150 C -58/302 F 0/100 C 32/212 F 0/200 C 32/392 F 0/400 C 32/752 F -200/500 C -328/932 F	JIS: -50, 0, 150°C -58, 0, 302°F 0, 100°C** 32, 212°F** 0, 200°C 32, 392°F 0, 400°C 32, 752°F -200, 0, 500°C -328, 0, 932°F
Volt: 0/1 V -1/1 V 0/2 V -2/2 V 0/5 V -5/5 V 1/5 V 0/10 V -10/10 V	Volt: 0, 1 V -1, 0, 1 V 0, 2 V -2, 0, 2 V 0, 5 V -5, 0, 5 V 1, 5 V 0, 10 V -10, 0, 10 V	Ni 50 ohms: 320 C 608 F  Ni 508 ohms: 150 C 302 F  Cu 10 ohms: 250 C 482 F	Ni 50 ohms: -80, 0, 320°C -112, 0, 608°F  Ni 508 ohms: -80, 0, 150°C -112, 0, 302°F  Cu 10 ohms: -20, 0, 250°C*** -4, 0, 482°F***		
mA: 0/20 mA 4/20 mA	mA: 0, 20 mA* 4, 20 mA*	Ohms: 0/200 Ω 0/2000 Ω	Ohms: 0, 200 Ω 0, 2000 Ω		

\* The mA inputs have to be connected on a 250 Ω input resistor across the input terminals.

\*\* Accuracy: 0.25 %

\*\*\* Accuracy: 0.5 %

## 4. CONFIGURATION

### AVAILABLE RANGES *(continued)*

THERMOCOUPLES						
DISPLAY	RANGE	DISPLAY	RANGE	DISPLAY	RANGE	
<b>J:</b>	<b>J:</b>	<b>S:</b>	<b>S:</b>	<b>U:</b>	<b>U:</b>	
-50/150 C	-50, 0, 150°C	0/1600 C	0, 1600°C	50/150 C	50, 0, 150°C	
-50/150 C	-50, 0, 150°C	0/1600 C	0, 1600°C	-50/150 C	-50, 0, 150°C	
-58/302 F	-58, 0, 302°F	32/2912 F	32, 2912°F	-58/302 F	-58, 0, 302°F	
0/400 C	0, 400°C	-20/1760 C	-20, 0, 1760°C	0/150 C	0, 150°C	
32/752 F	32, 752°F	-4/3200 F	-4, 0, 3200°F	32/302 F	32, 302°F	
-200/870 C	-200, 0, 870°C			50/150 C	50, 150°C	
-328/1598 F	-328, 0, 1598°F	<b>N: N:</b>		122/302 F	122, 302°F	
		0/400 C	0, 400°C	-200/400 C	-200, 0, 400°C	
<b>L: L</b>	<b>:</b>	32/752 F	32, 752°F	-328/752 F	-328, 0, 752°F	
-50/150 C	-50, 0, 150°C	0/800 C	0, 800°C			
-58/302 F	-58, 0, 302°F	32/1472 F	32, 1472°F	<b>NiMo: NiMo:</b>		
0/400 C	0, 400°C	0/1200 C	0/1200°C	0/1400 C	0, 1400°C	
32/2552 F	32, 2552°F	32/752 F	32, 752°F	32/2192 F	32, 2192°F	
-200/870 C	-200, 0, 870°C	-200/1300 C	-200, 0, 1300°C			
-328/1598 F	-328, 0, 1598°F	-328/2372 F	-328, 0, 2372°F	<b>Moco: Moco:</b>		
				0, 1400 C	0, 1400°C	
<b>K:</b>	<b>K:</b>	<b>T:</b>	<b>T:</b>	32/2552 F	32, 2552 °F	
0/400 C	0, 400°C	-50/150 C	-50, 0, 150°C			Reference
32/752 F	32, 752°F -	58/302 F	-58, 0, 302°F	<b>W-W26: W-W2</b>	<b>6:</b>	Range
0/800 C	0, 800°C	0/150 C	0, 150°C	-20/2320 C	-20, 0, 2320°C	500, 2100°C
32/1472 F	32, 1472°F	32/302 F	32, 302°F	-4/4208 F	-4, 0, 4208 °F	932, 3812 °F
0/1200 C	0, 1200°C	50/150 C	50, 150°C			
32/2192 F	32, 2192°F	122/302 F	122, 302°F	<b>W5-W26: W</b>	<b>5-W26:</b>	
		-200/400 C	-200, 0, 400°C	-20/2320 C	-20, 0, 2320°C	0, 1800°C
-200/1370 C	-200, 0, 1370°C	-328/752 F	-328, 0, 752°F	-4/4208 F	-4, 0, 4208°F	32, 3272°F
-328/2498 F	-328, 0, 2498°F					
				<b>PR20-40:</b>	<b>PR20-40:</b>	
<b>R: R:</b>						
-20/1760 C	-20, 0, 1760°C			PR20 1800C	0, 1800°C	600, 1800°C
-4/3200 F	-4, 0, 3200°F			PR20 3272 F	32, 3272°F	1110, 3300°F
				<b>B:</b>	<b>B:</b>	
				40/1820 C	400, 1820 °C	400, 1820 °C
				104/3308 F	752, 3308°F	752, 3308 °F

## 4. CONFIGURATION

---

<i>SUB-MATRIX</i>	<i>PARAMETER</i>	<i>CLASSIFICATION</i>
<b>ANALOG INPUT</b>	<b>RANGE</b>	◆◆ □□

---

**NOTE:** For non-linear signals TR NL 0 - 5 V, 1 - 5 V, 0 - 20 mA, 4 - 20 mA, 1 to 5 VDC or 4 to 20 mA or 0 to 5 VDC or 0 to 20 mA, the transmitter range must be identical to the range shown in the previous tables.

---

**NOTICE** F is used for °Fahrenheit ; C is used for °Celsius.

---

## 4. CONFIGURATION

SUB-MATRIX	PARAMETER	CLASSIFICATION
<b>ANALOG INPUT</b>	<b>EXT COMP</b>	◆◆ □□

### DEFINITION:

The thermocouple sensor is directly connected to a remote temperature compensation box. Then the connections are made with copper lead wires. Two types of wiring are possible:

- 1) At a fixed temperature compensation box with temperature configurable from 0 up to 80°C (32 to 176°F).
- 2) On variable temperature compensation box. We use 1 channel to measure the temperature of the box.

- 1) Fixed temperature compensation box

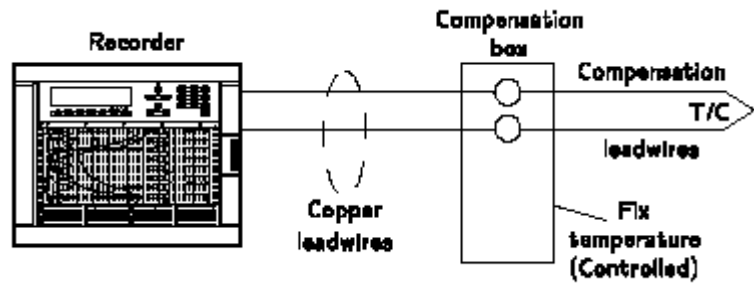

- 2) Variable temperature compensation box

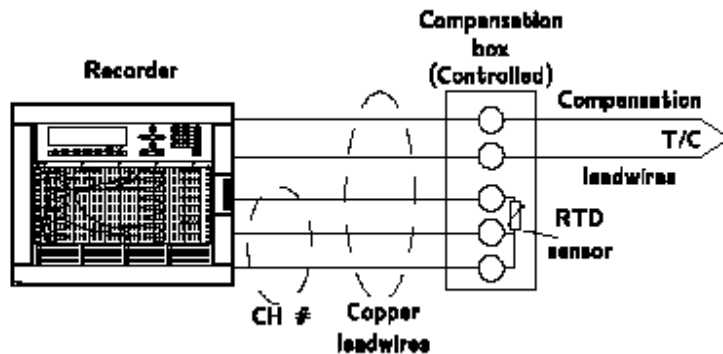

### HOW TO MODIFY IT:

- 1) Fixed Temperature: Enter a new temperature value in engineering unit. Choose between VALUE 0 and 80.
- 2) Variable Temperature: Select the channel used to measure the temperature of the box.

### NOTICE

This parameter is just taken into account if the corresponding channel is configured with T/C EXT COMP. For T/C INT COMP, RTD and LINEAR, this parameter has no effect whatever the entered value.

## 4. CONFIGURATION

SUB-MATRIX	PARAMETER	CLASSIFICATION
<b>ANALOG INPUT</b>	<b>FILTER</b>	◆◆ □

**DEFINITION:** You may wish to apply a filter to noisy signals. However if pulses, square waves or other rapidly changing inputs are to be displayed and recorded without damping, choose 0 filter value.

**HOW TO MODIFY IT:** Enter a numeric value.

**POSSIBLE VALUES:** 0-99 seconds

0 = No filter

10 = 10 seconds

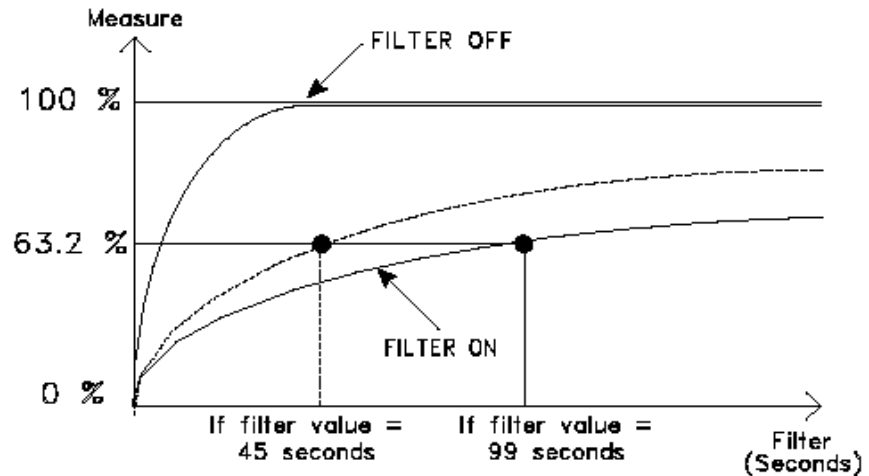

### NOTICE

All the alarms or maths functions configured on a filtered analog input are affected by the filter delay. Be mindful with the filter action for the channels on which a "rate of change" alarm is configured: the filter can suppress the alarm action.

## 4. CONFIGURATION

---

<i>SUB-MATRIX</i>	<i>PARAMETER</i>	<i>CLASSIFICATION</i>
<b>ANALOG INPUT</b>	<b>LOW VALUE</b>	◆◆ □

---

**DEFINITION:** Engineering value corresponding to low limit of the selected input actuation range.

**HOW TO MODIFY IT:** Enter a numeric value.

**POSSIBLE VALUES:** Up to 4 digits plus optional sign.  
[-9999 ... 9999]

---

**NOTICE** Modification is not allowed for any directly connected temperature sensors, as this would adversely affect the linearization.  
Modification is only possible when the sensor is:  
- LINEAR or SPECIAL  
- RTD and the range is 0, 200 Ohms or 0, 2000 Ohms

---

**NOTICE** For linear and non-linear transmitters choose the value in engineering units, which corresponds to the low range limit of the transmitter.

---

---

<i>SUB-MATRIX</i>	<i>PARAMETER</i>	<i>CLASSIFICATION</i>
<b>ANALOG INPUT</b>	<b>HIGH VALUE</b>	◆◆ □

---

**DEFINITION:** Engineering value corresponding to high limit of the selected input actuation range.

**HOW TO MODIFY IT:** Enter a numeric value.

**POSSIBLE VALUES:** Up to 4 digits plus optional sign.  
[-9999 ... 9999]

---

**NOTICE** Modification is not allowed for any directly connected temperature sensors, as this would adversely affect the linearization.  
Modification is only possible when the sensor is:  
- LINEAR or SPECIAL  
- RTD and the range is 0, 200 Ohms or 0, 2000 Ohms

---

**NOTICE** For linear and non-linear transmitters choose the value in engineering units, which corresponds to the low range limit of the transmitter.

---

## 4. CONFIGURATION

SUB-MATRIX	PARAMETER	CLASSIFICATION
<b>ANALOG INPUT</b>	<b>STD MATH</b>	◆◆ □□

**DEFINITION:** 2 mathematical functions are included as standard in the recorder. These functions apply only to analog inputs.

**HOW TO MODIFY IT:** Select the maths function.

**POSSIBLE CHOICES:** **NO OPT MATH:** No maths function configured.

**SQUARE ROOT:** Square root applies to analog input.

**CHANNEL DIFF:** Difference between the current analog input and the one configured in "DIFF WITH".

**SEE ALSO:** **DIFF WITH** in this sub-matrix for **CHANNEL DIFF**.

**NOTE:** 1) For **SQUARE ROOT** the formula is:

$$PV = \sqrt{\frac{(S - S_{min}) (HIGH VAL^2 - LOW VAL^2)}{(S_{max} - S_{min})}} + LOW VAL^2$$

**S<sub>min</sub>** = min. sensor input value

**S<sub>max</sub>** = max. sensor input value

**S** = current sensor input value

Available for linear inputs

2) For **CHANNEL DIFF**, the formula is:

$$PV = PVA - PVB$$

A and B are any analog input.



## 4. CONFIGURATION

---

<i>SUB-MATRIX</i>	<i>PARAMETER</i>	<i>CLASSIFICATION</i>
<b>ANALOG INPUT</b>	<b>DIFF WITH</b>	◆◆ □□

---

**DEFINITION:** Second channel used when **STD MATH = CHANNEL DIFF**

**HOW TO MODIFY IT:** Select a new value.

**POSSIBLE CHOICES:** **ANALOG # i (i = 1 ... 64)**

**NONE**

**NOTE:** The software will only allow selection of pre-configured input.

For the difference between 2 channels, it is recommended to take first the highest channel reference and subtract from the other channel.  
Example:  
You want to make a difference between channels 7 and 12:  
make ch12 minus ch7.

---

## 4. CONFIGURATION

SUB-MATRIX	PARAMETER	CLASSIFICATION
<b>ANALOG INPUT</b>	<b>BURNOUT</b>	◆◆ □□

**DEFINITION:** Allows you to define the safety backup position to activate alarms (if configured) in case of sensor burnout. The trace can go either on the right (high) or on the left (low).

**HOW TO MODIFY IT:** Select new text.

**POSSIBLE CHOICES:** **NO BURNOUT:** No burnout.

**B OUT LOW:** Burnout configured low scale. Display shows [-9999]

**B OUT HIGH:** Burnout configured high scale. Display shows [9999]

**FIX LOW:** Value fixed low. (mA) Not configurable

**FIX HIGH:** Value fixed high. (RTD/OHMS) Not configurable

**FIX NONE:** Undefined value. Not configurable (Linear sensors)  
0 to 10 V / - 5 to 5 V / -1 to 1 V / -500 to 500 mV

**NOTE:**

- For some sensors (mA, RTD, Volts), burnout is not configurable but fixed and display will show **FIX LOW**, **FIX HIGH** or **FIX NONE**. The value will be out of range (low, high or undefined). The "BURNOUT" event is only activated with the **B OUT LOW** or **B OUT HIGH** configuration.
- For RTD/OHMS sensors, a third wire burnout cannot be detected: the output value will be undefined.



### CAUTION

For configurable burnout, be aware that a current pulse of 0.125 mA will occur regularly as part of the burnout detection and may disturb other devices connected to the same sensor. For an application with another controller connected on the same current loop, please remove the burnout detection on your recorder.

Failure to comply with these instructions may result in product damage

## 4. CONFIGURATION

SUB-MATRIX	PARAMETER	CLASSIFICATION
ANALOG INPUT	<b>LOW ADJUST HIGH ADJUST</b>	◆◆ □

**DEFINITION:**

Zero adjust and span adjust are values used to calibrate a temperature loop. Otherwise choose 0 Value = Factory Calibration  
Adjustments are made directly in Engineering unit to the input range.  
(ex.: 5 = 5°C)

**HOW TO MODIFY IT:**

Enter a numeric value.

**POSSIBLE CHOICES:**

Up to 3 digits including negative sign and decimal point.  
[-99 ... +99]

**EXAMPLE:**

**LOW ADJUST** will be added to the 0% of the considered range.  
**HIGH ADJUST** will be added to the 100% of the considered range, so the calibration is changed.

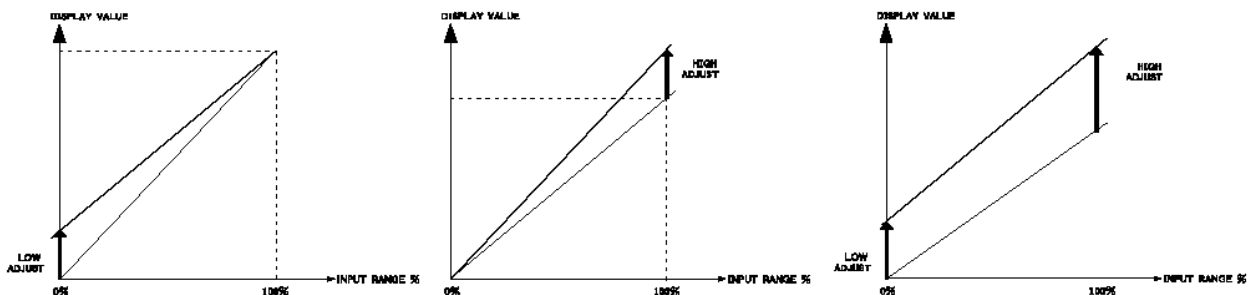

# 4. CONFIGURATION

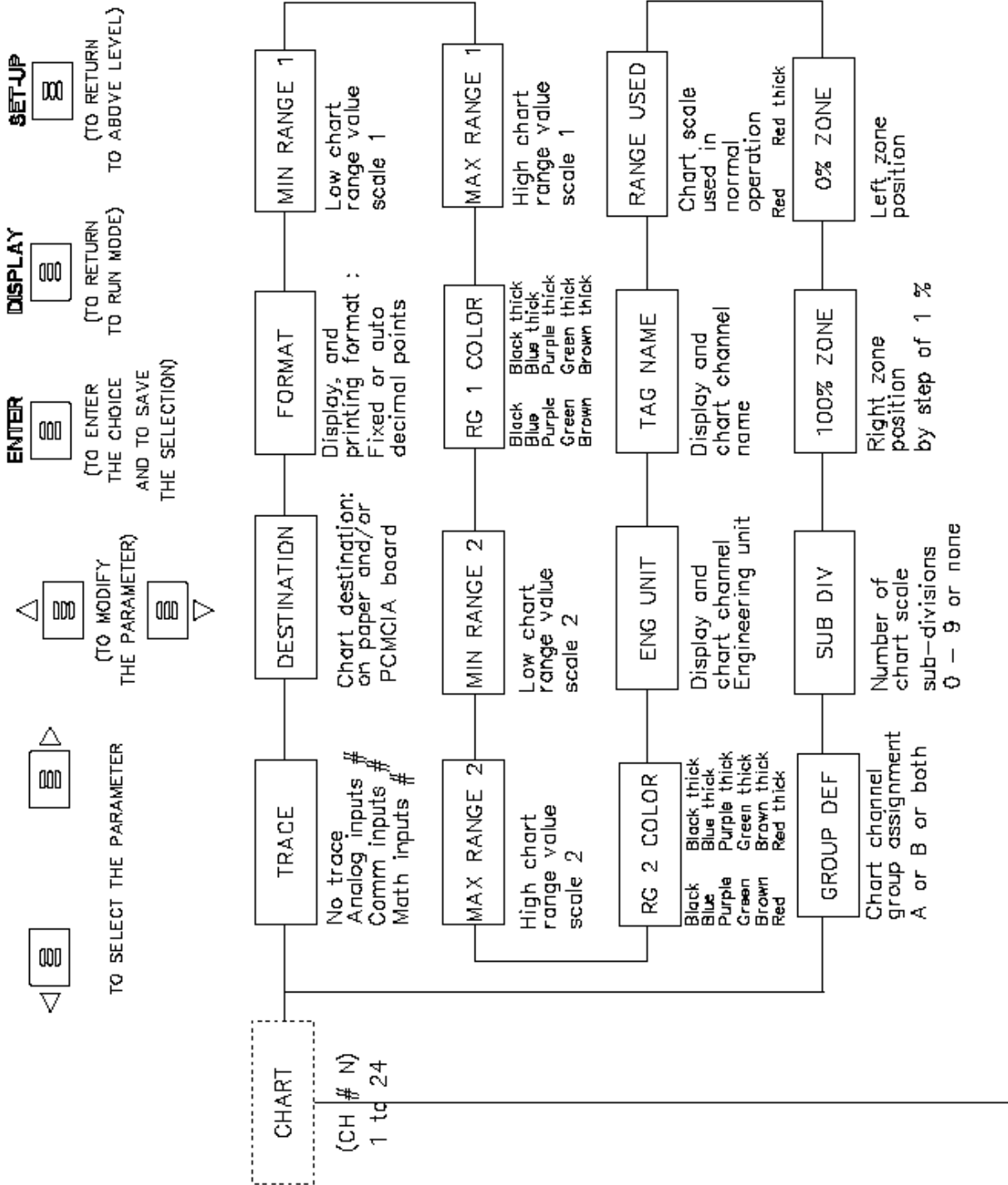

### SUB – MATRIX PARAMETERS

## CHART

Configuration of chart range and format

<b>TRACE</b>	page 4-21
<b>DESTINATION</b>	page 4-21
<b>FORMAT</b>	page 4-22
<b>MIN RANGE 1</b>	page 4-22
<b>MAX RANGE 1</b>	page 4-23
<b>RG 1 COLOR</b>	page 4-23
<b>MIN RANGE 2</b>	page 4-24
<b>MAX RANGE 2</b>	page 4-24
<b>RG 2 COLOR</b>	page 4-25
<b>ENG UNIT</b>	page 4-25
<b>TAG NAME</b>	page 4-26
<b>RANGE USED</b>	page 4-26
<b>0% ZONE</b>	page 4-27
<b>100% ZONE</b>	page 4-27
<b>SUB DIV</b>	page 4-28
<b>GROUP DEF</b>	page 4-29

## 4. CONFIGURATION

---

SUB-MATRIX

PARAMETER

CLASSIFICATION

**CHART**

**TRACE**



**DEFINITION:**

Defines the variable to be printed on the chart or stored on the PCMCIA memory card (None, Analog input 1... 24, Comm input 1 ... 24, maths input 1 ... 24).

**HOW TO MODIFY IT:**

Select a new value.

**POSSIBLE CHOICES:**

**NO TRACE**

**ANALOG # i (i = 1 ... 64)**

**COMM # i (i = 1 ... 32)**

**MATH # i (i = 1 ... 32)**

---

### NOTICE

The software will only allow selection of a pre-configured analog input.

---

SUB-MATRIX

PARAMETER

CLASSIFICATION

**CHART**

**DESTINATION**



**DEFINITION:**

Determines where to print or copy charts.

**HOW TO MODIFY IT:**

Select a new value.

**POSSIBLE CHOICES:**

**ON PAPER**

**ON FILE \***

**PAPER & FILE \***

\* **FILE:** this corresponds to the trace storage on a PCMCIA memory card.

**DEFAULT VALUE:**

**ON PAPER**

---

## 4. CONFIGURATION

---

SUB-MATRIX	PARAMETER	CLASSIFICATION
CHART	FORMAT	◆ □ □

---

**DEFINITION:** Format used for the printing of trend, range and information, and the display of trace value.

**POSSIBLE CHOICES:** XXXXX (no decimal point) 10000  
XXX.X (1/10) 100.0  
XX.XX (1/100) 10.00  
X.XXX (1/1000) 1.000  
**AUTOMATIC:** Automatically displays and prints the measured value based on the accuracy of the recorder and the available number of digits on the display. IE ACCURACY = 0.1% on selected ranges.

---

SUB-MATRIX	PARAMETER	CLASSIFICATION
CHART	MIN RANGE 1	◆ ◆ □

---

**DEFINITION:** Lower limit of chart range 1.

**HOW TO MODIFY IT:** Enter a numeric value.

**POSSIBLE VALUES:** Up to 8 digits for analog inputs, maths results and comm. results. Including negative sign and decimal point.

**EXAMPLE:**

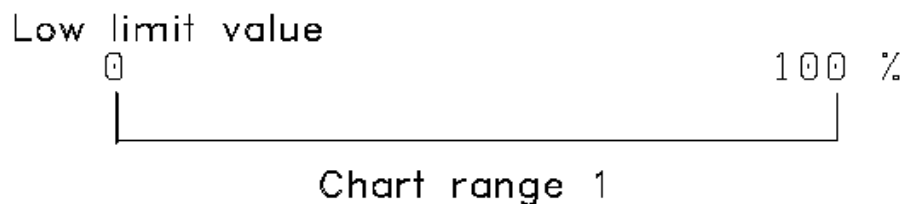

---

## 4. CONFIGURATION

SUB-MATRIX

PARAMETER

CLASSIFICATION

**CHART**

**MAX RANGE 1**



**DEFINITION:** Upper limit of chart range 1

**HOW TO MODIFY IT:** Enter a numeric value.

**POSSIBLE VALUES:** Up to 8 digits for analog inputs, maths results and comm. results. Including negative sign and decimal point.

**EXAMPLE:**



SUB-MATRIX

PARAMETER

CLASSIFICATION

**CHART**

**RG1 COLOR**



**DEFINITION:** Color of range 1.

**HOW TO MODIFY IT:** Select a new color

**POSSIBLE VALUES:**

- BLACK
- BLUE
- PURPLE
- GREEN
- BROWN
- RED
- BLACK THICK
- BLUE THICK
- PURPLE THICK
- GREEN THICK
- BROWN THICK
- RED THICK



## 4. CONFIGURATION

SUB-MATRIX	PARAMETER	CLASSIFICATION
CHART	MIN RANGE 2	◆◆ □

**DEFINITION:** Lower limit of chart range 2.

**HOW TO MODIFY IT:** Enter a numeric value.

**POSSIBLE VALUES:** Up to 8 digits for analog inputs, maths results and comm. results. Including negative sign and decimal point.

**EXAMPLE:**

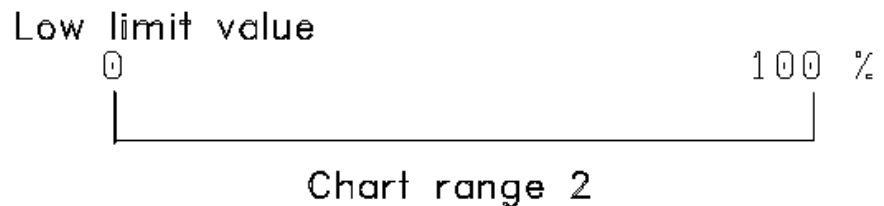

SUB-MATRIX	PARAMETER	CLASSIFICATION
CHART	MAX RANGE 2	◆◆ □

**DEFINITION:** Upper limit of chart range 2

**HOW TO MODIFY IT:** Enter a numeric value.

**POSSIBLE VALUES:** Up to 8 digits for analog inputs, maths results and comm. results. Including negative sign and decimal point.

**EXAMPLE:**

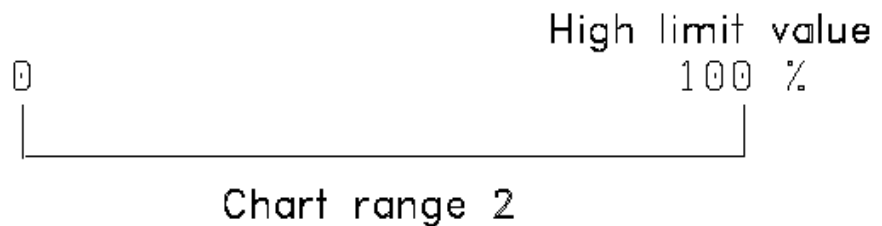

## 4. CONFIGURATION

<i>SUB-MATRIX</i>	<i>PARAMETER</i>	<i>CLASSIFICATION</i>
<b>CHART</b>	<b>RG2 COLOR</b>	◆ □

**DEFINITION:** Color of range 2.

**HOW TO MODIFY IT:** Select a new color

**POSSIBLE VALUES:** BLACK  
BLUE  
PURPLE  
GREEN  
BROWN  
RED  
BLACK THICK  
BLUE THICK  
PURPLE THICK  
GREEN THICK  
BROWN THICK  
RED THICK

<i>SUB-MATRIX</i>	<i>PARAMETER</i>	<i>CLASSIFICATION</i>
<b>CHART</b>	<b>ENG UNIT</b>	◆ □

**DEFINITION:** Chart channel units.

**HOW TO MODIFY IT:** Enter a text.

**POSSIBLE CHOICES:** 5 alpha numerical characters max.

**EXAMPLES:**

- mm/h
- Deg F
- Deg C
- PSI
- BAR
- $\mu$ A

### NOTICE

When PCMCIA option is configured any modifications of ENG UNIT parameter will be forbidden while storage is running.  
Refer to the PCMCIA Option Manual for more details.

## 4. CONFIGURATION

---

<i>SUB-MATRIX</i>	<i>PARAMETER</i>	<i>CLASSIFICATION</i>
<b>CHART</b>	<b>TAG NAME</b>	◆ □

---

**DEFINITION:** Name of the chart channel.

**HOW TO MODIFY IT:** Enter a text.

**POSSIBLE CHOICES:** 8 alpha numerical characters.

**EXAMPLES:**

- REACTOR
- FURNACE
- AUTOCLAV

---

**NOTICE** When PCMCIA option is configured any modifications of TAG NAME parameter will be forbidden while storage is running. Refer to the PCMCIA Option Manual for more details.

---

---

<i>SUB-MATRIX</i>	<i>PARAMETER</i>	<i>CLASSIFICATION</i>
<b>CHART</b>	<b>RANGE USED</b>	◆◆ □□

---

**DEFINITION:** You may select whether the input channel will be printed normally (range 1 or 2) or on alarm (with range 1 or 2).

**HOW TO MODIFY IT:** Select a new value.

**POSSIBLE CHOICES:**

WITH RG1  
WITH RG2

}

NOTE:

Select the range used in normal printing.

RG1 ON ALARM  
RG2 ON ALARM

}

Only if you have selected " **PRINT ON AL**" in sub-matrix **ALARM** you have to select the **RG1 ON ALARM** or **RG2 ON ALARM**

**SEE ALSO:** Parameter **ACTION** in **ALARM** sub-matrix.  
Parameter **ACTION** in **DIGITAL** sub-matrix.  
Parameter **GROUP DEF** in **CHART** sub-matrix.

---

## 4. CONFIGURATION

SUB-MATRIX	PARAMETER	CLASSIFICATION
CHART	<b>0% ZONE</b> <b>100% ZONE</b>	◆◆□
<b>DEFINITION:</b>	Defines chart zone for printing.	
<b>HOW TO MODIFY IT:</b>	Enter a new value.	
<b>POSSIBLE CHOICES:</b>	<p>0...100% - - - - &gt; 0...80% for 0% zone of paper - - - - &gt; 20...100% for 100% zone</p> <p>The choice of parameters for 0% and 100% zone allows you to define the datum such that the width of the chart paper is less than the calibrated width of the paper.</p> <p>This function permits the segregation of input traces into zones to avoid the problem of input signals using the same paper scale and having the same values printed on top of each other.</p> <p>The minimum width per zone is 20% of the chart.</p>	
<b>NOTE:</b>	The zoning is only possible in <b>TREND</b> mode.	
<b>SEE ALSO:</b>	<b>PRINTER</b> matrix and <b>PRINT MODE</b> parameter. <b>SUB DIV = NO DIVISION</b> when zoning is < 100%	

SUB-MATRIX	PARAMETER	CLASSIFICATION
CHART	<b>0% ZONE</b> <b>100% ZONE</b>	◆◆□

**EXAMPLE:**

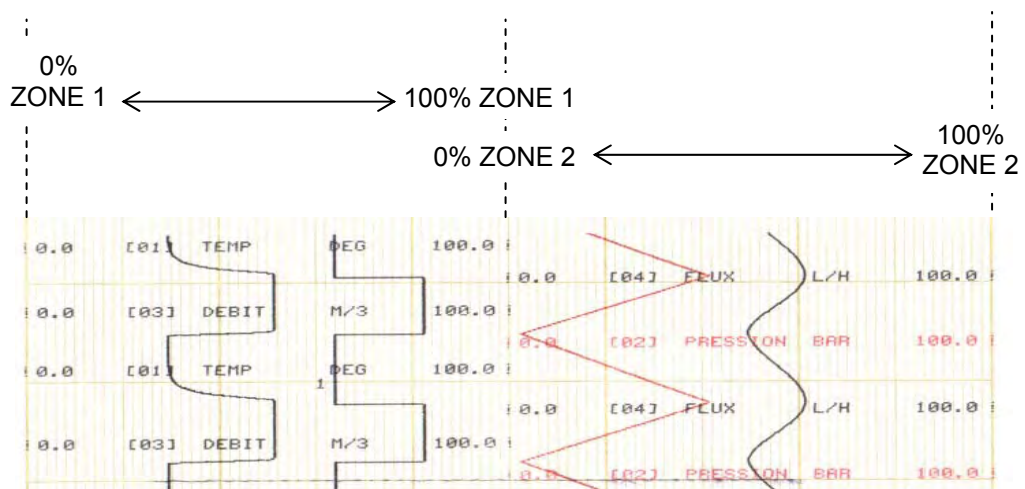

## 4. CONFIGURATION

SUB-MATRIX

PARAMETER

CLASSIFICATION

CHART

SUB DIV



**DEFINITION:** This parameter allows the visualization of a scale on the paper in addition to the classic **RANGE** message.  
Refer to the **CHART DOC** matrix, **INFORMATION #** parameter.

**POSSIBLE CHOICES:** **NO DIVISION:** Standard **RANGE** message.  
Example: Chart scale printed in 1 line.

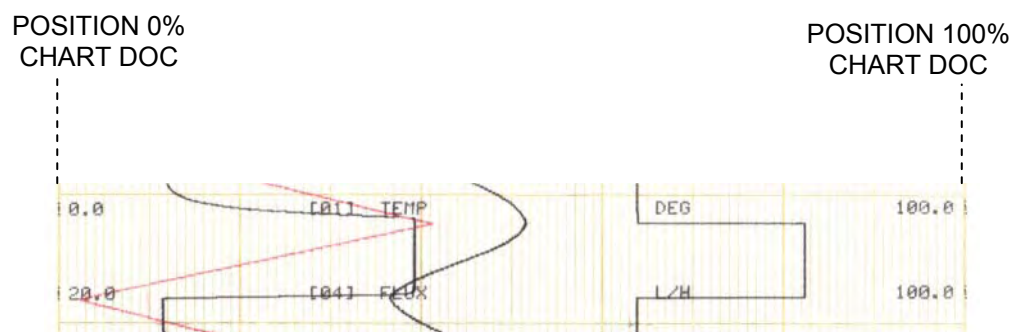

**DIVISION:** Subdivisions (Configurable from 0 to 9) to be printed in **RANGE** scale printing.  
Example: Chart scale printed in 2 lines. 3 subdivisions, 2 lines printing.

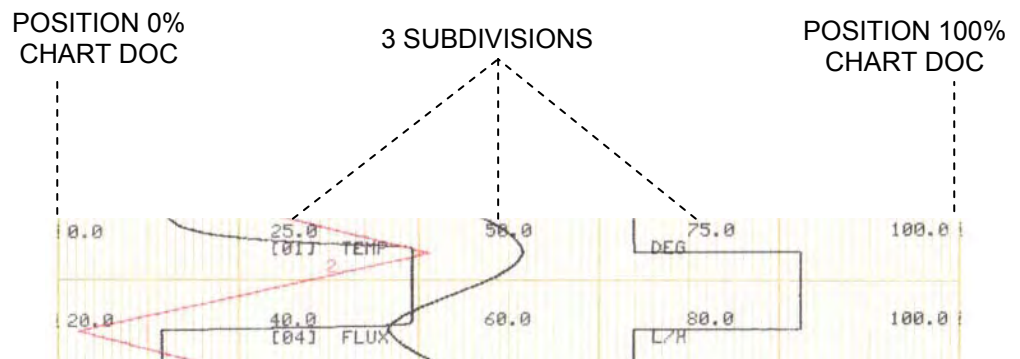

**SEE ALSO:** See **INFORMATION** parameter in **CHART DOC** sub-matrix, with **RANGE** choice.

**NOTICE** In **ZONING** mode (**0% ZONE ! 0** and **100% ZONE ! 100**), the **SUB DIV** parameter is considered as equivalent to **NO DIVISION**.

## 4. CONFIGURATION

---

SUB-MATRIX

PARAMETER

CLASSIFICATION

---

**CHART**

**GROUP DEF**



---

**DEFINITION:** This defines two separate groups of channels that will be printed together as a group

**POSSIBLE CHOICES:** **NO GROUP:** Trace not affected by **CHG GROUP** action.  
Prints all configured channels  
**GROUP A:** Trace affected by **CHG GROUP** action.  
Channels only in GROUP A  
**GROUP B:** Trace affected by **CHG GROUP** action.  
Channels only in GROUP B

**SEE ALSO:** See **ALARM** and **DIGITAL INPUTS** sub-matrices, **ACTION** parameter, **PRINT GROUP** choice.

---

# 4. CONFIGURATION

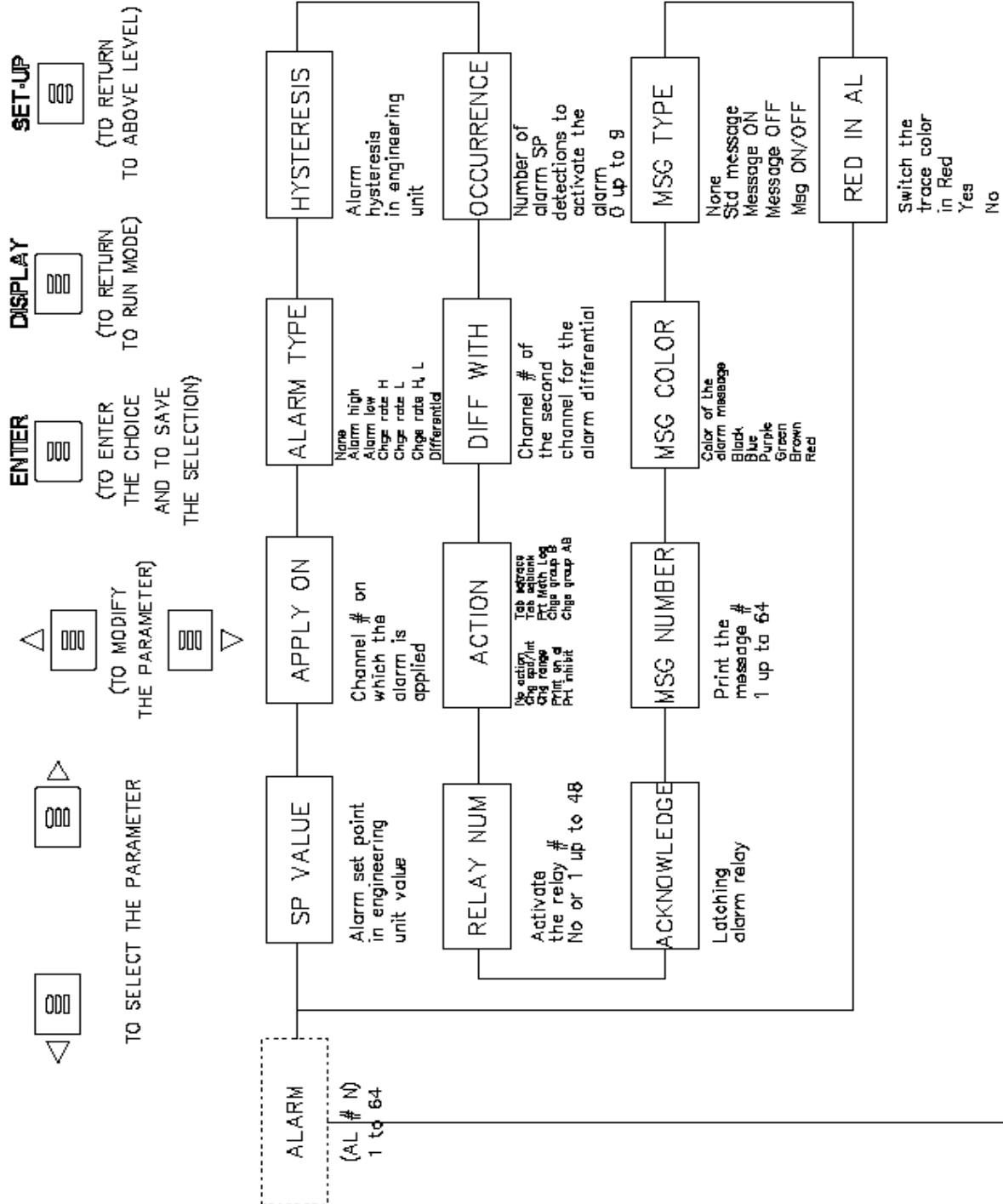

### SUB – MATRIX

# ALARM

Configuration of alarm set point with its action

### PARAMETERS

<b>SP VALUE</b>	page 4-32
<b>APPLY ON</b>	page 4-32
<b>ALARM TYPE</b>	page 4-33
<b>HYSTERESIS</b>	page 4-35
<b>OCCURRENCE</b>	page 4-36
<b>DIFF WITH</b>	page 4-38
<b>ACTION</b>	page 4-39
<b>RELAY NUM</b>	page 4-40
<b>ACKNOWLEDGE</b>	page 4-40
<b>MSG NUMBER</b>	page 4-41
<b>MSG COLOR</b>	page 4-41
<b>MSG TYPE</b>	page 4-42
<b>RED IN AL</b>	page 4-45



## 4. CONFIGURATION

SUB-MATRIX	PARAMETER	CLASSIFICATION
ALARM	SP VALUE	◆□

**DEFINITION:** The alarm switches from OFF to ON when the SP value is reached.

**HOW TO MODIFY IT:** Enter a numeric value.

**POSSIBLE VALUES:** Up to 7 digits plus optional sign and decimal point in various engineering units, depending on the channel type.  
[-9999999 ... 9999999]  
3 digits after the decimal point available

**SEE ALSO:** ALARM TYPE in the same sub-matrix.

**EXAMPLE:** High alarm type:

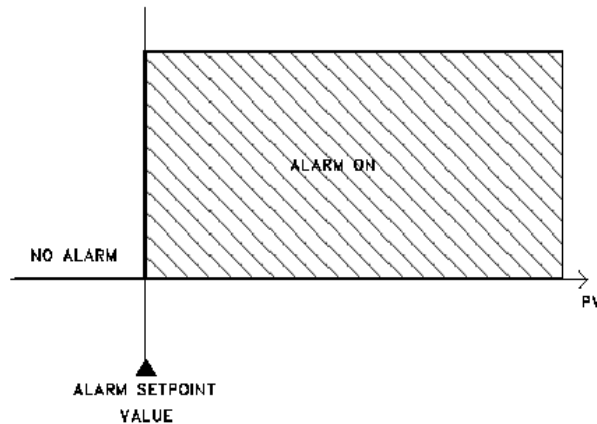

SUB-MATRIX	PARAMETER	CLASSIFICATION
ALARM	APPLY ON	◆◆□□

**DEFINITION:** Channel on which the alarm is applied (Analog 1 ... 64, Comm 1 ... 32, maths 1 ... 32).

**POSSIBLE CHOICES:** Select a new value.

**SEE ALSO:** ANALOG # i (i = 1 ... 64)  
COMM # i (i = 1 ... 32)  
MATH # i (i = 1 ... 32)

## 4. CONFIGURATION

SUB-MATRIX	PARAMETER	CLASSIFICATION
<b>ALARM</b>	<b>ALARM TYPE</b>	◆◆□□

**DEFINITION:** Type of alarm

**HOW TO MODIFY IT:** Select a new alarm type.

**POSSIBLE VALUES:** **NONE:** Select "none" for unused alarms.

**ALARM HIGH:** Alarm to occur when the value equals or exceeds the alarm setpoint.

**ALARM LOW:** Alarm to occur when the value equals or is below the alarm setpoint.

**CHG RATE H:** Alarm to occur if the trace increases quicker than the alarm setting. The SP value used is the absolute value of the input value. (setpoint is given in engineering unit/second)

**CHG RATE L:** Alarm to occur if the trace decreases quicker than the alarm setting. The SP value used is the absolute value of the input value. (setpoint is given in engineering unit/second)

**CHG RATE H, L:** Alarm to occur if the trace increases/decreases quicker than the alarm setting. The SP value used is the absolute value of the input value. (setpoint is given in engineering unit/second)

**DIFFERENTIAL:** Occurs if the absolute difference between the values of the specified channel and a second channel exceeds the absolute value of the alarm setpoint.

**SEE ALSO:** **DIFF WITH** for **DIFFERENTIAL** in this sub-matrix.

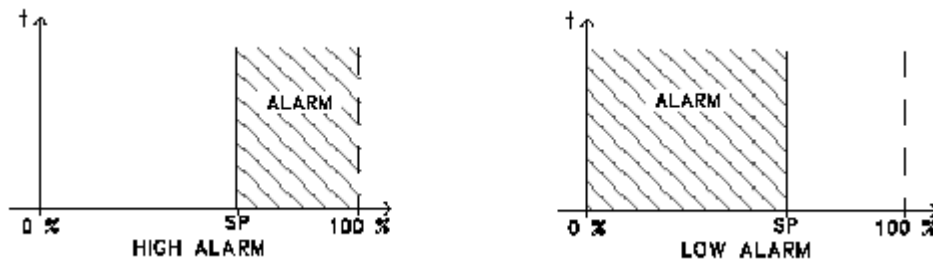

## 4. CONFIGURATION

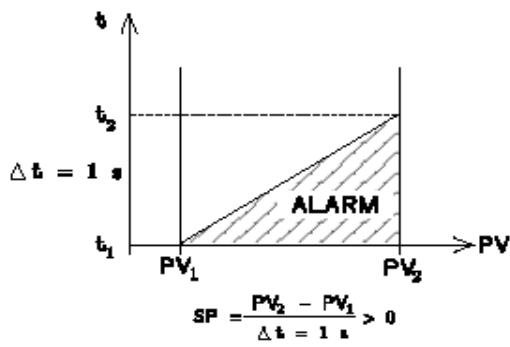

CHG RATE HIGH

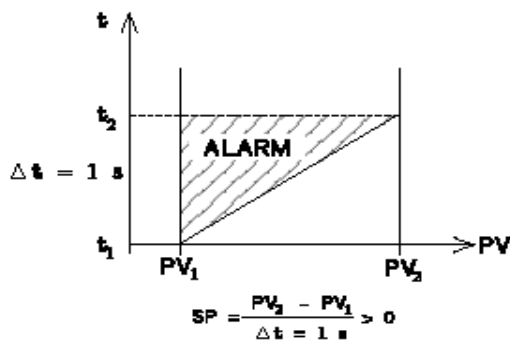
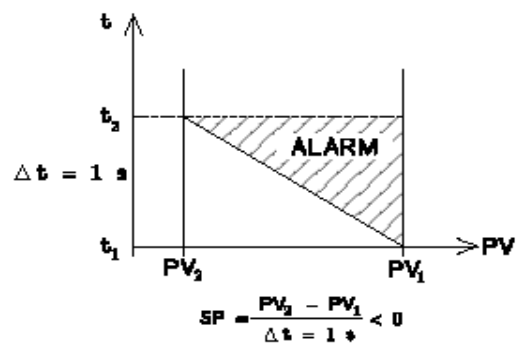

CHG RATE LOW

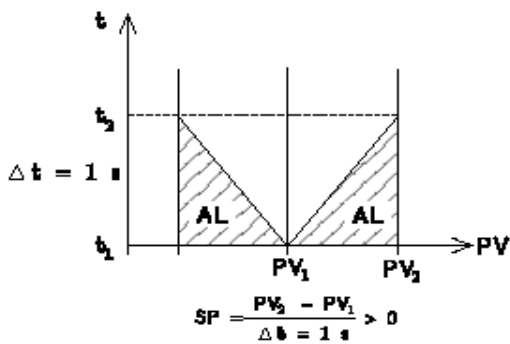
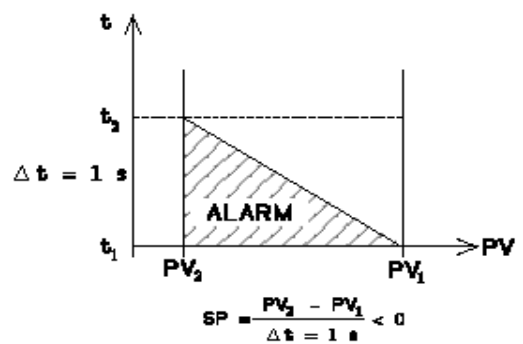

CHG RATE H, L

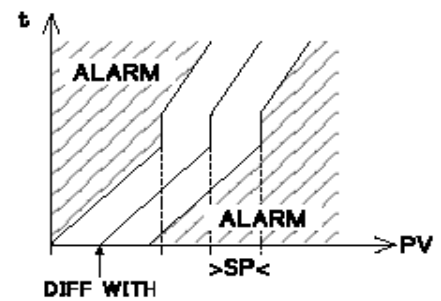

DIFFERENTIAL

## 4. CONFIGURATION

SUB-MATRIX

PARAMETER

CLASSIFICATION

**ALARM**

**HYSTERESIS**



**DEFINITION:** Establishes the alarm hysteresis. Alarms switch ON at set point but switch OFF value depends on the hysteresis setting.

Hysteresis is expressed in Engineering units and is added to low alarm and subtracted from high alarm set points to establish the alarm release value.

**HOW TO MODIFY:** Enter a numeric value of up to 3 digits, with optional decimal point.

**POSSIBLE VALUES** [0.0 ... 999] (including decimal point)  
3 digits after the decimal point available

**EXAMPLE:**

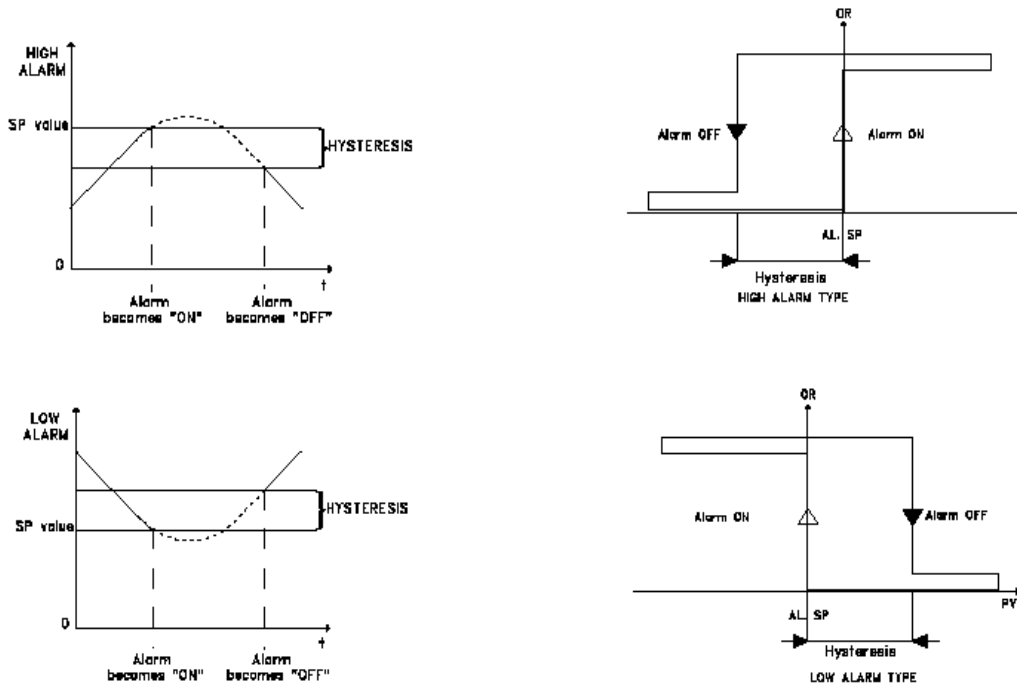

**NOTE:** With CHG rate type, this parameter is expressed in Engineering units.

## 4. CONFIGURATION

---

<i>SUB-MATRIX</i>	<i>PARAMETER</i>	<i>CLASSIFICATION</i>
<b>ALARM</b>	<b>OCCURRENCE</b>	◆◆□□

---

**DEFINITION:** Defines the number of alarm occurrences that must occur after power on before alarm activation can actually operate. This acts as a filter for the alarm activation.

**HOW TO MODIFY IT:** Select a new value.

**POSSIBLE VALUES:** [0 ... 9]  
**0 = No alarm occurrence (ie: normal alarm activation)**  
**1 = 1 alarm occurrence**  
**2 = 2 alarm occurrences**  
.  
.  
.  
**9 = 9 alarm occurrences**

**EXAMPLE:** High alarm type configured with alarm occurrence = 1  
At start up (power on) PV < SP, the alarm is inactive.  
The first alarm (occurrence #1) is disregarded, the second alarm causes the alarm to be activated.

---

## 4. CONFIGURATION

SUB-MATRIX

PARAMETER



CLASSIFICATION

ALARM

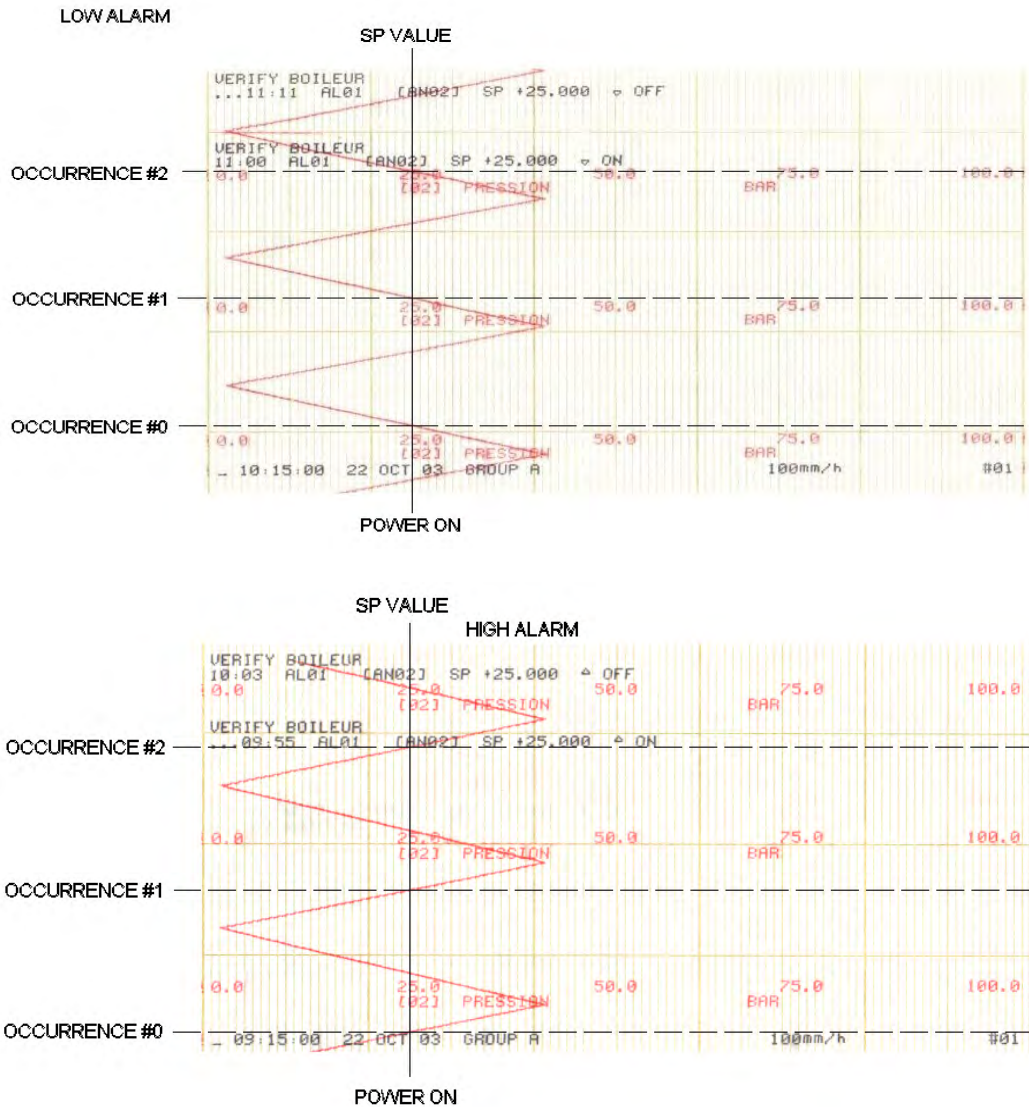
OCCURRENCE



Occurrence value is reset to the configured value after:

- Power on
- Entering in configuration mode (selection of any parameter marked with , see page 4-2).
- An immediate action RESET OCCURRENCE

## 4. CONFIGURATION

---

<i>SUB-MATRIX</i>	<i>PARAMETER</i>	<i>CLASSIFICATION</i>
<b>ALARM</b>	<b>DIFF WITH</b>	◆◆□□

---

**DEFINITION:** Second channel used if alarm type is differential.

**HOW TO MODIFY IT:** Select a new value.

**POSSIBLE VALUES:** The same as those for alarm channel.  
**ANALOG # i** (i = 1 ... 64)  
**COMM # i** (i = 1 ... 32)  
**MATH # i** (i = 1 ... 32)

**NOTE:** For the difference between 2 channels, it is recommended to take first the highest channel reference and subtract from the other channel.  
Example:  
You want to make a difference between channels 7 and 12: make ch12 minus ch7.

---

## 4. CONFIGURATION

---

SUB-MATRIX

PARAMETER

CLASSIFICATION

**ALARM**

**ACTION**



<b>DEFINITION:</b>	Action on printer in case of alarm.
<b>HOW TO MODIFY IT:</b>	Select a new alarm action.
<b>POSSIBLE VALUES:</b>	<p><b>NO ACTION:</b> No effect on printing.</p> <p><b>CHG SPD/INT:</b> Change chart speed/print interval.</p> <p><b>CHG RANGE:</b> Change to range 2 if <b>RANGE USED</b> = with R1 and to range 1 if <b>RANGE USED</b> = with R2</p> <p><b>PRINT ON AL:</b> Prints the channel trace when alarm condition occurs.</p> <p><b>PRT INHIBIT:</b> Stop all printing without data acquisition.</p> <p><b>TAB SQTRACE:</b> Print one tabular snapshot of values superimposed on traces.</p> <p><b>TAB SQBLANK:</b> Print one tabular snapshot of values on blank paper.</p> <p><b>PRT MATH LOG:</b> Print one tabular snapshot of maths results.</p> <p><b>CHG GROUP B:</b> CHG GROUP A to B: Print groups # i of channels defined in <b>CHART</b> sub-matrix. When the alarm turns ON, the group B is printed. When the alarm turns OFF, the group A is printed.</p> <p><b>CHG GROUP AB:</b> CHG GROUP A to A + B: Print groups # i of channels defined in <b>CHART</b> sub-matrix. When the alarm turns ON, groups A and B are printed. When the alarm turns OFF, the group A is printed.</p>
<b>SEE ALSO:</b>	<p><b>RANGE USED</b> in <b>CHART</b> sub-matrix for <b>PRINT ON AL</b> and <b>CHG GROUP</b></p> <p><b>GROUP DEF</b> in <b>CHART</b> sub-matrix for <b>CHG GROUP</b></p>

---



## 4. CONFIGURATION

SUB-MATRIX	PARAMETER	CLASSIFICATION
ALARM	RELAY NUM	◆◆□□

**DEFINITION:** Selection of the relay to activate in alarm condition.

**HOW TO MODIFY IT:** Select a new relay number.

**POSSIBLE CHOICES:** NO RELAY

RELAY # i (i = 1 ... 48)

SUB-MATRIX	PARAMETER	CLASSIFICATION
ALARM	ACKNOWLEDGE	◆◆□□

**DEFINITION:** To acknowledge all alarm relay outputs.

**POSSIBLE CHOICES:** **ENABLE:** Requires alarm acknowledgment to release all alarm relays  
**DISABLE:** Normal alarm relay operation (no latching relay)

**EXAMPLE:** Of alarm relay operation with Alarm acknowledge enable

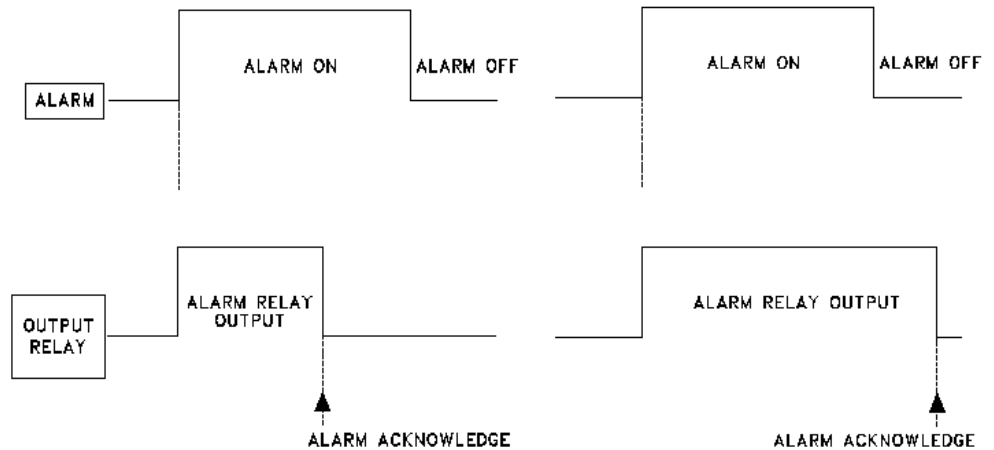

**NOTICE** If **ACKNOWLEDGE** is **ENABLE**, the parameter **ACK KEY** must also be enabled in sub-matrix **MMI**.

## 4. CONFIGURATION

---

SUB-MATRIX

PARAMETER

CLASSIFICATION

**ALARM**

**MSG NUMBER**



**DEFINITION:** Selection of the alarm message to be printed.

**HOW TO MODIFY IT:** Select a new message number.

**POSSIBLE VALUES:** MESSAGE # i (i = 1 ... 64)

**SEE ALSO:** MSG TYPE in this sub-matrix

**NOTICE** Be sure the selected message is already configured.  
(See Matrix Message)

---

SUB-MATRIX

PARAMETER

CLASSIFICATION

**ALARM**

**MSG COLOR**



**DEFINITION:** Color of alarm message.

**HOW TO MODIFY IT:** Select a new color.

**POSSIBLE VALUES:** BLACK  
BLUE  
PURPLE  
GREEN  
BROWN  
RED

---

## 4. CONFIGURATION

---

<i>SUB-MATRIX</i>	<i>PARAMETER</i>	<i>CLASSIFICATION</i>
<b>ALARM</b>	<b>MSG TYPE</b>	◆□□

---

**DEFINITION:** Defines when the alarm message is printed.

**HOW TO MODIFY IT:** Select a new message type.

**POSSIBLE CHOICES:** **NONE:** The standard message (time, alarm type ...), and the operator message are not printed.

**STD MESSAGE:** The standard message (time, alarm type...) is printed at alarm activation, at alarm release, but operator message is not printed.

**MESSAGE ON:** Standard operator message is printed at alarm occurrence only.

**MESSAGE OFF:** Standard operator message is printed at alarm release only.

**MSG ON/OFF:** Standard operator message is printed at alarm activation and at alarm release.

**SEE ALSO:** **MESSAGE** in **MESSAGES** sub-matrix

**NOTE:** The selection of **NONE** does not prevent the printing of functional messages such as, messages of range, speed and group change, these are configurable by the **CHART DOC** sub-matrix **FUNCT MSG** parameters.  
In case of many **MESSAGES** the printing order can be changed.

---

## 4. CONFIGURATION

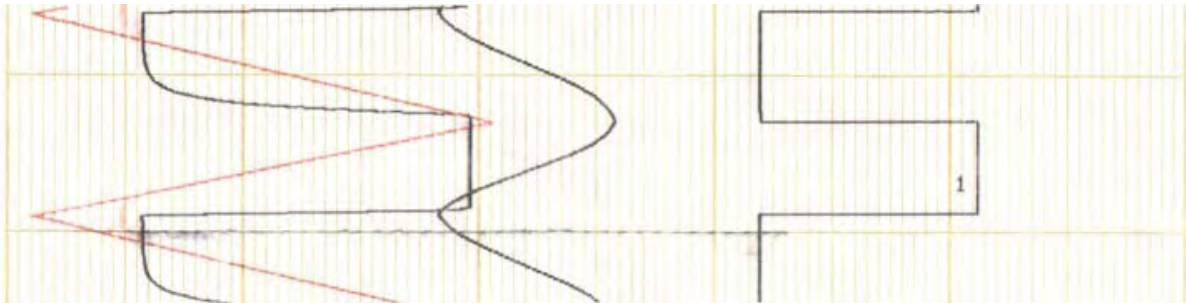

NONE

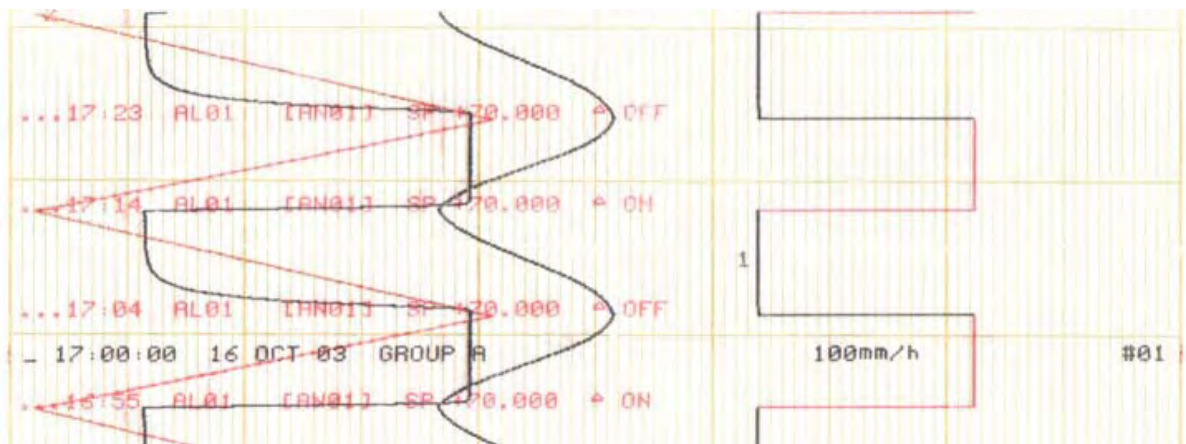

STD MESSAGE

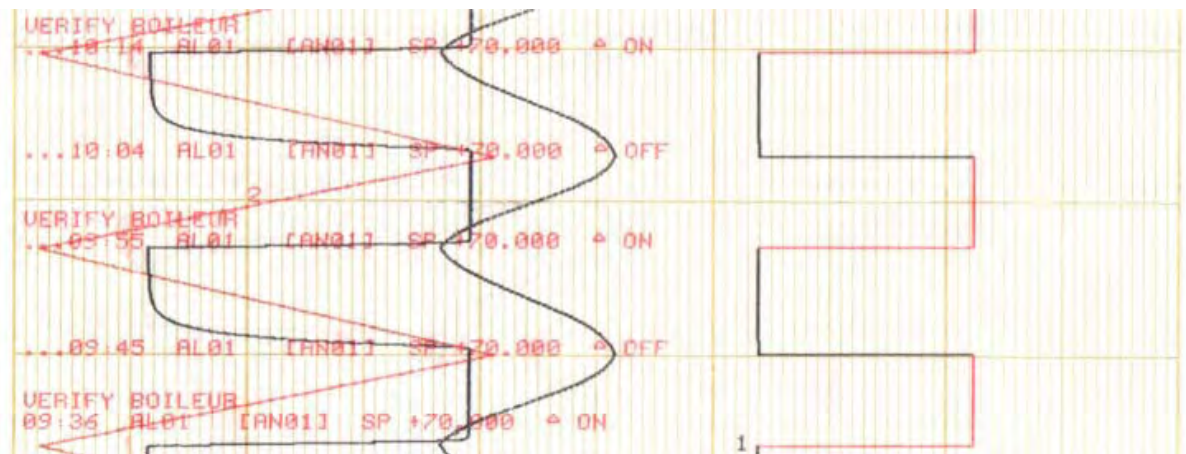

MESSAGE ON

## 4. CONFIGURATION

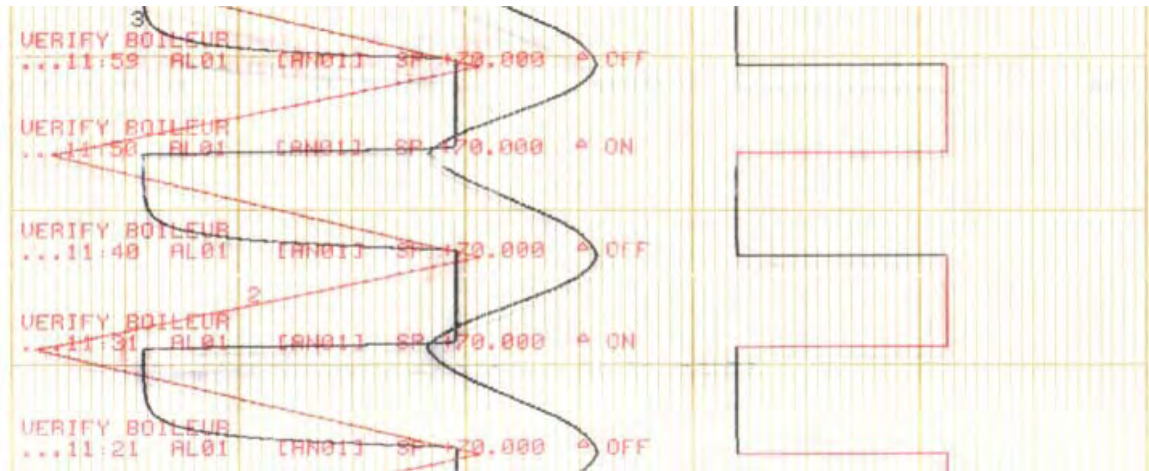

MESSAGE OFF

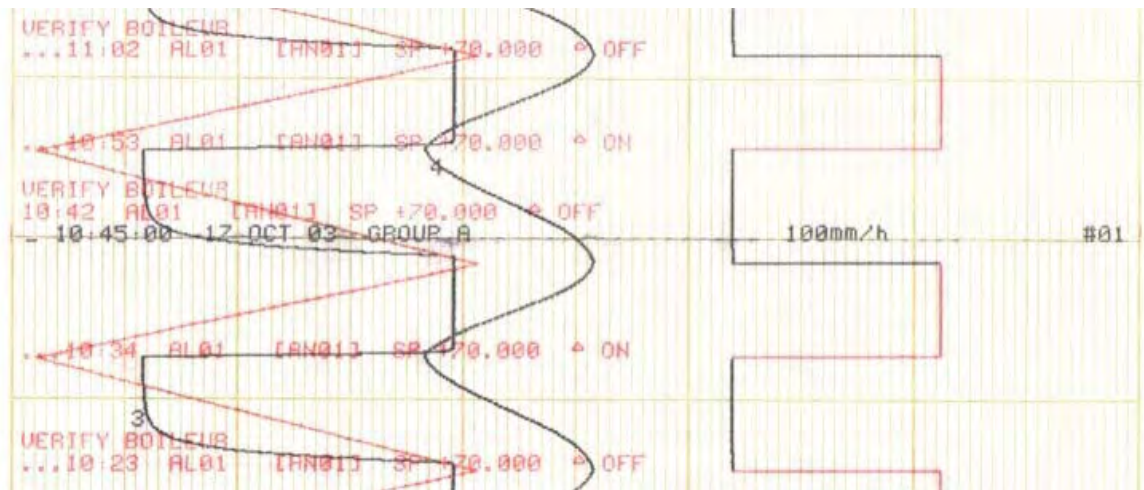

MESSAGE ON/OFF

## 4. CONFIGURATION

---

*SUB-MATRIX*

*PARAMETER*

*CLASSIFICATION*

---

**ALARM**

**RED IN AL**



**DEFINITION:** Specifies if the trend trace will be printed in red during alarm condition.

**HOW TO MODIFY IT:** Choose a new selection.

**POSSIBLE CHOICES:** NO  
YES

**SEE ALSO:** If **RED IN AL** is selected, do not configure the trace color in red as normal printing.

---

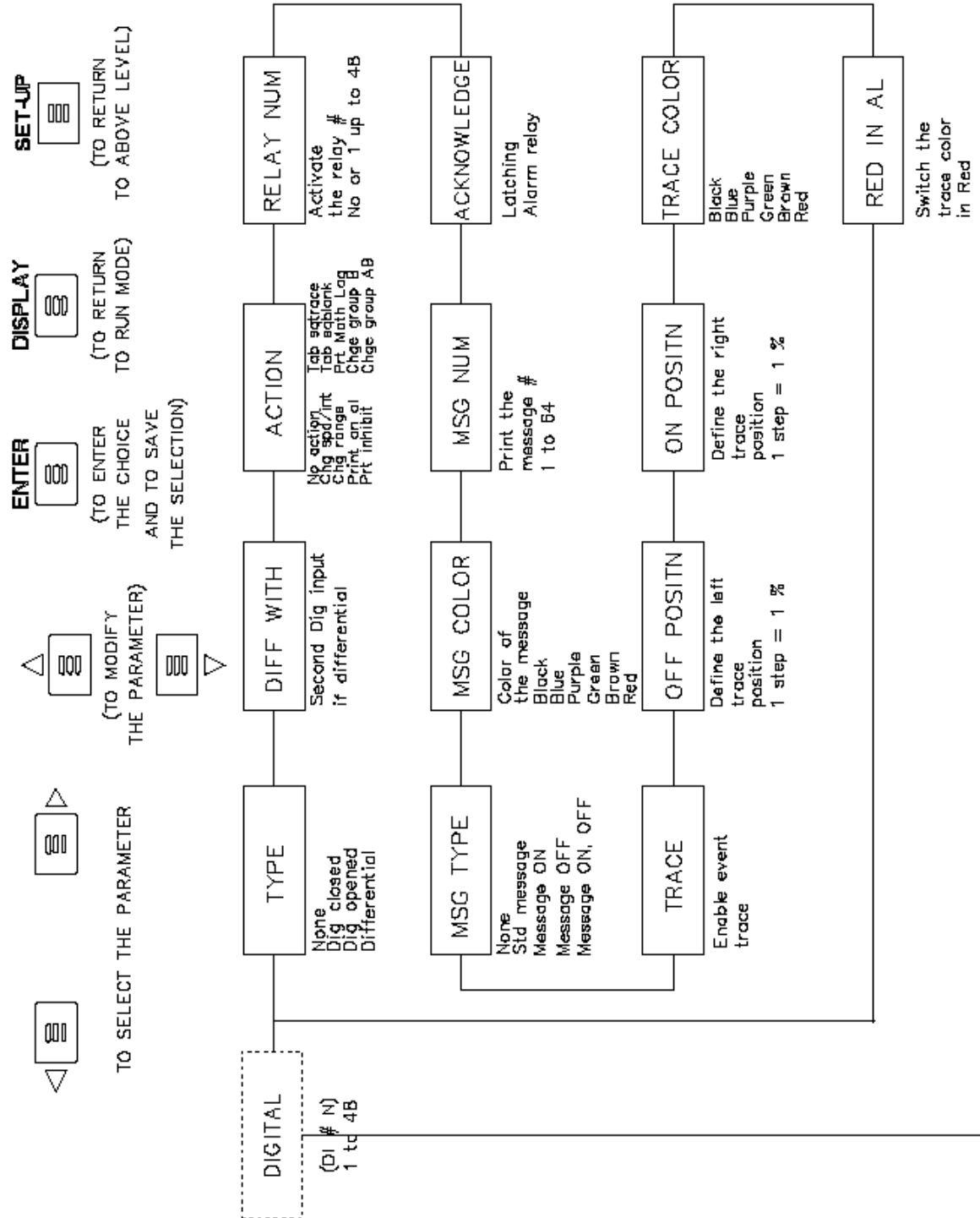

### SUB – MATRIX

# DIGITAL

Configuration of digital input parameters with their actions

### PARAMETERS

<b>TYPE</b>	page 4-48
<b>DIFF WITH</b>	page 4-49
<b>ACTION</b>	page 4-50
<b>RELAY NUM</b>	page 4-51
<b>ACKNOWLEDGE</b>	page 4-51
<b>MSG NUM</b>	page 4-52
<b>MSG COLOR</b>	page 4-52
<b>MSG TYPE</b>	page 4-53
<b>TRACE</b>	page 4-53
<b>OFF POSITN</b>	page 4-54
<b>ON POSITN</b>	page 4-54
<b>TRACE COLOR</b>	page 4-55
<b>RED IN AL</b>	page 4-55



## 4. CONFIGURATION

---

SUB-MATRIX	PARAMETER	CLASSIFICATION
<b>DIGITAL</b>	<b>TYPE</b>	◆◆□□

---

**DEFINITION:** Type of digital input.

**HOW TO MODIFY IT:** Select a new digital input type.

**POSSIBLE CHOICES:** **NONE:** Select "none" for no action on digital inputs and no standard message.

**DIG CLOSED:** Action to occur when digital input is ON (contact closed).

**DIG OPENED:** Action to occur when digital input is OFF (contact opened).

**DIFFERENTIAL:** Action to occur when digital input changes to a different state from another specified digital input. (Function XOR)

**SEE ALSO:** **DIFF WITH** for **DIFFERENTIAL** in this sub-matrix.

**EXAMPLE:**

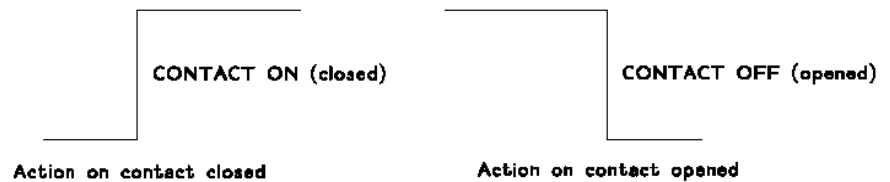

## 4. CONFIGURATION

---

SUB-MATRIX

PARAMETER

CLASSIFICATION

**DIGITAL**

**DIFF WITH**



**DEFINITION:** Second digital input to be used if the first digital input type is differential.

**HOW TO MODIFY IT:** Select a new value.

**POSSIBLE CHOICES:** DIGITAL # i (i = 1 ... 48)

**NOTE:** For the difference between 2 channels, it is recommended to take first the highest channel reference and subtract from the other channel.  
*Example:*  
You want to make a difference between channels 7 and 12:  
make ch12 minus ch7.

---

## 4. CONFIGURATION

---

<i>SUB-MATRIX</i>	<i>PARAMETER</i>	<i>CLASSIFICATION</i>
<b>DIGITAL</b>	<b>ACTION</b>	◆◆□□

---

**DEFINITION:** Action on printer in case of digital input change.

**HOW TO MODIFY IT:** Select a new action.

**POSSIBLE CHOICES:**

- NO ACTION:** No effect on printing.
- CHG SPD/INT:** Change chart speed/print interval.
- CHG RANGE:** Change to range 2 if **RANGE USED** = with R1 and to range 1 if **RANGE USED** = with R2
- PRINT ON AL:** Print the channel in alarm condition.
- PRT INHIBIT:** Stop all printing without data memorization.
- TAB SQTRACE:** Print one tabular snapshot of values superposed on traces.
- TAB SQBLANK:** Print one tabular snapshot of values on blank paper.
- PRT MATH LOG:** Print one tabular snapshot of maths results.
- CHG GROUP B:**  
CHG GROUP A to B: Print groups # i of channels defined in chart sub-matrix  
When the alarm turns ON, the group B is printed.  
When the alarm turns OFF, the group A is printed.
- CHG GROUP AB:**  
CHG GROUP A to A + B: Print groups # i of channels defined in chart sub-matrix.  
When the alarm turns ON, groups A and B are printed.  
When the alarm turns OFF, the group A is printed.

**SEE ALSO:** **RANGE USED** in **CHART** sub-matrix for **PRINT ON AL** and **CHG GROUP GROUP DEF** in **CHART** sub-matrix for **CHG GROUP**

**WARNING:** This **ACTION** parameter is taken into account only if **NORMAL** is selected for the **SELECTION** parameter of the **DIGITAL** sub-matrix.

---

## 4. CONFIGURATION

SUB-MATRIX	PARAMETER	CLASSIFICATION
DIGITAL	RELAY NUM	◆◆□□

**DEFINITION:** Selection of the relay activated with digital input.

**HOW TO MODIFY IT:** Select a new relay number

**POSSIBLE CHOICES:** NO RELAY  
RELAY # i (i = 1 ... 48)

SUB-MATRIX	PARAMETER	CLASSIFICATION
DIGITAL	ACKNOWLEDGE	◆◆□□

**DEFINITION:** To acknowledge all alarm latching relay outputs.

**POSSIBLE CHOICES:** **ENABLE:** Requires alarm acknowledgment to release all alarm relays.  
**DISABLE:** Normal alarm relay operation (no latching relay).

**EXAMPLE:**

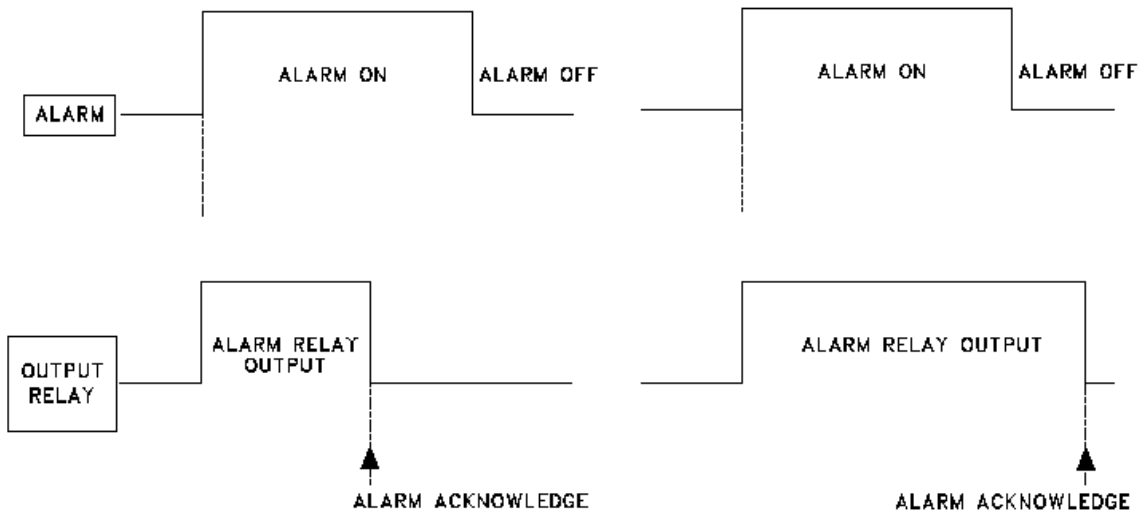

### NOTICE

If **ACKNOWLEDGE** is **ENABLE**, the parameter **ACK KEY** must also be enabled in sub-matrix **MMI**.

## 4. CONFIGURATION

---

<i>SUB-MATRIX</i>	<i>PARAMETER</i>	<i>CLASSIFICATION</i>
<b>DIGITAL</b>	<b>MSG NUM</b>	◆□□

---

**DEFINITION:** Selection of the message to be printed.

**HOW TO MODIFY IT:** Select a new message number.

**POSSIBLE CHOICES:** MESSAGE # i (i = 1 ... 64)

**SEE ALSO:** MSG TYPE in this sub-matrix  
Without message # only the standard message is printed.

---

<i>SUB-MATRIX</i>	<i>PARAMETER</i>	<i>CLASSIFICATION</i>
<b>DIGITAL</b>	<b>MSG COLOR</b>	◆□□

---

**DEFINITION:** Color of the message.

**HOW TO MODIFY IT:** Select a new color.

**POSSIBLE CHOICES:** BLACK  
BLUE  
PURPLE  
GREEN  
BROWN  
RED

---

## 4. CONFIGURATION

---

<i>SUB-MATRIX</i>	<i>PARAMETER</i>	<i>CLASSIFICATION</i>
<b>DIGITAL</b>	<b>MSG TYPE</b>	◆□□

---

- DEFINITION:** Defines when the digital message is printed.
- HOW TO MODIFY IT:** Select a new **MSG TYPE**.
- POSSIBLE CHOICES:** **NONE:** The standard message (date, time, alarm type ...), and the operator message are not printed.
- STD MESSAGE:** The standard message (date, time, alarm type...) is printed at alarm activation, at alarm release, but operator message is not printed.
- MESSAGE ON:** Standard operator message is printed when the digital contact is closed.
- MESSAGE OFF:** Standard operator message is printed when the digital contact is opened.
- MSG ON/OFF:** Standard operator message is printed when the digital contact is closed and opened.
- SEE ALSO:** **MESSAGE** in **MESSAGES** sub-matrix
- WARNING:** The selection of **NONE** does not prevent the printing of functional messages such as, messages of range, speed and group change, these are configurable by the **CHART DOC** sub-matrix **FUNCT MSG** parameters.  
In case of many **MESSAGES** the printing order can be changed.

---

<i>SUB-MATRIX</i>	<i>PARAMETER</i>	<i>CLASSIFICATION</i>
<b>DIGITAL</b>	<b>TRACE</b>	◆◆□□

---

- DEFINITION:** Enable/disable the digital trace.
- POSSIBLE CHOICES:** **ENABLE**
- DISABLE**

## 4. CONFIGURATION

SUB-MATRIX	PARAMETER	CLASSIFICATION
DIGITAL	OFF POSITN	◆◆□□

**DEFINITION:** Defines the trace position (DI = OFF) on the chart. (in %)  
One increment = 1%.

**EXAMPLE:** See example on next page.

SUB-MATRIX	PARAMETER	CLASSIFICATION
DIGITAL	ON POSITN	◆◆□□

**DEFINITION:** Defines the trace position (DI = OFF) on the chart. (in %)  
One increment = 1%.

**EXAMPLE:**

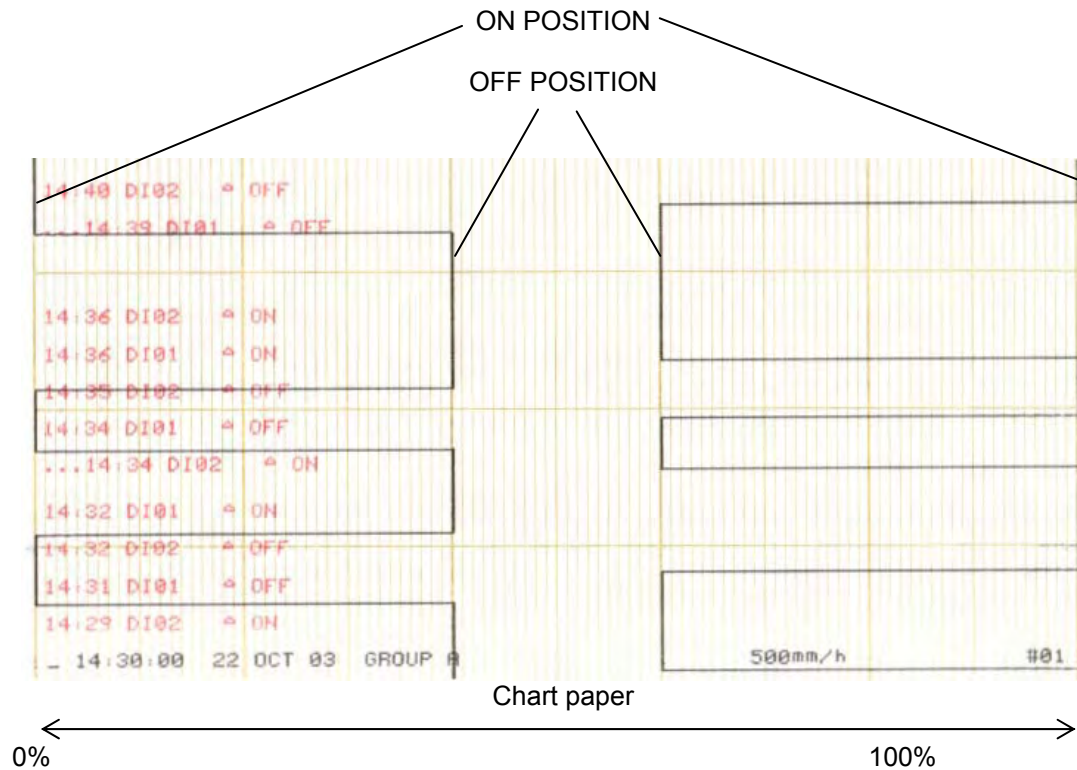

## 4. CONFIGURATION

---

*SUB-MATRIX*

*PARAMETER*

*CLASSIFICATION*

**DIGITAL**

**TRACE COLOR**



**DEFINITION:** Defines the color of the digital trace.

**HOW TO MODIFY IT:** Select a new color.

**POSSIBLE CHOICES:** BLACK  
BLUE  
PURPLE  
GREEN  
BROWN  
RED

---

*SUB-MATRIX*

*PARAMETER*

*CLASSIFICATION*

**DIGITAL**

**RED IN AL**



**DEFINITION:** Specifies if the digital input trace will be printed in red with digital action.

**HOW TO MODIFY IT:** Select a new value.

**POSSIBLE CHOICES:** NO  
YES

**NOTICE** If **RED IN AL** is selected: do not configure the trace in red as normal printing.



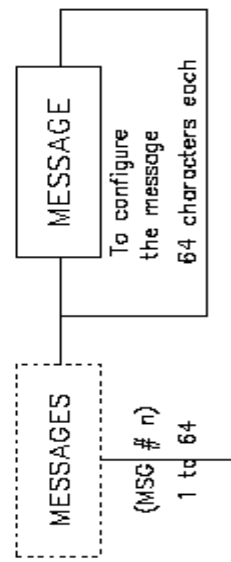
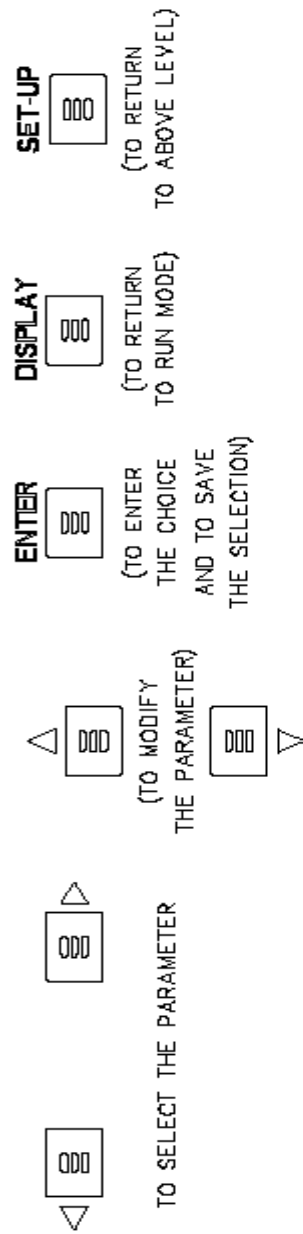

**SUB – MATRIX**

# **MESSAGES**

Configuration of customer messages

**PARAMETER**

## **MESSAGE**

page 4-58

## 4. CONFIGURATION

---

<i>SUB-MATRIX</i>	<i>PARAMETER</i>	<i>CLASSIFICATION</i>
<b>MESSAGES</b>	<b>MESSAGE</b>	◆□

---

**DEFINITION:** To configure the messages (1 to 64).

**HOW TO MODIFY IT:** Enter text digit by digit with the ▲ and ▼ keys

**POSSIBLE CHOICES:** 64 alpha numerical characters

**NOTICE** If the message is larger than 64 characters, the last digit takes the place of the first one, giving a wrong message

**NOTE:** Configuration of message 1 when used with the tabular printout will create a header message (This is for software version AM or later). The frequency of the message being printed is determined via the chart documentation print interval.

---

## 4. CONFIGURATION

---

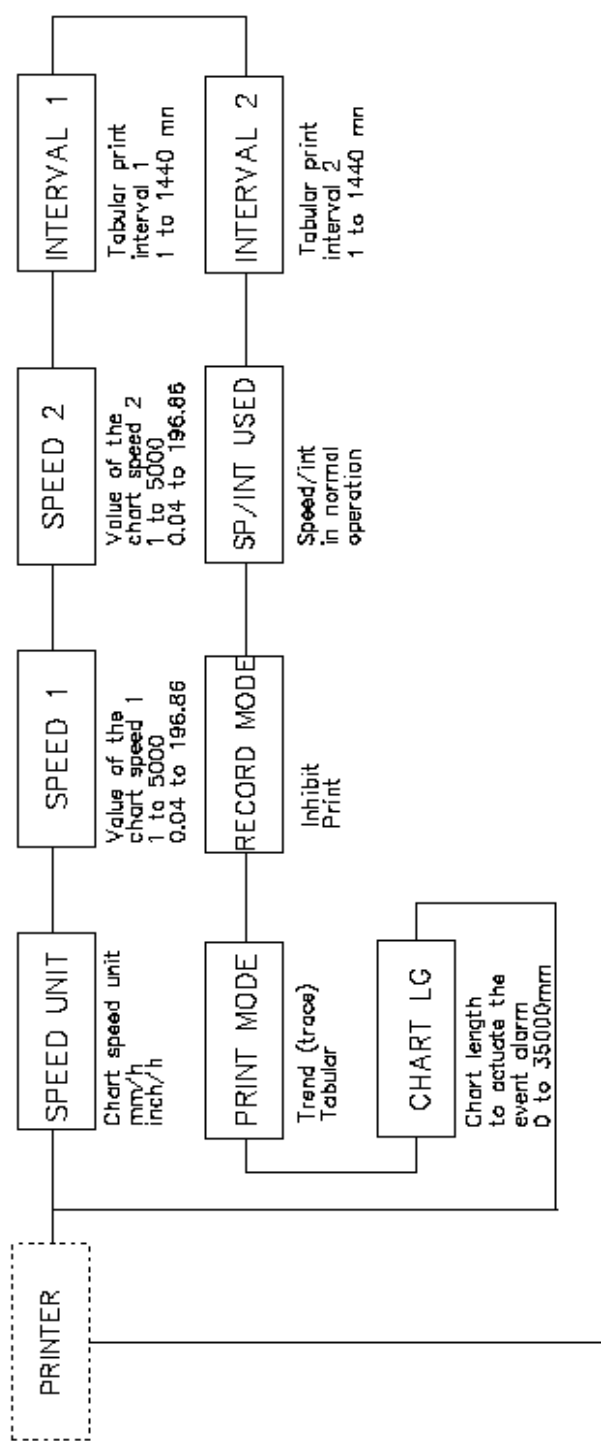
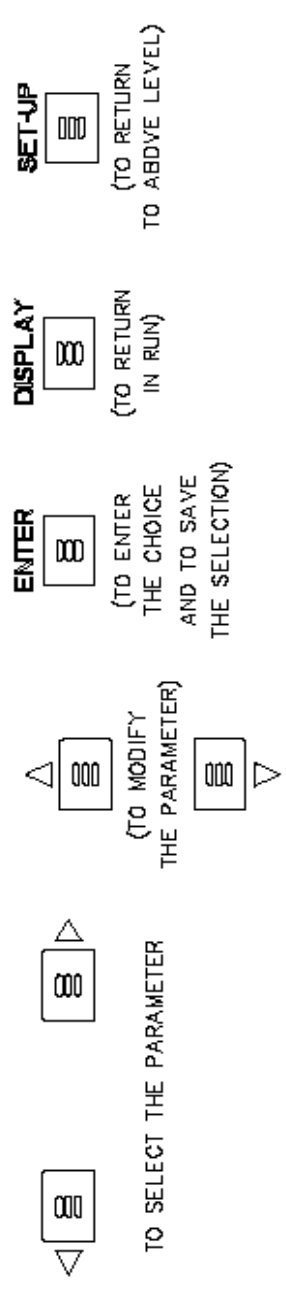

### SUB – MATRIX

# PRINTER

Configuration of the printer operation.

### PARAMETERS

**SPEED UNIT** page 4-61

**SPEED 1** page 4-62

**SPEED 2** page 4-63

**INTERVAL 1** page 4-64

**INTERVAL 2** page 4-64

**SP/INT USED** page 4-65

**RECORD MODE** page 4-65

**PRINT MODE** page 4-66

**CHART LG** page 4-67

## 4. CONFIGURATION

---

<i>SUB-MATRIX</i>	<i>PARAMETER</i>	<i>CLASSIFICATION</i>
<b>PRINTER</b>	<b>SPEED UNIT</b>	◆◆□

---

**DEFINITION:** Speed unit

**HOW TO MODIFY IT:** Select a new value.

**POSSIBLE CHOICES:** UNIT = mm/h  
or  
UNIT = inch/h

**NOTE:** When the unit is switched from mm/h to inch/h or reverse the chart speed 1 and 2 are converted to the nearest value.

---

## 4. CONFIGURATION

SUB-MATRIX	PARAMETER	CLASSIFICATION
PRINTER	<b>SPEED 1</b>	◆ □

**DEFINITION:** Value of speed 1 when PRINT MODE is TREND.

**HOW TO MODIFY IT:** Enter a numeric value based on speed unit selected.

**POSSIBLE CHOICES:** With mm/h unit:  
[1 ... 5000]  
or  
With inch/h unit:  
[0.04 ... 196.86]

Refer to **SPEED UNIT** to know the speed unit in use.

### NOTICE

The following elements may affect the printing performances:

- A fast chart speed.
- A large span printing
- Color arrangements printing

(See chart below for typical worst case)

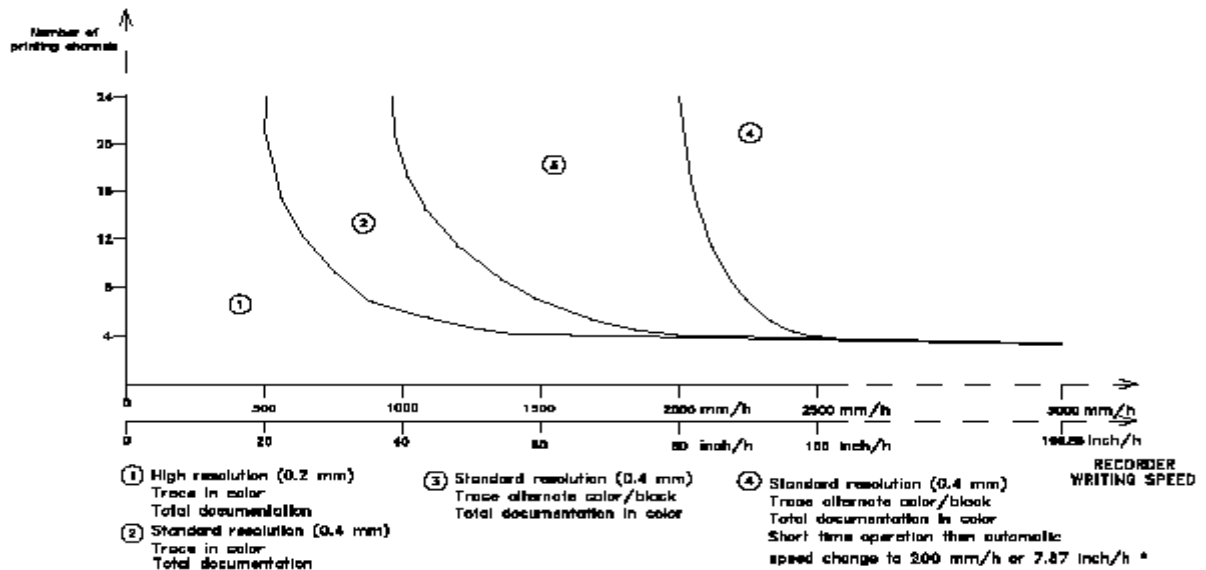

\* The return to the configured speed can be done by executing a PRT INHIBIT or by switching the recorder off and on or by changing the configuration mode, see page 4-2.

## 4. CONFIGURATION

SUB-MATRIX	PARAMETER	CLASSIFICATION
PRINTER	<b>SPEED 2</b>	◆ □

- DEFINITION:** Value of speed 2.
- HOW TO MODIFY IT:** Enter a numeric value based on speed unit selected.
- POSSIBLE CHOICES:** With mm/h unit:  
[1 ... 5000]  
or  
With inch/h unit:  
[0.04 ... 196.86]
- Refer to **SPEED UNIT** to know the speed unit in use.

### NOTICE

The following elements may affect the printing performances:

- A fast chart speed.
- A large span printing
- Color arrangements printing

(See chart below for typical worst case)

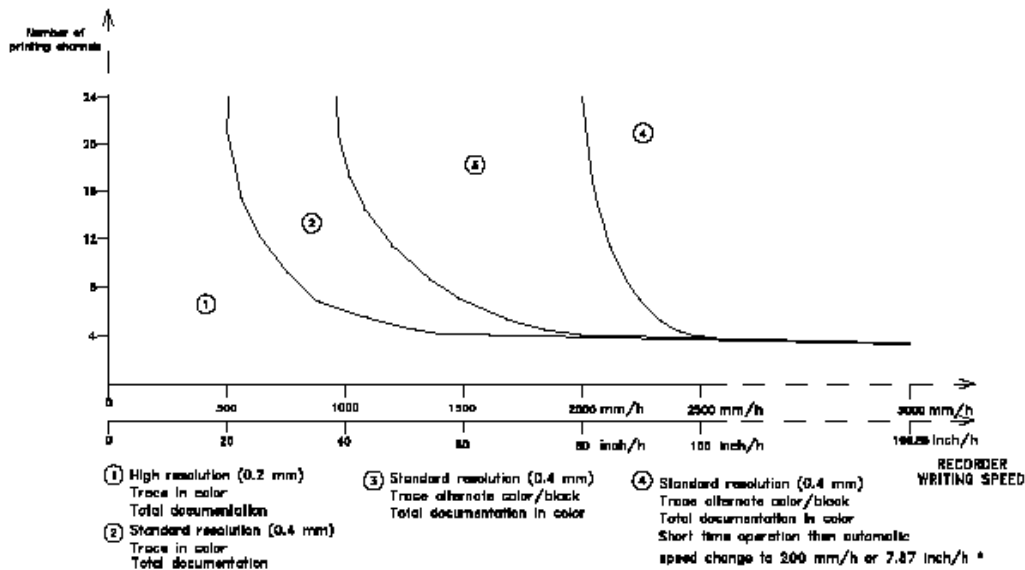

The return to the configured speed can be done by executing a PRT INHIBIT or by switching the recorder off and on or by changing the configuration mode, see page 4-2.



**4. CONFIGURATION**

---

<i>SUB-MATRIX</i>	<i>PARAMETER</i>	<i>CLASSIFICATION</i>
<b>PRINTER</b>	<b>INTERVAL 1</b>	◆□

---

**DEFINITION:** Tab 1 prints interval. (In minutes)

**HOW TO MODIFY IT:** Select a new time.

**POSSIBLE CHOICES:** to 1440 minutes

**SEE ALSO:** PRINT MODE in this sub-matrix.

---

<i>SUB-MATRIX</i>	<i>PARAMETER</i>	<i>CLASSIFICATION</i>
<b>PRINTER</b>	<b>INTERVAL 2</b>	◆□

---

**DEFINITION:** Tab 2 prints interval. (In minutes)

**HOW TO MODIFY IT:** Select a new time.

**POSSIBLE CHOICES:** to 1440 minutes

**SEE ALSO:** PRINT MODE in this sub-matrix.

---

## 4. CONFIGURATION

---

SUB-MATRIX

PARAMETER

CLASSIFICATION

---

**PRINTER**

**SP / INT USED**



---

**DEFINITION:** Defines speed in use in alarm off.

**HOW TO MODIFY IT:** Select a new speed.

**POSSIBLE CHOICES:** **SPEED 1**

**SPEED 2**

**NOTE:** If printing mode (**PRINT MODE**) is **TABULAR**, **SPEED 1**, **SPEED 2** is understood to be **INTERVAL 1**, **INTERVAL 2**.

---

SUB-MATRIX

PARAMETER

CLASSIFICATION

---

**PRINTER**

**RECORD MODE**



---

**DEFINITION:** Recording mode allows you to print normally or to stop the printer.

**HOW TO MODIFY IT:** Select a new value.

**POSSIBLE CHOICES:** **INHIBIT**

**PRINT**

**NOTICE** The selection of **INHIBIT** takes priority over **PRINT INHIBIT** requested on **ALARM** or with **BASIC ACTIONS**.

---

## 4. CONFIGURATION

SUB-MATRIX	PARAMETER	CLASSIFICATION
<b>PRINTER</b>	<b>PRINT MODE</b>	◆◆□□

**DEFINITION:** Under this heading you must choose whether recording will be in **TREND** mode or **TABULAR** mode.

**HOW TO MODIFY IT:** Select a new printing mode.

**POSSIBLE CHOICES:** **TREND:** All channels recorded as trends.  
**TABULAR:** All channels recorded in tabular format.  
**TREND WITH HEADING:** All channels recorded as trends and in tabular form.

**NOTE:** In tabular mode, you define the time interval between 2 print-outs (chart speed being defined in trend mode).  
 In trend with heading mode, the header needs to be specified in message number one. The frequency that header info appears on the tabular chart can be adjusted by chart-doc print interval.

**EXAMPLE:**

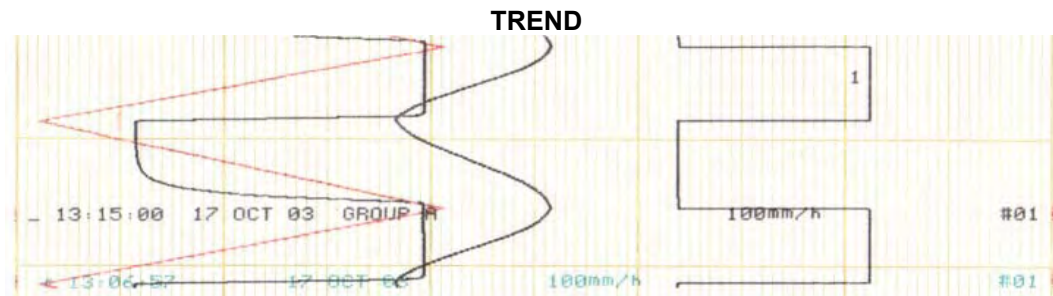

**TABULAR**

CH03 30.4 M/3 DEBIT	CH04 58.3 L/H FLUX
CH01 63.9 DEG TEMP	CH02 27.2 BAR PRESSION
13-14 22OCT03	
CH03 37.7 M/3 DEBIT	CH04 60.5 L/H FLUX
CH01 63.9 DEG TEMP	CH02 34.7 BAR PRESSION
13-12 22OCT03	
CH03 51.4 M/3 DEBIT	CH04 61.1 L/H FLUX
CH01 82.3 DEG TEMP	CH02 39.3 BAR PRESSION
13-10 22OCT03	
CH03 51.4 M/3 DEBIT	CH04 59.5 L/H FLUX
CH01 82.3 DEG TEMP	CH02 31.2 BAR PRESSION
13-08 22OCT03	

**TABULAR WITH HEADING**

CH07 0.000 VOLTS COLD CAT	CH05 -402 DEG F CONTROL	CH06 0.000 VOLTS PIRANI
CH04 -.... DEG F WORK TC	CH02 -.... DEG F WORK TC	CH03 -.... DEG F WORK TC
CH01 -.... DEG F WORK TC		
HEADER MESSAGE		
11:54 03JAN04		
CH07 0.000 VOLTS COLD CAT	CH05 -402 DEG F CONTROL	CH06 0.000 VOLTS PIRANI
CH04 -.... DEG F WORK TC	CH02 -.... DEG F WORK TC	CH03 -.... DEG F WORK TC
CH01 -.... DEG F WORK TC		
HEADER MESSAGE		
11:53 03JAN04		

## 4. CONFIGURATION

---

SUB-MATRIX

PARAMETER

CLASSIFICATION

---

**PRINTER**

**CHART LG**



**DEFINITION:**

Specifies the chart length of the chart roll or fanfold which actuates the event alarm.

This is used with the recorder **EVENTS** to signal when the chart paper has reached the pre-configured chart length.

**HOW TO MODIFY IT:**

Enter length value chart.

**POSSIBLE CHOICES:**

[0...35000] mm

[0...1378] inch

Refer to **SPEED UNIT** in this matrix to know the unit in use. (See page 4-61)

**SEE ALSO:**

**EVENT TYPE** in **EVENTS** sub-matrix. (See page 4-85)

**NOTICE**

The maximum length value of chart paper is 35 m. (115 ft.)

---

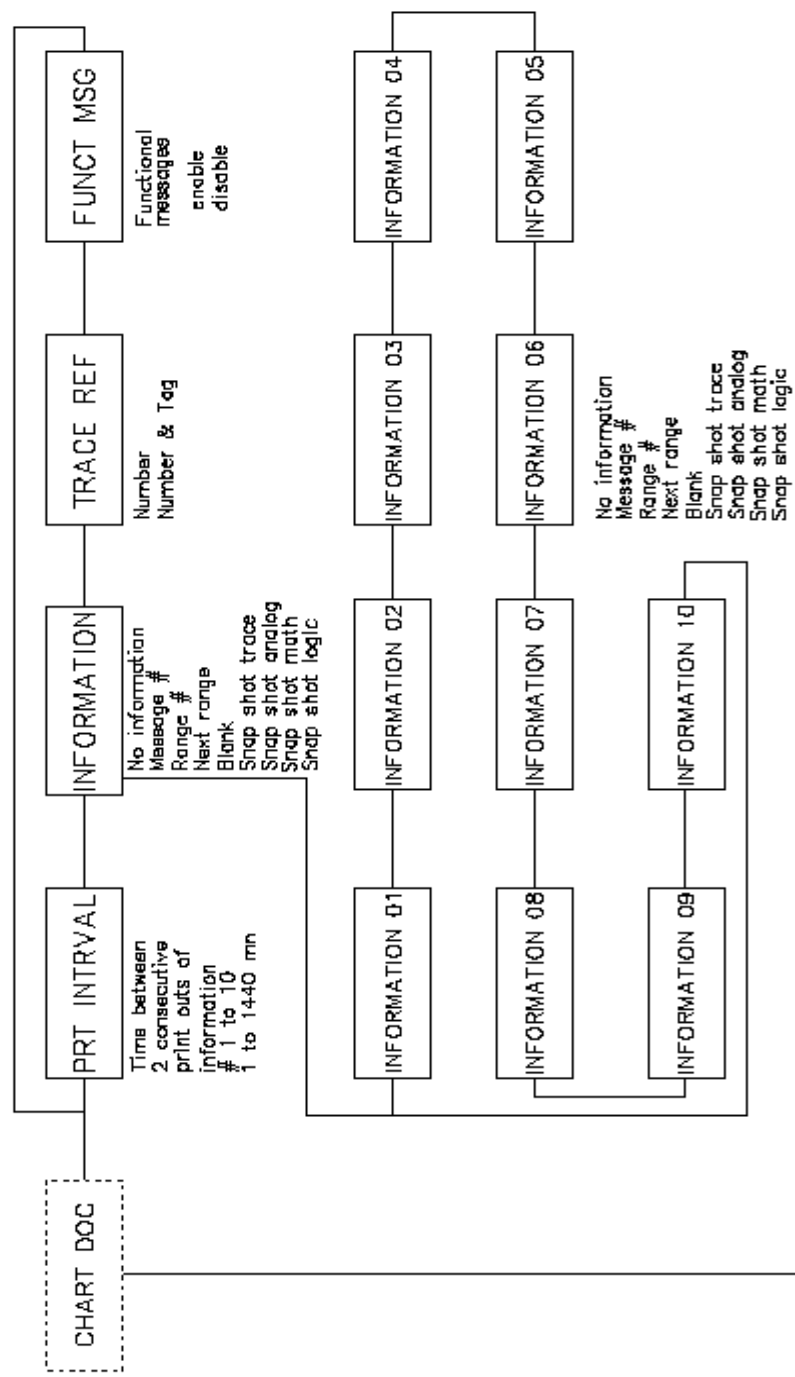
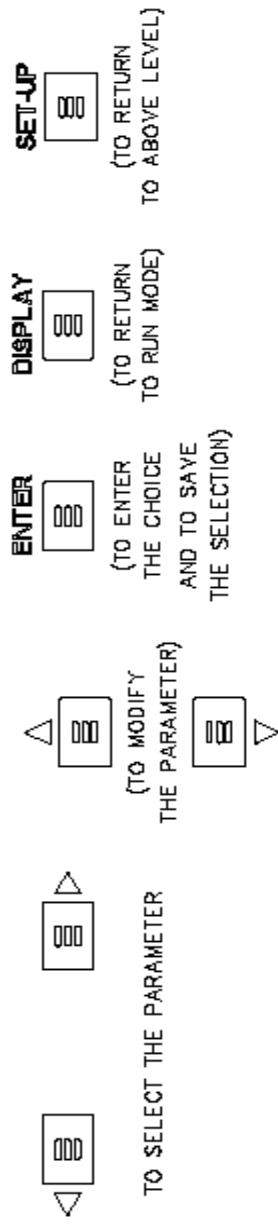

### SUB – MATRIX

# CHART DOC

Configuration of periodic chart information

### PARAMETERS

<b>PRT INTRVAL</b>	page 4-70
<b>INFORMATION 01</b>	page 4-71
<b>INFORMATION 02</b>	page 4-71
<b>INFORMATION 03</b>	page 4-71
<b>INFORMATION 04</b>	page 4-71
<b>INFORMATION 05</b>	page 471
<b>INFORMATION 06</b>	page 4-71
<b>INFORMATION 07</b>	page 4-71
<b>INFORMATION 08</b>	page 4-71
<b>INFORMATION 09</b>	page 4-71
<b>INFORMATION 10</b>	page 4-71
<b>TRACE REF</b>	page 4-74
<b>FUNCT MSG</b>	page 4-75

## 4. CONFIGURATION

---

<i>SUB-MATRIX</i>	<i>PARAMETER</i>	<i>CLASSIFICATION</i>
<b>CHART DOC</b>	<b>PRT INTERVAL</b>	◆□

---

**DEFINITION:** Separation between two consecutive information print outs # 1 to 10 printed on the chart.

**HOW TO MODIFY IT:** Select a new printing interval.

**POSSIBLE CHOICES:** [1 ... 1440] mn  
mn = minute

### **NOTICE**

Printing **CHART DOC** is printed over the **TRACE**.  
When **SPEED** is too slow and **PRT INTRVAL** is too short, the **PRT INTRVAL** is automatically adapted to have messages printed just one after the other.

Select the chart speed to be able to print all documentation during the selected time

---

## 4. CONFIGURATION

SUB-MATRIX

PARAMETER

CLASSIFICATION

CHART DOC

**INFORMATION 01, ...10**



**DEFINITION:** Next information is printed at a distance which depends on **PRT INTRVAL** value and print speed.

**HOW TO MODIFY IT:** Select a new value.

**POSSIBLE CHOICES:** **NO INFORMATION:** Jump to next information  
**MESSAGE # i (i = 1 ... 64)**  
**RANGE # i and chart certification \*** : Specific chart number  
**NEXT RANGE**  
**BLANK:** No printed information  
**SNAP SHOT TRACE:** Trace snapshot of selected printing traces  
**SNAP SHOT ANALOG**  
**SNAP SHOT MATH:** Table of maths results  
**SNAP SHOT LOGIC**

\* If "**SUB DIV**" in the **CHART** sub-matrix is different from **NO DIVISION**, 2 lines are printed.

**EXAMPLES:**

**RANGE # i and chart certification.** To jump to a specific range #.  
 Ranges are printed with the same color as the corresponding traces.

(NO DIVISIONS)

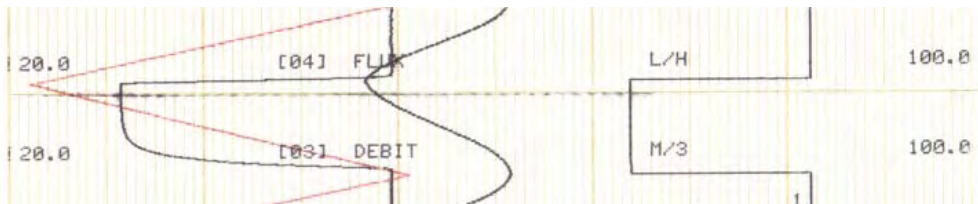

(SUB DIVISIONS)

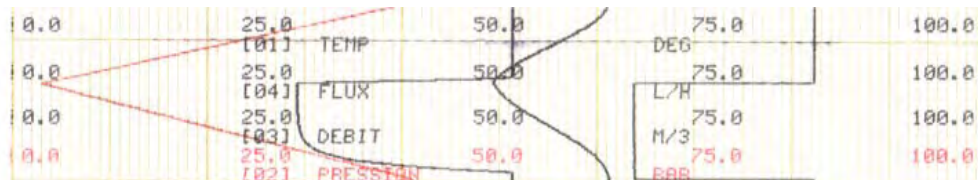



## 4. CONFIGURATION

SUB-MATRIX	PARAMETER	CLASSIFICATION
CHART DOC	INFORMATION 01, ...10	◆ □

**EXAMPLE:** **NEXT RANGE** prints the next range # with chart certification

(NO DIVISIONS)

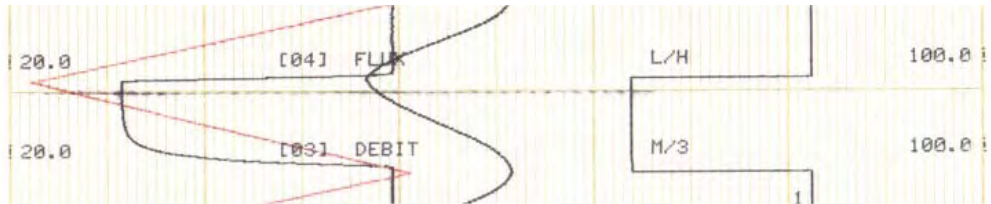

(SUB DIVISIONS)

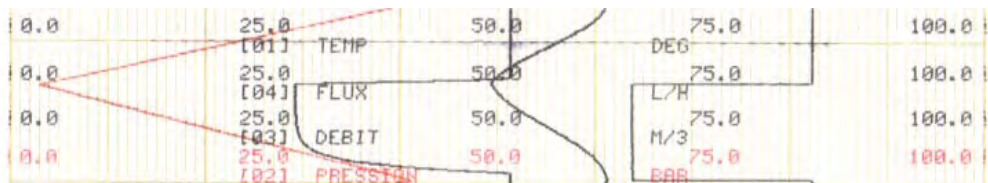

SNAP SHOT



Messages are printed in sequenced colors in order to improve the life expectancy of the printing ribbon.

## 4. CONFIGURATION

### SNAP SHOT ANALOG

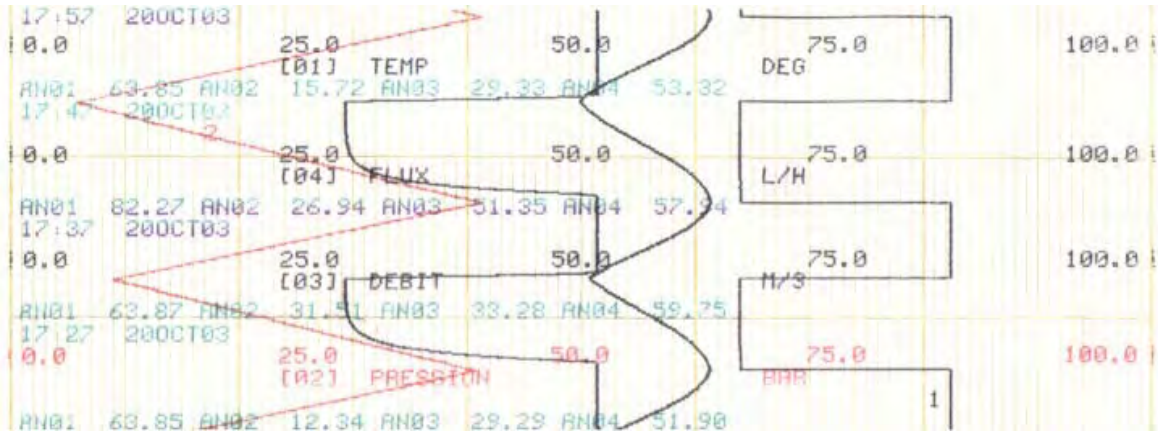

### SNAP SHOT MATH

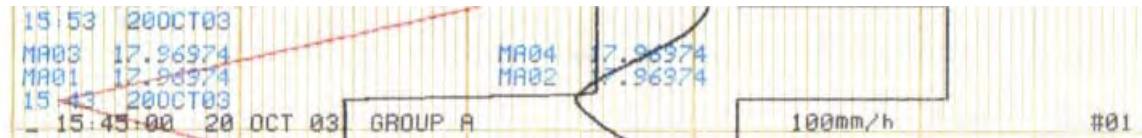

### SNAP SHOT LOGIC



**CAUTION:**

**DATE, TIME, SPEED, ID: Periodic printing not configurable.**

## 4. CONFIGURATION

SUB-MATRIX	PARAMETER	CLASSIFICATION
CHART DOC	TRACE REF	◆ □

**DEFINITION:** Specifies whether a number or number plus tag name is printed along side the trace to identify the channel.

**POSSIBLE CHOICES:** **NUMBER:** Channel number only

**NUMBER & TAG:** Channel number & tag name

**EXAMPLES:**

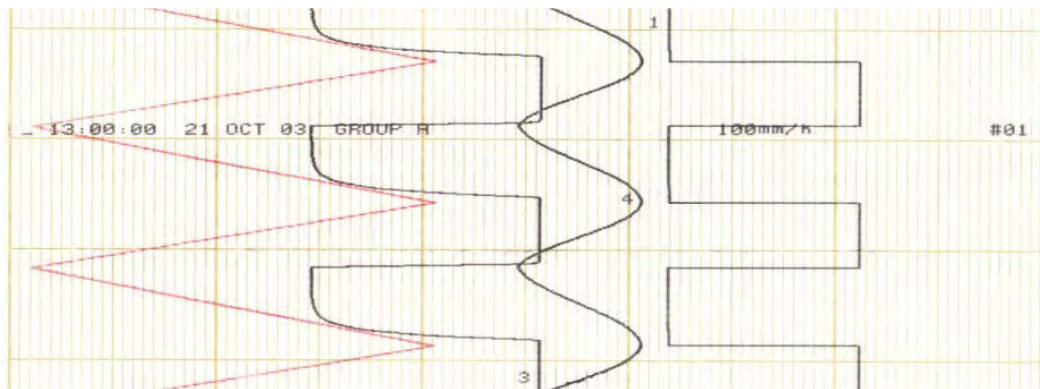

**Number only**

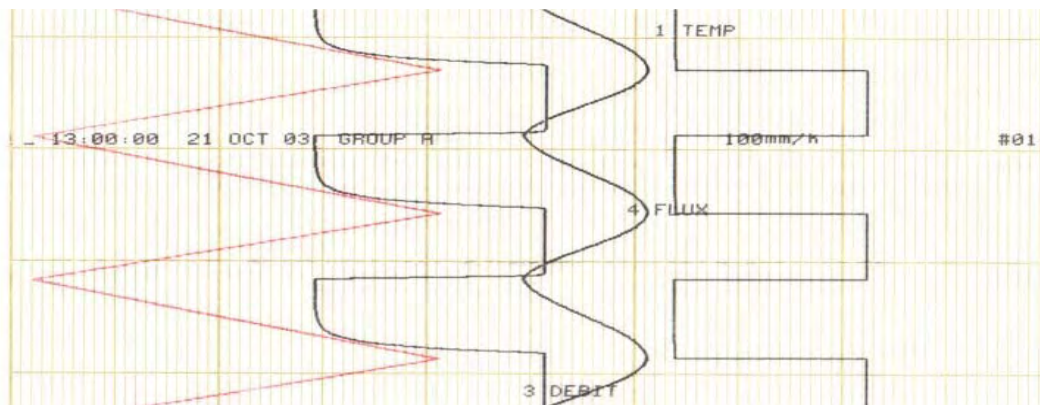

**Number + Tag**

**NOTE:** The trace reference is printed periodically and sequentially

## 4. CONFIGURATION

---

*SUB-MATRIX*

*PARAMETER*

*CLASSIFICATION*

---

**CHART DOC**

**FUNCT MSG**



**DEFINITION:**

Change range, change speed, change group and print inhibit messages are the functional messages of the recorder.

The **FUNCT MSG** parameter allows the customer to select whether to print these messages on the paper.

**POSSIBLE CHOICES:** **ENABLE**

**DISABLE**

---

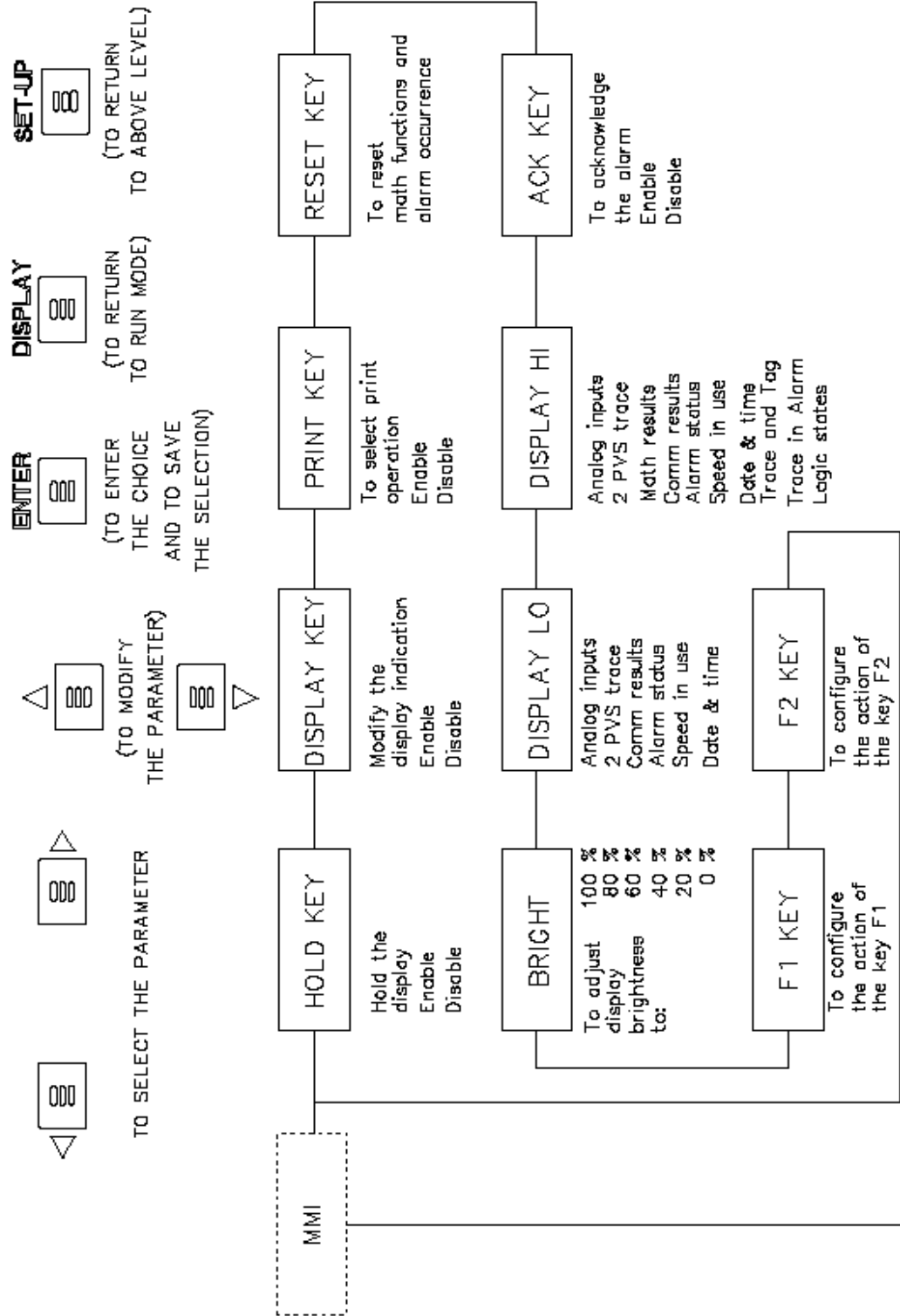

### SUB – MATRIX

## MMI

Configuration of key actions and display of operations

### PARAMETERS

**HOLD KEY** page 4-78

**DISPLAY KEY** page 4-78

**PRINT KEY** page 4-79

**RESET KEY** page 4-79

**ACK KEY** page 4-80

**DISPLAY HI** page 4-80

**DISPLAY LO** page 4-81

**BRIGHT** page 4-81

**F1 KEY** page 4-82

**F2 KEY** page 4-82

See page 3-1 for diagram of key location.

## 4. CONFIGURATION

<i>SUB-MATRIX</i>	<i>PARAMETER</i>	<i>CLASSIFICATION</i>
<b>MMI</b>	<b>HOLD KEY</b>	◆□
<b>DEFINITION:</b>	To enable the Hold key so the operator can modify the display scanning from the keyboard and hold the upper display on a desired channel.	
<b>HOW TO MODIFY IT:</b>	Choose a new selection.	
<b>POSSIBLE CHOICES:</b>	<b>ENABLE</b> <b>DISABLE</b>	
<b>NOTE:</b>	The possible actions are: - Scan - Hold: Stops the scanning of the upper display on the current channel. Use the keys ▲ or ▼ to change the channel number shown on the upper display.	
<b>SEE ALSO:</b>	SECTION 3.5 " OPERATOR INITIATED ACTIONS"	

<i>SUB-MATRIX</i>	<i>PARAMETER</i>	<i>CLASSIFICATION</i>
<b>MMI</b>	<b>DISPLAY KEY</b>	◆□
<b>DEFINITION:</b>	To enable the display key so the operator can modify the display from the keyboard.	
<b>HOW TO MODIFY IT:</b>	Choose a new selection.	
<b>POSSIBLE CHOICES:</b>	<b>ENABLE</b> <b>DISABLE</b>	
<b>NOTE:</b>	This key gives access to the different configuration. For each display the possible indications are the same as the configuration of <b>DISPLAY HI</b> , <b>DISPLAY LO</b> Parameters.	
<b>SEE ALSO:</b>	SECTION 3.5 " OPERATOR INITIATED ACTIONS"	

## 4. CONFIGURATION

<i>SUB-MATRIX</i>	<i>PARAMETER</i>	<i>CLASSIFICATION</i>
<b>MMI</b>	<b>PRINT KEY</b>	◆□
<b>DEFINITION:</b>	To enable the printer key so the operator can modify the display from the keyboard.	
<b>HOW TO MODIFY IT:</b>	Choose a new selection.	
<b>POSSIBLE CHOICES:</b>	<b>ENABLE</b> <b>DISABLE</b>	
<b>NOTE:</b>	If <b>ENABLE</b> is selected, you may choose one or more of the following actions:  <b>INHIBIT</b> or <b>PRINTING</b> <b>RESET PAPER LENG</b> <b>SPEED/INT 2</b> or <b>SPEED/INT 1</b> <b>PRINT DATE&amp;TIME</b> <b>SNAP SHOT TRACE</b> <b>CHART ADVANCE</b> <b>CHG GROUP B</b> or <b>CHG GROUP A</b> <b>CHG GROUP A+B</b> or <b>CHG GROUP B</b> <b>SNAP SHOT LOGIC</b> <b>SNAP SHOT MATH</b> <b>START ARCHIVE</b> or <b>STOP ARCHIVE</b> <b>REMOVE PCMCIA</b>	
<b>SEE ALSO:</b>	SECTION 3.5 " OPERATOR INITIATED ACTIONS"	

<i>SUB-MATRIX</i>	<i>PARAMETER</i>	<i>CLASSIFICATION</i>
<b>MMI</b>	<b>RESET KEY</b>	◆□
<b>DEFINITION:</b>	To reset the maths functions or alarm occurrence.	
<b>HOW TO MODIFY IT:</b>	Choose a new selection.	
<b>POSSIBLE CHOICES:</b>	<b>ENABLE</b> <b>DISABLE</b>	
<b>NOTE:</b>	The possible actions are: - RESET MATH # - RESET ALL MATHS - RESET OCCURRENCE - RESET ALL OCCUR - RESET PCMCIA	



## 4. CONFIGURATION

SUB-MATRIX	PARAMETER	CLASSIFICATION
<b>MMI</b>	<b>ACK KEY</b>	◆ □
<b>DEFINITION:</b>	To release ALL energized alarms that have <b>ACKNOWLEDGE</b> enabled in <b>ALARM</b> and <b>DIGITAL</b> sub-matrices.	
<b>HOW TO MODIFY IT:</b>	Choose a new selection.	
<b>POSSIBLE CHOICES:</b>	<b>ENABLE</b> <b>DISABLE</b>	
<b>NOTE:</b>	See sub-matrices: <b>ALARM, DIGITAL</b> in <b>ACK KEY</b> parameter.	

SUB-MATRIX	PARAMETER	CLASSIFICATION
<b>MMI</b>	<b>DISPLAY HI</b>	◆ □
<b>DEFINITION:</b>	Type of information displayed on the upper line of the display in the run mode at power on.	
<b>HOW TO MODIFY IT:</b>	Choose a new selection.	
<b>POSSIBLE CHOICES:</b>	<b>Displayed messages:</b>	<b>Explanation:</b>
	<b>ANALOG INPUTS</b>	: Display the analog inputs configured
	<b>2 PVS TRACE</b>	: 2 consecutive channel traces are displayed on the same display line
	<b>MATH RESULTS*</b>	: Display maths results
	<b>COMM RESULTS</b>	: Display communication channels
	<b>ALARM STATUS</b>	: Display alarm states
	<b>SPEED IN USE</b>	: Display the chart speed in use
	<b>DATE &amp; TIME</b>	: Display the date and time
	<b>TRACE &amp; TAG*</b>	: For all traces configured on the display # 1, display the tag name, and on the display # 2 the value, the unit and the alarm associated
	<b>TRACE IN ALARM*</b>	: Display the states of alarm associated for all traced channels
	<b>LOGIC STATES*</b>	: Display states
<b>NOTE:</b>	*This parameter uses both the upper and the lower displays.	
<b>SEE ALSO:</b>	SECTION 3.5 " OPERATOR INITIATED ACTIONS"	

## 4. CONFIGURATION

SUB-MATRIX	PARAMETER	CLASSIFICATION
MMI	DISPLAY LO	◆□
<b>DEFINITION:</b>	Type of information displayed on the lower line of the display in the run mode at power on.	
<b>HOW TO MODIFY IT:</b>	Choose a new selection.	
<b>POSSIBLE CHOICES:</b>	<b>Displayed messages:</b>	<b>Explanation:</b>
	<b>ANALOG INPUTS</b>	: Display the analog inputs configured
	<b>2 PVS TRACE</b>	: 2 consecutive channels traces are displayed on the same display line
	<b>COMM RESULTS</b>	: Display communication channels
	<b>ALARM STATUS</b>	: Display alarm states
	<b>SPEED IN USE</b>	: Display of chart speed in use
	<b>DATE &amp; TIME</b>	: Display of date and time
<b>NOTE:</b>	If the selection is the same choice for the 2 displays, displays 1 and 2 are consecutive.	
<b>SEE ALSO:</b>	SECTION 3.5 " OPERATOR INITIATED ACTIONS"	

SUB-MATRIX	PARAMETER	CLASSIFICATION
MMI	BRIGHT	◆□
<b>DEFINITION:</b>	To modify the display brightness during operation.	
<b>HOW TO MODIFY IT:</b>	Choose a new selection. Press the key until the display indicates the right value. Then press <b>ENTER</b> .	
<b>POSSIBLE CHOICES:</b>	<b>OFF (0%)</b>	
	>> <b>(20%)</b>	
	<b>MEDIUM (40%)</b>	
	>> <b>(60%)</b>	
	>> <b>(80%)</b>	
	<b>HIGH (100%)</b>	

## 4. CONFIGURATION

---

<i>SUB-MATRIX</i>	<i>PARAMETER</i>	<i>CLASSIFICATION</i>
<b>MMI</b>	<b>F1 KEY F2 KEY</b>	◆ □

---

**DEFINITION:** Defines the action of the F1 and F2 keys in operation mode.  
The user can define the action of these keys.

**HOW TO MODIFY IT:** . Choose a new selection.

<b>POSSIBLE CHOICES:</b>	<b>Displayed messages:</b>	<b>Explanation:</b>
	<b>UNUSED</b>	: Unused key
	<b>INHIBIT/PRINT</b>	: Stop the printing without data memorization or start.
	<b>RESET PAPER LENG</b>	: Reset value of the paper length configured in the <b>PRINTER</b> sub-matrix.
	<b>CHANGE SPEED</b>	: Change speed/int
	<b>PRINT DATE&amp;TIME</b>	: Print date and time
	<b>SNAP SHOT TRACE</b>	: Print analog PV'S sequence
	<b>CHART ADVANCE</b>	: Advance paper
	<b>CHG GROUP A</b>	: Print group A of channels defined in <b>CHART</b> sub-matrix
	<b>CHG GROUP B</b>	: Print group B of channels defined in <b>CHART</b> sub-matrix
	<b>CHG GROUP A+B</b>	: Print group A+B of channels defined in <b>CHART</b> sub-matrix
	<b>SNAP SHOT LOGIC</b>	: Print the digital inputs
	<b>SNAP SHOT MATH</b>	: Table of maths results
	<b>START/STOP ARCHIVE</b>	: Start or stop archiving on the PCMCIA board
	<b>REMOVE PCMCIA</b>	: Close all PCMCIA files and allow the card extraction

**SEE ALSO:** SECTION 3.5 " OPERATOR INITIATED ACTIONS"

---

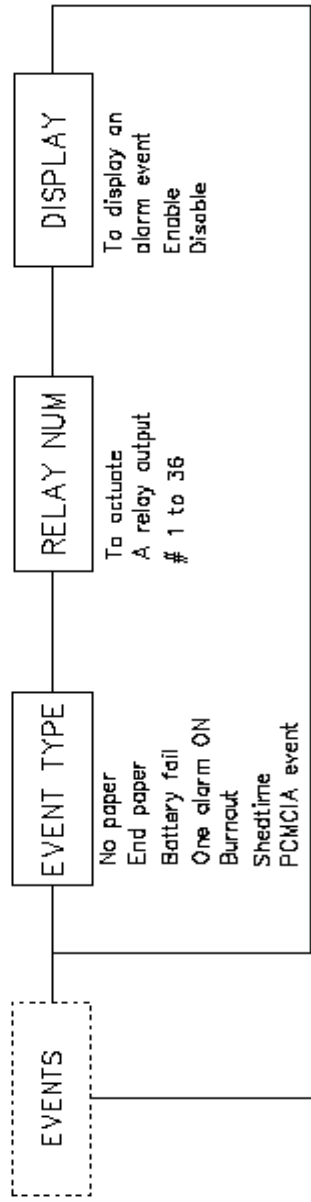
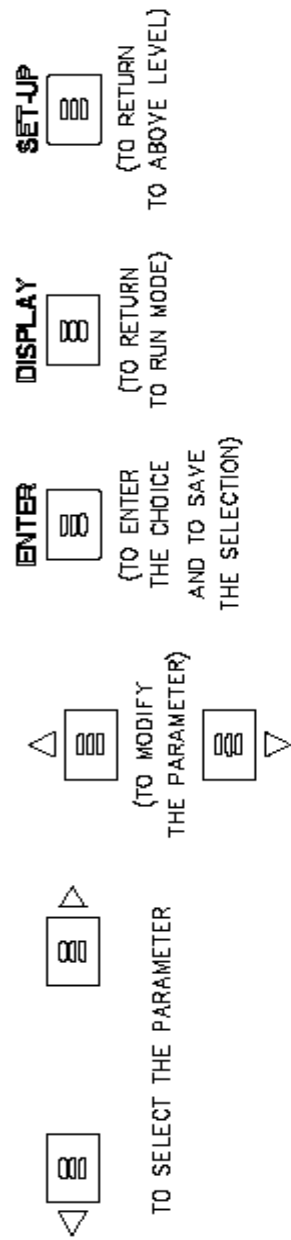

**SUB – MATRIX**

# **EVENTS**

Configuration of recorder events

**PARAMETERS**

**EVENT TYPE** page 4-85

**RELAY NUM** page 4-86

**DISPLAY** page 4-86

## 4. CONFIGURATION

---

*SUB-MATRIX*

*PARAMETER*

*CLASSIFICATION*

---

**EVENTS**

**EVENT TYPE**

---

**DEFINITION:**

Type of recorder event.

**HOW TO MODIFY IT:**

No selection. Parameter cannot be modified, you can only select whether you want to display this Event condition or send the action to relay output.

**POSSIBLE CHOICES:**

**Displayed messages:**

**Explanation:**

EV 01 **NO PAPER**

The recorder has detected no chart paper

EV 02 **END PAPER**

End of the paper length configured in the **PRINTER** matrix

EV 03 **BATTERY FAIL**

The recorder battery has failed

EV 04 **ONE ALARM ON**

There is at least one alarm on

EV 05 **BURNOUT**

There is at least one channel in the recorder burnout

EV 06 **SHEDTIME**

Communication time expired (configured in the communication sub-matrix).  
See Communication Manual.

EV 07 **PCMCIA EVENT**

PCMCIA board is FULL, BAD or NOT INITIALIZED. (See PCMCIA Option Manual).

---

## 4. CONFIGURATION

---

<i>SUB-MATRIX</i>	<i>PARAMETER</i>	<i>CLASSIFICATION</i>
<b>EVENTS</b>	<b>RELAY NUM</b>	◆◆□□

---

**DEFINITION:** Selection of relay activated for each event condition.

**HOW TO MODIFY IT:** Select a new relay number.

**POSSIBLE CHOICES:** **NO RELAY**  
**RELAY # i (i = 1 ... 48)**

**SEE ALSO:** Parameter **RELAY NUM** in sub-matrix **ALARM** and **DIGITAL**.

---

---

<i>SUB-MATRIX</i>	<i>PARAMETER</i>	<i>CLASSIFICATION</i>
<b>EVENTS</b>	<b>DISPLAY</b>	◆□

---

**DEFINITION:** Enable/disable a display indication of the event occurrence.

**HOW TO MODIFY IT:** Choose a new selection.

**POSSIBLE CHOICES:** **ENABLE**  
**DISABLE**

**SEE ALSO:** The burnout event cannot be displayed for sensors and ranges with "Fixed Burnout". (See **ANALOG** sub-matrix, **BURNOUT** parameter.)

---

# 4. CONFIGURATION

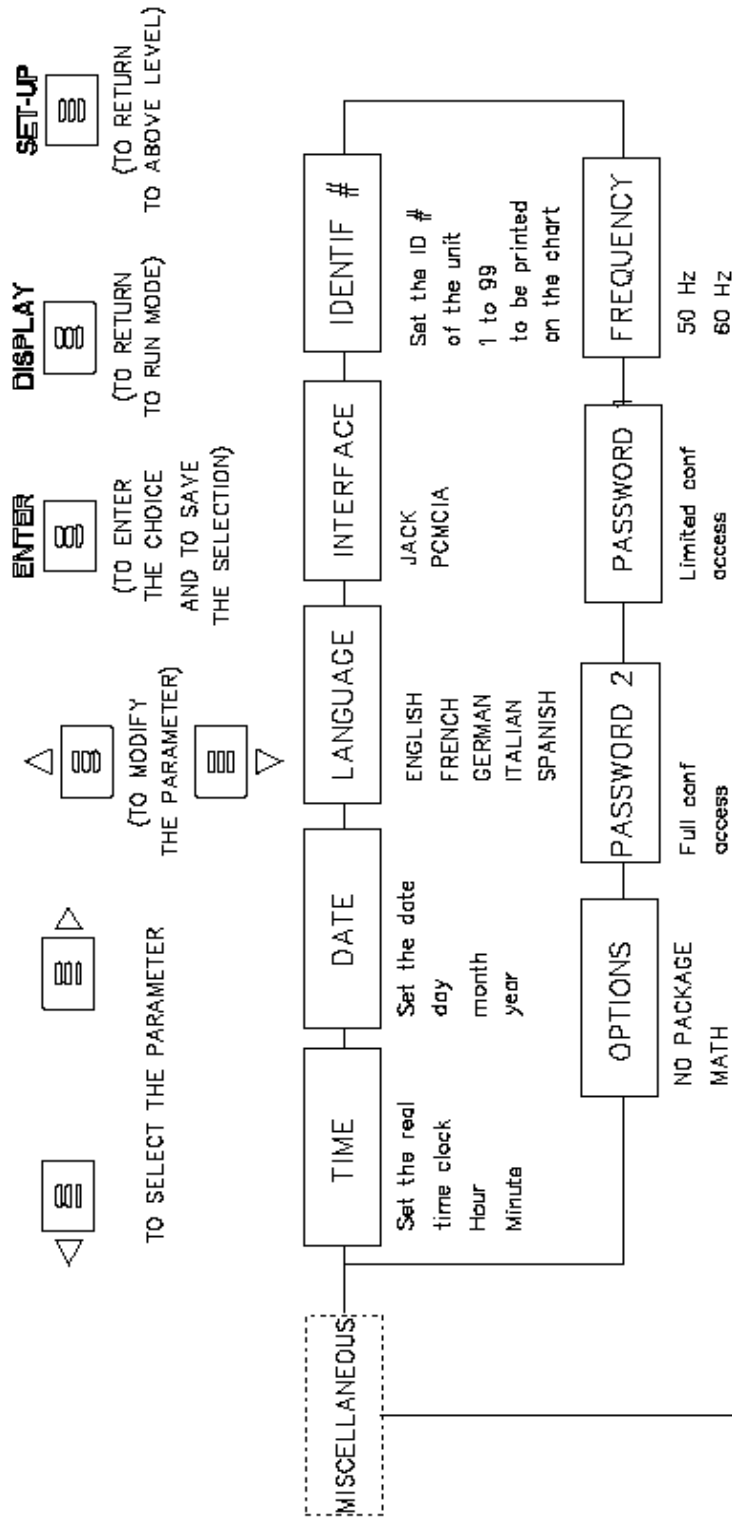



**SUB – MATRIX**

# **MISCELLANEOUS**

**PARAMETERS**

<b>TIME</b>	page 4-89
<b>DATE</b>	page 4-89
<b>LANGUAGE</b>	page 4-90
<b>INTERFACE</b>	page 4-90
<b>IDENTIF #</b>	page 4-91
<b>FREQUENCY</b>	page 4-91
<b>PASSWORD 1</b>	page 4-92
<b>PASSWORD 2</b>	page 4-93
<b>OPTIONS</b>	page 4-94

## 4. CONFIGURATION

---

SUB-MATRIX

PARAMETER

CLASSIFICATION

**MISCEL**

**TIME**



**DEFINITION:** For setting the real time clock.

**HOW TO MODIFY IT:** Enter a new value for hour.  
Then press **ENTER**  
Enter a new value for minutes.  
Then press **ENTER**

**POSSIBLE CHOICES:** 00:00 up to 23:59

---

SUB-MATRIX

PARAMETER

CLASSIFICATION

**MISCEL**

**DATE**



**DEFINITION:** For setting the real time clock date.

**HOW TO MODIFY IT:** Enter a new value for day.  
Then press **ENTER**  
Select a new value for month.  
Then press **ENTER**  
Enter a new value for year.  
Then press **ENTER**

---

## 4. CONFIGURATION

---

<i>SUB-MATRIX</i>	<i>PARAMETER</i>	<i>CLASSIFICATION</i>
<b>MISCEL</b>	<b>LANGUAGE</b>	◆◆□□

---

**DEFINITION:** Operator information and configuration language.

**HOW TO MODIFY IT:** Select a new language.

**POSSIBLE CHOICES:** ENGLISH  
FRENCH  
GERMAN  
SPANISH  
ITALIAN

---

---

<i>SUB-MATRIX</i>	<i>PARAMETER</i>	<i>CLASSIFICATION</i>
<b>MISCEL</b>	<b>INTERFACE</b>	◆◆□□

---

**DEFINITION:** Determines the owner of internal communication between PCMCIA option and JACK.

**HOW TO MODIFY IT:** Select a new value.

**POSSIBLE CHOICES:** JACK  
PCMCIA

**DEFAULT VALUE:** JACK

**NOTE:** PC Configurator cannot modify this parameter.  
PC Configurator is able to communicate with the recorder only if INTERFACE = JACK.

On the contrary, INTERFACE must be equal to PCMCIA if you want to store data on the PCMCIA board (if PCMCIA option is installed).

---

## 4. CONFIGURATION

---

SUB-MATRIX

PARAMETER

CLASSIFICATION

MISCEL

**IDENTIF #**



**DEFINITION:** Identification number of the instrument which will be printed on the chart.

**HOW TO MODIFY IT:** Enter a numeric value.

**POSSIBLE VALUES:** [0 ... 99]

---

SUB-MATRIX

PARAMETER

CLASSIFICATION

MISCEL

**FREQUENCY**



**DEFINITION:** To select the line frequency.

**HOW TO MODIFY IT:** Select a new frequency.

**POSSIBLE CHOICES:** 50 Hz

60 Hz

**NOTE:** This value is important to improve serial mode rejection at supply frequency.  
In case of DC power supply, use the line frequency of the country.

---

## 4. CONFIGURATION

---

<i>SUB-MATRIX</i>	<i>PARAMETER</i>	<i>CLASSIFICATION</i>
<b>MISCEL</b>	<b>PASSWORD 1</b>	◆□□

---

**DEFINITION:** Used to provide a limited access to configuration parameters.

**HOW TO MODIFY IT:** Enter text.

**POSSIBLE CHOICES:** 8 digits max.

**SEE ALSO:** See section 8.1 and the classification in section 9.1.  
See section 4 for configuration matrix.

**NOTE:** The instrument is shipped with no configured password.  
This gives a limited access to configuration. (Parameters with □ )

**NOTE:** If **PASSWORD 1 = PASSWORD 2**, the password will be understood as **PASSWORD 2**.  
If **PASSWORD 1 = PASSWORD 2 = a nil string**, no password will be required for configuration access.

**NOTICE** Do not lose your password code. If you do, contact your service department or technical assistance center.

If using the password function, both **PASSWORD 1 & PASSWORD 2** are required. These can be the same or they can be different.

---

## 4. CONFIGURATION

---

SUB-MATRIX

PARAMETER

CLASSIFICATION

MISCEL

**PASSWORD 2**



**DEFINITION:** Used to provide a limited access to configuration parameters.

**HOW TO MODIFY IT:** Enter text.

**POSSIBLE CHOICES:** 8 digits max.

**SEE ALSO:** See section 8.1 and the classification in section 9.1.  
See section 4 for configuration matrix.

**NOTE:** The instrument is shipped with no configured password.  
This gives a limited access to configuration. (Parameters with  or )

**NOTE:** If **PASSWORD 2 = PASSWORD 1**, the password will be understood as **PASSWORD 2**.  
If **PASSWORD 2 = PASSWORD 1 = a nil string**, no password will be required for configuration access.

**NOTICE** Do not lose your password code. If you do, contact your service department or technical assistance center.

If using the password function, both **PASSWORD 1** & **PASSWORD 2** are required. These can be the same or they can be different.

## 4. CONFIGURATION

---

<i>SUB-MATRIX</i>	<i>PARAMETER</i>	<i>CLASSIFICATION</i>
<b>MISCEL</b>	<b>OPTIONS</b>	◆□□

---

**DEFINITION:** Type of optional maths package.

**HOW TO MODIFY IT:** Enter a code. **(12 capital letters max.)**

**POSSIBLE CHOICES:** If the entered code corresponds to the option code, the following message is displayed: **MATH**  
If not, the following message is displayed: **NO PACKAGE**

**SEE MATH USER'S MANUAL**

**SEE ALSO:** This code should be delivered by your service department and is specific to this recorder.

**NOTE:** To obtain a new code, please indicate the full serial number (13 digits) shown in MISCELLANEOUS sub-matrix, SERIAL # parameter. (See the section 8, "SERVICE")

---

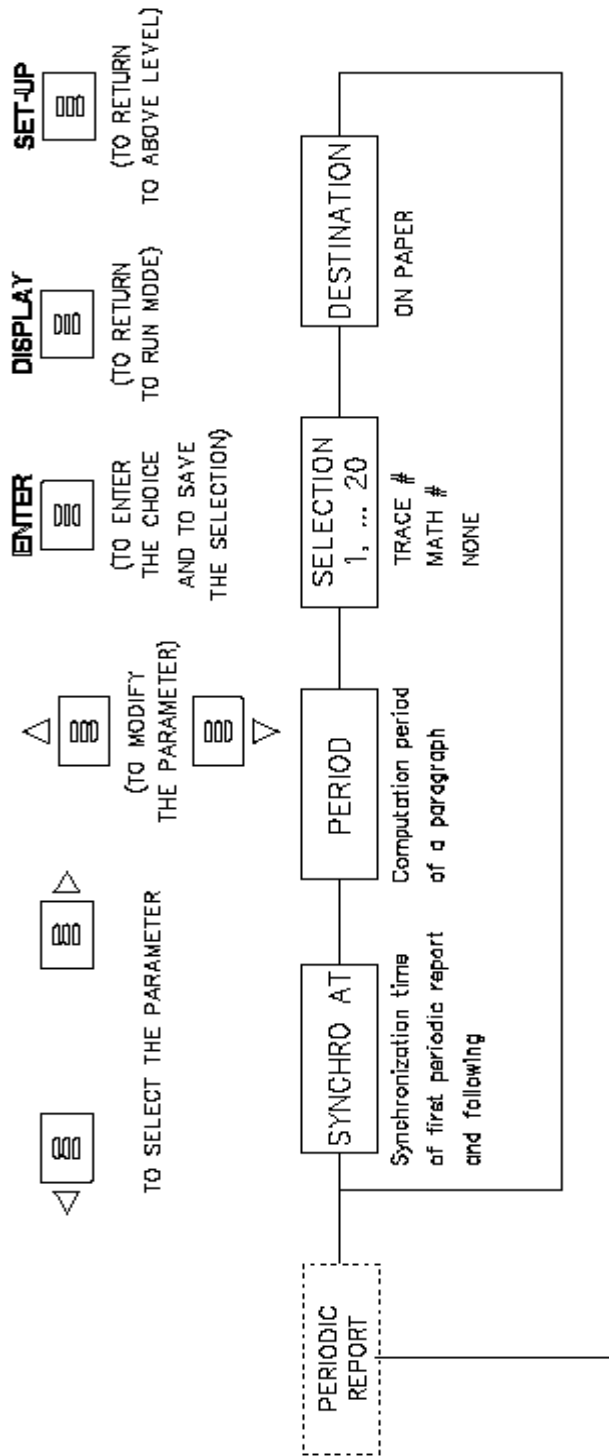



**SUB – MATRIX**

# **PERIODIC REPORT**

**PARAMETERS**

**SYNCHRO AT**

page 4-97

**PERIOD**

page 4-98

**SELECTION 1, ... 20**

page 4-99

**DESTINATION**

page 4-100

## 4. CONFIGURATION

SUB-MATRIX	PARAMETER	CLASSIFICATION
PERIODIC REPORT	SYNCHRO AT	◆◆□□

**DEFINITION:** Synchronization time of first periodic report and following.

**HOW TO MODIFY IT:** Enter a new value for time.

**POSSIBLE CHOICES:** [0 ... 23] hours  
[0 ... 59] minutes

Default value: 00h00

PE01 SYNCHRO AT

00h00

**NOTE:** The periodic report will not be printed in "INHIBIT" mode.  
The first periodic report will be sent when the nearest time will correspond to **[SYNCHRO AT & n(PERIOD)]** time. (accuracy: 1 second)  
"n" is automatically calculated by the recorder so that the synchronization is effective as fast as possible.  
Any configuration modification that stops the acquisitions (with ◆◆ classification) or any restart of the recorder will interrupt the current report and will begin a new one, according to the new parameters.

**EXAMPLE:** 1) Current time: 13h00  
Synchro at: 18h00  
Period: 1.50 (1h30)  
The first periodic report will be sent at 13h30.  
Explanation: 13h30 = 18h00 - 3(1h30)

2) Current date and time: Friday 08/08/1997 at 13h00  
Synchro at: 01h00  
Period: 168 (1 week)  
The first periodic report will be sent on Saturday 09/08/1997, at 01h00.

## 4. CONFIGURATION

---

<i>SUB-MATRIX</i>	<i>PARAMETER</i>	<i>CLASSIFICATION</i>
<b>PERIODIC REPORT</b>	<b>PERIOD</b>	◆◆□□

---

**DEFINITION:** This parameter corresponds to the computation period of a paragraph relative to minimum, average and maximum values for each trace and maths result.

**HOW TO MODIFY IT:** Enter a value between 0 and 720 hours with two significant digits after the decimal point.

**POSSIBLE CHOICES:** 0: no periodic report  
[0.25 ... 720] in hours and hundredths of hours

The chosen values are automatically corrected to the nearest whole minute to obtain the computation period.

**Default value: 0.00 (00h00)**

**NOTE:** You can choose parameters from 0.25 hour (15 mn) to 720 hours (30 days) if you want a periodic report.  
If you do not want any periodic report, configure 0 in this parameter or do not select any trace or maths in the report selection parameter.

**WARNING:** You cannot choose parameter numbers between 0.01 and 0.24 hours. When the recorder prints many messages (ex. CHART DOC, ALARM, DIGITAL ...), some periodic reports may not be printed.

**EXAMPLE:** If the entered value is 0.33, then the computation period is 20 mn.

---

## 4. CONFIGURATION

SUB-MATRIX

PARAMETER

CLASSIFICATION

**PERIODIC  
REPORT**

**SELECTION 01, ... 20**

◆◆□□

**DEFINITION:** Defines every TRACE or MATH that will be computed in the periodic report.

**HOW TO MODIFY IT:** Select each TRACE or MATH you want to use in the periodic report.

**POSSIBLE CHOICES:** TRACE # i (i = 1 ... 32)  
MATH # i (i = 1 ... 32)  
NONE

The structure of **SELECTION 01, ... 20** in the periodic report sub-matrix is similar to **INFORMATION 1, ... 10** in the CHART DOC sub-matrix.

**EXAMPLE:**

```
*** PERIODIC REPORT 14:49 21 OCT 03 ***
```

PE SYNCHRO	AT PERIOD	DESTINATIO	SELECTI 01	SELECTI 02	SELECTI 03
1 00h00	0.33	ON PAPER	TRACE #01	TRACE #02	MATH #02

PE SELECTI 04	SELECTI 05	SELECTI 06	SELECTI 07	SELECTI 08	SELECTI 09
1 TRACE #04	NONE	NONE	NONE	NONE	NONE

PE SELECTI 10	SELECTI 11	SELECTI 12	SELECTI 13	SELECTI 14	SELECTI 15
1 NONE	NONE	NONE	NONE	NONE	NONE

PE SELECTI 16	SELECTI 17	SELECTI 18	SELECTI 19	SELECTI 20
1 NONE	NONE	NONE	NONE	NONE

## 4. CONFIGURATION

SUB-MATRIX

PARAMETER

CLASSIFICATION

PERIODIC REPORT

**DESTINATION**



**DEFINITION:**

Destination where the report will be sent to.

**EXAMPLE:**

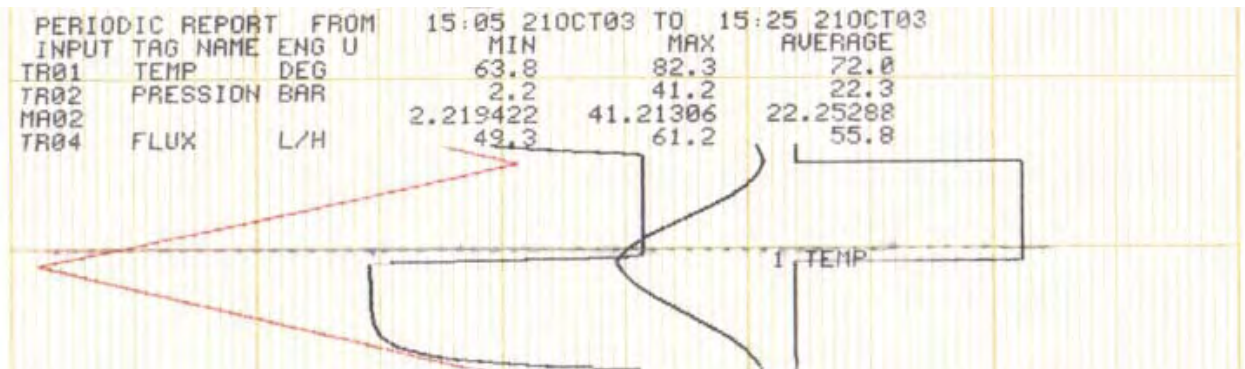

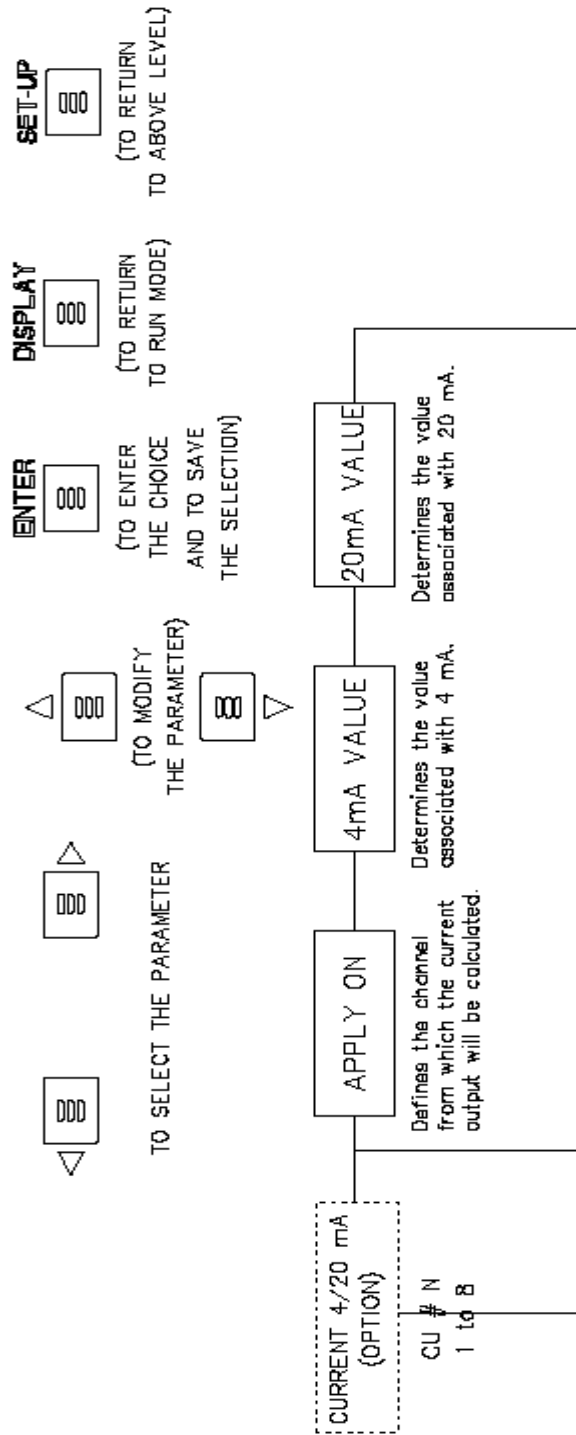

**SUB – MATRIX**

**CURRENT 4/20 mA**

**PARAMETERS**

**APPLY ON**

page 4-103

**4mA VALUE**

page 4-103

**20mA VALUE**

page 4-103

## 4. CONFIGURATION

<i>SUB-MATRIX</i>	<i>PARAMETER</i>	<i>CLASSIFICATION</i>
<b>CURRENT 4/20 mA</b>	<b>APPLY ON</b>	◆◆□□
<b>DEFINITION:</b>	Defines the channel from which the current output would be calculated.	
<b>HOW TO MODIFY IT:</b>	Select a new variable.	
<b>POSSIBLE CHOICES:</b>	NONE ANALOG # i (i = 1 ... 64) MATH # i (i = 1 ... 32) COMM # i (i = 1 ... 32)	
<b>DEFAULT VALUE:</b>	NONE	

<i>SUB-MATRIX</i>	<i>PARAMETER</i>	<i>CLASSIFICATION</i>
<b>CURRENT 4/20 mA</b>	<b>4mA VALUE</b>	◆◆□□
<b>DEFINITION:</b>	Determines the value associated with 4 mA.	
<b>HOW TO MODIFY IT:</b>	Enter a numeric value.	
<b>POSSIBLE CHOICES:</b>	Up to 7 digits plus optional sign and decimal point (optional) according to the associated input type [-9999999 ... 9999999] 3 digits after the decimal point	
<b>DEFAULT VALUE:</b>	-50.000	

<i>SUB-MATRIX</i>	<i>PARAMETER</i>	<i>CLASSIFICATION</i>
<b>CURRENT 4/20 mA</b>	<b>20mA VALUE</b>	◆◆□□
<b>DEFINITION:</b>	Determines the value associated with 20 mA.	
<b>HOW TO MODIFY IT:</b>	Enter a numeric value.	
<b>POSSIBLE CHOICES:</b>	Up to 7 digits plus optional sign and decimal point (optional) according to the associated input type [-9999999 ... 9999999] 3 digits after the decimal point	
<b>DEFAULT VALUE:</b>	150.000	





## 4. CONFIGURATION

### 4.4.2.2 Sub-matrix presentation

Each sub-matrix is shown as a table, and each column represents one parameter of the sub-matrix. See example below relative to the CHART sub-matrix.

CHANNEL #	TRACE	FORMAT	MIN RANGE 1	MAX RANGE 1		0% ZONE	100% ZONE	SUB DIV	GROUP DEF
<i>Customer choice</i>	A B		C	D		L	M	N	O
1									
2									
3									
4									
24									

Each input parameter has a reference containing one letter and one number. (For example, the FORMAT parameter of the third input has the B03 reference.)  
These references are used to identify the source and destination of a copy.

### 4.4.2.3 Procedure

- In COPY mode, select the desired sub-matrix.

**COPY**

**CHART**

Press ENTER after having selected the sub-matrix.  
Press SET UP to return to RUN mode.

- To confirm the CONFIGURATION mode access

**COPY CHART**

**CONFIRM**

"CONFIRM" is blinking. Press ENTER to enter in CONFIGURATION mode  
Press SET UP to return to the previous level.

## 4. CONFIGURATION

---

- To define the left limit of the source copy block:

**COPY CHART**

**FROM A 0 1 O 0 1**

The ▲ and ▼ keys allow you to change the letter on the first character. The character "A" on the second display is proposed by default.

**NOTE:** The letters of numbers (ie A01) correspond to the selection of parameters in each sub-matrix, such as for CHART "A01" is for TRACE channel #1. "B01" would be FORMAT channel #1. (Refer to section 11 "Configuration worksheet").

Press ENTER to confirm your choice and then, to define the source line of the copy.  
Press SET UP to return to the initial display "COPY CHART".

For example: Choose the "B" letter instead of "A".

- To define the line source of the copy:

**COPY CHART**

**FROM B 0 1 O 0 1**

The ◀ and ▶ keys allow you to move between both digits.

The line number proposed by default corresponds to:

- the first available hardware channel for ANALOG and DIGITAL sub-matrices
- "01" for the other sub-matrices

Press ENTER to confirm your selection and to go to the next level.  
Press SET UP to return to the previous writing level.

For example: Choose the "01" line.

## 4. CONFIGURATION

---

- To define the right limit of the source copy block:

**COPY CHART**

**FROM          B0 1      O 0 1**

The ▲ and ▼ keys allow you to change the letter on the first character. The character "O" on the second display is proposed by default and corresponds to the last column of the sub-matrix. It can be changed between "B" (chosen at the previous level) and "O".

The ENTER key allows you to confirm your choice and to define the first destination line of the copy. Press SET UP to return to the previous level.

For example: Choose the "N" letter.

- To define the low limit of the destination block:

**FROM          B01          N01**

**TO              B 0 1**

The ▲ and ▼ keys allow you to change the first digit or the second one of the line number.

The ◀ and ▶ keys allow you to move between both digits.

The ENTER key allows you to confirm your choice and to define the second destination line of the copy. Press SET UP to return to the previous level.

For example: Choose the "03" line.

## 4. CONFIGURATION

---

- To define the high limit of the destination block:

**FROM    B01            N 0 1**

**TO        B03            N 0 3**

The ▲ and ▼ keys allow you to change the first digit or the second one of the line number.

The ◀ and ▶ keys allow you to move between both digits.

The ENTER key allows you to confirm your choice and to execute the copy operations.

Press SET UP to return to the previous level.

- During the copy execution, on the lower display, the bargraph represents the elapsed time.

**COPY**

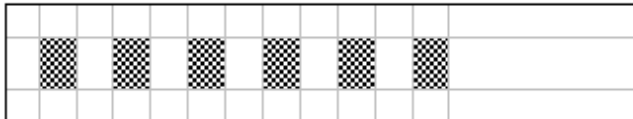

At the end of the copy execution, the initial message is displayed again:

**COPY**

**CHART**

### 4.4.3 WARNING

- The choice of the copy source is only made with consecutive parameters on the same line.
- The copy source can only be a line corresponding to an existing hardware channel in case of ANALOG and DIGITAL sub-matrices.
- The destination can only be composed of consecutive lines.
- For ANALOG sub-matrix only, the source of copy function is necessarily a whole line.

## 4. CONFIGURATION

---

### 4.5 PRINT CONFIGURATION

#### 4.5.1 Introduction

The recorder allows you to print its configuration data.

Two alternative procedures are available:

- **The first procedure should be used when a print-out of all or part of a sub-matrix is required.**  
**ACCESS: In the main menu through PRINT CONF**
- **The second procedure is used when a complete print-out is required.**  
**ACCESS: In Service Printer through PRINT ALL CONF**

If for any reason, part or all of the configured data should be subsequently corrupted or lost; the availability of a hard copy of the recorder configuration will help with the accurate and speedy re-entry of the records configuration.

**ADVICE:** It is recommended that you execute a PRINT ALL CONF after you have configured the recorder and file this away for later reference.

## 4.5.2 Configuration

### 4.5.2.1 Printing all or part of a sub-matrix

#### 4.5.2.1.1 Function access

When the recorder is in RUN mode:

- Press SETUP to enter in CONFIGURATION mode,
- Enter your password,
- Select the sub-matrix with the ▲ and ▼ keys,
- Select the PRINT function with the ◀ and ▶ keys.

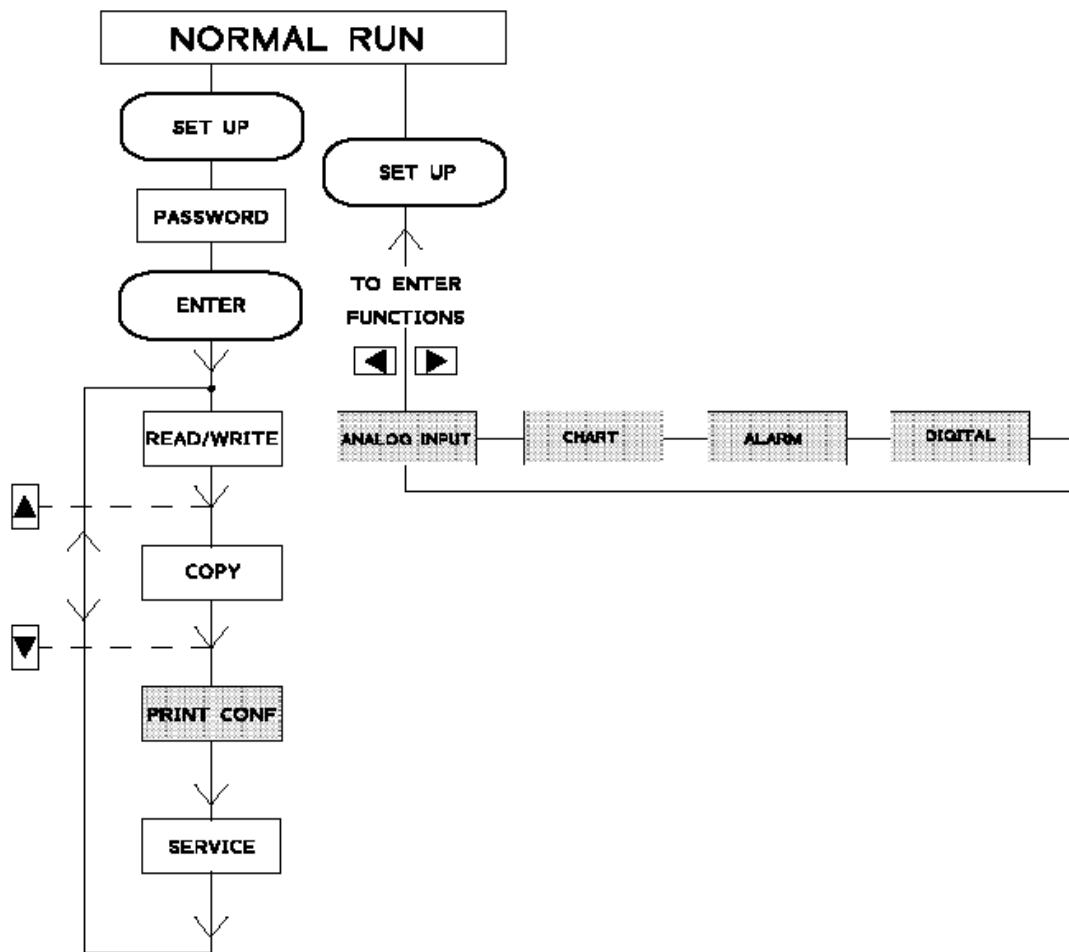

## 4. CONFIGURATION

---

### 4.5.2.1.2 Procedure

- Enter in PRINT mode and select the desired sub-matrix.

**PRINT CONF**

**ANALOG INPUT**

Press ENTER after having selected the sub-matrix.  
Press SET UP to return to RUN mode.

- To confirm the PRINT mode access,

**PRINT CONF**

**CONFIRM**

"CONFIRM" is blinking.  
Press ENTER to confirm the PRINT mode access.  
Press SET UP to return to the previous level.

- To define the low limit number:

**PRINT ANALOG IN**

**FROM LINE**      **0 1**

The ▲ and ▼ keys allow you to change the line numbers.  
The ◀ and ▶ keys allow you to move between both digits.

Press ENTER to confirm your choice. If your written selection is in error (non-existent line number), you will have to define a line number again.  
Press SET UP to return to the initial display "PRINT CONF / ANALOG INPUT".

For example: Choose the line "05".

**NOTE:** Refer to section 11 "Configuration worksheet" for line limits.



## 4. CONFIGURATION

---

- To define the high limit number:

<b>FROM LINE</b>	<b>0 5</b>
------------------	------------

<b>TO LINE</b>	<b>3 2</b>
----------------	------------

The procedure to define this high line number is the same as that for the low line number. The ENTER key allows you to confirm, check and print your selection. Press SET UP to return to the previous level.

- During the printing, the following message is displayed:

<b>PRINT CONF</b>
-------------------

<b>IN PROGRESS</b>
--------------------

- At the end of the printing, the initial message is displayed again:

<b>PRINT CONF</b>
-------------------

<b>ANALOG INPUT</b>
---------------------

### 4.5.2.2 Printing the complete configuration

#### 4.5.2.2.1 *Function access*

#### **NOTICE:**

**TO PRINT THE COMPLETE CONFIGURATION, YOU MUST ENTER IN THE SERVICE MODE.**

(For more information, see section 8 "SERVICE")

**Then to access to the "PRINT ALL CONF" function:**

- Enter in the SERVICE mode,
- Select the PRINT matrix.

## 4. CONFIGURATION

---

### 4.5.2.2.2 Procedure

- Enter in the PRINT mode.

**SERVICE PRINTER**

**PR01 PR ALL CONF**

Press ENTER to have access to this mode.  
Press SET UP to return to RUN mode.

- To confirm access in PRINT mode:

**PR ALL CONF**

**CONFIRM**

"CONFIRM" is blinking.

Press ENTER to confirm access in PRINT mode.  
Press SET UP to return to the previous level.

- During the printing, the following message is displayed:

**PR ALL CONF**

**IN PROGRESS**

- At the end of the printing, the initial message is displayed again:

**SERVICE PRINTER**

**PR01 PR ALL CONF**

## 4. CONFIGURATION

### 4.5.3 Information about printing

- You can stop the printing at any time by pressing the SET UP or DISPLAY keys. All other keys are not active.
- During the printing, a message (IN PROGRESS) is shown on the lower display, indicating the current action.
- At the end of the printing, the initial messages are displayed again and the keys are reactivated.
- The data is printed in reverse order so that you can read it in a logical order from top to bottom when completed.

### 4.5.4 WARNING

- During the printing of one sub-matrix, it is possible to print all the lines or only a few lines. In both cases, these lines are consecutive.
  - Some sub-matrices can change depending on the recorder type. PRINT ALL CONF prints only sub-matrices relative to this recorder. This is true particularly for ANALOG and DIGITAL sub-matrices, whose printed lines correspond to an existing hardware channel.
  - For the MESSAGE sub-matrix, only lines with a non blank message are printed.
  - Accessible passwords in the MISCEL sub-matrix are not printed.
  - To provide the longest printer ribbon life, PRINT ALL CONF alternates the colors automatically:
    - Black for heading
    - Brown, purple, green and blue are alternatively used for the printing of parameter values.
- Printing formats take into account the smallest printing width, which can be defined by the user. The following example represents a printing format you may use:

***ANALOG INPUT 15.55 15 <sup>TH</sup> OCT 96***						
AN#	SENSOR	RANGE	EXT COMP	FILTER	LOW VAL	HIGH VAL
01 RT	D	OHM 0/2000	0.0	5.0	0.00	2000.00
02 RT	D	OHM 0/2000	0.0	5.0	0.00	2000.00
03 RT	D	OHM 0/2000	0.0	5.0	0.00	2000.00
04 RT	D	OHM 0/2000	0.0	5.0	0.00	2000.00
05 RT	D	OHM 0/2000	0.0	5.0	0.00	2000.00
06 RT	D	OHM 0/2000	0.0	5.0	0.00	2000.00
07 RT	D	OHM 0/2000	0.0	5.0	0.00	2000.00
08 RT	D	OHM 0/2000	0.0	5.0	0.00	2000.00
etc.						

AN#	STD MATH	DIFF WITH	BURN OUT	LOW ADJ	HIGH ADJ
01	SQUARE RO	ANALOG #01	FIX HIGH	0.0	1.0
02	SQUARE RO	ANALOG #01	FIX HIGH	0.0	1.0
03	SQUARE RO	ANALOG #01	FIX HIGH	0.0	1.0
04	SQUARE RO	ANALOG #01	FIX HIGH	0.0	1.0
05	SQUARE RO	ANALOG #01	FIX HIGH	0.0	1.0
06	SQUARE RO	ANALOG #01	FIX HIGH	0.0	1.0
07	SQUARE RO	ANALOG #01	FIX HIGH	0.0	1.0
08	SQUARE RO	ANALOG #01	FIX HIGH	0.0	1.0
etc.					

### 4.6 CONFIGURABLE AND PRINTABLE CHARACTERS

0	P	P	0
1	A	a	0
2	B	b	5
3	C	c	R
4	D	d	0
5	E	e	0
6	F	f	2
7	G	g	1
8	H	h	5
9	I	i	1
+	J	j	2
,	K	k	2
-	L	l	2
.	M	m	2
/	N	n	2
?	O	o	

## 4. CONFIGURATION

INDEX	
0% ZONE,	4-27
100% ZONE,	4-27
2 PVS TRACE,	4-79, 4-80
20mA VALUE,	4-102
4mA VALUE,	4-102
50 Hz,	4-90
60 Hz,	4-90
ACK KEY,	4-79
ACKNOWLEDGE,	4-40, 4-51
ACTION,	4-39, 4-50
ALARM TYPE,	4-33
ALARM,	4-31
ALARM HIGH,	4-33
ALARM LOW,	4-33
ALARM STATUS,	4-79, 4-80
ANALOG # i (i = 1 ... 64),	4-16, 4-21, 4-32, 4-38, 4-102
ANALOG INPUT,	4-6
ANALOG INPUTS,	4-79, 4-80
APPLY ON,	4-32, 102
AUTOMATIC,	4-22
B OUT HIGH,	4-17
B OUT LOW,	4-17
BATTERY FAIL,	4-84
BLACK,	4-23, 4-25, 4-41, 4-52, 4-52, 4-55
BLACK THICK,	4-23, 4-25
BLANK,	4-71
BLUE,	4-23, 4-25, 4-41, 4-52, 4-55
BLUE THICK,	4-23, 4-25
BRIGHT,	4-80
BROWN,	4-23, 4-25, 4-41, 4-52, 4-55
BROWN THICK,	4-23, 4-25
BURNOUT,	4-17, 4-84, 4-85
CHANGE SPEED,	4-81
CHANNEL DIFF,	4-15, 4-16
CHART,	4-20
CHART ADVANCE,	4-78, 4-81
CHART DOC,	4-69
CHART LG,	4-67
CHG GROUP A,	4-78, 4-81
CHG GROUP A+B,	4-78, 4-81
CHG GROUP AB,	4-39, 4-50
CHG GROUP B,	4-39, 4-50, 4-78, 4-81
CHG RANGE,	4-39, 4-50
CHG RATE H,	4-33
CHG RATE H, L,	4-33
CHG RATE L,	4-33
CHG SPD/INT,	4-39, 4-50
COMM # i (i = 1 ... 32),	4-21, 4-32, 4-3849, 4-102
COMM RESULTS,	4-79, 4-80
COPY function,	4-103, 4-107
CURRENT 4/20 mA,	4-101, 4-102
DATE,	4-88
DATE & TIME,	4-79, 4-80
DESTINATION,	4-21, 4-99
DIFFERENTIAL,	4-33, 4-48
DIFF WITH,	4-16, 4-38, 4-49
DIG CLOSED,	4-48
DIG OPENED,	4-48
DIGITAL,	4-47
DIGITAL # i (i = 1 ... 48),	4-49
DISABLE,	4-40, 4-51, 4-53, 4-74, 4-77 to 4-79, 4-85
DISPLAY,	4-85
DISPLAY HI,	4-79
DISPLAY LO,	4-80
DISPLAY KEY,	4-77
DIVISION,	4-28
ENABLE,	4-40, 4-51, 4-53, 4-74, 4-77 to 4-79, 4-85
END PAPER,	4-84
ENGLISH,	4-89
ENG UNIT,	4-25
EVENT TYPE,	4-84
EVENTS,	4-83
EXT COM P,	4-12

## 4. CONFIGURATION

F1 KEY,		4-81			
F2 KEY,		4-81			
FILTER,	4	-13			
FIX HIGH,		4-17			
FIX LOW,		4-17			
FIX NONE,		4-17			
FORMAT,	4-22				
FRENCH,	4-89				
FREQUENCY,	4-90				
FUNCT MSG,		4-74			
GERMAN,	4-89				
GREEN,		4-23, 4-25, 4-41,			
		4-52, 4-55			
GREEN THICK,		4-23, 4-25			
GROUP A,		4-29			
GROUP B,		4-29			
GROUP DEF,		4-29			
HIGH ADJUST,		4-18			
HIGH VALUE,		4-14			
HIGH (100%),		4-80			
HOLD KEY,		4-77			
HYSTERESIS,	4-35				
IDENTIF #,		4-90			
INFORMATION 01, ...10,		4-71			
INHIBIT,	4-65,		4-76		
INHIBIT/PRINT,	4-81				
INTERFACE,	4-89				
INTERVAL 1		4-64			
INTERVAL 2,		4-64			
ITALIAN,	4-89				
LANGUAGE,	4-89				
LINEAR,	4-7,		4-9		
LOGIC STATES,		4-79			
LOW ADJUST,	4-18				
LOW VALUE,		4-14			
MATH,	4-93				
MATH RESULTS,		4-79			
MATH # i (i = 1 ... 32),		4-21, 4-32, 4-38,			
		4-98, 4-102			
MAX RANGE 1,		4-23			
MAX RANGE 2,		4-24			
MEDIUM (40%),	4-80				
MESSAGE,	4-56,		4-58		
MESSAGE # i (i = 1 ... 64),		4-41, 4-52, 4-71			
MESSAGE OFF,		4-42, 4-53			
MESSAGE ON,		4-42, 4-53			
MIN RANGE 1,		4-21			
MIN RANGE 2,		4-23			
MMI,	4-76				
MISCELLANEOUS,		4-87			
MSG COLOR,		4-41, 4-52			
MSG NUM,		4-52			
MSG NUMBER,		4-41			
MSG ON/OFF,		4-42, 4-53			
MSG TYPE,		4-42, 4-53			
NEXT RANGE,		4-71			
NO ACTION,		4-39, 4-50			
NO BURNOUT,		4-17			
NO DIVISION,		4-27, 4-28, 4-71			
NO ENTRY,		4-7			
NO GROUP,		4-29			
NO INFORMATION,		4-71			
NO OPT MATH,		4-15			
NO PACKAGE,		4-91			
NO PAPER,		4-84			
NO RELAY,		4-40, 4-51, 4-85			
NO TRACE,		4-21			
NONE,		4-16, 4-33, 4-42,			
		4-48, 4-53, 4-98			
NUMBER,	4-73				
NUMBER & TAG,		4-73			
OCCURRENCE,	4-36				
OFF POSITN,		4-54			
OFF (0%),		4-80			
ON PAPER,		4-121			
ON POSITN,		4-54			
OPTIONS,	4-93				
PASSWORD 1,		4-91			
PASSWORD 2,		4-92			
PERIOD,	4-97				
PERIODIC REPORT,		4-95			
PRINT,	4-65				
PRINT ALL CONF,		4-108, 4-111, 4-113			
PRINT CONFIGURATION		4-108			
PRINT DATE&TIME,		4-78, 4-81			
PRINT GROUP	4-29				
PRINT KEY,		4-78			
PRINT MODE,		4-27, 4-66			
PRINT ON AL,		4-26, 4-39, 4-50			
PRINTER,	4-27,		4-60		
PRT INHIBIT,		4-39, 4-65			
PRT INTRVAL,		4-70			
PRT MATH LOG,		4-39, 4-50			
PURPLE,		4-23, 4-25, 4-41,			
		4-52, 4-55			
PURPLE THICK,		4-23, 4-25			

## 4. CONFIGURATION

<table style="width: 100%; border-collapse: collapse;"> <tr> <td style="width: 30%;">RANGE,</td> <td style="width: 20%;">4-11</td> <td style="width: 50%;"></td> </tr> <tr> <td>RANGE USED,</td> <td></td> <td>4-26</td> </tr> <tr> <td>RANGE # i &amp; chart certification,</td> <td></td> <td>4-71</td> </tr> <tr> <td>RECORD MODE,</td> <td></td> <td>4-65</td> </tr> <tr> <td>RED,</td> <td></td> <td>4-23, 4-25, 4-41, 4-52, 4-55</td> </tr> <tr> <td>RED INAL,</td> <td></td> <td>4-45, 4-55</td> </tr> <tr> <td>RED THICK,</td> <td></td> <td>4-23, 4-25</td> </tr> <tr> <td>RELAY NUM,</td> <td></td> <td>4-30, 4-51, 4-85</td> </tr> <tr> <td>RELAY # i (i = 1 ... 48),</td> <td></td> <td>4-40, 4-51</td> </tr> <tr> <td>RESET ALL MATHS,</td> <td></td> <td>4-78</td> </tr> <tr> <td>RESET ALL OCCUR,</td> <td></td> <td>4-78</td> </tr> <tr> <td>RESET KEY,</td> <td></td> <td>4-78</td> </tr> <tr> <td>RESET MATH #,</td> <td></td> <td>4-78</td> </tr> <tr> <td>RESET OCCURRENCE,</td> <td></td> <td>4-39, 4-78</td> </tr> <tr> <td>RESET PAPER LENG,</td> <td></td> <td>4-78, 4-81</td> </tr> <tr> <td>RG1 COLOR,</td> <td></td> <td>4-23</td> </tr> <tr> <td>RG2 COLOR,</td> <td></td> <td>4-25</td> </tr> <tr> <td>RTD,</td> <td>4-7,</td> <td>4-9</td> </tr> <tr> <td colspan="3"> </td> </tr> <tr> <td>SENSOR,</td> <td>4-7</td> <td></td> </tr> <tr> <td>SELECTION 01, ... 20,</td> <td></td> <td>4-98</td> </tr> <tr> <td>SHEDTIME,</td> <td>4-84</td> <td></td> </tr> <tr> <td>SNAP SHOT ANALOG,</td> <td></td> <td>4-71</td> </tr> <tr> <td>SNAP SHOT LOGIC,</td> <td></td> <td>4-71, 4-78, 4-81</td> </tr> <tr> <td>SNAP SHOT MATH,</td> <td></td> <td>4-71, 4-78, 4-81</td> </tr> <tr> <td>SNAP SHOT TRACE,</td> <td></td> <td>4-71, 4-78, 4-81</td> </tr> <tr> <td>SP VALUE,</td> <td>4-32</td> <td></td> </tr> <tr> <td>SP/ INT USED,</td> <td></td> <td>4-65</td> </tr> <tr> <td>SPANISH,</td> <td>4-89</td> <td></td> </tr> <tr> <td>SPECIAL,</td> <td>4-7</td> <td></td> </tr> <tr> <td>SPEED 1,</td> <td></td> <td>4-63, 4-65</td> </tr> <tr> <td>SPEED 2,</td> <td></td> <td>4-62, 4-65</td> </tr> <tr> <td>SPEED UNIT,</td> <td></td> <td>4-61</td> </tr> <tr> <td>SPEED IN USE,</td> <td></td> <td>4-79, 4-80</td> </tr> <tr> <td>SQUARE ROOT,</td> <td></td> <td>4-15</td> </tr> <tr> <td>STD MATH,</td> <td></td> <td>4-15</td> </tr> <tr> <td>STD MESSAGE,</td> <td></td> <td>4-42, 4-53</td> </tr> <tr> <td>SUB DIV,</td> <td></td> <td>4-28</td> </tr> <tr> <td>SYNCHRO AT,</td> <td></td> <td>4-96</td> </tr> <tr> <td colspan="3"> </td> </tr> <tr> <td>TABULAR,</td> <td>4-66</td> <td></td> </tr> <tr> <td>TAB SQBLANK,</td> <td></td> <td>4-39, 4-50</td> </tr> <tr> <td>TAB SQTRACE,</td> <td></td> <td>4-39, 4-50</td> </tr> <tr> <td>TAG NAME,</td> <td></td> <td>4-26</td> </tr> <tr> <td>T/C EXT COMP,</td> <td></td> <td>4-7</td> </tr> <tr> <td>T/C INT COMP,</td> <td></td> <td>4-7</td> </tr> <tr> <td>TIME,</td> <td>4-88</td> <td></td> </tr> <tr> <td>TRACE,</td> <td>4-21,</td> <td>4-53</td> </tr> <tr> <td>TRACE COLOR,</td> <td></td> <td>4-55</td> </tr> <tr> <td>TRACE IN ALARM,</td> <td></td> <td>4-79</td> </tr> <tr> <td>TRACE REF,</td> <td></td> <td>4-73</td> </tr> <tr> <td>TRACE # i (i = 1 ... 32),</td> <td></td> <td>4-98</td> </tr> <tr> <td>TRACE &amp; TAG,</td> <td></td> <td>4-79</td> </tr> </table>	RANGE,	4-11		RANGE USED,		4-26	RANGE # i & chart certification,		4-71	RECORD MODE,		4-65	RED,		4-23, 4-25, 4-41, 4-52, 4-55	RED INAL,		4-45, 4-55	RED THICK,		4-23, 4-25	RELAY NUM,		4-30, 4-51, 4-85	RELAY # i (i = 1 ... 48),		4-40, 4-51	RESET ALL MATHS,		4-78	RESET ALL OCCUR,		4-78	RESET KEY,		4-78	RESET MATH #,		4-78	RESET OCCURRENCE,		4-39, 4-78	RESET PAPER LENG,		4-78, 4-81	RG1 COLOR,		4-23	RG2 COLOR,		4-25	RTD,	4-7,	4-9				SENSOR,	4-7		SELECTION 01, ... 20,		4-98	SHEDTIME,	4-84		SNAP SHOT ANALOG,		4-71	SNAP SHOT LOGIC,		4-71, 4-78, 4-81	SNAP SHOT MATH,		4-71, 4-78, 4-81	SNAP SHOT TRACE,		4-71, 4-78, 4-81	SP VALUE,	4-32		SP/ INT USED,		4-65	SPANISH,	4-89		SPECIAL,	4-7		SPEED 1,		4-63, 4-65	SPEED 2,		4-62, 4-65	SPEED UNIT,		4-61	SPEED IN USE,		4-79, 4-80	SQUARE ROOT,		4-15	STD MATH,		4-15	STD MESSAGE,		4-42, 4-53	SUB DIV,		4-28	SYNCHRO AT,		4-96				TABULAR,	4-66		TAB SQBLANK,		4-39, 4-50	TAB SQTRACE,		4-39, 4-50	TAG NAME,		4-26	T/C EXT COMP,		4-7	T/C INT COMP,		4-7	TIME,	4-88		TRACE,	4-21,	4-53	TRACE COLOR,		4-55	TRACE IN ALARM,		4-79	TRACE REF,		4-73	TRACE # i (i = 1 ... 32),		4-98	TRACE & TAG,		4-79	<table style="width: 100%; border-collapse: collapse;"> <tr> <td style="width: 30%;">TREND,</td> <td style="width: 20%;">4-27,</td> <td style="width: 50%;">4-66</td> </tr> <tr> <td>TR NL 0-20mA,</td> <td></td> <td>4-7</td> </tr> <tr> <td>TR NL 0-5V,</td> <td></td> <td>4-7</td> </tr> <tr> <td>TR NL 1-5V,</td> <td></td> <td>4-7</td> </tr> <tr> <td>TR NL 4-20mA,</td> <td></td> <td>4-7</td> </tr> <tr> <td>TYPE,</td> <td>4-48</td> <td></td> </tr> <tr> <td colspan="3"> </td> </tr> <tr> <td>UNIT = inch/h,</td> <td></td> <td>4-61</td> </tr> <tr> <td>UNIT = mm/h,</td> <td></td> <td>4-61</td> </tr> <tr> <td>UNUSED,</td> <td>4-81</td> <td></td> </tr> <tr> <td colspan="3"> </td> </tr> <tr> <td>X.XXX (1/1000) 1.000,</td> <td></td> <td>4-22</td> </tr> <tr> <td>XX.XX (1/100) 10.00,</td> <td></td> <td>4-22</td> </tr> <tr> <td>XXX.X (1/10) 100.0,</td> <td></td> <td>4-22</td> </tr> <tr> <td>XXXXX (no decimal point) 10000,</td> <td></td> <td>4-22</td> </tr> </table>	TREND,	4-27,	4-66	TR NL 0-20mA,		4-7	TR NL 0-5V,		4-7	TR NL 1-5V,		4-7	TR NL 4-20mA,		4-7	TYPE,	4-48					UNIT = inch/h,		4-61	UNIT = mm/h,		4-61	UNUSED,	4-81					X.XXX (1/1000) 1.000,		4-22	XX.XX (1/100) 10.00,		4-22	XXX.X (1/10) 100.0,		4-22	XXXXX (no decimal point) 10000,		4-22
RANGE,	4-11																																																																																																																																																																																																												
RANGE USED,		4-26																																																																																																																																																																																																											
RANGE # i & chart certification,		4-71																																																																																																																																																																																																											
RECORD MODE,		4-65																																																																																																																																																																																																											
RED,		4-23, 4-25, 4-41, 4-52, 4-55																																																																																																																																																																																																											
RED INAL,		4-45, 4-55																																																																																																																																																																																																											
RED THICK,		4-23, 4-25																																																																																																																																																																																																											
RELAY NUM,		4-30, 4-51, 4-85																																																																																																																																																																																																											
RELAY # i (i = 1 ... 48),		4-40, 4-51																																																																																																																																																																																																											
RESET ALL MATHS,		4-78																																																																																																																																																																																																											
RESET ALL OCCUR,		4-78																																																																																																																																																																																																											
RESET KEY,		4-78																																																																																																																																																																																																											
RESET MATH #,		4-78																																																																																																																																																																																																											
RESET OCCURRENCE,		4-39, 4-78																																																																																																																																																																																																											
RESET PAPER LENG,		4-78, 4-81																																																																																																																																																																																																											
RG1 COLOR,		4-23																																																																																																																																																																																																											
RG2 COLOR,		4-25																																																																																																																																																																																																											
RTD,	4-7,	4-9																																																																																																																																																																																																											
SENSOR,	4-7																																																																																																																																																																																																												
SELECTION 01, ... 20,		4-98																																																																																																																																																																																																											
SHEDTIME,	4-84																																																																																																																																																																																																												
SNAP SHOT ANALOG,		4-71																																																																																																																																																																																																											
SNAP SHOT LOGIC,		4-71, 4-78, 4-81																																																																																																																																																																																																											
SNAP SHOT MATH,		4-71, 4-78, 4-81																																																																																																																																																																																																											
SNAP SHOT TRACE,		4-71, 4-78, 4-81																																																																																																																																																																																																											
SP VALUE,	4-32																																																																																																																																																																																																												
SP/ INT USED,		4-65																																																																																																																																																																																																											
SPANISH,	4-89																																																																																																																																																																																																												
SPECIAL,	4-7																																																																																																																																																																																																												
SPEED 1,		4-63, 4-65																																																																																																																																																																																																											
SPEED 2,		4-62, 4-65																																																																																																																																																																																																											
SPEED UNIT,		4-61																																																																																																																																																																																																											
SPEED IN USE,		4-79, 4-80																																																																																																																																																																																																											
SQUARE ROOT,		4-15																																																																																																																																																																																																											
STD MATH,		4-15																																																																																																																																																																																																											
STD MESSAGE,		4-42, 4-53																																																																																																																																																																																																											
SUB DIV,		4-28																																																																																																																																																																																																											
SYNCHRO AT,		4-96																																																																																																																																																																																																											
TABULAR,	4-66																																																																																																																																																																																																												
TAB SQBLANK,		4-39, 4-50																																																																																																																																																																																																											
TAB SQTRACE,		4-39, 4-50																																																																																																																																																																																																											
TAG NAME,		4-26																																																																																																																																																																																																											
T/C EXT COMP,		4-7																																																																																																																																																																																																											
T/C INT COMP,		4-7																																																																																																																																																																																																											
TIME,	4-88																																																																																																																																																																																																												
TRACE,	4-21,	4-53																																																																																																																																																																																																											
TRACE COLOR,		4-55																																																																																																																																																																																																											
TRACE IN ALARM,		4-79																																																																																																																																																																																																											
TRACE REF,		4-73																																																																																																																																																																																																											
TRACE # i (i = 1 ... 32),		4-98																																																																																																																																																																																																											
TRACE & TAG,		4-79																																																																																																																																																																																																											
TREND,	4-27,	4-66																																																																																																																																																																																																											
TR NL 0-20mA,		4-7																																																																																																																																																																																																											
TR NL 0-5V,		4-7																																																																																																																																																																																																											
TR NL 1-5V,		4-7																																																																																																																																																																																																											
TR NL 4-20mA,		4-7																																																																																																																																																																																																											
TYPE,	4-48																																																																																																																																																																																																												
UNIT = inch/h,		4-61																																																																																																																																																																																																											
UNIT = mm/h,		4-61																																																																																																																																																																																																											
UNUSED,	4-81																																																																																																																																																																																																												
X.XXX (1/1000) 1.000,		4-22																																																																																																																																																																																																											
XX.XX (1/100) 10.00,		4-22																																																																																																																																																																																																											
XXX.X (1/10) 100.0,		4-22																																																																																																																																																																																																											
XXXXX (no decimal point) 10000,		4-22																																																																																																																																																																																																											

## ***4. CONFIGURATION***

---



## 5. PC CONFIGURATION

---

### TABLE OF CONTENTS

5.1	OVERVIEW.....	5-2
5.2	INSTALLING THE SOFTWARE ON YOUR SYSTEM.....	5-2
5.2.1	Minimum system requirements.....	5-2
5.2.2	Installation.....	5-3
5.2.3	Language setting .....	5-4
5.3	INSTALLING THE FIRMWARE FOR YOUR RECORDER OR FOR YOUR COMMUNICATION BOARD 4	
5.4	PC - RECORDER INTERFACE.....	5-4
5.4.1	Connections.....	5-4
5.5	STARTING PC CONFIGURATOR.....	5-6
5.5.1	Start the program.....	5-6
5.5.2	Main menu .....	5-6
5.5.3	Set up communication .....	5-6
5.6	FILE MENU .....	5-7
5.6.1	New configuration .....	5-7
5.6.2	Open configuration .....	5-9
5.6.3	Close, Save , Save As .....	5-10
5.6.4	Remove configuration.....	5-11
5.6.5	Print screen.....	5-11
5.6.6	Print configuration.....	5-12
5.6.7	Export.....	5-13
5.6.8	Import.....	5-14
5.6.9	Exit.....	5-14
5.7	VIEW MENU .....	5-14
5.8	ON-LINE COMM MENU .....	5-14
5.8.1	Device .....	5-14
5.8.2	Communication parameters .....	5-15
5.8.3	Upload configuration.....	5-15
5.8.4	Download configuration .....	5-16
5.8.5	Upgrade Firmware: Firmware Files Installer .....	5-17
5.8.6	Upgrade Firmware: Main firmware .....	5-18
5.8.7	Upgrade Firmware: Communication firmware.....	5-19
5.8.8	Services .....	5-20
5.9	USER ACTUATION MENU.....	5-21
5.9.1	Edit User Actuation File .....	5-21
5.9.2	Add User actuation to Configuration.....	5-22
5.10	OPTIONS MENU .....	5-23
5.10.1	Copy line.....	5-23
5.11	WINDOW MENU.....	5-23
5.12	ABOUT.....	5-23
5.13	ERROR MESSAGES.....	5-24

## 5. PC CONFIGURATION

---

### IMPORTANT:

The PC Configurator supports recorder firmware version 001AN or later.

The PC Configurator can upload configurations from recorders with earlier firmware versions. Versions 001AA and earlier require upgrade to latest firmware version; versions 001AB and later do not require upgrade although it is recommended.

The recorder Firmware upgrade (Refer to page 5-18) and the communication Firmware upgrade (Refer to page 5-19) are part of the PC Configurator menu and are only executed via the jack cable.

### REMINDER:

You can identify the recorder Firmware issue or the communication Firmware issue by pressing SETUP, then going to SERVICE menu and MISCELLANEOUS sub-matrix (recorder) or COMM sub-matrix.

## 5.1 OVERVIEW

The PC Configurator enables you to configure your recorder through a Windows™ interface. It provides the following functionalities:

- Configuration Upload/Download
- Recorder Firmware Upgrade or communication Firmware Upgrade

To run this application efficiently, we recommend you first close all other PC applications.

### NOTES:

- All menus and screens are accessible with or without a mouse.
- For general information, choose the **"ABOUT"** dialog box in the main menu.

## 5.2 INSTALLING THE SOFTWARE ON YOUR SYSTEM

### 5.2.1 Minimum System Requirements

**NOTE:** Make sure you are an "Administrator" before installing the product

- Windows 7 Professional, Ultimate or Enterprise OS 32-bit or 64-bit edition requires 1 GHz Processor, 2GB RAM and 15GB Hard Disk Space
- Windows XP SP1 professional requires a 233 Mhz CPU with 128 MB of RAM
- Windows 2000 SP4 professional requires a Pentium 133 Mhz CPU with 64 MB of RAM
- Windows NT Workstation 4.0 SP5 requires a 486 Mhz CPU with 32 MB of RAM
- Windows 98SE requires a Pentium 150MHz processor with 32 MB of RAM
- 10MB free on your hard disk for the PC Configuration software.
- Recommended video resolution: 800x600 or higher.
- RS232 as serial port 1

## 5. PC CONFIGURATION

---

### 5.2.2 Installation

- Insert the Configurator CD. Program should autorun to begin installation. If not, go to Windows Explorer and click on the CD drive, then double-click “Autorun.exe” The following popup appears:



- Click “Install/Uninstall.”
- Click Next button on the Welcome screen
- Input the User name and Company name and click the Next button
- Input the destination folder and click the Next button
- Setup performs automatic migration of the user created configuration database files if they exist in the destination directory.
- Select the language, and click the Next button.
- Exit the popup.

**NOTE:** The choice of the language (English, French, German) is defined at the PC Configurator installation. This choice cannot be modified after the installation. Only the PC Configurator reinstallation allows you to choose another language.

## 5. PC CONFIGURATION

### 5.2.3 Language setting

To change the language used by PC Configurator:

1. Click on Start, Programs, DPR 180\_250 PC Configurator, Language Preferences & Readme . The following dialog is launched.

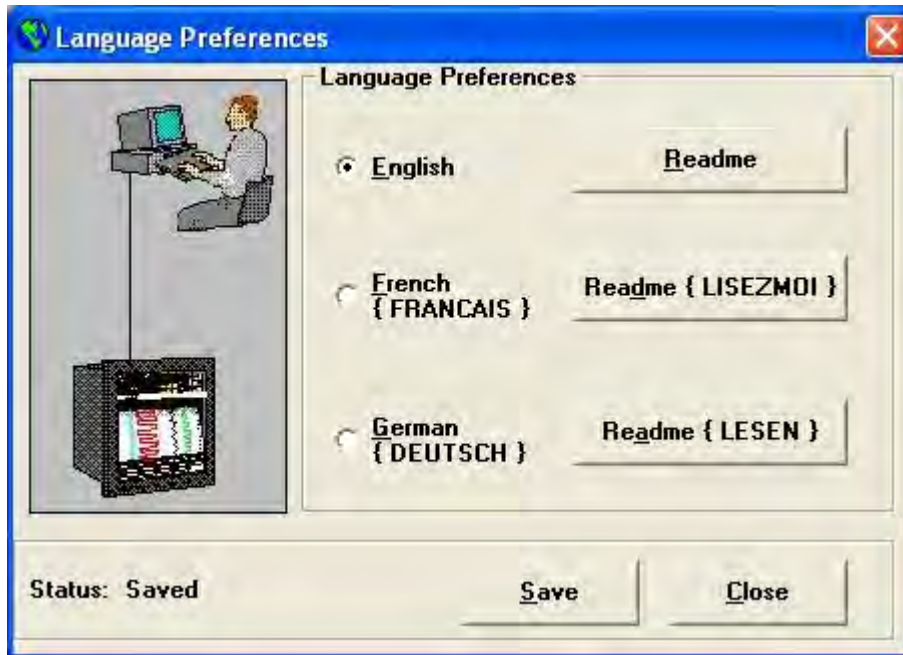

2. Select the required language.
3. Click on save
4. Execute the application to see the change in language.

### 5.3 INSTALLING THE FIRMWARE FOR YOUR RECORDER OR FOR YOUR COMMUNICATION BOARD

The following procedure allows you to install new Firmware versions on your PC (the Firmware for your recorder or the Firmware for your communication board).

- Insert the Firmware CD.
- Double-click on "Upgrade Firmware Setup" icon.
- Follow the instructions.

### 5.4 PC - RECORDER INTERFACE

#### 5.4.1 Connections

To communicate with your recorder, you need the PC Interface Kit 46190409-501, which includes the application software for your recorder configuration. This kit is composed of:

- one PC interface box. (Plug it directly into the PC serial port.)

## 5. PC CONFIGURATION

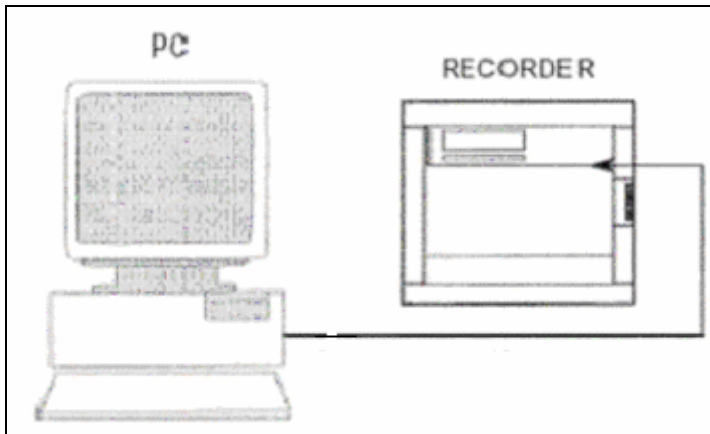

- one jack cable between the interface box and the recorder. Plug the jack cable into your recorder as shown below.

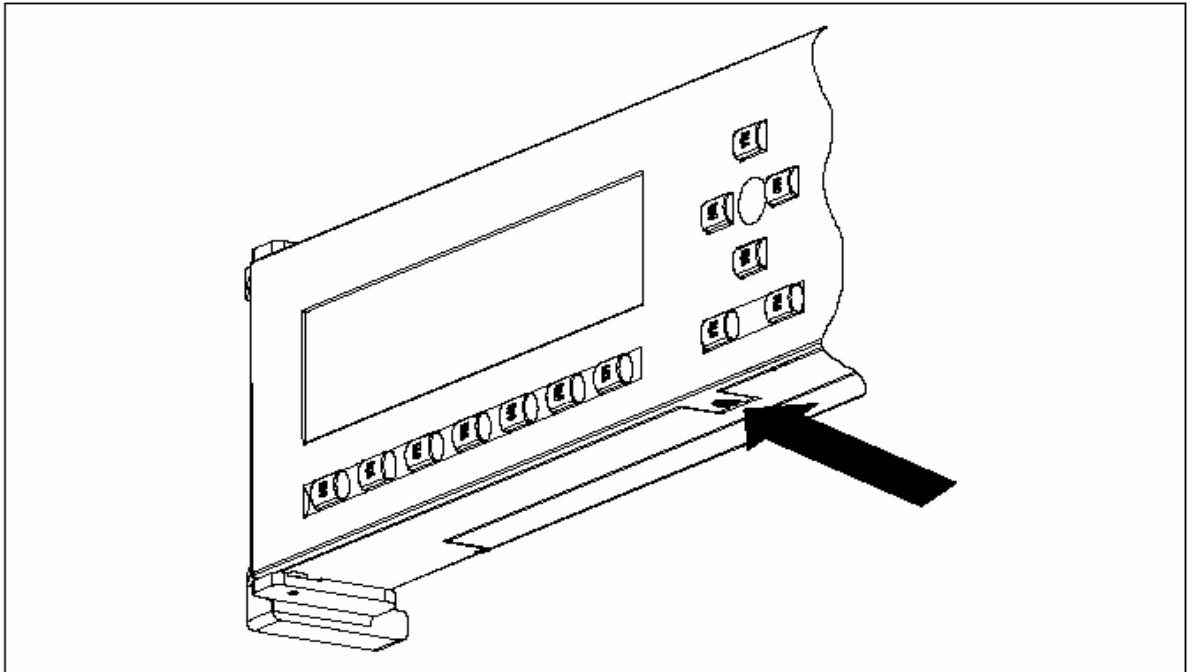

### ATTENTION

Only one recorder can be connected to the communication link.

### 5.5 STARTING PC CONFIGURATOR

#### 5.5.1 Start the program



- Click on desktop icon DPR 180\_250 P... or
- Start menu, Programs, DPR180\_250 PC Configurator.

#### 5.5.2 Main menu

The application can be launched from the startup menu and the icon on the desktop. The following display appears.

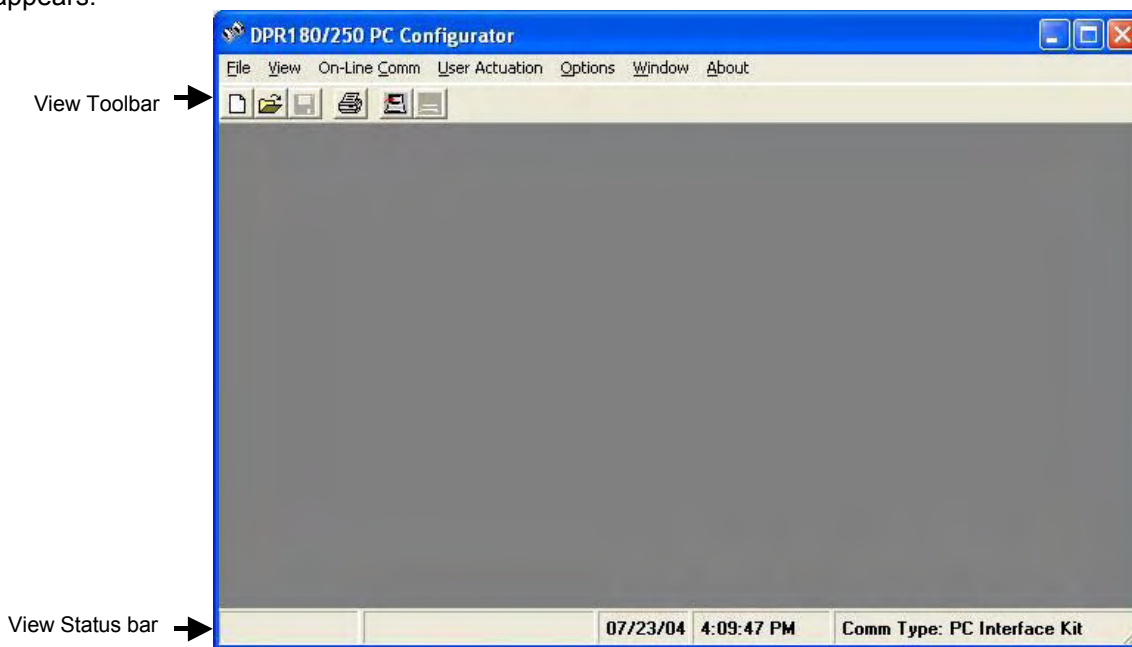

#### 5.5.3 Set up communication

- Select "On-line Comm."
- Select Device type (DPR180 or DPR250).
- Select "Communication Parameters."
- Select the PC-port (COM 1 or COM 2) to which you have connected your interface. Select communication type (PC Interface Kit or RS485) and recorder address (1-255).
- A message will be displayed for communication errors.

### 5.6 FILE MENU

#### 5.6.1 New configuration

Select the type of recorder configuration from the drop down list.



Select Ok to display the following window.

## 5. PC CONFIGURATION

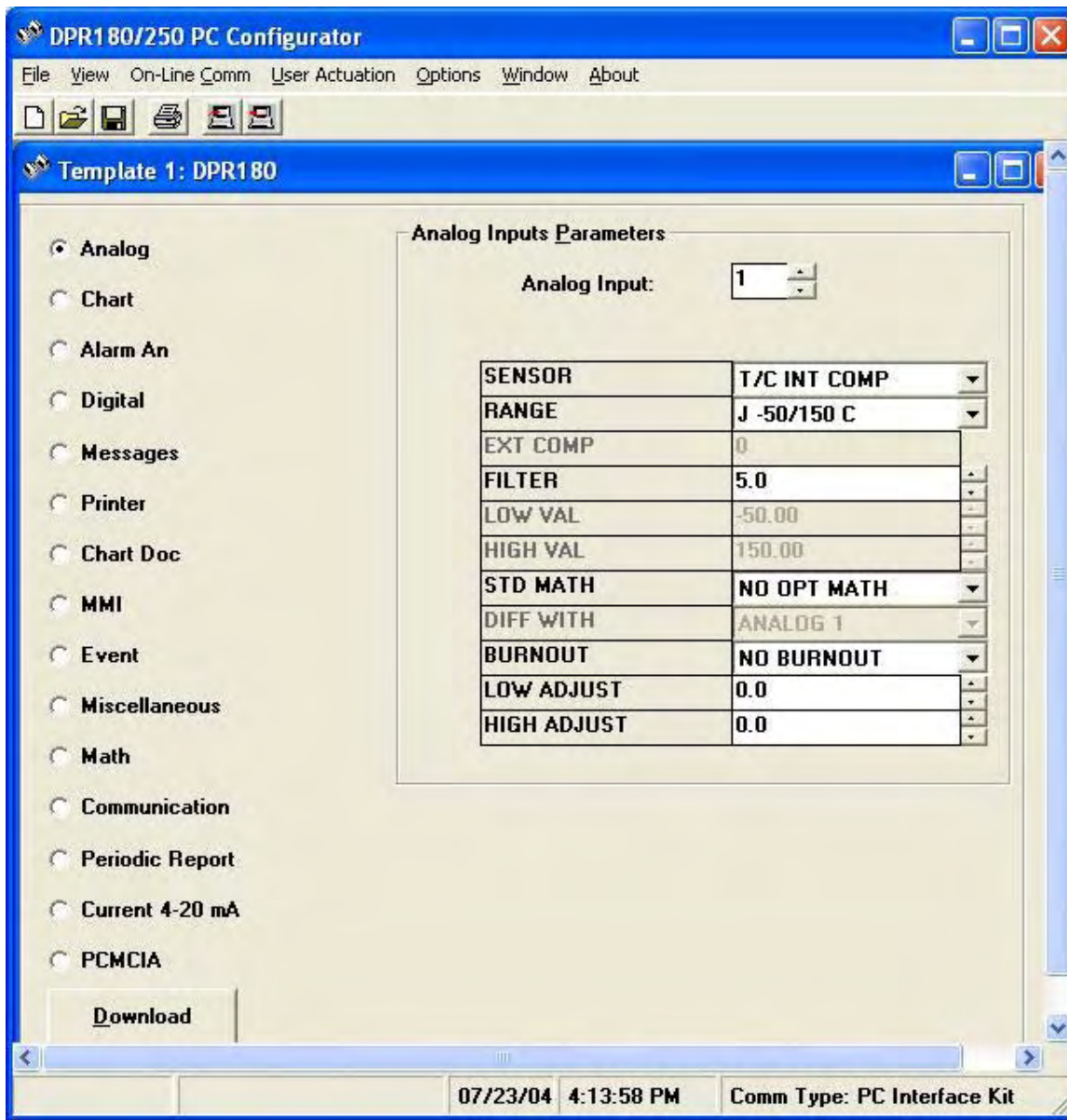

The options buttons on the left side access the different matrices of the recorder. The boxes on the right configure parameters for each of the matrices.



### 5.6.2 Open configuration

Existing (saved) configuration information can be opened by selecting “Open Configuration” in the File menu

If the existing configuration is in binary format, select “Binary” file type, then select the file name as indicated below.

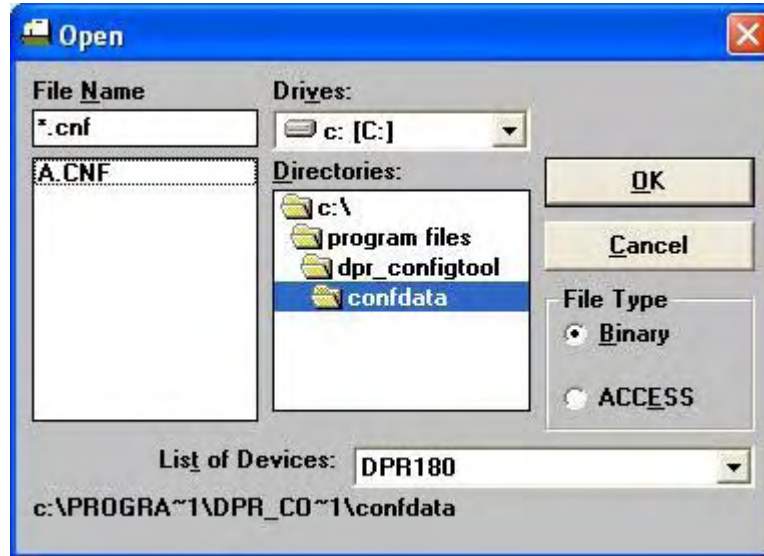

If the existing configuration is in database format, select “ACCESS” file type, then select the tag name as indicated below.

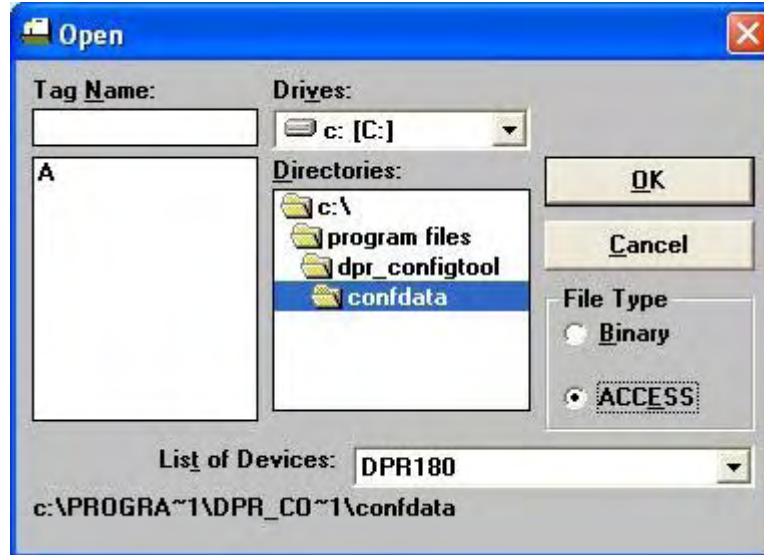

## 5. PC CONFIGURATION

### 5.6.3 Close, Save , Save As

Select Close to close the configuration without saving.

Select Save to save all changes to the configuration.

Select Save As to save all changes under a new file name and file type.

File type can be in Microsoft Access or binary. Access format lets you store many configurations in one database file for easier maintainability. Binary format requires a separate file for each configuration.

If the configuration is being stored for the first time in binary format, input the configuration file name by selecting file type as "Binary" as indicated below.

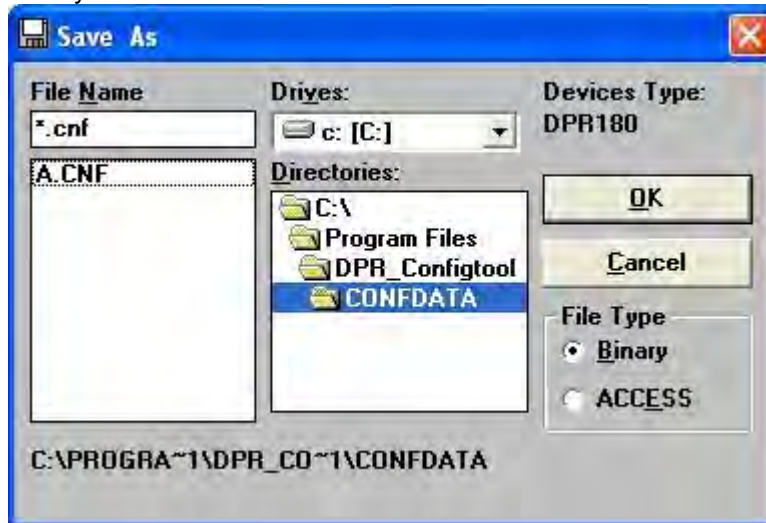

If the configuration is being stored for the first time in Access database, input the configuration tag name by selecting file type as "ACCESS" as indicated below.

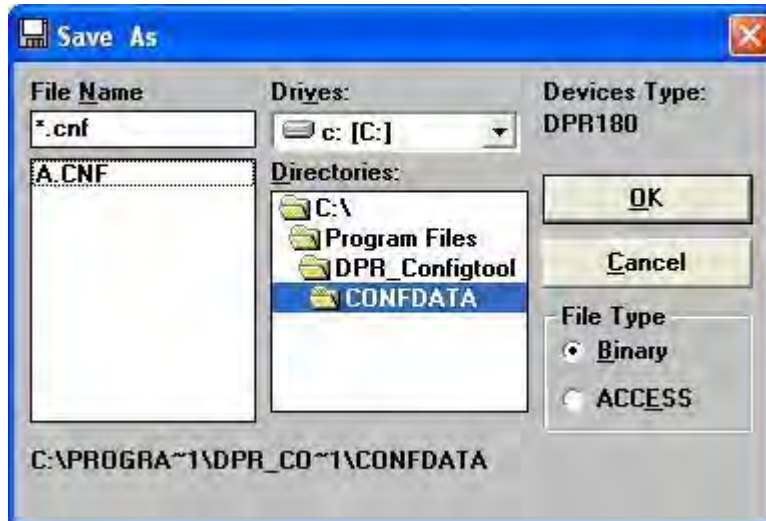

### 5.6.4 Remove configuration

This dialog box can be accessed by selecting "Remove Configuration" from the File menu. A configuration can be removed from the database by specifying the tag name in the below dialog box.

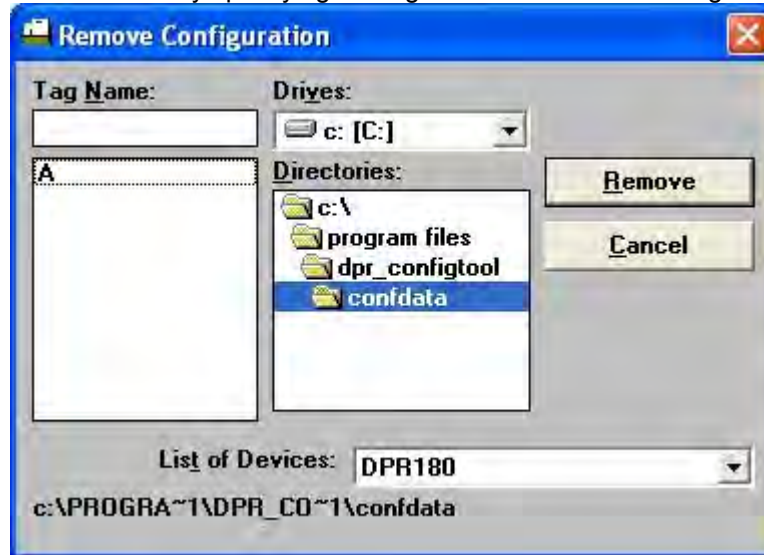

### 5.6.5 Print screen

Prints the currently displayed parameters as they appear onscreen.

## 5. PC CONFIGURATION

### 5.6.6 Print configuration

Prints an entire configuration (all parameters and their values/settings). The following window is displayed:

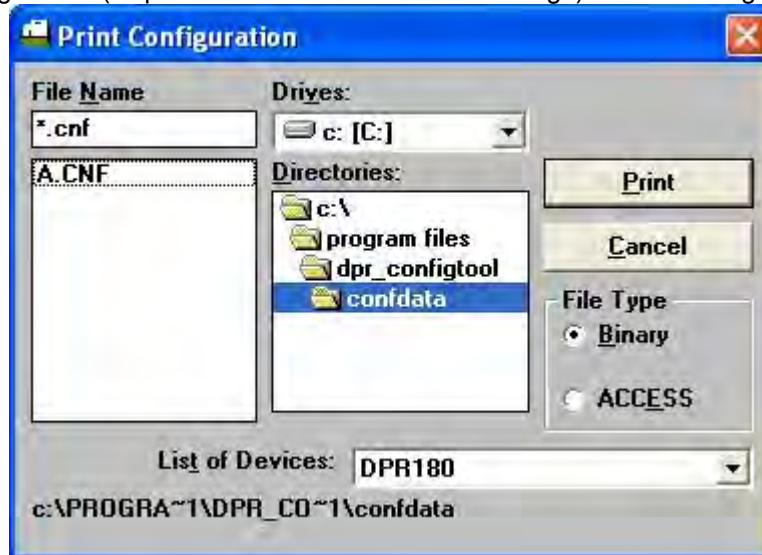

Select File Type Binary or Access.

If the File Type is Binary, select the file name of the configuration, then Print or Cancel.

If the File Type is Access database format, select the tag name as shown below. Select Print or Cancel.

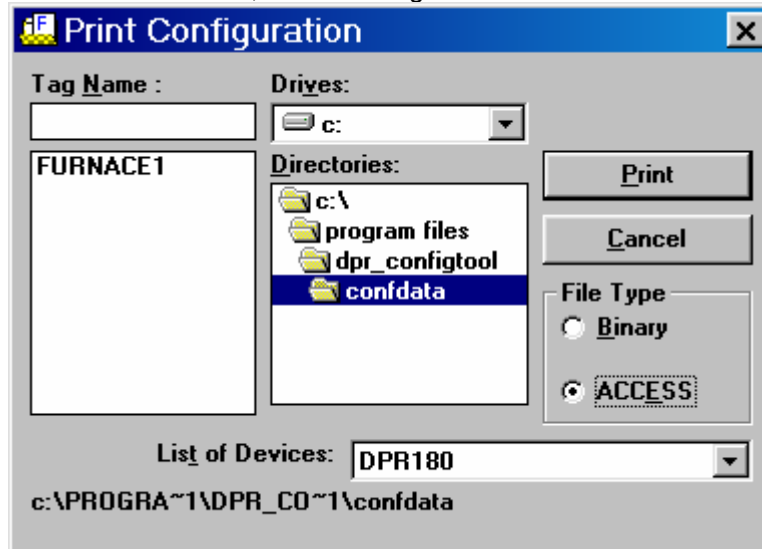

Note: The print format in PC Configurator 7.2 would be retained for the new version of the tool.

### 5.6.7 Export

Export transfers one configuration via a floppy disk or a hard disk. The configuration is stored with the .exp file extension.

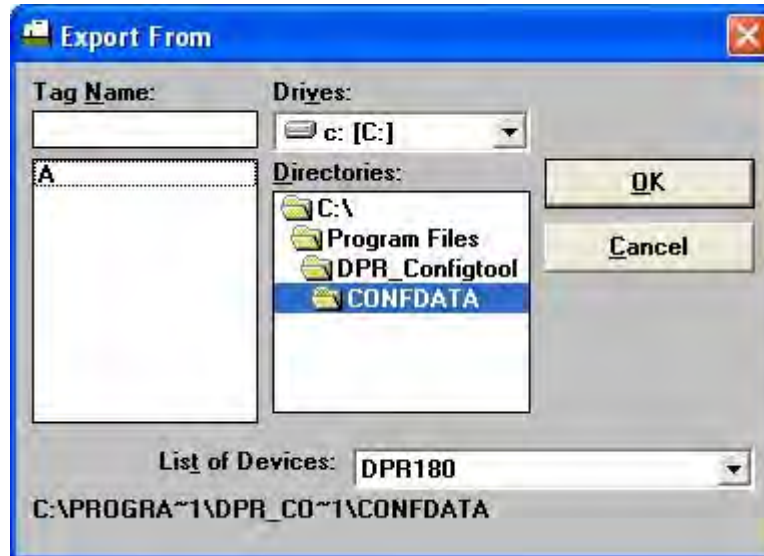

Select the database tag to be exported.

To copy one configuration on your drive, specify one of the configurations in your working directory and define the target file in the following dialog box.



The resultant file will be defined with an .exp extension and will only contain the configuration that has been exported.

## 5. PC CONFIGURATION

### 5.6.8 Import

Imports a configuration to the PC Configurator tool. This operation is mostly used during engineering where the configuration personnel uploads the configuration from one recorder, makes changes to parameters, and downloads the same to a set of recorders which need to function similarly.

The following dialog is displayed.

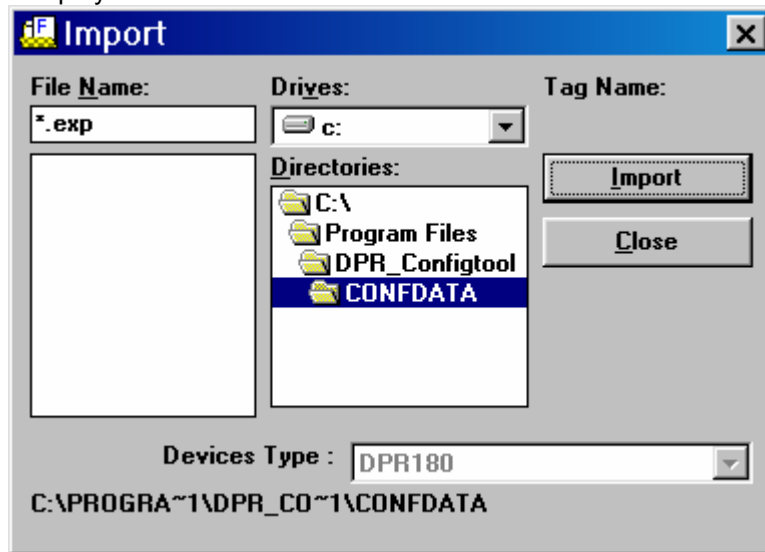

To open the previously exported configuration, select the .exp file containing your configuration. On completion of Import action, the configuration is opened.

### 5.6.9 Exit

Exits the program.

## 5.7 VIEW MENU

Click on the bars you want displayed.

- Toolbar
- View Status bar

See figure on page 5-6.

## 5.8 ON-LINE COMM MENU

### 5.8.1 Device

Select the device to be configured for communication.

### 5.8.2 Communication parameters

This dialog box displays the COM ports available on the system. Communication between the PC and the recorder can either be through the interface kit or by using RS232/ RS485 converter. If RS232/RS485 converter is used, communication with the recorder is through the comm board. Specify the address of the recorder.

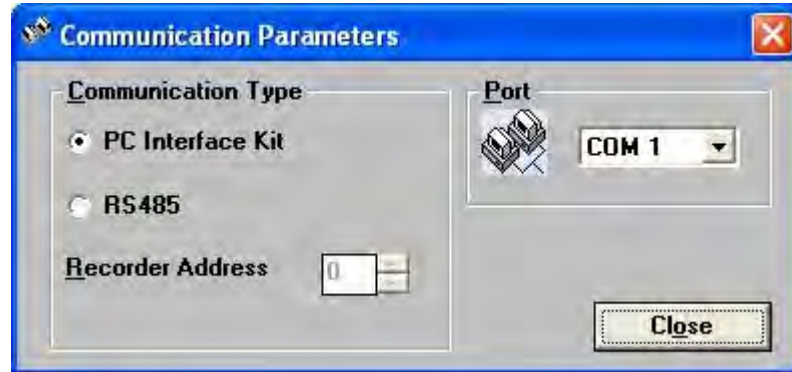

### 5.8.3 Upload configuration

Uploads the entire configuration from recorder to the PC. The confirmation dialog box below appears. Status (% completion) is shown during the upload process.

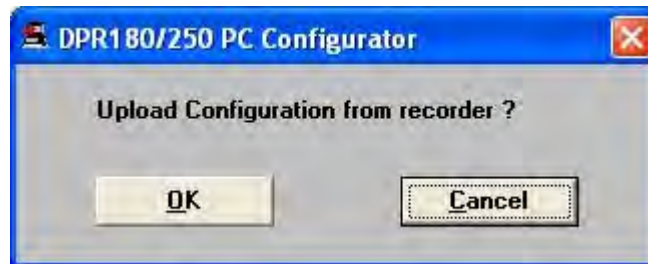



## 5. PC CONFIGURATION

---

### 5.8.4 Download configuration

Downloads configuration to a single recorder at a time. You can download part of the configuration by selection the required sub-matrices (as shown in below) or download the entire configuration by selecting All. Status (% completion) is shown during the download process. Error code appears if no communications with recorder. See section 5.13 ERROR MESSAGES.

Download button is also available on each matrix, with the same functionality. See figure on page 5-8.

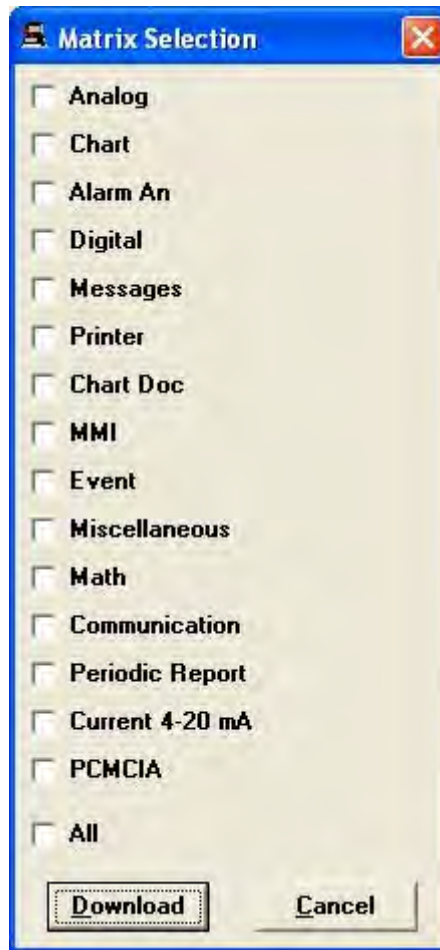



### 5.8.5 Upgrade Firmware: Firmware Files Installer

Installs earlier versions of the recorder firmware. In order to upgrade the firmware of the main board of the recorder or the communication board of the recorder, the firmware file has to be extracted from a .z file. Typically, Communication board firmware is named CBREC.Z and Main board firmware REC.Z. The extracted file would have a .rec extension.

Following are the steps followed to extract the firmware file.

1. Click on Device in the "On-Line Comm" menu to select the type of recorder.
2. Click on "Upgrade firmware" in the "On-Line comm" menu.
3. Click on "Firmware Files Installer". The following dialog appears.

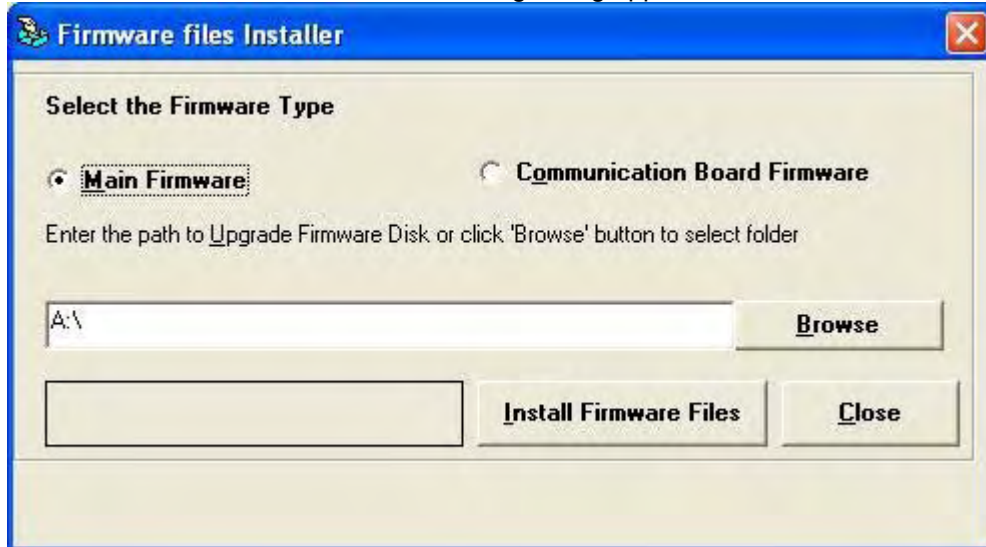

4. Click on the type of firmware file that is to be extracted.
5. Provide the location of the .Z file and click on "Install Firmware files".
6. The firmware file would be extracted to the installation directory of the tool.

## 5. PC CONFIGURATION

---

### 5.8.6 Upgrade Firmware: Main firmware

PC Configurator allows you to upgrade the main board firmware and the communication board firmware. Following are the steps to be followed to upgrade the firmware.

1. Click on Device in the "On-Line Comm" menu to select the type of recorder.
2. Click on "Upgrade firmware" in the "On-Line comm" menu.
3. Click on "Main Firmware".
4. Choose the ".rec" file containing the required firmware version that is to be sent to the recorder in the following dialog box.



5. Click on OK to send the firmware to the recorder. A dialog with the status bar for download would be displayed.
6. Click on Start button to start the download process.

## 5. PC CONFIGURATION

---

### 5.8.7 Upgrade Firmware: Communication firmware

To update the comm. firmware the following steps are followed

1. Click on Device in the "On-line Comm" menu to select the type of recorder
2. Click on "Upgrade Firmware" in the "On-line Comm" menu
3. Click on "Communication Firmware"

Choose the ".rec" file containing the required firmware version that is to be sent to the communication board in the following dialog box



5. Click on OK to send the firmware to the recorder. A dialog with the status bar for download would be displayed
6. Click on Start button to start the download process.

## 5. PC CONFIGURATION

### 5.8.8 Services

The window below is accessed by clicking on "Services" and "Relay Outputs State and Control" in the "On-Line Comm" menu. (DPR250 has more cards than the DPR180 shown below.)

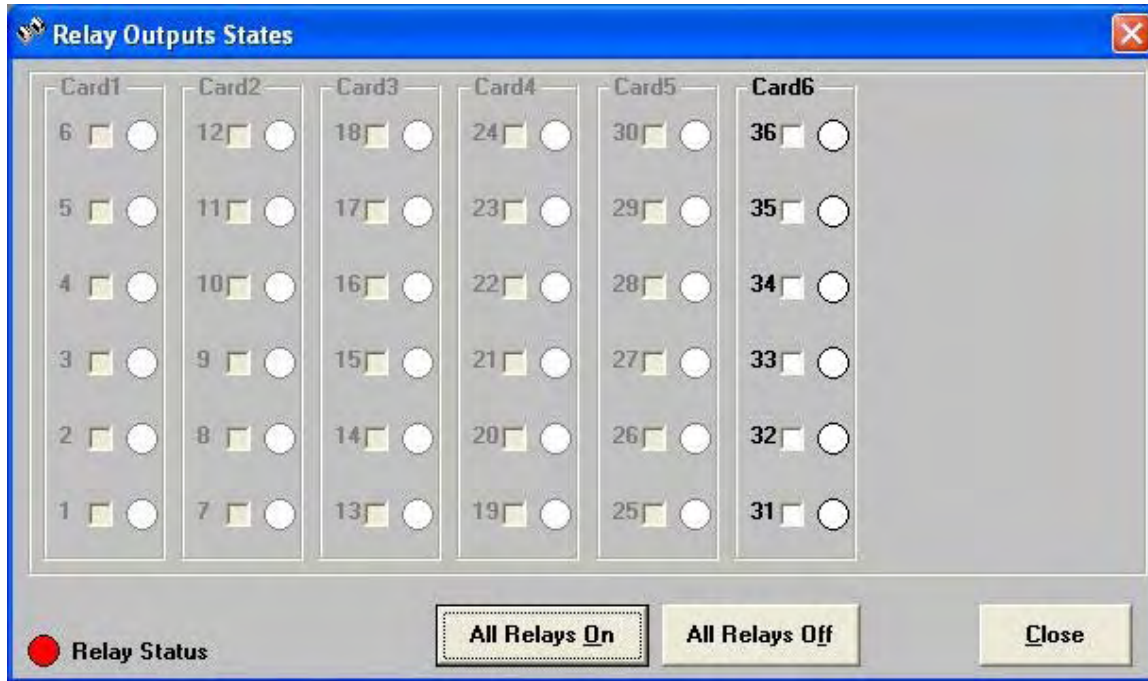

By pressing the "All Relays On" or "All Relays Off", button you can switch ON or OFF every relay on the recorder.

You can also switch ON or OFF one relay by clicking in the box as in the following example:

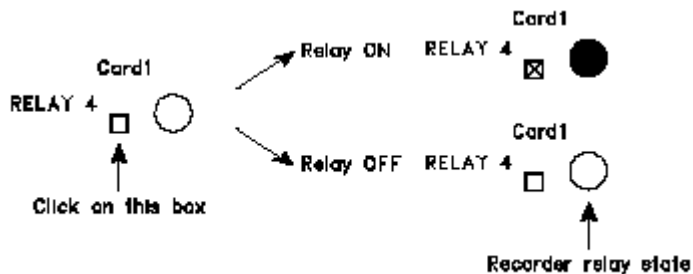

### 5.9 USER ACTUATION MENU

#### 5.9.1 Edit User Actuation File

The User Actuation function allows you to define a new sensor range that does not exist in the recorder. Each User Actuation is stored in a \*.ua file separated from the configuration files for easy exporting. Electrical measures can be matched with engineering units either by a set of segments or a set of polynomials. Thus, you must create a table defining segments. A User Actuation file (\*.fua) defined with polynomials can be established so that the sensor actuation will have the same accuracy as the recorder standard ranges.

	#1	#2	#3	#4	#5	#6	#7	#8	#9
<i>Elec. Value</i>									
<i>Eng. Value</i>									

	Temp.	Elec. Val.
<i>Lowest</i>	0	0
<i>Average</i>	30	30
<i>Highest</i>	60	60

To create a specific range of sensor:

1. Click on "User Actuation".
2. Click on "Edit User Actuation File" in the main menu to create a specific range of sensor.
3. Enter the actuation file name in the "File name" field
4. The "Sensor type" may be TC, RTD or SPECIAL.
5. The Description textbox is the range name of the sensor that will be displayed by the recorder, when reading the input range configuration.
6. The grid for electrical and engineering values represents the sensor actuation. Up to 50 pairs of points can be entered.
  - Electric unit: mV, V, mA or Ohm
  - Engineering unit: - for TC or RTD sensor: Deg C or Deg F
  - for SPECIAL sensor: to be entered
7. The "Cold Junction Correspondence" grid is for TC sensors only.
8. Click on "Check and Draw actuation" to check if data have been correctly entered.
9. Click on "OK" to close and save the actuation file or click on "Cancel" to abort changes and keep the previous data.

## 5. PC CONFIGURATION

### 5.9.2 Add User actuation to Configuration

To introduce a user actuation file into a recorder configuration, the following dialog box is used. This dialog box can be accessed by clicking on “Add User Actuation to configuration” menu item in the “User Actuation” menu

The dialog box titled "Adding User Actuation" contains the following elements:

- Header: "Adding User Actuation" with a close button (X).
- Instruction: "Select the files to associate to the user actuations :".
- Buttons: "OK", "Cancel", and "Edit" on the right side.
- Section 1: "User Actuation #1" (selected with a radio button).
  - Dropdown menu: "Not used".
  - Sensor: [Text input field]
  - Description: [Text input field]
- Section 2: "User Actuation #2" (not selected with a radio button).
  - Dropdown menu: "Not used".
  - Sensor: [Text input field]
  - Description: [Text input field]

Following are the steps used to introduce the user actuation file into the recorder configuration

1. Select the user actuation number i.e. either “User Actuation #1” or “User Actuation #2”
2. Select the User Actuation file you want to add to your configuration
3. Click on OK to save data and close the window
4. Click on Cancel to abort changes and keep the previous data
5. Click on Edit to display the selected User Actuation data window

## 5. PC CONFIGURATION

### 5.10 OPTIONS MENU

#### 5.10.1 Copy line

The copy line function can be used to copy the configuration details on one channel (source channel) to other channels (Destination channels). This option saves the effort required to configure a channel if a similar kind of monitoring is required on other channels. Following are the steps followed to execute the copy line operation.

1. Create a configuration for the selected DPR type.
2. Access the following dialog by choosing "Copy Line" option in the Options menu.

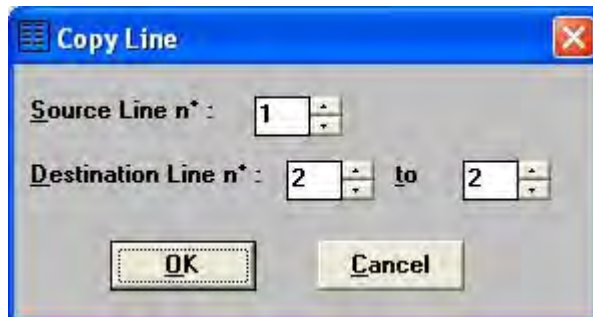

3. Specify the source line and a destination line or range of lines.

### 5.11 WINDOW MENU

Contains usual options Cascade, Tile, Arrange Icons. Shows names of all open configurations.

### 5.12 ABOUT

Provides the version information of the tool and the license information.

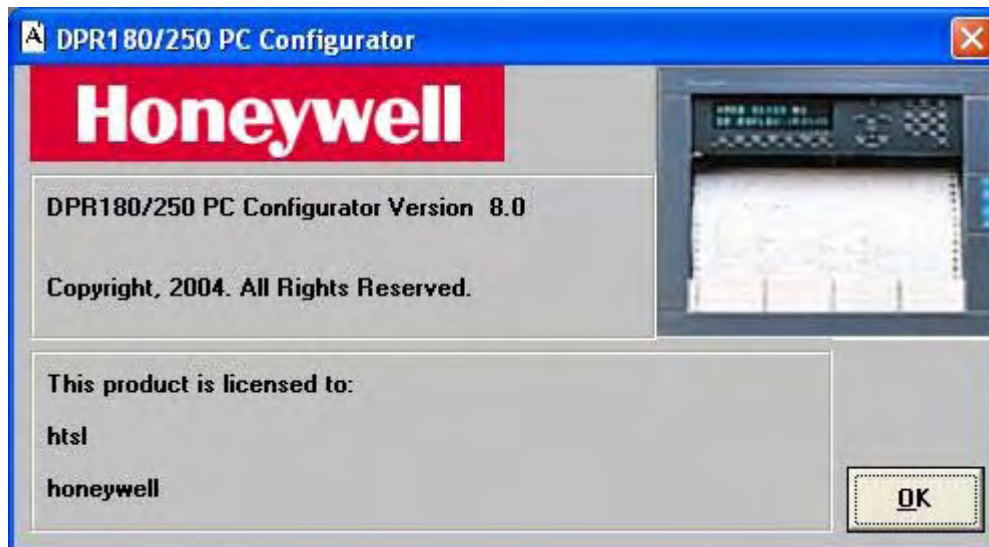

## 5. PC CONFIGURATION

### 5.13 ERROR MESSAGES

Messages are listed alphabetically.

Error message	Error Classification	Corrective action
An error occurred while loading Binary file	On opening an very old configuration file	The binary configuration file is generated by an old version (pre-7.2) of PC Configurator, which might not be supported by the current version.
An error occurred while saving Binary file	When an error occurs while saving the binary file	Retry the same operation. If it persists close the application and retry.
Bad device type selected	Communication error	Ensure that there is no mismatch between the device type selected through "On-Line comm.->Device menu", the configuration to be downloaded and the type of recorder (DPR 180/DPR 250) and retry the operation.
Checksum Error	Communication error	The protocol is not performing the reliable data transfer. Retry the operation. If the problem persists contact us for assistance.
Configuration is in use. Cannot remove configuration	Error during remove configuration operation	The configuration that the user is trying to remove is open in the PCConfigurator. Close the configuration and retry the operation.
Device locked	Communication error	Reset the power of recorder and retry the operation.
Device not available	Media in the drive does not exist	Floppy disk is not in the drive. Insert disk.
Device or DLL returned an unknown error. The Upgrade Firmware will be aborted	Firmware upgrade error	Close the application and retry the same operation.
Disk full.	Error during an export operation	Insert a floppy disk that has sufficient space to hold the exported configuration.
Disk not ready.	Error during an export operation	If there is no disk in the specified drive insert a disk and retry the operation. If the drive door of the specified drive is open, close the drive door and retry the operation.
End Upgrade Failed. The Upgrade Firmware will be aborted	Firmware upgrade error	The protocol did not provide a reliable date transfer. Retry the operation.
File already exists	Error during an export operation	This error occurs at run time when the new file name is identical to a file name that already exists. Specify a unique file name.
File is in use	Error when you try to overwrite a configuration file that is already in use	Close the configuration that is being overwritten from the PC Configurator and retry the operation.
Firmware file does not exist in	Error during firmware extraction	Ensure that ICOMp.exe and the firmware files (REC.Z for main firmware and CBREC.Z for communication board firmware) are in the location indicated.



## 5. PC CONFIGURATION

Error message	Error Classification	Corrective action
Folder contains invalid firmware files	Error during firmware extraction	Place the correct type and uncorrupted firmware files in the folder and retry the operation.
Hardware Error. The Upgrade Firmware will be aborted	Firmware upgrade error	A hardware error has been encountered. Contact us for assistance.
Invalid entry	Error message when values of parameters are not within valid range	The value of the parameter is outside its specified range. Enter a value that is within the range for the parameter.
Invalid path or file name	Error during firmware extraction	Check if a proper path is provided to the firmware file. To avoid typographical errors use the browse button to locate the folder containing the firmware files.
Invalid recorder address	Invalid recorder address is typed	Provide a recorder address which is within the 0-99 range.
No relay card present in the device!	Communication error	Insert a relay card into the recorder and retry the operation.
No Response received from Device	Communication error	Check connection between PC Configurator and recorder. Check that correct recorder type is selected.
Printer not available	Error on non-availability of printer	Check if the printer is connected and configured properly before issuing a print command.
Protocol Error	Communication error	Reset the power of recorder and retry the operation.
Protocol Error. The Upgrade Firmware will be aborted	Firmware upgrade error	A wrong protocol was used for firmware upgrade. Re-install the PC Configurator and try again.
Ram Write Error. The Upgrade Firmware will be aborted	Firmware upgrade error	A wrong protocol was used for firmware upgrade. Re-install the PC Configurator and try again.
Tag not found	Open configuration	Provide a tag name from the displayed list of tag names during an open operation
The disk is not formatted.	Error during an export operation	Format the floppy disk and retry the operation.
The second destination line must be superior at the first.	Error during an Copy Line operation	"To" value must be greater than "Destination Line n" value.
The selected file is not valid for Upgrade Firmware. The Upgrade Firmware will be aborted	Firmware upgrade error	Chose the correct file for firmware upgrade. (001XX.REC for main firmware upgrade and 100XX.REC for communication firmware upgrade)
There are unconformities in: line:	Unconformity	Unconformities between the hardware options and the configuration being downloaded.
Unable to create firmware file	Error during firmware extraction	Close the application and retry.

## 5. PC CONFIGURATION

---

<b>Error message</b>	<b>Error Classification</b>	<b>Corrective action</b>
Unable to remove configuration	Error during remove configuration operation	Provide a non-corrupted database that contains the configurations and retry the operation.
Unexpected Reset of Device. The Upgrade Firmware will be aborted	Firmware upgrade error	The device has reset during the download. Retry the operation
Upgrade failed	Firmware upgrade error	Upgrade operation was not completed. The reason for error is displayed prior to "Upgrade failed" error message.
Verify that the disk is not protected and retry the action.	Error during an export operation	Ensure that the tab on the floppy disk is set to a position that allows data to be written onto the disk and retry the operation.
Warning: Configuration corrupted!	Corruption of configuration	Delete the selected configuration file and recreate the configuration file.

## 6. KITS LIST

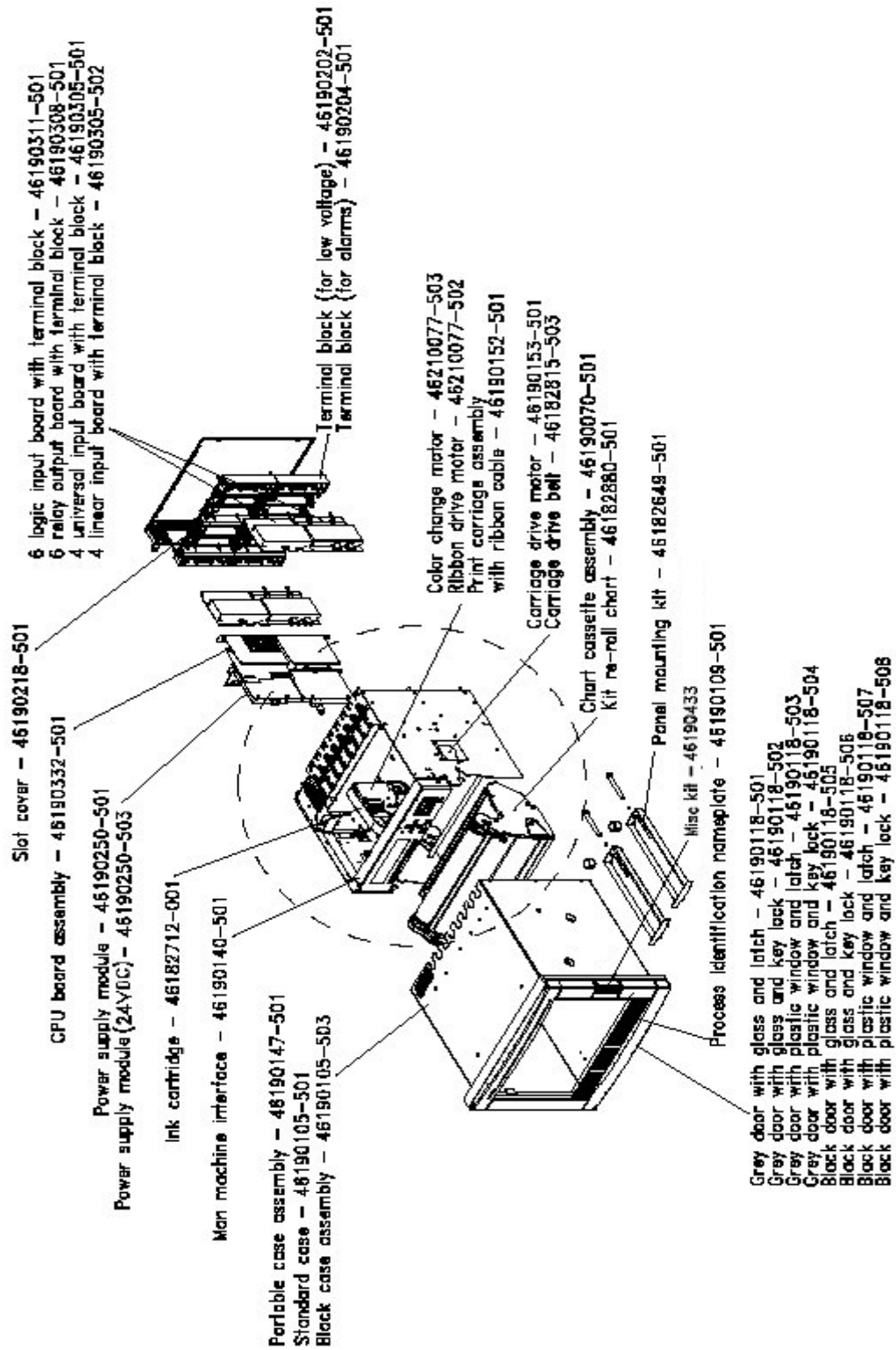

## 6. KITS LIST

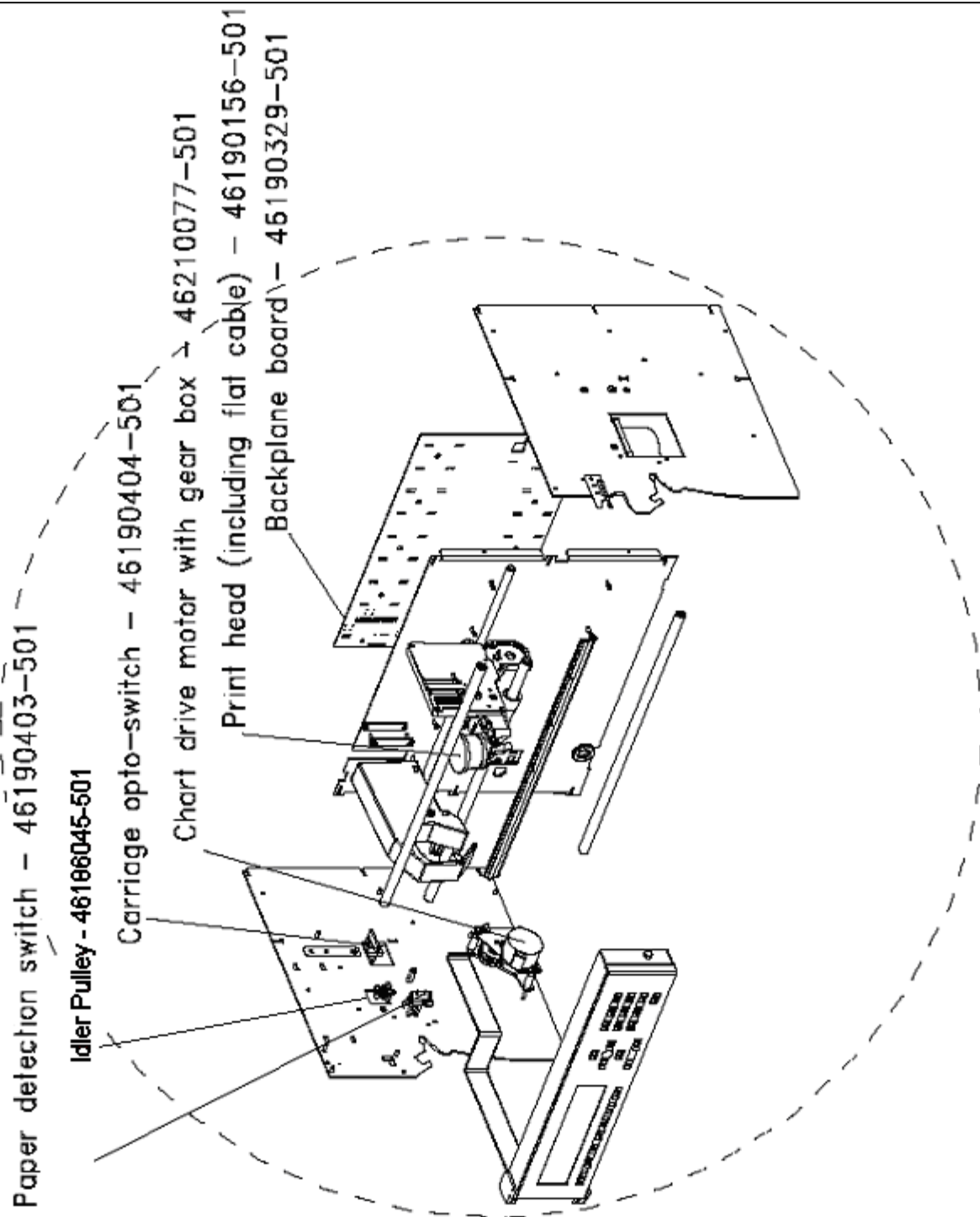

## 6. KITS LIST

KITS LIST	PART #
<b>ELECTRONICS/SOFTWARE</b>	
Man machine interface	46190140-501
Power supply module (AC power)	46190250-501
Power supply module (24VDC)	46190250-503
CPU board assembly	46190332-501
Backplane board	46190329-501
Analog output board kit	46190314-501
PCMCIA upgrade kit	46190163-501
PCMCIA to FLASH adapter	50001014-501
512MB Compact Flash card	50001011-505
1.0GB Compact Flash card	50001011-506
6 logical input board with terminal block	46190311-501
Universal input board with terminal block	46190305-501
Linear input board with terminal block	46190305-502
6 relays output board with terminal block	46190308-501
Ethernet Interface Card	51500651-501
RS232/422/485 Communications Board Kit	46190260-501
TrendManager Pro (Data Analysis) software (single)	50016133-501

KITS LIST	PART #
<b>MECHANICAL PARTS</b>	
<b>Print head, motors and belts</b>	
Chart cassette assembly	46190070-501
Chart cassette tension belt	46182835-001
Chart Cassette Side Plate kit	46182900-501
Print head (including flat cable)	46190156-501
Intercabling board w/ribbon cable	46186645-502
Color change motor	46210077-503
Ribbon drive motor	46210077-502
Carriage drive motor	46190153-501
Chart drive motor with gear box	46210077-501
Carriage gear kit	46182899-501
Carriage drive belt	46182815-503
Idler Pulley	46186045-501
Print carriage assembly with Rod w/o Print head	46190152-503
Print carriage assembly w/o Print head & Rod	46190152-501
Display cable	46190132-501
Kit re-roll chart-takeup spool complete	46182880-501
Grey door with glass and latch	46190118-501
Grey door with glass and key lock	46190118-502
Grey door with plastic window and latch	46190118-503
Grey door with plastic window and key lock	46190118-504
Black door with glass and latch	46190118-505
Black door with glass and key lock	46190118-506
Black door with plastic window and latch	46190118-507
Black door with plastic window and key lock	46190118-508
Process identification nameplate	46190109-501
Portable case assembly	46190147-501
Painted black case	46190105-503

## 6. KITS LIST

KITS LIST	PART #
<b>COMMUNICATION PARTS</b>	
PC Configurator interface with cables and diskette	46187121-501
PC Configurator and Firmware CD	46190407-501
Kit Maths upgrade package	46190424-501
Cable for Comm. link to PC	46210098-501
Communication upgrade kit (board and manual)	46190416-501
Programming Cable from PC Configuration Tool to Recorder	46188684-502
<b>MISCELLANEOUS</b>	
Fluorescent tube for chart illumination	46190406-501
Terminal block (for low voltage)	46190202-501
Terminal block (for alarms)	46190204-501
Paper detection switch	46190403-501
Carriage opto-switch	46190404-501
Battery	46222201-502
Slot cover	46190218-501
Panel mounting kit	46182649-501
Rubber grommets	46173047-510
Kit chart platen	46190160-501
Re-roll Tube (empty chart tube only)	46171079-004
Packaging box for transport	46190420-001
Tools kit	46190410-501
Mounting adaptor plate 20.11"x 14.88" (511mm x 378mm)	30756326-001
Mounting adaptor plate 19.0"x 13.2" (483mm x 335mm)	30756305-001
Rack Mounting Kit	46182883-001
Kit of grease for Print Carriage	46210096-501
Miscellaneous Hardware kit (Incl. fuses, labels, grommets, door hinge pins, assort screws, 2 keys for keylock)	46190433-501
<b>CONSUMABLES</b>	
Chart roll 100 divisions (35 meters)	46182708-001
Fan fold chart 100 divisions (35 meters)	46182707-001
Ink cartridge	46182712-001
4 resistors 250 Ohms each for mA input	46181080-503
Fuse 100 to 230 V ac/dc (Europe STD: 5 x 20 mm)	46182886-502
Fuse 100 to 230 V ac/dc (US STD: 5 x 32 mm)	46182886-501
<b>DOCUMENTATION</b>	
DPR180 Product manual	US1I-6171
DPR250 Product manual	US1I-6199
DPR180/250 Maths option manual	EN1I-6184
DPR180/250 Communication option manual	US1I-6189
DPR180/250 PCMCIA option manual	US1I-6208
Ethernet Interface manual	51-52-25-96

# 7. TROUBLESHOOTING

---

## TABLE OF CONTENTS

Section	Page
7.1	PARTS LOCATION ..... 7-2
7.2	SYMPTOM: UNIT DOES NOT RESPOND TO POWER UP ..... 7-4
7.3	SYMPTOM: NO DISPLAY BUT THE PRINTING WORKS PROPERLY ..... 7-4
7.4	SYMPTOM: THE CHART ILLUMINATION FAILED ..... 7-4
7.5	SYMPTOM: DISPLAY SHOWS ONLY ALL DOTS LIGHT OR INCOHERENT DISPLAY ..... 7-4
7.6	SYMPTOM: DISPLAY SHOWS: BATTERY FAILED ..... 7-5
7.7	SYMPTOM: DISPLAY SHOWS: EEPROM FAILED ON CPU BOARD ..... 7-5
7.8	SYMPTOM: DISPLAY SHOWS: EEPROM FAILED ON BACKPLANE BOARD ..... 7-5
7.9	SYMPTOM: DISPLAY SHOWS: EEPROM FAILED ON SLOT # ..... 7-5
7.10	SYMPTOM: DISPLAY SHOWS: RAM BAD ..... 7-5
7.11	SYMPTOM: DISPLAY SHOWS: REAL TIME CLOCK PROGRAMMING FAILED ..... 7-5
7.12	SYMPTOM: DISPLAY SHOWS: DATE & TIME NEED READJUSTMENT ..... 7-6
7.13	SYMPTOM: DISPLAY SHOWS: BAD CARRIAGE DIS. .... 7-6
7.14	SYMPTOM: ANALOG INPUTS OUTSIDE SPECIFIED ACCURACY TOLERANCE ..... 7-6
7.15	SYMPTOM: NO COMMUNICATION WITH PC CONFIGURATOR ..... 7-7
7.16	SYMPTOM: THE ALARM FEATURE DOES NOT WORK PROPERLY ..... 7-7
7.17	SYMPTOM: PRINTER INOPERATIVE ..... 7-8
7.18	SYMPTOM: ADVANCE PAPER INOPERATIVE ..... 7-8
7.19	SYMPTOM: CARRIAGE INOPERATIVE ..... 7-8
7.20	SYMPTOM: PRINT HEAD INOPERATIVE ..... 7-9
7.21	SYMPTOM: INCORRECT COLOR ..... 7-9
7.22	SYMPTOM: INCORRECT PRINT OUT ..... 7-9
7.23	SYMPTOM: DOUBLE TRACE ON THE CHART PAPER ..... 7-9
7.24	ERROR MESSAGES ..... 7-10

# 7. TROUBLESHOOTING

## 7.1 PARTS LOCATION

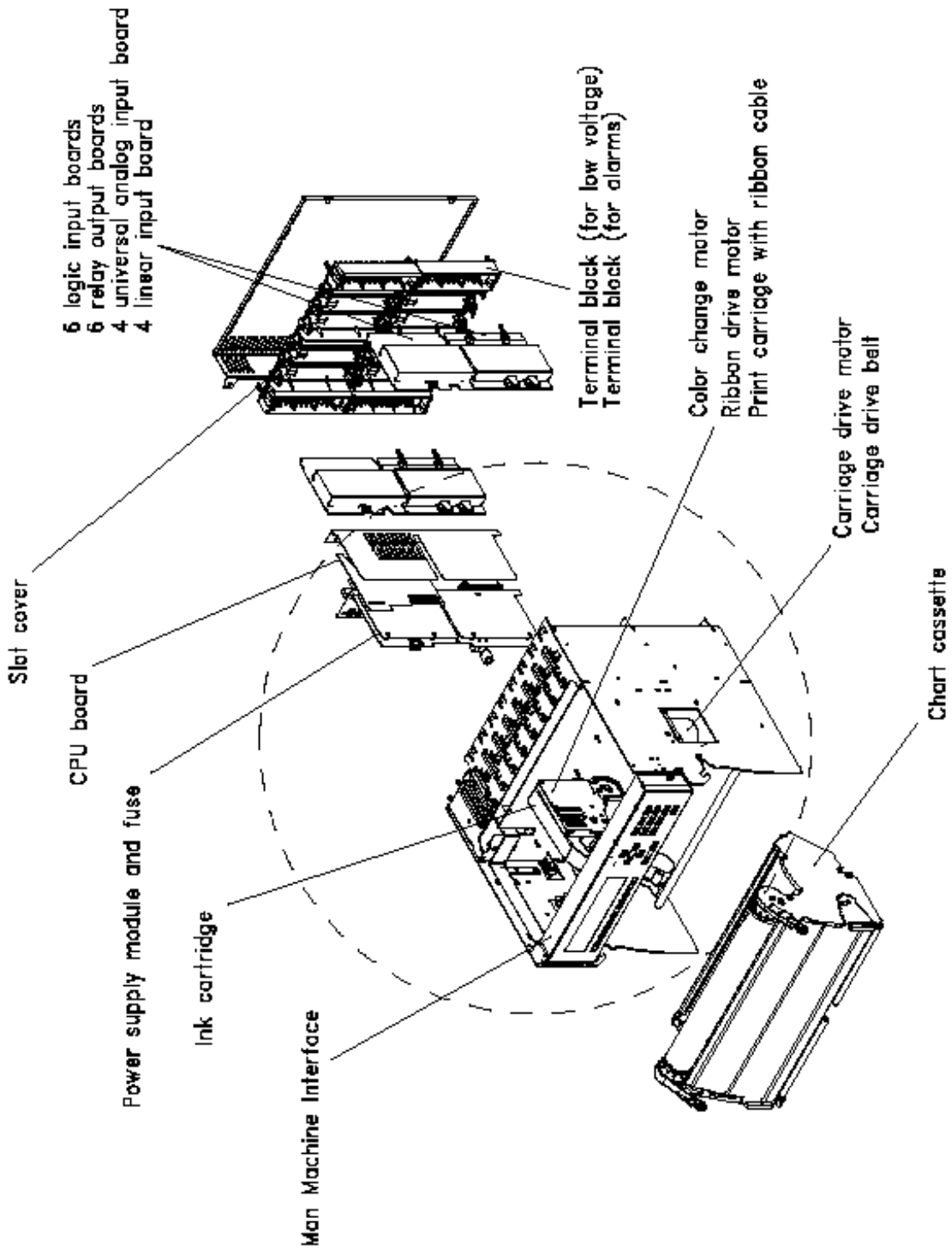



# 7. TROUBLESHOOTING

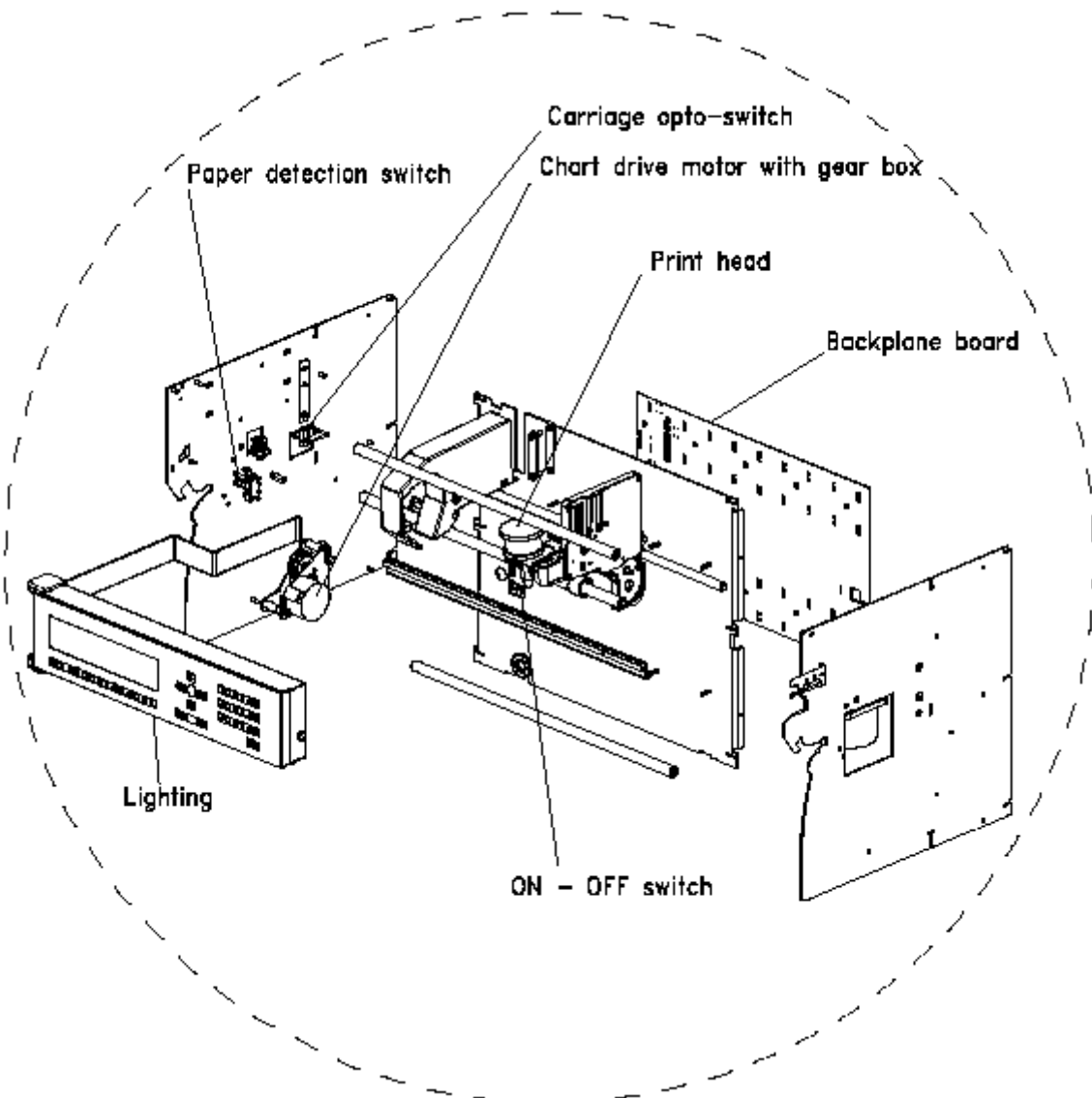

## 7. TROUBLESHOOTING

---

### 7.2 SYMPTOM: UNIT DOES NOT RESPOND TO POWER UP

<i>CHECK</i>	<i>DIAGNOSTIC / ACTION</i>
1. Check if the power switch is on.	1. <b>NO:</b> Push the switch on.
2. Check the voltage applied to the supply terminals L1 and L2. Is there loss of line power?	2. <b>YES:</b> Check wiring.
3. Check if the fuse is OK.	3. <b>NO:</b> Change the fuse
4. Is the fluorescent light working?	4. <b>NO:</b> Replace the power supply.
5. Is the problem still present with a new power supply or with lightning fluorescent tube.	5. <b>YES:</b> Replace the CPU board.

### 7.3 SYMPTOM: NO DISPLAY BUT THE PRINTING WORKS PROPERLY

<i>CHECK</i>	<i>DIAGNOSTIC / ACTION</i>
1. Check if the flat cable connection between MMI and CPU board is correct.	1. <b>NO:</b> Check for the proper connection.
	2. Change the MMI.

### 7.4 SYMPTOM: THE CHART ILLUMINATION FAILED

<i>CHECK</i>	<i>DIAGNOSTIC / ACTION</i>
1. Fluorescent tube out?	1. <b>YES:</b> Replace the fluorescent tube.
2. Is the printer operative?	2. <b>NO:</b> Replace power supply.
3. If still not correct	3. Replace the MMI.

### 7.5 SYMPTOM: DISPLAY SHOWS ONLY ALL DOTS LIGHT OR INCOHERENT DISPLAY

<i>CHECK</i>	<i>DIAGNOSTIC / ACTION</i>
1. Check if the flat cable connection between MMI and CPU board is correct.	1. <b>NO:</b> Check for the proper connection.
	2. Change the CPU board.
	3. Change the MMI.

## **7. TROUBLESHOOTING**

---

### **7.6 SYMPTOM: DISPLAY SHOWS: BATTERY FAILED**

**CHECK**

**DIAGNOSTIC / ACTION**

1. Change the battery.

### **7.7 SYMPTOM: DISPLAY SHOWS: EEPROM FAILED ON CPU BOARD**

**CHECK**

**DIAGNOSTIC / ACTION**

1. Change the CPU board.

### **7.8 SYMPTOM: DISPLAY SHOWS: EEPROM FAILED ON BACKPLANE BOARD**

**CHECK**

**DIAGNOSTIC / ACTION**

1. Change the backplane board.

### **7.9 SYMPTOM: DISPLAY SHOWS: EEPROM FAILED ON SLOT #**

**CHECK**

**DIAGNOSTIC / ACTION**

1. Change the board in slot #.

### **7.10 SYMPTOM: DISPLAY SHOWS: RAM BAD**

**CHECK**

**DIAGNOSTIC / ACTION**

1. Change the CPU board.

### **7.11 SYMPTOM: DISPLAY SHOWS: REAL TIME CLOCK PROGRAMMING FAILED**

**CHECK**

**DIAGNOSTIC / ACTION**

1. Change the CPU board.

## 7. TROUBLESHOOTING

---

### 7.12 SYMPTOM: DISPLAY SHOWS: DATE & TIME NEED RE-ADJUSTMENT

#### CHECK

1. Check time and date.
2. Does it solve?
3. Does it solve?

#### DIAGNOSTIC / ACTION

1. Readjust time and date.
2. Change the battery.
3. Change the CPU board.

### 7.13 SYMPTOM: DISPLAY SHOWS: BAD CARRIAGE DIS

#### CHECK

#### DIAGNOSTIC / ACTION

1. Remove the chart cassette.
2. Push the switch off.
3. Push the switch on.
4. Re-insert the chart cassette.

### 7.14 SYMPTOM: ANALOG INPUTS OUTSIDE SPECIFIED ACCURACY TOLERANCE

#### CHECK

#### DIAGNOSTIC / ACTION

- |   |   |
|---|---|
| 1. Is the range configuration for every sensor?                         | 1. <b>NO:</b> Reconfigure the frequency.  |
| 2. Is the recorder configured for the correct supply frequency?         | 2. <b>NO:</b> Reconfigure the frequency   |
| 3. Check the sensors, leads and input terminals. Are the contacts good? | 3. <b>NO:</b> Reconnect properly sensors, leads, input terminals.   |
| 4. Are the environmental conditions outside rated limits?               | 4. <b>NO:</b> Ensure that ambient temperature and relative humidity are within limits. Be sure delay has been long enough since power on. |
| 5. Does it solve?   | 5. <b>NO:</b> Replace the appropriate analog input card.  |
|   | 6. Replace the backplane board.   |

# 7. TROUBLESHOOTING

---

## 7.15 SYMPTOM: NO COMMUNICATION WITH PC CONFIGURATOR

### CHECK

1. Is the PC showing "NO RESPONSE FROM DEVICE"?
2. Is the PC showing "ERROR MESSAGE RECEIVED FROM DEVICE" or "BAD DEVICE TYPE SELECTED" ?
3. Test the PC Configurator with other recorders, test the recorder with another PC Configurator.

### DIAGNOSTIC / ACTION

1. Check that INTERFACE parameter equals to JACK in MISCELLANEOUS matrix. Wait until end of initialization.  
Check wiring.  
Verify the selected product in PC software.  
Verify the recorder version. If the version of your recorder Firmware is previous than 001AC (001AB and 001AA), you must upgrade the new Firmware.
2. The type of device is incorrectly selected. Click on "Device" in the "Online Comm" menu and select the right type of device you want to communicate with.
3. Send back the faulty product to your nearest Service Center.

## 7.16 SYMPTOM: THE ALARM FEATURE DOES NOT WORK PROPERLY

### CHECK

1. Check the jumper selection on relay board. Is it correct?
2. Check the "relay" parameter in the alarm matrix. Is it correct?
3. Are the connectors correctly fitted?
4. If still not correct
5. If still not correct

### DIAGNOSTIC / ACTION

1. **NO:** Reconfigure.
2. **NO:** Reconfigure.
3. **NO:** Reconnect.
4. Replace the alarm board.
5. Return the faulty product to your nearest Service Center.

## 7. TROUBLESHOOTING

---

### 7.17 SYMPTOM: PRINTER INOPERATIVE

#### CHECK

1. Is the fluorescent tube on?
2. Check the configuration: is there anything wrong?
3. Is the chart correctly installed in the chart cassette?
4. Is the chart damaged?
5. Is the chart cassette engaged in the chassis?
6. Remove the chart cassette and push the paper detection switch on the left side. Do you see the paper advance gear turning, carriage, color and ribbon moving?
7. Is carriage always going left or always going right?

#### DIAGNOSTIC / ACTION

1. **NO:** Replace the power supply (same voltage for light and motors).
2. **YES:** Reconfigure. Print inhibit with digital input ("ACTION" parameter) Print inhibit with alarm ("ACTION" parameter) Check speed 1 and speed 2.
3. **NO:** Install the chart correctly.
4. **YES:** Advance chart beyond damaged section
5. **NO:** Insert the chart cassette into the chassis properly.
6. **YES:** Check point above.  
Check if paper switch deformed.  
Check if chart cassette damaged.  
**NO:** Verify power supply (light).  
Verify paper switch connection on the backplane board.  
Replace paper switch.  
Check CPU board.
7. **YES:** Check opto sensor connections.

### 7.18 SYMPTOM: ADVANCE PAPER INOPERATIVE

#### CHECK

1. Only chart still not functioning

#### DIAGNOSTIC / ACTION

1. Check motor connection on backplane board.  
Check motor about 80  $\Omega$  per coil.  
Check gear box.  
Check cassette gear.  
If not, replace CPU board.

### 7.19 SYMPTOM: CARRIAGE INOPERATIVE

#### CHECK

1. Is the belt correctly installed?
2. Is the carriage motor properly connected on backplane board?
3. Is the motor coil about 7  $\Omega$  per coil?
4. Is the pulley free to rotate?
5. If the problem still present

#### DIAGNOSTIC / ACTION

1. **NO:** Reinstall belt.
2. **NO:** Reconnect the motor.
3. **NO:** Change motor.
4. **NO:** Change pulley.
5. Check backplane board.  
Check CPU board.

## 7. TROUBLESHOOTING

---

### 7.20 SYMPTOM: PRINT HEAD INOPERATIVE

#### CHECK

1. Is cartridge missing?
2. Is cartridge well engage ?
3. Is print head well connected?
4. Check print head coils \*
5. If the problem remains

#### DIAGNOSTIC / ACTION

1. **YES:** Install cartridge.
2. **NO:** Install cartridge and push it on fully.
3. **NO:** Reconnect the flat cable on the CPU board.
4. **NO:** Change print head.
5. Change CPU board.

\* With reference on the first top pin of the flat cable you should measure:

50  $\Omega$ , 25  $\Omega$ , 50  $\Omega$ , 50  $\Omega$ , 50  $\Omega$ , 50  $\Omega$ , 25  $\Omega$ , Open circuit, 50  $\Omega$

### 7.21 SYMPTOM: INCORRECT COLOR

#### CHECK

1. Is cartridge installed?
2. Is color motor properly connected?
3. Is the motor coil about 80  $\Omega$  per coil?
4. Is the color always black?

#### DIAGNOSTIC / ACTION

1. **NO:** Install cartridge and push it fully.
2. **NO:** Reconnect the flat cable on the CPU board.
3. **NO:** Change motor.
4. **YES:** Check printing delay (speed too high or printer left with no paper) make correction and cycle power to recorder.

### 7.22 SYMPTOM: INCORRECT PRINT OUT

#### CHECK

1. Is printing too light?
2. Are some colors missing?
3. Is printing trace unstable?

#### DIAGNOSTIC / ACTION

1. **YES:** Check cartridge ribbon (too old).  
Check gap print head (0.6 mm, 0.0236").  
Check motor ribbon (about 80  $\Omega$  per coil).
2. **YES:** Check color calibration.  
Clean color mechanism.
3. **YES:** Check 0% and 100% paper calibration.  
Clean carriage driving bar.

### 7.23 SYMPTOM: DOUBLE TRACE ON THE CHART PAPER

#### CHECK

1. Check if the carriage belt is worn where the carriage is fixed on the belt.

#### DIAGNOSTIC / ACTION

1. If the belt is worn, free the belt from the carriage.
2. Move the carriage some centimeters right or left, on a non-worn part of the belt.
3. Put the belt back on the carriage.

## 7. TROUBLESHOOTING

---

### 7.24 ERROR MESSAGES

#### **NO TRACE**

Display is selected for traces but no traces are configured in the chart configuration on each channel

#### **NO PAPER**

No paper in the cassette has activated the "Paper Out" switch or the cassette has been removed

#### **END PAPER**

The Chart Length counter has reached 0

#### **BATTERY FAIL**

The Lithium Battery for the Real Time Clock is at the level less than 3V

#### **ONE ALARM ON**

The configured Alarm/Event has occurred

#### **BURNOUT**

The input is configured and in a Burnout Condition or an input in burnout has disabled

#### **SHEDTIME**

The configured time period within which the communications response has not occurred

#### **PRT INHIBIT**

All print actions have been inhibited

#### **OVERFLOW SPEED**

The print buffer is near its capacity, filling the printer requirements with alarm messages, chart documentation information. Buffer will fill if paper is not installed. Remove power and install chart paper.

#### **EV PRECURSOR**

Event precursor mode is enabled and the recorder is in standby

#### **TEST PASSED**

The recorder passes the self-test (diagnostic and running-in test)

#### **TEST FAILED**

The recorder fails the self-test (either diagnosis or running-in test)

#### **NO RESPONSE**

There is no communication between the recorder and the PCconfigurator

#### **BAD CARRIAGE DISPLACEMENT**

The carriage movement requires more steps to reach the "zero reference" than the processor expects

#### **BAD REFERENCE**

Zero reference sensor bad or not connected



## 7. TROUBLESHOOTING

---

### **BAD COLD JUNCTION REFERENCE**

Bad reading coming from Cold Junction Reference Resistor

### **PCMCIA BAD**

Some data could not have been stored on PCMCIA card because of a physical problem on it

### **PCMCIA NOT INIT**

PCMCIA card has been recognized but not initialized

### **PCMCIA PENDING**

Data can not be stored on the PCMCIA card because the configuration stored on it does not match the recorder configuration or there is no memory card

### **PCMCIA CONF CHG**

There is a difference between the configuration of the recorder and the parameters stored in the memory card, the parameters may be one of the following: the ID number, the language, the trace, the destination, the tagname and the engineering unit.

### **PCMCIA DATA LOST**

This message is displayed if data written on the PCMCIA card has not been stored and has been removed from the internal buffer.

### **PCMCIA FULL**

One of the PCMCIA files is nearly full according to the EVENT definition

### **PCMCIA MISSING**

There is no PCMCIA card inside the recorder or the card has not been detected

### **CARD PRESENT**

A PCMCIA card is present with no problem detected

### **BAD EEPROM BACKPLANE**

EEPROM not responding

### **BAD EEPROM INPUT**

EEPROM not responding

## **7. TROUBLESHOOTING**

---

### TABLE OF CONTENTS

Section	Page
8.1 OPERATOR INTERFACE .....	8-2
8.1.1 ACCESS TO SERVICE .....	8-2
8.1.2 PASSWORDS .....	8-2
8.1.3 ACCESS TO FUNCTIONS DURING SERVICE .....	8-4
8.2 LIST OF SERVICES .....	8-5

### 8.1 OPERATOR INTERFACE

#### 8.1.1 ACCESS TO SERVICE

Access to **READ/WRITE** Configuration, **COPY**, **PRINT CONFIG**uration or **SERVICE** from Operation mode is obtained by pressing the **SETUP** key.

#### 8.1.2 PASSWORDS

To protect the recorder against unauthorized access, the operator has to enter a password. There are two possible levels of access :

- Password #1 allows reduced access to service. If password #1 is used, you are only able to adjust the 0 % and 100 % chart markings.
- Password #2 allows full access to service.

**NOTE:** Use of the ▲ ▼ keys allows you to select **SERVICE**.

## 8. SERVICE

Use of the ◀ ▶ keys allows you to select one of the following functions of parameters for **SERVICE** action:

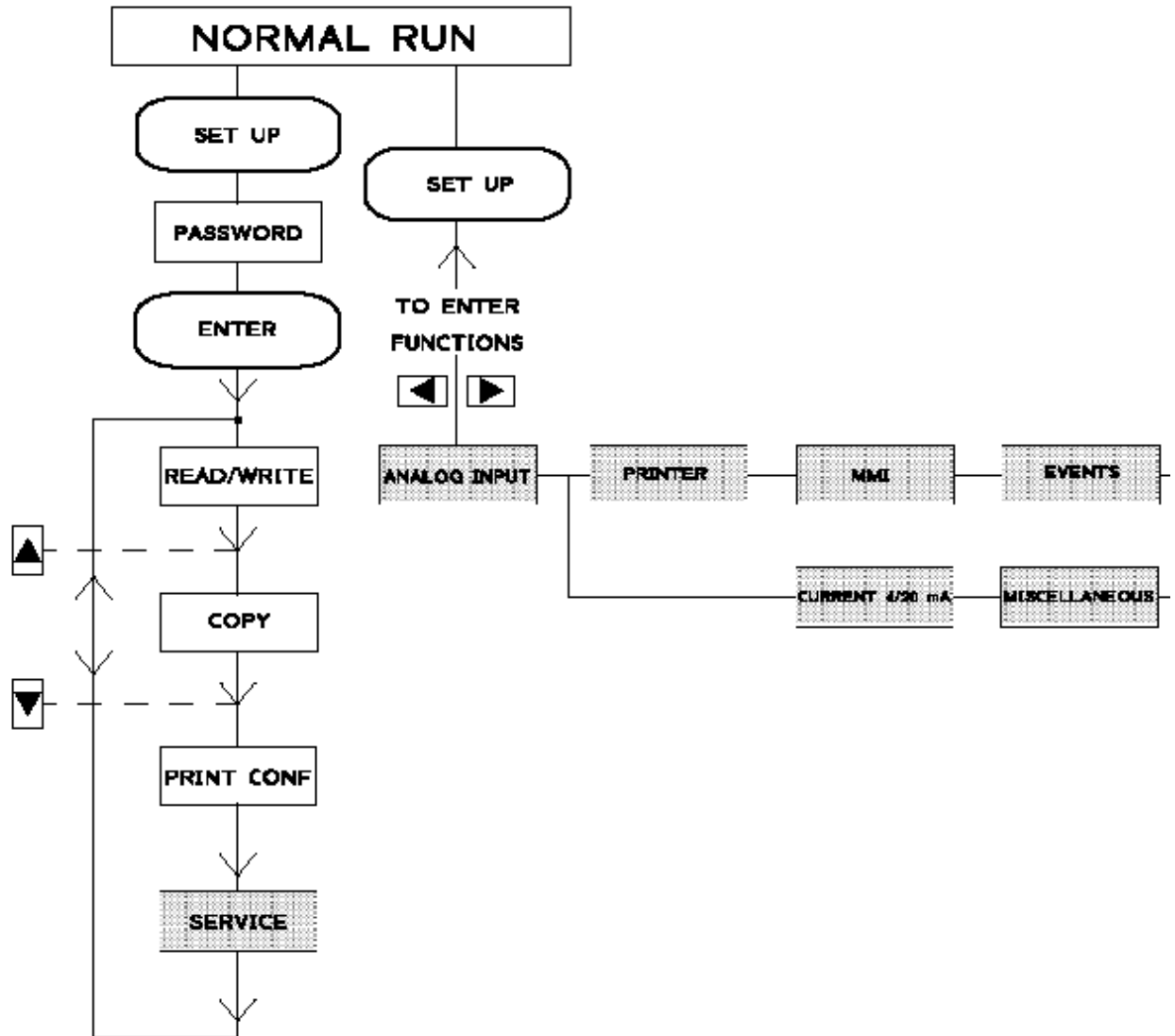

Press **ENTER** to validate your selection, or press **SETUP** to come back to main function.

### 8.1.3 ACCESS TO FUNCTIONS DURING SERVICE

TYPES OF SERVICE SELECTION:

The ◀ ▶ keys allows you to select the type of service you want to execute.

The ▲ ▼ keys allows you to select the channel on which you want to execute the service.

Press **ENTER** to validate your selection, or press **SETUP** to come back to main function.

<i>SUB-MATRIX</i>	<i>PARAMETER</i>	<i>CLASSIFICATION</i>
<b>NAME OF THE FUNCTION</b>	<b>NAME OF THE PARAMETER</b>	<b>IMPORTANCE OF THE PARAMETER</b> ◆ CAN BE CHANGED IN RUN MODE ◆◆ STOP OF ACQUISITIONS ▣ WITH PASSWORD 1 OR 2 ▣▣ ONLY WITH PASSWORD 2

**DEFINITION:** EXPLAIN THE ROLE OF THE PARAMETER

**HOW TO MODIFY IT:** BY SELECTING OR ENTERING A NEW VALUE I.E. USING THE ▼ ▲ KEYS

**POSSIBLE VALUES:** LIST OF POSSIBLE VALUES OR LIMITS

**SEE ALSO:**

**EXAMPLE:**

**NOTE:**

## NOTICE

The configuration of parameters with the classification “◆◆” stops the acquisition as well as the operation of alarm supervision. Leaving the configuration mode resets the memory buffer and the alarm status is defined again, and the chart speed changes back to the configured value. Occurrence value is reset.

**8.2 LIST OF SERVICES**

<b>➔</b>	<b>ANALOG INPUT</b>	page 8-5
<b>➔</b>	<b>PRINTER</b>	page 8-10
<b>➔</b>	<b>MMI</b>	page 8-18
<b>➔</b>	<b>EVENTS</b>	page 8-19
<b>➔</b>	<b>MISCELLANEOUS</b>	page 8-20
<b>➔</b>	<b>CURRENT 4/20 mA</b>	page 8-24

**SUB – MATRIX**                      **ANALOG INPUT**

<b>PARAMETERS</b>	<b>PV CALIB</b>	page 8-6
	<b>CAL DATE</b>	page 8-8
	<b>JUNCT °C</b>	page 8-8
	<b>JUNCT T°</b>	page 8-9

SUB-MATRIX	PARAMETER	CLASSIFICATION
<b>ANALOG INPUT</b>	<b>PV CALIB</b>	◆◆ □□
<b>DEFINITION:</b>	Allows the user to calibrate the 0% and 100% of the measure system.	
<b>HOW TO MODIFY IT:</b>	Allows the user to calibrate the 0% and 100% of the measure system. The message "1 (channel) <b>CAL 0%</b> " is flashing with " <b>CONNECT 0%</b> ". (Asks the user to prepare the system for the 0% calibration). Set input generator to deliver a signal corresponding to low scale (0%).	
	<b>NOTE:</b> For some thermocouples, the accuracy is inherently low . For these thermocouples, the " <b>CAL 0%</b> " (low point) has been shifted to the values listed below:	
	<b>Thermocouple CAL 0%</b> PR20-40    1100°C = 2012°F B            600°C = 1112°F WW26      400°C = 752°F	
	Then press <b>ENTER</b> , calibration starts and " <b>CAL 0%</b> " is flashing. To end " <b>CAL 0%</b> ", press <b>ENTER</b> to validate. You can press <b>SETUP</b> at any time to cancel the process.	
	Then the message " <b>CAL 100%</b> " flashing with " <b>CONNECT 100%</b> " asks the user to prepare the recorder for the 100% calibration.	
	Set input generator to deliver a signal corresponding to full scale (100%). Then press <b>ENTER</b> , the 100% calibration starts and " <b>CAL 100%</b> " is flashing. To end " <b>CAL 100%</b> ", press <b>ENTER</b> to validate. You can press <b>SETUP</b> at any time to cancel the process.	
	If you do not cancel the calibration (0% or 100%), " <b>END CAL</b> " is displayed for 3 seconds. Press <b>SETUP</b> to exit.	
	If you do not press <b>SETUP</b> , the message " <b>COPY ?</b> " is displayed after 3 seconds. Pressing <b>ENTER</b> will copy the calibration result on all similar connected ranges. Press <b>SETUP</b> if you do not want the result to be copied on the other similar connected ranges.	
<b>NOTE:</b>	Instrument should be allowed to warm up for a period of 30 minutes before calibration	



SUB-MATRIX	PARAMETER	CLASSIFICATION
<b>ANALOG INPUT</b>	<b>PV CALIB</b>	◆◆ □□

**NOTE:** Signal generators should have an accuracy of at least 0.05 %.  
 The type of wires depends on the sensor used.  
 Wait for 5 minutes after that particular sensor is connected (For compensation wires only).

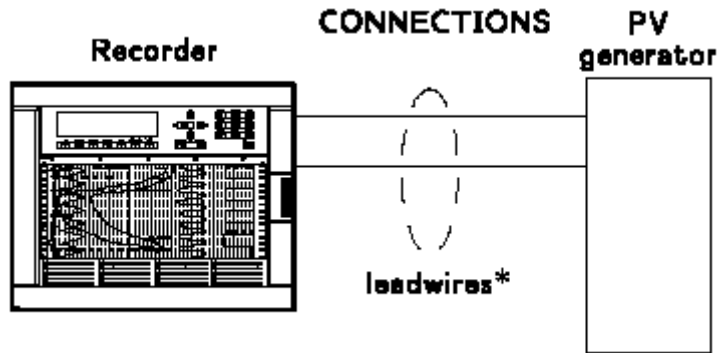

**! CAUTION**

**MAINTAIN CORRECT TEMPERATURE**

For T/C: Use compensation lead wires as the selected thermocouple. For RTD, mA: Use the copper lead wires. In thermocouple pay attention to the ambient temperature. If you are using a mV generator instead of direct thermocouple generator, the lead wires are in copper and you have to subtract from the mV value the mV corresponding to the ambient temperature of the rear terminals. (This eliminates the effect of the cold junction compensation)

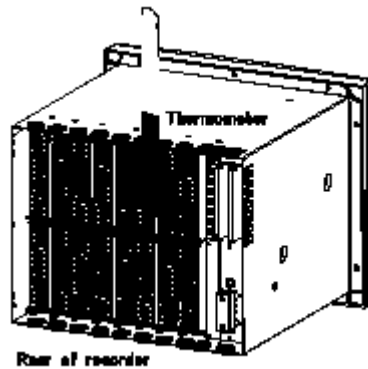

Failure to comply with these instructions may result in product damage

**NOTE:** Each time you change the sensor, the recorder is factory calibrated again.

## 8. SERVICE

SUB-MATRIX	PARAMETER	CLASSIFICATION
<b>ANALOG INPUT</b>	<b>CAL DATE</b>	◆ □
<b>DEFINITION:</b>	Shows you the date of the last PV calibration or junction calibration.	
<b>HOW TO USE/EXECUTE IT:</b>	You can only read the date. Press <b>SETUP</b> to escape.	

SUB-MATRIX	PARAMETER	CLASSIFICATION
<b>ANALOG INPUT</b>	<b>JUNCT °C</b>	◆ □
<b>DEFINITION:</b>	Shows value of the cold junction temperature compensation.	
<b>HOW TO USE/EXECUTE IT:</b>	You can only read the value. Press <b>SETUP</b> to escape.	
<b>NOTE:</b>	Value in °C.	

SUB-MATRIX	PARAMETER	CLASSIFICATION
<b>ANALOG INPUT</b>	<b>JUNCT T°</b>	◆ ◆ □ □
<b>DEFINITION:</b>	Allows the user to calibrate the cold junction temperature.	
<b>HOW TO USE/EXECUTE IT:</b>	When you enter in the sub-matrix, the message " <b>1T: 25.1 °C</b> " is displayed. Press ▼ or ▲, to modify the current value. Press <b>ENTER</b> to accept this value, or <b>SETUP</b> to cancel. If you accept, the calibration of the cold junction is executed. The message " <b>CAL JUNCT</b> " is flashing during few seconds. You can cancel the process by pressing <b>SETUP</b> If you do not cancel, the message " <b>END CAL.</b> " is displayed for three seconds.	
<b>NOTE:</b>	All units are delivered with the cold junction temperature already calibrated. The temperature must be gauged on the positive or negative terminals of the channel to calibrate.	

**SUB – MATRIX**

**PRINTER**

**PARAMETERS**

**CHART LG** page 8-11

**0% CHART** page 8-12

**100% CHART** page 8-13

**COLOR CALIB** page 8-14

**CHARACTERS** page 8-15

**PR ALL CONF** page 8-16

**PR HRD CONF** page 8-17

<i>SUB-MATRIX</i>	<i>PARAMETER</i>	<i>CLASSIFICATION</i>
<b>PRINTER</b>	<b>CHART LG</b>	◆□
<b>DEFINITION:</b>	Allows the user to know the length of remaining chart.	
<b>HOW TO USE/EXECUTE IT:</b>	You can only read the value. Press <b>SETUP</b> to escape.	

## 8. SERVICE

SUB-MATRIX

PARAMETER

CLASSIFICATION

PRINTER

0% CHART



**DEFINITION:**

Chart certification to show the current 0% chart position with 0% print carriage. This is a mechanical adjustment.

**HOW TO USE/EXECUTE IT:**

The message (channel nb) "**CAL 0%**" is displayed with a flashing number. This number corresponds to the present adjustment (= step motor).

To move to the right, increase this number or to the left, decrease the number. (You may use a negative number).

You can change the distance value by pressing the ▲ ▼ keys.

The recorder accepts the value by pressing **ENTER**.

You can leave the 0% chart service by pressing **SETUP**.

**NOTE:**

When you press **ENTER**, the head moves and prints at the new 0% chart calibration.

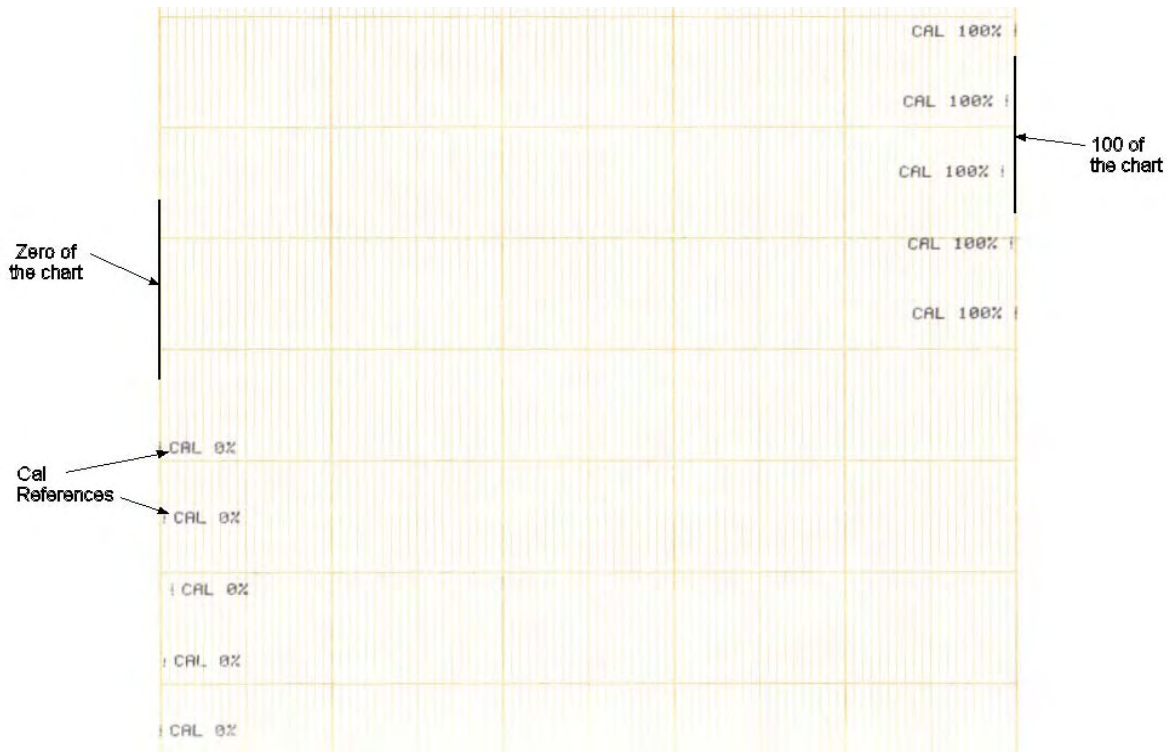

## 8. SERVICE

SUB-MATRIX	PARAMETER	CLASSIFICATION
<b>PRINTER</b>	<b>100% CHART</b>	◆◆□ □

**DEFINITION:** Chart certification to show the current 100% chart position with 100% print carriage. This is a mechanical adjustment.

**HOW TO USE/EXECUTE IT:** The message (channel nb) "**CAL 100%**" is displayed with a flashing number. This number corresponds to the present adjustment (= step motor).

To move to the right, increase this number or to the left, decrease the number. (You may use a negative number).

You can change the distance value by pressing the ▲ ▼ keys.

The recorder accepts the value by pressing **ENTER**.

You can leave the 100% chart service by pressing **SETUP**.

**NOTE:** When you press **ENTER**, the head moves and prints at the new 100% chart calibration.

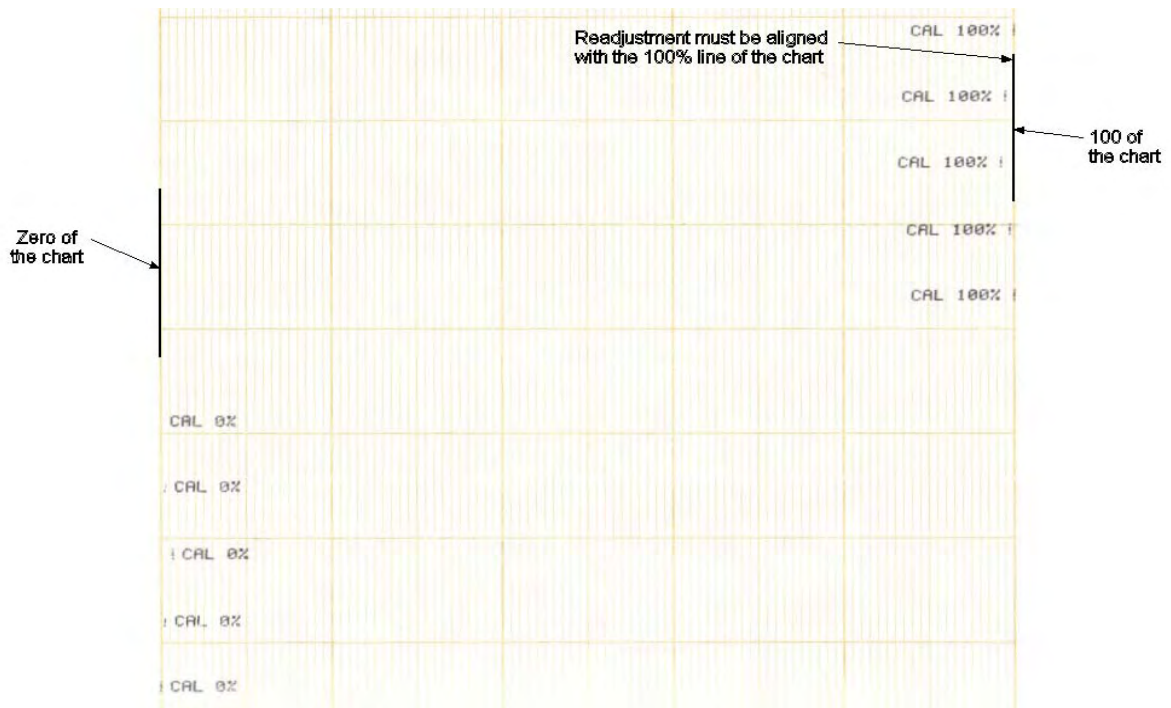

## 8. SERVICE

SUB-MATRIX

PARAMETER

CLASSIFICATION

**PRINTER**

**COLOR CALIB**



**DEFINITION:**

Test to show the current mechanical color adjustment.

**HOW TO USE/EXECUTE IT:**

Press **ENTER** to confirm or **SETUP** to leave.

Description:

- First step gives a rough idea of adjustment, 6 zones from left to right red, brown, green, purple, blue and black.
- Second step: String of blue characters
- Third step: String of purple characters
- Fourth step: String of green characters
- Fifth step: String of brown characters

Target is to get at least in the four strings: low dash from 0 to 4 in the good color and up dash from 4 to 0 in the good color.

To increase low dash number in the good color give a positive value by pressing the [key quantity proportional to graduations.

To increase up dash number in the good color give a negative value by pressing the ] key quantity proportional to graduations.

The recorder accepts value by pressing **ENTER** then the recorder prints the adjustment test with the new value.

You leave color calibration mode by pressing **SETUP**.

4 strings

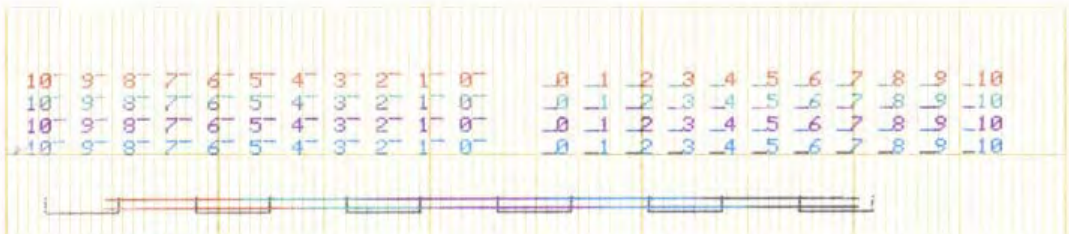

first step

SUB-MATRIX	PARAMETER	CLASSIFICATION
<b>PRINTER</b>	<b>CHARACTERS</b>	◆◆□ □

**DEFINITION:** Prints all the characters available with the printer.

**HOW TO USE/EXECUTE** The printer test begins when you enter in the function.

**IT:** You stop it by pressing **SETUP**.



SUB-MATRIX	PARAMETER	CLASSIFICATION
<b>PRINTER</b>	<b>PR ALL CONF</b>	◆◆□ □

**DEFINITION:** The recorder allows you to print its complete configuration data. Refer to section 4.5 "PRINT CONFIGURATION".

**NOTE:** **ADVICE:** We recommend you to execute a PRINT ALL CONF after having received your recorder.

During the printing, a message (IN PROGRESS) is shown on the lower display, indicating the current action.

You can stop the printing at any time by pressing the SETUP or DISPLAY keys. All other keys are deactivated.

The data is printed in reverse order so that you can read it in a logical order from top to bottom when completed.

PRINT ALL CONF does not print the MATH sub-matrix if your recorder does not have this option.

## 8. SERVICE

SUB-MATRIX

PARAMETER

CLASSIFICATION

**PRINTER**

**PR HRD CONF**



**DEFINITION:**

This function allows you to print the hardware configuration of your recorder and shows the type of current cards with their respective slots.

**NOTE:**

During the printing, the "IN PROGRESS" message is displayed. At the end of the printing, the initial message (PR01 PR HRD CONF) is displayed again.

**PRINTING FORMAT:**

\*\*\* HARDWARE CONFIG    18:25    15 SEP 97 \*\*\*

SLOT	J	K	L	M	N	P
CARD	D	D	D	R	R	.

COMM	.
------	---

SLOT	A	B	C	D	E	F
CARD	U	U	.	L	U	?

PCMCIA	.
--------	---

- D: 6 digital inputs
- R: 6 alarm relay outputs (digital outputs)
- L: 4 linear inputs (analog inputs)
- U: 4 universal inputs (analog inputs)
- C: 4 current outputs
- ?: incorrectly located card
- : no existing card

**NOTE:**

In this case, data is printed on BLANK paper. (Trace printing is momentarily stopped.)  
 The card abbreviations must be the same as those in the Model Selection Guide and in the "CARD USED" function ("MISCELLANEOUS" service).



SUB – MATRIX

# MMI

PARAMETER

## DISPL TEST

page 8-18

SUB-MATRIX	PARAMETER	CLASSIFICATION
PRINTER	DISPL TEST	◆ □

**DEFINITION:** Confirms that the display is operating correctly.

**HOW TO USE/  
EXECUTE IT:** When you enter in the function, every pixel flashes for 15 seconds.  
You can stop it by pressing **SETUP**.

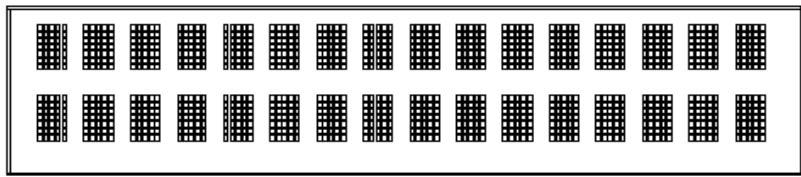

SUB – MATRIX

# EVENTS

PARAMETER

## EV STATE

page 8-19

SUB-MATRIX	PARAMETER	CLASSIFICATION
EVENTS	EV STATE	◆ □

**DEFINITION:** Shows the event status.

**HOW TO USE/  
EXECUTE IT:** You can only read the event status.  
Press **SETUP** to escape.

SUB – MATRIX

# MISCELLANEOUS

PARAMETERS

**RECORD TYPE** page 8-21

**SERIAL #** page 8-21

**FINAL TEST** page 8-21

**BACKUP** page 8-22

**RESTORE** page 8-22

**SOFTWARE** page 8-22

**HARDWARE** page 8-23

**CARD USED** page 8-23

*SUB-MATRIX*

*PARAMETER*

*CLASSIFICATION*

**MISCELLANEOUS**

**RECORD TYPE**



**DEFINITION:**

Shows the recorder type, 250 mmm (9.84 inch).

**HOW TO USE/EXECUTE IT:**

You can only read the value.

Press **SETUP** to escape

## 8. SERVICE

---

<i>SUB-MATRIX</i>	<i>PARAMETER</i>	<i>CLASSIFICATION</i>
<b>MISCELLANEOUS</b>	<b>SERIAL #</b>	◆□

---

**DEFINITION:** Shows the serial number of the product

**HOW TO USE/EXECUTE IT:** You can only read the value.  
Press **SETUP** to escape.

---

---

<i>SUB-MATRIX</i>	<i>PARAMETER</i>	<i>CLASSIFICATION</i>
<b>MISCELLANEOUS</b>	<b>FINAL TEST</b>	◆□

---

**DEFINITION:** Shows the date of final factory test.

**HOW TO USE/EXECUTE IT:** You can only read the value.  
Press **SETUP** to escape.

---

---

<i>SUB-MATRIX</i>	<i>PARAMETER</i>	<i>CLASSIFICATION</i>
<b>MISCELLANEOUS</b>	<b>BACKUP</b>	◆◆□□

---

**DEFINITION:** Saves time, date, remaining paper length and maths results before changing the battery.

**HOW TO USE/EXECUTE IT:** When you press **ENTER** in the function, the copy is executed.  
You can execute several backups before restoring the values. But you cannot execute many restores without any backup.

---

## 8. SERVICE

---

<i>SUB-MATRIX</i>	<i>PARAMETER</i>	<i>CLASSIFICATION</i>
<b>MISCELLANEOUS</b>	<b>RESTORE</b>	◆◆□□

---

**DEFINITION:** Restores the previous backup values after having changed the battery.

**HOW TO USE/EXECUTE IT:** When you press **ENTER** in the function, the restoration is executed.

---

<i>SUB-MATRIX</i>	<i>PARAMETER</i>	<i>CLASSIFICATION</i>
<b>MISCELLANEOUS</b>	<b>SOFTWARE</b>	◆□

---

**DEFINITION:** Shows the recorder software version.

**HOW TO USE/EXECUTE IT:** You can only read the value.

Press **SETUP** to escape.

---

<i>SUB-MATRIX</i>	<i>PARAMETER</i>	<i>CLASSIFICATION</i>
<b>MISCELLANEOUS</b>	<b>HARDWARE</b>	◆□

---

**DEFINITION:** Shows the recorder hardware version of the product.

**HOW TO USE/EXECUTE IT:** You can only read the value.

Press **SETUP** to escape.

---

<i>SUB-MATRIX</i>	<i>PARAMETER</i>	<i>CLASSIFICATION</i>
<b>MISCELLANEOUS</b>	<b>CARD USED</b>	◆□

---

**DEFINITION:**

Shows the type of cards connected to the recorder.

Possible choices are:

- **D**: 6 digital inputs
- **R**: 6 alarm relay outputs (digital outputs)
- **L**: 4 linear inputs (analog inputs)
- **U**: 4 universal inputs (analog inputs)
- **C**: 4 current outputs
- **?**: incorrectly located card
- **•**: no existing card

**HOW TO USE/EXECUTE IT:**

You can only read the value.

Press **SETUP** to escape.

---

**SUB – MATRIX**

**CURRENT 4/20 mA**

**PARAMETERS**

**CURR CALIB** page 8-25

**VIEW CURR** page 8-25

**FORCE CURR** page 8-26

## 8. SERVICE

---

<i>SUB-MATRIX</i>	<i>PARAMETER</i>	<i>CLASSIFICATION</i>
-------------------	------------------	-----------------------

---

**CURRENT 4/20 mA**

**CURR CALIB**



**DEFINITION:**

Calibrates the 4 mA and 20 mA references for the selected output.

**HOW TO USE/EXECUTE IT:**

The "**CALIB 4mA**" message flashes and the output is supposed to produce 4 mA. Press the ▲ and ▼ keys to start calibration until reaching the 4 mA output.  
In the case where you validated via the **ENTER** key, the "**CALIB 20mA**" message flashes and the output is supposed to produce 20 mA.  
Calibration starts when pressing the ▲ and ▼ keys until reaching the 20 mA output.  
Pressing **ENTER** makes the calibration stop (the "**END CAL**" message is displayed during 3s.)  
At any time, **SETUP** disables the 2 references calibration.

---

<i>SUB-MATRIX</i>	<i>PARAMETER</i>	<i>CLASSIFICATION</i>
-------------------	------------------	-----------------------

---

**CURRENT 4/20 mA**

**VIEW CURR**



**DEFINITION:**

Allows the output current to be displayed under the automatic format. (from 0 to 24 mA)

**HOW TO USE/EXECUTE IT:**

Cannot be modified. Press **SETUP** to escape.

---

<i>SUB-MATRIX</i>	<i>PARAMETER</i>	<i>CLASSIFICATION</i>
-------------------	------------------	-----------------------

---

**CURRENT 4/20 mA**

**FORCE CURR**



**DEFINITION:**

Allows forcing a current output manually on the 0-24 mA range.

**HOW TO USE/EXECUTE IT:**

Press the ▲ and ▼ keys to modify the output current.  
Press **SETUP** to escape.

**DEFINITION:**

[0 ... 24] mA  
3 digits after the decimal point

**DEFINITION:**

0.000





## 9. PRODUCT SPECIFICATION SHEET

<b>Technical data</b>	
<b>Technology</b>	Microprocessor-based (32 bits), with non-volatile memory. Flash memory for product software upgrade or specials, via the front jack.
<b>Analog inputs</b> Number of inputs  Input boards  Signal source    Basic mathematical Functions  Filter  Field calibration  Burnout    Scanning time   Input impedance  Stray rejection	<p>From 4 up to 64 in group of 4. Above 32 inputs, it could limit the total number of alarm outputs or digital inputs.</p> <p>2 types: 4 linear inputs per board: mV, V, mA 4 Universal inputs per board: mV, V, mA, T/C, RTD, Ohms</p> <p>Thermocouple with cold junction compensation, or with remote compensation temperature configurable between 0 to 80°C (32 to 176°F) Line resistance up to 1000 ohms for T/C, mV, mA, V RTD Pt 100 Ohms, 3-wire connections, 40 <math>\Omega</math> balanced max.</p> <p>Square Root extraction or channel differential are standard.</p> <p>Digital filter configurable per input from 0 to 99 seconds.</p> <p>Channel field calibration 0 to 100% span (or calibration of a group of identical channels) can be made to certify input sensor loop.</p> <p>T/C, mV, V (except following ranges) configurable to upscale, to downscale or none. Volt: -500, 0, 500 mV; -1, 0, 1 V; -2, 0, 2 V; -5, 0, 5 V; 0, 10 V; -10, 0, 10 V : Inherent to zero RTD: Inherent upscale. mA: Inherent downscale</p> <p>2 channels = 105 ms, 4 channels = 210 ms, 8 channels = 420 ms, 12 channels = 630 ms, 16 channels = 840 ms, 20 channels = 1 sec, 24 channels = 1.2 secs, ..., 64 channels = 3.3 secs (see section 1 for more details)</p> <p>10 Mohm for T/C, mV inputs, &gt;1 Mohm for volt inputs.</p> <p>Series mode &gt; 60 dB. Common mode at 120 V AC &gt; 130 dB.</p>
<b>Display</b> Fluorescent display   Brightness	<p>2 rows of 16 digits, 8.5 mm (.33 inch) high, matrix display. Can display 1 or 2 PV values (5 digits) per line, engineering units (5 digits), alarm status, tag name, maths, speed, event messages etc.</p> <p>The display brightness is configurable.</p>
<b>Record</b> Chart  Traces  Trace assignment  Scaling	<p>250 mm (9.84 inch) width</p> <p>Up to 32 traces, configurable in 6 colors, thin or thick traces, plus digital traces</p> <p>Traces are configurable on analog inputs, maths, comm. or digital inputs</p> <p>Per input, up to 2 analog scales can be configured to be printed on the chart with the engineering unit, channel reference and tag name. Each input can be configured independently. The scale can be linear, with up to 10 sub-divisions</p>

## 9. PRODUCT SPECIFICATION SHEET

<b>Technical data</b>	
Print mode	<p><b>Trend:</b> Up to 32 traces, with periodic chart documentation configurable in time, from 1 minute to 24 hours with date, time, scales, digital PV print-out over traces or on blank paper, with channel reference, digital traces, alarm messages and customer message</p> <p><b>Tabular:</b> Tabular print-out configurable in time from 1 to 1440 minutes with channel number, tag name, digital PV value, engineering unit, alarm status</p>
Zoning	Each input can be scaled between 0 to 100 % of the chart. (min. zone = 20%)
Printing group	Up to 2 groups of channels can be defined, with printing selection by: Alarm, logic inputs or triggers.
Pen carriage speed	1.4 seconds full scale
<b>Chart length</b>	Roll and Fanfold chart 35 m (115 ft.)
<b>Chart speed</b>	1 or 2 chart speeds, fully configurable, selected by: Logic input, alarm, communication, front key
Speed setting	Speeds 1 and 2 are configurable from 1 (0.04) up to 5000 mm/h (200 inch/h)
Resolution	Chart resolution is 0.19 mm (0.0075 inch)
<b>Product configuration</b>	
Access	The configuration can be accessed using front keys, PC Configurator or Communication.
Protection	2 password levels protect the unit configuration from unauthorized access. Level 1 = limited access, Level 2 = full protection
Front keys	Configurable and alphanumeric keys allow the operator to change the recorder operation.
PC configuration	Through the front jack the unit can be configured from a PC through a PC interface. This provides the facility to copy the configuration, modify, store, download or upload the configuration, access service diagnostics, and also to upgrade the recorder firmware.
<b>Logic inputs</b> (optional)	Up to 48 input contacts, organized in groups of 6 contacts per card
Number of inputs	Dry contacts (5 mA - 5 V dc)
Actions	<p>Change chart speed 1 to speed 2, tab interval 1 to tab interval 2, digital print-out, print message, print inhibit, event traces, print math calculations.</p> <p>Change range, start/stop math operations.</p> <p>Change print group, actuate a relay output.</p> <p>Up to 48 event traces are configurable in color and position from 0 to 100% of the chart.</p>
<b>Alarms</b>	
Setpoints	Up to 64 alarm setpoints, freely assignable to analog inputs, maths or comm.
Alarm type	High, low, change rate high, change rate low, change rate high-low or deviation with configurable alarm occurrence

## 9. PRODUCT SPECIFICATION SHEET

<b>Technical data</b>	
<p><b>Alarms</b> (continued) Actions</p> <p>Relay output (optional)</p> <p>Alarm event</p>	<p>Can trigger a message, print channel in red in alarm, print in alarm, change the range, change the speed/tabular, print digital PV's, start/stop the maths, select the print group, actuate a relay output.</p> <p>Up to 48 internal relays: 2 A, 250 V ac on resistive load. 1 SPST contact output, normally closed contact (NC), configurable to normally open (NO), configurable alarm relay acknowledgment.</p> <p>The recorder can be configured to display events such as: 1 alarm, 1 channel in burnout, paper out, battery failed, communication interrupted.</p>
<p><b>Alphanumeric documentation</b> Messages</p> <p>Process values</p> <p>Tag name</p> <p>Chart scales</p> <p>Periodic Report</p>	<p>Up to 48 freely assignable messages of 50 characters each. Can be printed with or without date/time over the traces by alarms, logic inputs, communication, when alarm is ON, OFF or ON/OFF. Message 1 can be configured to print a header message in Tabular mode.</p> <p>Periodic digital print-out at time intervals configurable from 1 minute to 24 hours or through alarms, digital inputs, communication</p> <p>Each channel can have up to an 8 character name.</p> <p>Each can be configured from 0 to 9 subdivisions</p> <p>Startup time and period are configurable. Min., max., average of selected channels (or math computation) are printed in alphanumeric. Report size max. = 20 lines.</p>
<p><b>User-Defined Actuation</b></p>	<p>Up to 50 breakpoints can be used to define a custom range/actuation. Up to 2 ranges can be defined using the PC Configurator.</p>
<p><b>Mathematical package</b> (optional)</p> <p>Actions</p>	<p>Many functions are available such as: basic maths functions (+, -, x), square root, Fo, totalization mass flows, energy consumption, averages, min., max., timers, carbon potential, alarm logic pulses totalization, RH, .. The calculations are stored during power interruption.</p> <p>The results can be recorded as a trace, a tabular print-out, or in a periodic report, or sent to the communication link, or used to generate a current output signal.</p>
<p><b>Communication</b> (optional) Protocols</p>	<p>ASCII in RS 232, RS 422, RS 485 MODBUS RTU in RS 422, RS 485 Ethernet/Modbus RTU Bridge Interface Interface configured with standard IP address and is utilized with 3<sup>rd</sup> party software that provides TCP/IP modbus driver and OPC capability</p>

## 9. PRODUCT SPECIFICATION SHEET

<b>Technical data</b>	
<b>PCMCIA (optional)</b> PCMCIA cards  Actions  PC analysis	PCMCIA memory cards are ATA type II compatible and use flash technology for a longer data retention. Memory size starts from 2 Mb up to 75 Mb  Archiving of PV traces, alarms and events with file names. Logging time selectable from 1 second up to 30 minutes.  TrendManager Pro software provides an easy and powerful way to analyze trend, alarm and event files as well as to export them in spreadsheet format. (CSV)
<b>Retransmitting signals (optional)</b>  Current output	Up to 8 signals, 4 to 20 mA dc, can be generated by the recorder (organized in blocks of 4 output signals). Max. Line impedance = 400 Ohms These can be configured for: analog traces, math calculations, PV's from the communication link. The zero and span are configurable. Factory accuracy: 0.15% Field calibration accuracy: 0.05% Temperature drift: 75 ppm
<b>Clock timer</b>  Format Power interruption Accuracy	Year, month, hour, minute can be set Battery backed (10 years time, 3 years power off) 10 <sup>-5</sup> at reference conditions
<b>Power supply</b>	100 to 240 V ac/dc (24 V ac/dc on special request) Power consumption = 100 VA max.
<b>Packaging</b>  Weight Front bezel Panel cutout Depth Front protection Lock Door Mounting Wiring	22 kg max. (48 lbs) 310 x 387 mm (12.2 x 15.24 inches) 278 x 348 mm (10.9 x 13.7 inches) 320 mm (12.6 inches) including the rear cover IP 55 Latch, optional key (DIN 43832-N) Die cast aluminum: Dark gray or black (optional), door opens to 180° Panel mounting ±30° from the horizontal Screw terminals: Terminal blocks plug on to the boards at the back of the recorder
<b>Noise immunity/Isolation</b>	This product is in conformity with the protection requirements of the following European Council Directives: <ul style="list-style-type: none"> <li>▪ 73/23/EEC, the Low Voltage Directive and 89/336/EEC, the EMC Directive. Conformity of this product with any other "CE Mark" Directive(s) shall not be assumed.</li> <li>▪ EMC Classification: EN61326-1 Electromagnetic Compatibility – General Emission Standard, Part 2: Industrial Environment.</li> <li>▪ EN61326-1 Electromagnetic Compatibility – General Immunity Standard, Part 2: Industrial Environment.</li> </ul>
<b>Safety protection</b>	Complies with EN61010-1 and UL 3121 for process control instrumentation. Pollution Degree 2. Installation Category II

## 9. PRODUCT SPECIFICATION SHEET

<b>Technical data</b>		
<b>Electrical insulation</b> - Input to input  - Input/ground - Alarm relay/ground - Input/line; Line/ground - Current output/ground - Logic/ground	- Functional isolation for continuous operation at 280 V ac or 400 V dc (except for RTD) - Test voltage 2.1 kV dc for 1 minute - Test voltage 3.25 kV dc for 1 minute - Test voltage 3.25 kV dc for 1 minute - Test voltage 3.25 kV dc for 1 minute - Test voltage 500 V dc for 1 minute	
<b>Temperature</b> Ambient Storage	0 to 50°C (32 to 122°F) for roll paper, 0 to 40°C (32 to 104°F) for fanfold paper -40 to 70°C (-40 to 160°F)	
<b>Humidity</b> Roll chart Fan fold	10 to 90% RH non-condensing 15 to 80% RH non-condensing	
<b>Vibrations</b>	Frequency: 10 to 60 Hz, amplitude 0.07 mm 60 to 150 Hz, acceleration 1 g	
<b>Accuracy</b> Reference conditions         Accuracy	Temperature = 23°C ±2°C (73°F ±3°F) Humidity = 65% RH ±5% Line voltage = Nominal ±1% Source resistance = 0 Ohm Series mode and common mode = 0 V Frequency = Nominal ±1%  <b>Field calibration accuracy 0.05% of the selected range (IEC 873)</b> Factory calibration = 0.1% of the selected range Chart resolution = 0.18 mm (0.007"). Cold junction accuracy = ±0.5°C (32.9°F)	
<b>Rated limits and associated drifts</b> <b>Parameter</b> Temperature   Supply voltage  Source resistance    Humidity Long-term stability Vibrations	<b>Rated limits</b> 0 to 50°C (32 to 120°F)  85 to 250 V  T/C, mV  RTD  * On PT100°C ≥400°C and JIS ≥400°C and other ranges	<b>influence on accuracy</b> 0.15% per 10°C of change (See note below) Cold junction 0.3°C/10°C  No influence  6 μV per 100 Ohms of line Resistance max. = 1000 Ohms  0.1°C per Ohm in each wire. Balanced leads: 40 Ohms max. in each wire *  0.1% max. 0.1% per year

NOTE: 0.5% per 10°C on Cu 10 ohms  
 0.3% per 10°C on Pt 100°C ≤200°C

## 9. PRODUCT SPECIFICATION SHEET

---

### AVAILABLE RANGES

LINEAR			
DISPLAY	RANGE	DISPLAY	RANGE
<b>mV:</b> 0/10 mV -10/10 mV 0/20 mV -20/20 mV 0/50 mV -50/50 mV 10/50 mV 0/100 mV -100, 0, 100 mV 0/500 mV -500/500 mV	<b>mV:</b> 0/10 mV -10, 0, 10 mV 0, 20 mV -20, 0, 20 mV 0, 50 mV -50, 0, 50 mV 10, 50 mV 0, 100 mV -100, 0, 100 mV 0, 500 mV -500, 0, 500 mV	<b>Volt:</b> 0/1 V -1/1 V 0/2 V -2/2 V 0/5 V -5/5 V 1/5 V 0/10 V -10/10 V	<b>Volt:</b> 0, 1 V -1, 0, 1 V 0, 2 V -2, 0, 2 V 0, 5 V -5, 0, 5 V 1, 5 V 0, 10 V -10, 0, 10 V
<b>mA:</b> 0/20 mA 4/20 mA	<b>mA:</b> 0/20 mA* 4, 20 mA*		

\* The mA inputs have to be connected on a 250  $\Omega$  input resistor across the input terminals.

## 9. PRODUCT SPECIFICATION SHEET

### AVAILABLE RANGES *(continued)*

RTD / OHMS			
DISPLAY	RANGE	REFERENCE ACCURACY RANGE	STANDARD
Pt 100 Ω et 0 °C: -50/150 C -58/302 F 0/100 C 32/212 F 0/200 C 32/392 F 0/400 C 32/752 F -200/800 C -328/1472 F	Pt 100 Ω et 0 °C: -50, 0, 150 °C -58, 0, 302 °F 0, 100 °C** 32, 212 F** 0, 200 C 32, 392 °F 0, 400 °C 32, 752 °F -200, 0, 800 °C -328, 0, 1472 °F	Pt 100 Ω et 0 °C:- 50, 0, 150 °C -58, 0, 302 °F 0, 100 °C** 32, 212 °F** 0, 200 °C 32, 392 °F 0, 400 °C 32, 752 °F -200, 0, 800 °C -328, 0, 1472 °F	IEC 751 – 1986 IEC 751 – 1986 IEC 751 – 1986 IEC 751 – 1986 IEC 751 – 1986 IEC 751 – 1986 IEC 751 – 1986 IEC 751 – 1986 IEC 751 – 1986 IEC 751 – 1986
Ni 50 ohms: -80/320 C -112/608 F	Ni 50 ohms: -80, 0, 320 °C -112, 0, 608 °F	Ni 50 ohms: 0, 320 °C 32, 608 °F	Edison #2045A – 1962 Edison #2045A – 1962
Ni 508 ohms: -80/150 C -112/302 F	Ni 508 ohms: -80, 0, 150 °C -112, 0, 302 °F	Ni 508 ohms: 0, 150 °C 32, 302 °F	
Cu 10 ohms: -20/250 C -4/482 F	Cu 10 ohms: -20, 0, 250 °C*** -4, 0, 482 °F***	Cu 10 ohms: -20, 0, 250 °C*** -4, 0, 482 °F***	General Electric General Electric
Ohms: 0/200Ω 0/2000 Ω	Ohms: 0, 200Ω 0, 2000 Ω	Ohms: 0, 200Ω 0, 2000 Ω	
JIS: -50/150 C -58/302 F 0/100 C 32/212 F 0/200 C 32/392 F 0/400 C 32/752 F -200/500 C -328/932 F	JIS: -50, 0, 150 °C -58, 0, 302 °F 0, 100 °C** 32, 212 °F** 0, 200 °C 32, 392 °F 0, 400 °C 32, 752 °F -200, 0, 500 °C -328, 0, 932 °F	JIS: -50, 0, 150 °C -58, 0, 302 °F 0, 100 °C** 32, 212 °F** 0, 200 °C 32, 392 °F 0, 400 °C 32, 752 °F -200, 0, 500 °C -328, 0, 932 °F	JIS C 1604 – 1981 JIS C 1604 – 1981 JIS C 1604 – 1981 JIS C 1604 – 1981 JIS C 1604 – 1981 JIS C 1604 – 1981 JIS C 1604 – 1981 JIS C 1604 – 1981 JIS C 1604 – 1981 JIS C 1604 – 1981

\*\* Accuracy: 0.25 % \*\*\* Accuracy: 0.5 %

## 9. PRODUCT SPECIFICATION SHEET

### AVAILABLE RANGES *(continued)*

THERMOCOUPLES			
DISPLAY	RANGE	REFERENCE ACCURACY RANGE	STANDARD
<b>J:</b> -50/150 C -58/302 F 0/400 C 32/752 F -200/870 C -328/1598 F	<b>J:</b> -50, 0, 150 °C -58, 0, 302 °F 0, 400 °C 32, 752 °F -200, 0, 870 °C -328, 0, 1598 °F	<b>J:</b> -50, 0, 150 °C -58, 0, 302 °F 0, 400 °C 32, 752 °F -170, 0, 870 °C -274, 0, 1598 °F	IEC 584-1 (ITS90) IEC 584-1 (ITS90) IEC 584-1 (ITS90) IEC 584-1 (ITS90) IEC 584-1 (ITS90) IEC 584-1 (ITS90)
<b>L:</b> -50/150 C -58/302 F 0/400 C 32/752 F -200/870 C -328/1598 F	<b>L:</b> -50, 0, 150 °C -58, 0, 302 °F 0, 400 °C 32, 752 °F -200, 0, 870 °C -328, 0, 1598 °F	<b>L:</b> -50, 0, 150 °C -58, 0, 302 °F 0, 400 °C 32, 752 °F -170, 0, 870 °C -274, 0, 1598 °F	DIN43710 (IPTS68) DIN43710 (IPTS68) DIN43710 (IPTS68) DIN43710 (IPTS68) DIN43710 (IPTS68) DIN43710 (IPTS68)
<b>K:</b> 0/400 C 32/752 F 0/800 C 32/1472 F 0/1200 C 32/2192 F -200/1370 C -328/2498 F	<b>K:</b> 0, 400 °C 32, 752 °F 0, 800 °C 32, 1472 °F 0, 1200 °C 32, 2192 °F -200, 0, 1370 °C -328, 0, 2498 °F	<b>K:</b> 0, 400 °C 32, 752 °F 0, 800 °C 32, 1472 °F 0, 1200 °C 32, 2192 °F -170, 0, 1370 °C -274, 0, 2498 °F	IEC 584-1 (ITS90) IEC 584-1 (ITS90) IEC 584-1 (ITS90) IEC 584-1 (ITS90) IEC 584-1 (ITS90) IEC 584-1 (ITS90) IEC 584-1 (ITS90)
<b>R:</b> -20/1760 C -4/3200 F	<b>R:</b> -20, 0, 1760 °C -4, 0, 3200 °F	<b>R:</b> 100, 1760 °C 212, 3200 °F	IEC 584-1 (ITS90) IEC 584-1 (ITS90)
<b>S:</b> 0/1600 C 32/2912 F -20/1760 C -4/3200 F	<b>S:</b> 0, 1600 °C 32, 2912 °F -20, 0, 1760 °C -4, 0, 3200 °F	<b>S:</b> 100, 1600 °C 212, 2912 °F 100, 1760 °C 212, 3200 °F	IEC 584-1 (ITS90) IEC 584-1 (ITS90) IEC 584-1 (ITS90) IEC 584-1 (ITS90)
<b>N:</b> 0/400 C 32/752 F 0/800 C 32/1472 F 0/1200 C 32/2192 F -200/1300 C -328/2372 F	<b>N:</b> 0, 400 °C 32, 752 °F 0, 800 °C 32, 1472 °F 0, 1200 °C 32, 2192 °F -200, 0, 1300 °C -328, 0, 2372 °F	<b>N:</b> 0, 400 °C 32, 752 °F 0, 800 °C 32, 1472 °F 0, 1200 °C 32, 2192 °F -170, 1300 °C -274, 2372 °F	IEC 584-1 (ITS90) IEC 584-1 (ITS90) IEC 584-1 (ITS90) IEC 584-1 (ITS90) IEC 584-1 (ITS90) IEC 584-1 (ITS90) IEC 584-1 (ITS90) IEC 584-1 (ITS90)



## 9. PRODUCT SPECIFICATION SHEET

### AVAILABLE RANGES *(continued)*

THERMOCOUPLES			
DISPLAY	RANGE	REFERENCE ACCURACY RANGE	STANDARD
T: -50/150 C -58/302 F 0/150 C 32/302 F 50/150 C 122/302 F -200/400 C -328/752 F	T: -50, 0, 150 °C -58, 0, 302 °F 0, 150 °C 32, 302 °F 50, 150 °C 122, 302 °F -200, 0, 400 °C -328, 0, 752 °F	T: -50, 0, 150 °C -58, 0, 302 °F 0, 150 °C 32, 302 °F 50, 150 °C 122, 302 °F -150, 0, 400 °C -238, 0, 752 °F	IEC 584-1 (ITS90) IEC 584-1 (ITS90) IEC 584-1 (ITS90) IEC 584-1 (ITS90) IEC 584-1 (ITS90) IEC 584-1 (ITS90) IEC 584-1 (ITS90) IEC 584-1 (ITS90)
U: -50/150 C -58/302 F 0/150 C 32/302 F 50/150 C 122/302 F -200/400 C -328/752 F	U: -50, 0, 150 °C -58, 0, 302 °F 0, 150 °C 32, 302 °F 50, 150 °C 122, 302 °F -200, 0, 400 °C -328, 0, 752 °F	U: -50, 0, 150 °C -58, 0, 302 °F 0, 150 °C 32, 302 °F 50, 150 °C 122, 302 °F -150, 0, 400 °C -238, 0, 752 °F	DIN43710 (IPTS68) DIN43710 (IPTS68) DIN43710 (IPTS68) DIN43710 (IPTS68) DIN43710 (IPTS68) DIN43710 (IPTS68) DIN43710 (IPTS68) DIN43710 (IPTS68)
NiMo: 0/1400 C 32/2552 F	NiMo: 0, 1400 °C 32, 2552 °F	NiMo: 0, 1400 °C 32, 2552 °F	General Electric (IPTS68) General Electric (IPTS68)
Moco: 0, 1400 C 32/2552 F	Moco: 0, 1400 °C 32, 2552 °F	Moco: 0, 1400 °C 32, 2552 °F	
W-W26: -20/2320 C -4/4208 F	W-W26: -20, 0, 2320 °C -4, 0, 4208 °F	W-W26: 500, 2100 °C 932, 3812 °F	IPTS68 IPTS68
W5-W26: -20/2320 C -4/4208 F	W5-W26: -20, 0, 2320 °C -4, 0, 4208 °F	W5-W26: 0, 1800 °C 32, 3272 °F	IPTS68 IPTS68
PR20-40: PR20 1800 C PR20 3272 F	PR20-40: 0, 1800 °C 32, 3272 °F	PR20-40: 600, 1800 °C 1110, 3300 °F	IPTS68 IPTS68
B: 40/1820 C 104/3308 F	B: 400, 1820 °C 752, 3308 °F	B: 400, 1820 °C 752, 3308 °F	IEC 584-1 (ITS90) IEC 584-1 (ITS90)

**Note:** For non-linear temperature transmitter, the transmitter range MUST be identical to the input range of the recorder.

## ***9. PRODUCT SPECIFICATION SHEET***

---

## 10. PROMPTS TRANSLATIONS

---

### TABLE OF CONTENTS

**Section Page**

10.1	MATRICES .....	10-2
------	----------------	------

## 10. PROMPTS TRANSLATIONS

---

### 10.1 MATRICES

EN	FR	GE	IT	SP
ANALOG INPUT	ENTREE ANALOG	ANALOGUEINGANG	INGR ANALOGICO	ENTRADAS ANALOG
CHART	DIAGRAMME	DIAGRAMM	CARTA	GRAFICO
ALARM	ALARME	ALARM	ALLARME	ALARMA
DIGITAL	LOGIQUE	BINÄREINGANG	DIGITALE	DIGITAL
MESSAGES	MESSAGES	TEXTMELDUNGEN	MESSAGGI	MENSAJES
PRINTER	IMPRIMANTE	DRUCKER	STAMPANT	IMPRESORA
CHART DOC	DOC DIAGRAMME	DIAGRAMMFORMAT	DOC CARTA	DOC GRAFICO
MMI	AFFICH/ CLAVIER	MMI	TASTIERA	MMI
EVENTS	EVENEMENTS	MELDUNGEN	EVENTI	SUCESO
MISCELLANEOUS	DIVERS	ANDERE PARAMETER	MISTO	VARIOS
PERIODIC REPORT	RAP PERIODIQUE	PERIOD PROTOKOLL	RAPPORTO PERIOD	INFORME PERIODIC
CURRENT 4/20 mA	COURANT 4/20 mA	STROM 4/20 mA	CORRENTE 4/20 mA	CORRIENT 4/20 mA

**ANALOG INPUT**

<b>EN</b>	<b>FR</b>	<b>GE</b>	<b>IT</b>	<b>SP</b>
SENSOR	CAPTEUR	GEBERART	SENSORE	SENSOR
RANGE	GAMME	BEREICH	CAMPO	RANGO
EXT COMP	T/C COMP	EXT KOMPENS	COMP EST	COMP EXT
FILTER	FILTRE	FILTER	FILTRO	FILTRO
LOW VALUE	VAL. BASSE	UNTER WERT	VALORE BASS	VALOR INFR
HIGH VALUE	VAL. HAUTE	OBERER WERT	VALORE ALTO	VALOR SUPR
STD MATH	OPTION MATH	STD MATH	OPZIONE MAT	OPC MATM
DIFF WITH	-VOIE n°	KANAL DIFF	CANALE DIF	CA # DIF
BURNOUT	RUPTURE CAP	BRUCHSICHER	SICUREZ	ROTURA
LOW ADJUST	AJUST BAS	UNTERE JUST	REG BASSO	AJUST BAJO
HIGH ADJUST	AJUST HAUT	OBERE JUST	REG ALTO	AJUST ALTO

---

## 10. PROMPTS TRANSLATIONS

---

### CHART

EN	FR	GE	IT	SP
TRACE	TRACE	SPUR	TRACCIA	TRAZO
DESTINATION	DESTINATION	ZIEL	DESTINAZIONE	DESTINO
FORMAT	DECIMAL	DRUCKFORMAT	FORMATO	FORMATO
MIN RANGE 1	GAMME 1 MIN	MIN BER 1	CAMPO MIN 1	MIN RANGO 1
MAX RANGE 1	GAMME 1 MAX	MAX BER 1	CAMPO MAX 1	MAX RANGO 1
RG 1 COLOR	COULEUR G1	FARBE BER 1	COLOR CAMP1	COL RANGO 1
MIN RANGE 2	GAMME 2 MIN	MIN BER 2	CAMPO MIN 2	MIN RANGO 2
MAX RANGE 2	GAMME 2 MAX	MAX BER 2	CAMPO MAX 2	MAX RANGO 2
RG 2 COLOR	COULEUR G2	FARBE BER 2	COLOR CAMP2	COL RANGO 2
ENG UNIT	UNITE VOIE	TECHN EINH	UNITA ING	UNID ING
TAG NAME	NOM VOIE	KA BEZEICHN	TARGHETTA	NOMBRE IDNT
RANGE USED	GAMME UTILE	VERW BEREICH	CAMPO USATO	RANGO USADO
0% ZONE	0% ZONE	0% ZONE	0% ZONA	0% ZONA
100% ZONE	100% ZONE	100% ZONE	100% ZONA	100% ZONA
SUB DIV	SOUS-DIV	SKALENTEILG	N DIVISIONE	BAJA DIVIS
GROUP DEF	DEF GROUP	DEF GRUPPE	DEF GRUPPO	DEF GRUPO

## 10. PROMPTS TRANSLATIONS

---

### ALARM

EN	FR	GE	IT	SP
SP VALUE	CONSIGNE	GRENZWERT	VALORE SP	VALOR PC
APPLY ON	OPERE SUR	KANAL-NR	CANALE	CANAL
ALARM TYPE	TYPE ALARME	ALARMTYP	TIPO ALLARM	TIPO ALARMA
HYSTERESIS	HYSTERESIS	HYSTERESE	ISTERESIS	HISTERESIS
OCCURRENCE	OCCURRENCE	AUFTRITT	STATO	OCURRCIA
DIFF WITH	-VOIE n °	KANAL DIFF	CANALE DIF	CA # DIF
ACTION	ACTION	FUNKTION	AZIONE	ACCION
RELAY NUM	RELAIS N °	RELAIS-NR	NUMERO RELE	RELE #
ACKNOWLEDGE	ACQUITTER	QUITTIERUNG	PAGARE	RECONOCIDO
MSG NUMBER	MESSAGE N °	TEXT NUMMER	NUMERO MSG	MENSAJE #
MSG COLOR	COULEUR MSG	FARBE TEXT	COLORE MSG	COLOR MSJE
MSG	TYPE MSG	TEXT AUSDR	TIPO MESSAG	TIPO MSJE
RED IN AL	ROUGE EN AL	ROTDRUCK	ROSSO IN AL	ROJO EN AL

## 10. PROMPTS TRANSLATIONS

---

### DIGITAL

EN	FR	GE	IT	SP
TYPE	TYPE	TYP	TIPO	TIPO
DIFF WITH	-VOIE N °	KANAL DIFF	CANALE DIFF	CA # DIF
ACTION	ACTION	FUNKTION	AZIONE	ACCION
RELAY NUM	RELAIS N °	RELAIS-NR	NUMERO RELE	RELE #
ACKNOWLEDGE	ACQUITTER	QUITTIERUNG	PAGARE	RECONOCIDO
MSG NUM	MESSAGE N °	TEXTNUMMER	NUMERO MSG	MENSAJE
MSG COLOR	COULEUR MSG	FARBE TEXT	COLORE MSG	COLOR MSJE
MSG TYPE TYPE	MSG TEXT	TEXT AUSDR	TIPO MESSAG	TIPO MSJE
TRACE	TRACE	SPUR	TRACCIA	TRAZO
OFF POSITN	POSITN OFF	AUFZ AUS %	POSIZIO OFF	POSICION OF
ON POSITN	POSITN ON	AUFZ EIN %	POSIZION ON	POSICION ON
TRACE COLOR	COULEUR TRA	FARBESPUR	COLOR TRACC	COLOR TRAZO
RED IN AL	ROUGE EN AL	ROTDRUCK	ROSSO IN AL	ROJO EN AL

### MESSAGES

EN	FR	GE	IT	SP
MESSAGE	MESSAGE	TEXTMELDUNG	MESSAGIO	MENSAJE



## 10. PROMPTS TRANSLATIONS

---

### PRINTER

EN	FR	GE	IT	SP
SPEED UNIT	UNITE	GESCHW EINH	VELOC USATA	UNID VEL
SPEED 1	VITESSE 1	GESCHWIND 1	VELOCITA 1	VELOCD 1
SPEED 2	VITESSE 2	GESCHWIND 2	VELOCITA 2	VELOCD 2
INTERVAL 1	INTERVALL 1	INTERVALL 1	INTERVAL 1	INTERVAL 1
INTERVAL 2	INTERVALL 2	INTERVALL 2	INTERVAL 2	INTERVAL 2
SP/INT USED	VIT/INT UTL	GEWÄHLT	VEL/INT USI	VEL/INT USD
RECORD MODE	TYPE ENREGI	BETRIEBSART	TIPO REG	MODO REGST
PRINT MODE	TYPE IMPRES	AUSDRUCK	TIPO STAMPA	MODO IMPRS
CHART LG	LONG.PAPIER	PAPIERLÄNGE	CARTA	LGD GRAF

## 10. PROMPTS TRANSLATIONS

---

### CHART DOC

<b>EN</b>	<b>FR</b>	<b>GE</b>	<b>IT</b>	<b>SP</b>
<b>PRT INTRVAL</b>	<b>INTV IMPRES</b>	<b>DRU INTERVA</b>	<b>INTV STP</b>	<b>INTV IMP</b>
<b>INFORMATION 01</b>	<b>INFORMATION 01</b>	<b>INFORMATION 01</b>	<b>INFORMATION 01</b>	<b>INFORMATION 01</b>
<b>INFORMATION 02</b>	<b>INFORMATION 02</b>	<b>INFORMATION 02</b>	<b>INFORMATION 02</b>	<b>INFORMATION 02</b>
<b>INFORMATION 03</b>	<b>INFORMATION 03</b>	<b>INFORMATION 03</b>	<b>INFORMATION 03</b>	<b>INFORMATION 03</b>
<b>INFORMATION 04</b>	<b>INFORMATION 04</b>	<b>INFORMATION 04</b>	<b>INFORMATION 04</b>	<b>INFORMATION 04</b>
<b>INFORMATION 05</b>	<b>INFORMATION 05</b>	<b>INFORMATION 05</b>	<b>INFORMATION 05</b>	<b>INFORMATION 05</b>
<b>INFORMATION 06</b>	<b>INFORMATION 06</b>	<b>INFORMATION 06</b>	<b>INFORMATION 06</b>	<b>INFORMATION 06</b>
<b>INFORMATION 07</b>	<b>INFORMATION 07</b>	<b>INFORMATION 07</b>	<b>INFORMATION 07</b>	<b>INFORMATION 07</b>
<b>INFORMATION 08</b>	<b>INFORMATION 08</b>	<b>INFORMATION 08</b>	<b>INFORMATION 08</b>	<b>INFORMATION 08</b>
<b>INFORMATION 09</b>	<b>INFORMATION 09</b>	<b>INFORMATION 09</b>	<b>INFORMATION 09</b>	<b>INFORMATION 09</b>
<b>INFORMATION 10</b>	<b>INFORMATION 10</b>	<b>INFORMATION 10</b>	<b>INFORMATION 10</b>	<b>INFORMATION 10</b>
<b>TRACE REF</b>	<b>REF TRACE</b>	<b>SPURKENNZG</b>	<b>REF TRACCIA</b>	<b>REF TRAZO</b>
<b>FUNCT MSG</b>	<b>MSG FONCT</b>	<b>STAND TEXT</b>	<b>MSG FUNZ</b>	<b>FUNZ MSJE FUNC</b>

---

## 10. PROMPTS TRANSLATIONS

### MMI

EN	FR	GE	IT	SP
HOLD KEY	TOUCHE HOLD	HOLD TASTE	TAST HOLD	TECLA HOLD
DISPLAY KEY	TCH DISPLAY	DISPLAY TASTE	TAST DISPLA	TECLA DISPL
PRINT KEY	TOUCH PRINT	DRUCK TASTE	TAST PRINT	TECLA PRINT
RESET KEY	TOUCH RESET	RÜCKS TASTE	TAST RESET	TECLA RESET
ACK KEY	TOUCHE ACK	QUITTIER TA	TAST ACK	TECLA ACK
DISPLAY HI	AFFICH HAUT	OBE ANZEIGE	INDIC SUP	VISUALZ SUP
DISPLAY LO	AFFICH BAS	UNT ANZEIGE	INDIC INF	INF VISUALZ INF
BRIGHT	LUMIERE	HELLIGKEIT	LUMINOS	BRILLO
F1 KEY	TOUCHE F1	F1 TASTE	TAST F1	TECLA F1
F2 KEY	TOUCHE F2	F2 TASTE	TAST F2	TECLA F2

### EVENTS

EN	FR	GE	IT	SP
EVENT TYPE	TYPE EVENMT	MELDUNG TYP	TIPO EVENTO	TIPO SUC
RELAY NUM	RELAIS N°	RELAIS-NR	NUMERO RELE	RELE #
DISPLAY	AFFICHAGE	ANZEIGE	INDICATORE	VISUALZ

## 10. PROMPTS TRANSLATIONS

---

### MISCELLANEOUS

EN	FR	GE	IT	SP
TIME	HEURE	ZEIT	ORA	HORA
DATE	DATE	DATUM	DATA	FECHA
LANGUAGE	LANGUE	SPRACHE	LINGUA	IDIOMA
INTERFACE	INTERFACE	INTERFACE	INTERFACCIA	INTERFACE
IDENTIF #	No PAPIER	DIAGRAMM NR	N IDENT	IDENTIF #
FREQUENCY	FREQUENCE	FREQUENZ	FREQUENZA	FRECUENCIA
PASSWORD 1	CODE No 1	PASSWORT 1	CODICE 1	CLAVE 1
PASSWORD 2	CODE No 2	PASSWORT 2	CODICE 2	CLAVE 2
OPTIONS	OPTIONS	OPTIONEN	OPZIONI	OPCIONES

### PERIODIC REPORT

EN	FR	GE	IT	SP
SYNCHRO AT	SYNCHRO A	SYNCHRO BEI	SINCRONISMO	SINCRO A
PERIOD	PERIODE	PERIODE	PERIODO	PERIODO
SELECTION 1, ... 20	SELECTION 1, ... 20	ANWAHL 1, ... 20	SELEZIONE 1, ... 20	SELECCION 1, ... 20
DESTINATION	DESTINATION	ZIEL	DESTINAZIO	DESTINO

### CURRENT 4/20mA

EN	FR	GE	IT	SP
APPLY ON	OPERE SUR	KANAL NR	CANALE	CANAL
4mA VALUE	VAL. 4mA	4mA WERT	VALORE 4mA	VALOR 4mA
20mA VALUE	VAL. 20mA	20mA WERT	VALORE 20mA VA	VALOR 20mA

# 11. CONFIGURATION WORKSHEET

---

## TABLE OF CONTENTS

Section	Page
11.1	CONSTRUCTION ..... 11-2
11.2	ANALOG INPUT ..... 11-3
11.3	CHART ..... 11-6
11.4	ALARM ..... 11-8
11.5	DIGITAL ..... 11-11
11.6	MESSAGES ..... 11-13
11.7	PRINTER ..... 11-19
11.8	CHART DOC ..... 11-20
11.9	MMI ..... 11-21
11.10	EVENTS ..... 11-22
11.11	MISCELLANEOUS ..... 11-22
11.12	PERIODIC REPORT ..... 11-23
11.13	CURRENT 4/20 mA ..... 11-23

# 11. CONFIGURATION WORKSHEET

Model number (refer to the Model selection Guide in Section 1)

<table style="width: 100%; border-collapse: collapse;"> <tr> <td style="text-align: center; padding: 5px;">Key Number</td> <td style="text-align: center; padding: 5px;">I</td> <td style="text-align: center; padding: 5px;">II</td> <td style="text-align: center; padding: 5px;">III</td> <td style="text-align: center; padding: 5px;">IV</td> </tr> <tr> <td style="text-align: center; padding: 5px;">D25</td> <td style="text-align: center; padding: 5px;">-</td> <td style="text-align: center; padding: 5px;">-</td> <td style="text-align: center; padding: 5px;">-</td> <td style="text-align: center; padding: 5px;">-</td> </tr> <tr> <td style="text-align: center; padding: 5px;">V</td> <td style="text-align: center; padding: 5px;">-</td> <td style="text-align: center; padding: 5px;">VI</td> <td style="text-align: center; padding: 5px;">-</td> <td style="text-align: center; padding: 5px;">VII</td> </tr> </table>	Key Number	I	II	III	IV	D25	-	-	-	-	V	-	VI	-	VII
Key Number	I	II	III	IV											
D25	-	-	-	-											
V	-	VI	-	VII											

## 11.1 CONSTRUCTION

Voltage Selection					
100 to 240 V <input type="checkbox"/> Special	<table style="width: 100%; border-collapse: collapse;"> <tr> <td style="text-align: right; padding: 5px;">Frequency</td> <td style="padding: 5px;">50 Hz <input type="checkbox"/></td> </tr> <tr> <td></td> <td style="padding: 5px;">60 Hz <input type="checkbox"/></td> </tr> </table>	Frequency	50 Hz <input type="checkbox"/>		60 Hz <input type="checkbox"/>
Frequency	50 Hz <input type="checkbox"/>				
	60 Hz <input type="checkbox"/>				

Number of input Channels	<input style="width: 20px; height: 20px;" type="text"/>										
Relay Output Number	<input style="width: 20px; height: 20px;" type="text"/>										
NB of Digital Inputs	<input style="width: 20px; height: 20px;" type="text"/>										
Door color	Grey <input type="checkbox"/> Black <input type="checkbox"/> Portable Case <input type="checkbox"/>										
Door with Latch	<input type="checkbox"/> with key <input type="checkbox"/> Prompt language Manual <table style="float: right; border-collapse: collapse;"> <tr><td style="padding: 2px 5px;">EN</td><td style="text-align: center; padding: 2px 5px;"><input type="checkbox"/></td></tr> <tr><td style="padding: 2px 5px;">FR</td><td style="text-align: center; padding: 2px 5px;"><input type="checkbox"/></td></tr> <tr><td style="padding: 2px 5px;">GE</td><td style="text-align: center; padding: 2px 5px;"><input type="checkbox"/></td></tr> <tr><td style="padding: 2px 5px;">IT</td><td style="text-align: center; padding: 2px 5px;"><input type="checkbox"/></td></tr> <tr><td style="padding: 2px 5px;">SP</td><td style="text-align: center; padding: 2px 5px;"><input type="checkbox"/></td></tr> </table>	EN	<input type="checkbox"/>	FR	<input type="checkbox"/>	GE	<input type="checkbox"/>	IT	<input type="checkbox"/>	SP	<input type="checkbox"/>
EN	<input type="checkbox"/>										
FR	<input type="checkbox"/>										
GE	<input type="checkbox"/>										
IT	<input type="checkbox"/>										
SP	<input type="checkbox"/>										
Window Glass	<input type="checkbox"/> plastic <input type="checkbox"/>										
Kit of 4 Resistors 46181080-503 To convert mA to Volt	Qty <input style="width: 20px; height: 20px;" type="text"/>										

# 11. CONFIGURATION WORKSHEET

## 11.2 ANALOG INPUT

INPUT #	SENSOR	RANGE	EXT COMP	FILTER	LOW VALUE	HIGH VALUE	STD MATH	DIFF WITH	BURN-OUT	LOW ADJUST	HIGH ADJUST
<i>Customer choice</i>	A	B	C	D	E	F	G	H	I	J	K
1											
2											
3											
4											
5											
6											
7											
8											
9											
10											
11											
12											
13											
14											
15											
16											
17											
18											
19											
20											
21											
22											
23											
24											

S E L E C T I O N S	- T/C Int Comp - T/C Ext Comp - RTD - Transmittance - Linear - Special - No entry	Select the available range (Refer to this manual)	External temperature of the compensation box: 0 to 80°C or channel # used to measure the temperature of the compensation box	Value of the digital filter to damp the analog signal 0 to 99 seconds	Low display value according to the low input range value selected	High display value according to the high input range value selected	Maths apply on analog input - NO OPT MATH - SQUARE ROOT - CHANNEL DIFF	Second CH # used to make the difference	- No burnout - B OUT LOW - B OUT HIGH - FIX LOW - FIX HIGH - FIX NONE	Zero scale adjustment -99 to 99	High scale adjustment -99 to 99
<i>Factory Configuration</i>	<i>T/C Int Comp</i>	<i>J -50/150 C</i>	<i>0.0</i>	<i>5.0</i>	<i>-50.00</i>	<i>150.00</i>	<i>No Opt Math</i>	<i>Analog # i</i>	<i>No Burnout</i>	<i>0.0</i>	<i>0.0</i>

# 11. CONFIGURATION WORKSHEET

INPUT #	SENSOR	RANGE	EXT COMP	FILTER	LOW VALUE	HIGH VALUE	STD MATH	DIFF WITH	BURN-OUT	LOW ADJUST	HIGH ADJUST
<i>Customer choice</i>	A	B	C	D	E	F	G	H	I	J	K
21											
22											
23											
24											
25											
26											
27											
28											
29											
30											
31											
32											
33											
34											
35											
36											
37											
38											
39											
40											

S E L E C T I O N S	- T/C Int Comp - T/C Ext Comp - RTD - Transmittance - Linear - Special - No entry	Select the available range (Refer to this manual)	External temperature of the compensation box: 0 to 80°C or channel # used to measure the temperature of the compensation box	Value of the digital filter to damp the analog signal 0 to 99 seconds	Low display value according to the low input range value selected	High display value according to the high input range value selected	Maths apply on analog input - NO OPT MATH - SQUARE ROOT - CHANNEL DIFF	Second CH # used to make the difference	- No burnout - B OUT LOW - B OUT HIGH - FIX LOW - FIX HIGH - FIX NONE	Zero scale adjustment -99 to 99	High scale adjustment -99 to 99
<i>Factory Configuration</i>	<i>T/C Int Comp</i>	<i>J -50/150 C</i>	<i>0.0</i>	<i>5.0</i>	<i>-50.00</i>	<i>150.00</i>	<i>No Opt Math</i>	<i>Analog # i</i>	<i>No Burnout</i>	<i>0.0</i>	<i>0.0</i>



# 11. CONFIGURATION WORKSHEET

INPUT #	SENSOR	RANGE	EXT COMP	FILTER	LOW VALUE	HIGH VALUE	STD MATH	DIFF WITH	BURN-OUT	LOW ADJUST	HIGH ADJUST
<i>Customer choice</i>	A	B	C	D	E	F	G	H	I	J	K
41											
42											
43											
44											
45											
46											
47											
48											
49											
50											
51											
52											
53											
54											
55											
56											
57											
58											
59											
60											
61											
62											
63											
64											
S E L E C T I O N S	- T/C Int Comp - T/C Ext Comp - RTD - Transmittance - Linear - Special - No entry	Select the available range (Refer to this manual)	External temperature of the compensation box: 0 to 80°C or channel # used to measure the temperature of the compensation box	Value of the digital filter to damp the analog signal 0 to 99 seconds	Low display value according to the low input range value selected	High display value according to the high input range value selected	Maths apply on analog input - NO OPT MATH - SQUARE ROOT - CHANNEL DIFF	Second CH # used to make the difference	- No burnout - B OUT LOW - B OUT HIGH - FIX LOW - FIX HIGH - FIX NONE	Zero scale adjustment -99 to 99	High scale adjustment -99 to 99
<i>Factory Configuration</i>	<i>T/C Int Comp</i>	<i>J -50/150 C</i>	<i>0.0</i>	<i>5.0</i>	<i>-50.00</i>	<i>150.00</i>	<i>No Opt Math</i>	<i>Analog # i</i>	<i>No Burnout</i>	<i>0.0</i>	<i>0.0</i>

# 11. CONFIGURATION WORKSHEET

## 11.3 CHART

CHANNEL #	TRACE	DESTINATION	FORMAT	MIN RANGE 1	MAX RANGE 1	RG 1 COLOR	MIN RANGE 2	MAX RANGE 2	RG 2 COLOR
<i>Customer choice</i>	A	B	C	D	E	F	G	H	I
1									
2									
3									
4									
5									
6									
7									
8									
9									
10									
11									
12									
13									
14									
15									
16									
17									
18									
19									
20									
21									
22									
23									
24									
25									
26									
27									
28									
29									
30									
31									
32									
S E L E C T I O N S	- No trace - Analog # - Comm # - Math #	- On paper - On file - On paper & file	Display and printing format: - no decimal point - 1/10 - 1/100 - 1/1000 - AUTOMATIC	Low chart range value scale 1	High chart range value scale 1	Black Blue Purple Green Brown Red  Thick: Black Blue Purple Green Brown Red	Low chart range value scale 2	High chart range value scale 2	Black Blue Purple Green Brown Red  Thick: Black Blue Purple Green Brown Red
<i>Factory Configuration</i>	Analog #	<i>On paper</i>	<i>Auto-matic</i>	-50.00	+150.00	<i>Black</i>	-50.00	+150.00	<i>Black</i>

# 11. CONFIGURATION WORKSHEET

CHANNEL #	ENG UNIT	TAG NAME	RANGE USED	0% ZONE	100% ZONE	SUB DIV	GROUP DEF
<i>Customer choice</i>	J	K	L	M	N	O	P
1							
2							
3							
4							
5							
6							
7							
8							
9							
10							
11							
12							
13							
14							
15							
16							
17							
18							
19							
20							
21							
22							
23							
24							
25							
26							
27							
28							
29							
30							
31							
32							
S E L E C T I O N S	Display and chart channel  Engineering unit	Display and chart channel name	Chart scale used in normal operation	Left zone position	Right zone position  By step of 1 %	Number of chart scale Subdivisions  1-9 or none	Separate group A or B or A + B of channels to be printed as a group
<i>Factory Configuration</i>			<i>with RG 1</i>	0 %	100 %	<i>No division</i>	<i>No group</i>

# 11. CONFIGURATION WORKSHEET

## 11.4 ALARM

ALARM #	SP VALUE	APPLY ON	ALARM TYPE	HYS-TERE-SIS	OC-CUR-RENCE	DIFF WITH	ACTION	RELAY NUM	ACK-NOW-LEDGE	MSG NUM-BER	MSG COLOR	MSG TYPE	RED IN AL
<i>Customer choice</i>	A	B	C	D	E	F	G	H	I	J	K	L	M
1													
2													
3													
4													
5													
6													
7													
8													
9													
10													
11													
12													
13													
14													
15													
16													
17													
18													
19													
20													

S E L E C T I O N S	Alarm set point in eng. unit value	Analog, Comm and Maths input # on which the alarm is applied	- None - Alarm high - Alarm low - Chg rate H - Chg rate L - Chg rate H, L - Differential	Alarm hysteresis in Eng. unit	Number of alarm SP detection to activate the alarm  0 up to 9	Analog, Comm and Maths input # of the second signal for the alarm differential	- No action - Chg spd/int - Chg range - Print on al - Prt inhibit - Tab sqtrace - Tab sqblank - Prt math log - Chg group B - Chg group AB	Activate the relay #  No or 1 up to 48	Latching the alarm relay	Print the message #  1 up to 64	Color of the alarm message:  Black Blue Purple Green Brown Red	- None - Std message - Message on - Message off - Msg on/off	Switch the trace color in Red  YES NO
<i>Factory Configuration</i>	0.000	Analog # 01	None	0.000	0	Analog # 01	No action	No relay	Disable	Message # 01	Red	None	No

# 11. CONFIGURATION WORKSHEET

ALARM #	SP VALUE	APPLY ON	ALARM TYPE	HYS-TERE-SIS	OCCU-RENCE	DIFF WITH	ACTION	RELAY NUM	ACK-NOW-LEDGE	MSG NUM-BER	MSG COLOR	MSG TYPE	RED IN AL
<i>Customer choice</i>	A	B	C	D	E	F	G	H	I	J	K	L	M
21													
22													
23													
24													
25													
26													
27													
28													
29													
30													
31													
32													
33													
34													
35													
36													
37													
38													
39													
40													

S E L E C T I O N S	Alarm set point in eng. unit value	Analog, Comm and Maths input # on which the alarm is applied	- None - Alarm high - Alarm low - Chg rate H - Chg rate L - Chg rate H, L - Differential	Alarm hysteresis in Eng. unit	Number of alarm SP detection to activate the alarm  0 up to 9	Analog, Comm and Maths input # of the second signal for the alarm differential	- No action - Chg spd/int - Chg range - Print on al - Prt inhibit - Tab sqtrace - Tab sqblank - Prt math log - Chg group B - Chg group AB	Activate the relay #  No or 1 up to 48	Latching the alarm relay	Print the message #  1 up to 64	Color of the alarm message:  Black Blue Purple Green Brown Red	- None - Std message - Message on - Message off - Msg on/off	Switch the trace color in Red  YES NO
<i>Factory Configuration</i>	0.000	Analog # 01	None	0.000	0	Analog # 01	No action	No relay	Disable	Message # 01	Red	None	No

# 11. CONFIGURATION WORKSHEET

ALARM #	SP VALUE	APPLY ON	ALARM TYPE	HYS-TERE-SIS	OCCU-RENCE	DIFF WITH	ACTION	RELAY NUM	ACK-NOW-LEDGE	MSG NUM-BER	MSG COLOR	MSG TYPE	RED IN AL
<i>Customer choice</i>	A	B	C	D	E	F	G	H	I	J	K	L	M
41													
42													
43													
44													
45													
46													
47													
48													
49													
50													
51													
52													
53													
54													
55													
56													
57													
58													
59													
60													
61													
62													
63													
64													

S E L E C T I O N S	Alarm set point in eng. unit value	Analog, Comm and Maths input # on which the alarm is applied	- None - Alarm high - Alarm low - Chg rate H - Chg rate L - Chg rate H, L - Differential	Alarm hysteresis in Eng. unit	Number of alarm SP detection to activate the alarm  0 up to 9	Analog, Comm and Maths input # of the second signal for the alarm differential	- No action - Chg spd/int - Chg range - Print on al - Prt inhibit - Tab sqtrace - Tab sqblank - Prt math log - Chg group B - Chg group AB	Activate the relay #  No or 1 up to 48	Latching the alarm relay	Print the message #  1 up to 64	Color of the alarm message:  Black Blue Purple Green Brown Red	- None - Std message - Message on - Message off - Msg on/off	Switch the trace color in Red  YES NO
<i>Factory Configuration</i>	0.000	Analog #01	None	0.000	0	Analog #01	No action	No relay	Disable	Message #01	Red	None	No

# 11. CONFIGURATION WORKSHEET

## 11.5 DIGITAL

DIGITAL #	TYPE	DIFF WITH	ACTION	RELAY NUM	ACK-NOWLEDGE	MSG NUM	MSG COLOR	MSG TYPE	TRACE	OFF POSITN	ON POSITN	TRACE COLOR	RED IN AL
<i>Customer choice</i>	A	B	C	D	E	F	G	H	I	J	K	L	M
1													
2													
3													
4													
5													
6													
7													
8													
9													
10													
11													
12													
13													
14													
15													
16													
17													
18													
19													
20													
21													
22													
23													
24													

S E L E C T I O N S	- None - Dig closed - Dig opened - Differential	Se- cond Dig input if diffe- rential	- No action - Chg spd/int - Chg range - Print on al - Print inhibit - Tab sqtrace - Tab sqblank - Prt math log - Chg group B - Chg group AB	Activate the relay #  No or 1 up to 48	Latching the alarm relay	Print the mes- sage #  1 to 64	Color of the mes- sage  Black Blue Purple Green Brown Red	- None - Std mes- sage - Mes- sage on - Mes- sage off - Msg on/off	Enable/ Disable event trace	Define the left trace position  1 step = 1%	Define the right trace position  1 step = 1%	Black Blue Purple Green Brown Red	Switch the trace color in Red
<i>Factory Configuration</i>	<i>None</i>	<i>Digital # 01</i>	<i>No action</i>	<i>No relay</i>	<i>Disable</i>	<i>Message # 01</i>	<i>Red</i>	<i>None</i>	<i>Disable</i>	<i>90 %</i>	<i>100 %</i>	<i>Black</i>	<i>No</i>

# 11. CONFIGURATION WORKSHEET

DIGITAL #	TYPE	DIFF WITH	ACTION	RELAY NUM	ACK-NOWLEDGE	MSG NUM	MSG COLOR	MSG TYPE	TRACE	OFF POSITN	ON POSITN	TRACE COLOR	RED IN AL
<i>Customer choice</i>	A	B	C	D	E	F	G	H	I	J	K	L	M
25													
26													
27													
28													
29													
30													
31													
32													
33													
34													
35													
36													
37													
38													
39													
40													
41													
42													
43													
44													
45													
46													
47													
48													

S E L E C T I O N S	- None - Dig closed - Dig opened - Differential	Second Dig input if differential	- No action - Chg spd/int - Chg range - Print on al - Print inhibit - Tab sqtrace - Tab sqblank - Prt math log - Chg group B - Chg group AB	Activate the relay # No or 1 up to 48	Latching the alarm relay	Print the message # 1 to 64	Color of the message Black Blue Purple Green Brown Red	- None - Std message - Message on - Message off - Msg on/off	Enable/Disable event trace	Define the left trace position 1 step = 1%	Define the right trace position 1 step = 1%	Black Blue Purple Green Brown Red	Switch the trace color in Red
<i>Factory Configuration</i>	<i>None</i>	<i>Digital # 01</i>	<i>No action</i>	<i>No relay</i>	<i>Disable</i>	<i>Message # 01</i>	<i>Red</i>	<i>None</i>	<i>Disable</i>	<i>90 %</i>	<i>100 %</i>	<i>Black</i>	<i>No</i>



# 11. CONFIGURATION WORKSHEET

## 11.6 MESSAGES

MSG #	MESSAGE CHARACTERS																									
	1	2	3	4	5	6	7	8	9	10	11	12	13	14	15	16	17	18	19	20	21	22	23	24	25	
1																										
2																										
3																										
4																										
5																										
6																										
7																										
8																										
9																										
10																										
11																										
12																										
13																										
14																										
15																										
16																										
17																										
18																										
19																										
20																										
21																										
22																										
23																										
24																										
25																										
26																										
27																										
28																										
29																										
30																										
31																										
32																										
33																										
34																										
35																										
36																										
37																										
38																										
39																										
40																										
41																										
42																										
43																										
44																										
45																										
46																										
47																										
48																										

Factory Configuration: No Message Configured

# 11. CONFIGURATION WORKSHEET

MSG #	MESSAGE CHARACTERS																									
	26	27	28	29	30	31	32	33	34	35	36	37	38	39	40	41	42	43	44	45	46	47	48	49	50	
1																										
2																										
3																										
4																										
5																										
6																										
7																										
8																										
9																										
10																										
11																										
12																										
13																										
14																										
15																										
16																										
17																										
18																										
19																										
20																										
21																										
22																										
23																										
24																										
25																										
26																										
27																										
28																										
29																										
30																										
31																										
32																										
33																										
34																										
35																										
36																										
37																										
38																										
39																										
40																										
41																										
42																										
43																										
44																										
45																										
46																										
47																										
48																										
Factory Configuration:		No Message Configured																								

# 11. CONFIGURATION WORKSHEET

MSG #	MESSAGE CHARACTERS													
	51	52	53	54	55	56	57	58	59	60	61	62	63	64
1														
2														
3														
4														
5														
6														
7														
8														
9														
10														
11														
12														
13														
14														
15														
16														
17														
18														
19														
20														
21														
22														
23														
24														
25														
26														
27														
28														
29														
30														
31														
32														
<i>Factory Configuration: No Message Configured</i>														

# 11. CONFIGURATION WORKSHEET

MSG #	MESSAGE CHARACTERS																									
	1	2	3	4	5	6	7	8	9	10	11	12	13	14	15	16	17	18	19	20	21	22	23	24	25	
33																										
34																										
35																										
36																										
37																										
38																										
39																										
40																										
41																										
42																										
43																										
44																										
45																										
46																										
47																										
48																										
49																										
50																										
51																										
52																										
53																										
54																										
55																										
56																										
57																										
58																										
59																										
60																										
61																										
62																										
63																										
64																										

Factory Configuration: No Message Configured

# 11. CONFIGURATION WORKSHEET

MSG #	MESSAGE CHARACTERS																									
	26	27	28	29	30	31	32	33	34	35	36	37	38	39	40	41	42	43	44	45	46	47	48	49	50	
33																										
34																										
35																										
36																										
37																										
38																										
39																										
40																										
41																										
42																										
43																										
44																										
45																										
46																										
47																										
48																										
49																										
50																										
51																										
52																										
53																										
54																										
55																										
56																										
57																										
58																										
59																										
60																										
61																										
62																										
63																										
64																										
Factory Configuration:		No Message Configured																								

# 11. CONFIGURATION WORKSHEET

MSG #	MESSAGE CHARACTERS													
	51	52	53	54	55	56	57	58	59	60	61	62	63	64
33														
34														
35														
36														
37														
38														
39														
40														
41														
42														
43														
44														
45														
46														
47														
48														
49														
50														
51														
52														
53														
54														
55														
56														
57														
58														
59														
60														
61														
62														
63														
64														
<i>Factory Configuration: No Message Configured</i>														

# 11. CONFIGURATION WORKSHEET

## 11.7 PRINTER

	SPEED UNIT	SPEED 1	SPEED 2	INTERVAL 1	INTERVAL 2	SP/INT USED	RECORD MODE	PRINT MODE	CHART LG
<i>Customer choice</i>									
<b>S E L E C T I O N S</b>	Chart speed unit	Value of the chart speed 1	Value of the chart speed 2	Tabular Prints interval 1	Tabular Prints interval 2	Speed/int in normal operation	- Inhibit - Print	- Trend - Tabular	Chart length to actuate the event alarm
	mm/h inch/h  0.04	1 to 5000 mm/h  to 196.86 inch/h	1 to 5000 mm/h  0.04 to 196.86 inch/h	1 to 1440 mn	1 to 1440 mn				0 to 35000 mm
<i>Factory Conf.</i>	<i>mm/h (EU) inch/h (US)</i>	<i>60 mm/h 2 inch/h</i>	<i>120 mm/h 5 inch/h</i>	<i>10</i>	<i>1</i>	<i>Speed 1</i>	<i>Print</i>	<i>Trend</i>	<i>35000</i>

# 11. CONFIGURATION WORKSHEET

## 11.8 CHART DOC

	PRT INTRVAL	INFORMATION # 1	INFORMATION # 2	INFORMATION # 3	INFORMATION # 4	INFORMATION # 5	INFORMATION # 6
<i>Customer choice</i>							
<b>S E L E C T I O N S</b>	Time between 2 consecutive printed information # 1 to 10  1 to 1440 mn	- No information - Message # - Range # - Next range - Blank - Snap shot trace - Snap shot analog - Snap shot math - Snap shot logic	- No information - Message # - Range # - Next range - Blank - Snap shot trace - Snap shot analog - Snap shot math - Snap shot logic	- No information - Message # - Range # - Next range - Blank - Snap shot trace - Snap shot analog - Snap shot math - Snap shot logic	- No information - Message # - Range # - Next range - Blank - Snap shot trace - Snap shot analog - Snap shot math - Snap shot logic	- No information - Message # - Range # - Next range - Blank - Snap shot trace - Snap shot analog - Snap shot math - Snap shot logic	- No information - Message # - Range # - Next range - Blank - Snap shot trace - Snap shot analog - Snap shot math - Snap shot logic
<i>Factory Conf.</i>	60 mn	Next Range	Snap shot trace	No information	No information	No information	No information

	INFORMATION # 7	INFORMATION # 8	INFORMATION # 9	INFORMATION # 10	TRACE REF	FUNCT MSG
<i>Customer choice</i>						
<b>S E L E C T I O N S</b>	- No information - Message # - Range # - Next range - Blank - Snap shot trace - Snap shot analog - Snap shot math - Snap shot logic	- No information - Message # - Range # - Next range - Blank - Snap shot trace - Snap shot analog - Snap shot math - Snap shot logic	- No information - Message # - Range # - Next range - Blank - Snap shot trace - Snap shot analog - Snap shot math - Snap shot logic	- No information - Message # - Range # - Next range - Blank - Snap shot trace - Snap shot analog - Snap shot math - Snap shot logic	- Number - Number & tag	Functional Messages  Enable Disable
<i>Factory Conf.</i>	No information	No information	No information	No information	Number	Enable



# 11. CONFIGURATION WORKSHEET

## 11.9 MMI

	HOLD KEY	DISPLAY KEY	PRINT KEY	RESET KEY	ACK KEY	DISPLAY HI	DISPLAY LO
<i>Customer choice</i>							
S E L E C T I O N S	Hold the display	Modify the display indication	Make printing action	To reset maths functions or alarm occurrences	To acknowledge the alarm	<ul style="list-style-type: none"> <li>- Analog inputs</li> <li>- 2 PVs trace</li> <li>- Maths results</li> <li>- Comm results</li> <li>- Alarm status</li> <li>- Speed in use</li> <li>- Date &amp; time</li> <li>- Trace &amp; tag</li> <li>- Trace in AL</li> <li>- Logic states</li> </ul>	<ul style="list-style-type: none"> <li>- Analog inputs</li> <li>- 2 PVs trace</li> <li>- Comm results</li> <li>- Alarm status</li> <li>- Speed in use</li> <li>- Date &amp; time</li> </ul>
	Enable Disable	Enable Disable	Enable Disable	Enable Disable	Enable Disable		
<i>Factory Conf.</i>	<i>Enable</i>	<i>Enable</i>	<i>Enable</i>	<i>Enable</i>	<i>Enable</i>	<i>Analog inputs</i>	<i>Analog inputs</i>

	BRIGHT	F1 KEY	F2 KEY
<i>Customer choice</i>			
S E L E C T I O N S	<ul style="list-style-type: none"> <li>- OFF (0%)</li> <li>- &gt;&gt; (20%)</li> <li>- MEDIUM (40%)</li> <li>- &gt;&gt; (60%)</li> <li>- &gt;&gt; (80%)</li> <li>- HIGH (100%)</li> </ul>	To configure the action of the key F1 <ul style="list-style-type: none"> <li>- UNUSED</li> <li>- INHIBIT /PRINT</li> <li>- RESET</li> <li>PAPER LENG</li> <li>- CHANGE</li> <li>SPEED</li> <li>- PRINT DATE &amp; TIME</li> <li>- SNAP SHOT</li> <li>TRACE</li> <li>- CHART</li> <li>ADVANCE</li> <li>- CHG</li> <li>GROUP A</li> <li>- CHG</li> <li>GROUP B</li> <li>- CHG</li> <li>GROUP A+B</li> <li>- SNAP SHOT</li> <li>LOGIC</li> <li>- SNAP SHOT</li> <li>MATH</li> <li>- START /</li> <li>STOP ARCH</li> <li>- REMOVE</li> <li>PCMCIA</li> </ul>	To configure the action of the key F2 <ul style="list-style-type: none"> <li>- UNUSED</li> <li>- INHIBIT- /PRINT</li> <li>- RESET</li> <li>PAPER LENG</li> <li>- CHANGE</li> <li>SPEED</li> <li>- PRINT DATE &amp; TIME</li> <li>- SNAP SHOT</li> <li>TRACE</li> <li>- CHART</li> <li>ADVANCE</li> <li>- CHG</li> <li>GROUP A</li> <li>- CHG</li> <li>GROUP B</li> <li>- CHG</li> <li>GROUP A+B</li> <li>- SNAP SHOT</li> <li>LOGIC</li> <li>- SNAP SHOT</li> <li>MATH</li> <li>- START /</li> <li>STOP ARCH</li> <li>- REMOVE</li> <li>PCMCIA</li> </ul>
	<i>Factory Conf.</i>	<i>80 %</i>	<i>Inhibit/ Print</i>

# 11. CONFIGURATION WORKSHEET

## 11.10 EVENTS

	EVENT TYPE	RELAY NUM	DISPLAY
<i>Customer choice</i>			
S E L E C T I O N S	EV 01 – No paper EV 02 – End paper EV 03 - Battery fail EV 04 – One alarm ON EV 05 - Burnout EV 06 - Shedtime EV 07- PCMCIA Event	To actuate a relay output  # 1 to 36	To display an alarm event  Enable Disable
<i>Factory Conf.</i>	<i>EV 01 to EV 07</i>	<i>No relay</i>	<i>Enable</i>

## 11.11 MISCELLANEOUS

	TIME	DATE	LANGUA GE	INTERFA CE	IDENTI F #	FREQUEN CY	PASSW ORD 1	PASSW ORD 2	OPTIO NS
<i>Customer choice</i>									
S E L E C T I O N S	Set the real time clock  Hour Minute	Set the date  Day Month Year	- English - French - German - Italian - Spanish	- Jack - PCMCIA	Set the ID # of the unit  1 to 99	50 Hz 60 Hz	Limited configuration access	Full configuration access	No package Math
<i>Factory Conf.</i>	<i>(Real time)</i>	<i>(Real time)</i>	<i>English</i>	<i>Jack</i>	<i>1</i>	<i>50 Hz (EU) 60 Hz (US)</i>	<i>None</i>	<i>None</i>	<i>No package</i>

# 11. CONFIGURATION WORKSHEET

## 11.12 PERIODIC REPORT

	SYNCHRO AT	PERIOD	SELECTION 1, ... 20	DESTINATION
<i>Customer choice</i>	A	B	C	D
S E L E C T I O N S	[0 ... 23] hours	hours and cents of hours	TRACE # MATH # NONE	ON PAPER
	[0 ... 59] minutes	[0.25 ... 720] hours		
<i>Factory Conf.</i>	00h00	0.00	NONE	ON PAPER



## 11.13 CURRENT 4/20 mA

	APPLY ON	4mA VALUE	20mA VALUE
<i>Customer choice</i>	A	B	C
S E L E C T I O N S	Defines the channel from which the current output will be calculated.	Determines the value associated with 4 mA.	Determines the value associated with 20 mA.
	NONE ANALOG # MATH # COMM #		
<i>Factory Conf.</i>	NONE	-50.000	150.000

## ***11. CONFIGURATION WORKSHEET***

---

**SIKKERHEDSKRAV**

	For at undgå elektrisk stød med mulighed for personskade, skal alle sikkerhedsbestemmelser i denne manual følges nøje.
	Beskyttende jordterminal. Terminalen er forberedt for og skal forbindes til beskyttelses-jordledning i henhold til stærkstrømsbekendtgørelsen (DK).

- Hvis udstyret ikke bruges som specificeret i manualen, kan den beskyttelse udstyret yder blive nedsat eller forsvinde.
- Erstat kun komponenter som udtrykkeligt er specificeret som udskiftelige i manualen.
- Alle ledningsforbindelser skal følge stærkstrømsbekendtgørelsen (DK) og udføres af autoriseret erfarent personel.
- Den beskyttende jordterminal skal forbindes først af alle forbindelser (og fjernes som den sidste).
- Det anbefales jvf. stærkstrømsbekendtgørelsen, at der installeres en afbryder til forsyningsspændingen nær udstyret.
- Hvis der installeres en extern sikring til skriveren, skal denne svare fuldstændig til skrivers egen sikring (type) og ligeså sikringsholder.

**UDSTYRS SPECIFIKATIONER**

Strømforsyning: 100 til 240 V AC/DC

Frekvens: 50/60 Hz

Effektforbrug: 100 VA max.

**OMGIVELSE SPECIFIKATIONER**

Placer ikke udstyret i nærheden af brandbare væsker eller dampe.

<b>Fugtighed</b>	Rullepapir	10 - 90 % RH ikke kondenserende 15 - 80 % RH ikke kondenserende
<b>Temperatur</b>	Drift	Rullepapir: 0 til 50°C (32 til 122°F) Foldepapir: 0 til 40°C (32 til 104°F)
	Opbevaring	-40 til 70°C (-40 til 158°F)
<b>Vibrationer</b>	Frekvens	10 til 60 Hz, amplitude 0.14 mm 60 til 150 Hz, acceleration 1 g

**UDSTYRS INSTALLATION      INSTRUKTION**

Skriveren skal monteres i en tavle for at forhindre udstyret. adgang til bagterminaler.  
(Maksimal tavletykkelse 40 mm)

**FOR RENGØRING**



Brug kun en tår bomuldsklud til rengøring af

**UDSKIFTNING AF SIKRING**

Sikring: For at forebygge brand, vær sikker på at sikringen opfylder kravene til strøm, spænding og karakteristik.

Sluk for spændingen før sikringen udskiftes. Brug ikke en sikring af anden type.

**TURVALLISUUSMÄÄRÄYKSET**

	Noudata tämän ohjeen kaikkia turvaohjeita välttääksesi sähkötapaturman vaaraa.
	Suojamaaliitin. Kytke maadoitusjohdin tähän liittimeen.

- Jos laitetta käytetään olosuhteissa, joihin sitä ei ole suunniteltu, käyttöturvallisuus voi heikentyä.
- Älä vaihda mitään komponenttia tai osaa, jota valmistaja ei ole määritellyt käyttäjän vaihdettavaksi.
- Asennus ja johdotus on tehtävä paikallisten varmuusmääräysten mukaisesti valtuutetun sähköasentajan toimesta.
- Ensimmäiseksi on kytkettävä suojamaa-liitin (ja viimeiseksi irroittettava).
- Laitteen läheisyyteen suositellaan asennettavaksi verkkokytkin.
- Syöttöjohdon sulake tulee mitoittaa syötettävien laitteiden aiheuttaman kuormituksen mukaisesti.
- 

**LAITTEEN VAATIMUKSET**

Syöttöjännite: 100 ... 240 V AC/DC

Taajuus: 50/60 Hz

Tehonkulutus: 100 VA max.

**KÄYTTÖOLOSUHTEET**

Älä käytä laitetta paikassa jossa on syttyviä nesteitä tai kaasuja, koska laitteen käyttö aiheuttaa räjähdysvaaran.

<b>Kosteus</b>	Rulla	10 ... 90 % RH non condensing
	Laskostuva	15 ... 80 % RH non condensing
<b>Lämpötila</b>	Käyttö	Rulla: 0 ... 50 ast. C (32 ... 122 ast. F) Laskostuva: 0 ... 40 ast. C (32 ... 104 ast. F)
	Varastointi	-40 ... 70 ast. C (-40 ... 158 ast. F)
	Tärinä	Taajuus

**LAITTEEN ASENNUS PUHDISTUSOHJEET**



Piirturi on asennettava paneeliin siten, että peräliittimille jää riittävästi tilaa. puhdistukseen. (Paneelin maksimi paksuus 40 mm)

Käytä vain kuivaa puuvillakangasta laitteen

**KULUTUSOSIEN VAIHTAMINEN**

Käytä aina oikean tyyppistä sulaketta (virta, jännite, tyyppi). Katkaise syöttöjännite laitteesta ennen sulakkeen vaihtoa. Älä käytä ohjeista poikkeavaa sulaketta tai oikosulje sulakepesää.

**SÄKERHETSFÖRESKRIFTER**

	För att reducera riskerna av elektriska chocker som kan orsaka personskador, följ alla säkerhetsföreskrifter i denna dokumentation.
	Anslutning av skyddsjord. Avsedd för anslutning av elsystemets skyddsjordsledare.

- Om utrustningen används på ett sådant sätt, att det inte innefattas av tillverkarens specifikation, kan de inbyggda säkerhetsfunktionerna äventyras.
- Ersätt aldrig någon komponent (eller del) som inte är specificerad som ersättningsbar av tillverkaren.
- All ledningsdragning måste utföras i enlighet med lokala bestämmelser och skall utföras av behörig personal med erfarenhet av sådant arbete.
- Skyddsjordsanslutningen skall anslutas före alla andra anslutningar (och losskopplas sist).
- En strömbrytare för nätströmmen rekommenderas.
- Om en extern säkring används för att skydda skrivaren skall denna säkring motsvara skrivarens säkring.

**STRÖMFÖRSÖRJNING**

Spänning: 100 till 240 V AC/DC

Frekvens: 50/60 Hz

Effekt: 100 VA max.

**OMGIVNINGSVILLKOR**

Använd ej instrumentet i närhet av brännbara vätskor eller gaser. Användandet av instrumentet i sådan miljö är en direkt säkerhetsrisk.

<b>Fuktighet</b>	Rullat papper	10 till 90 % RH ej kondenserande
	Veckat papper	15 till 80 % RH ej kondenserande
<b>Temperatur</b>	Omgivande	Rullat papper: 0 till 50°C (32 till 122°F)
		Veckat papper: 0 till 40°C (32 till 104°F)
<b>Vibrationer</b>	Lagring	-40 till 70°C (-40 till 158°F)
	Frekvens	10 till 60 Hz, amplitud 0.14 mm 60 till 150 Hz, acceleration 1 g

**INSTALLATION**

Instrumentet skall monteras i en panel eller i en låda för att undvika att personalen kommer i beröring med bakre inkopplingsplintar.  
(Max. paneltjocklek 40 mm).



**RENGÖRINGSINSTRUKTION**

\_\_\_\_\_  
Använd endast en torr trasa för att rengöra instrumentet.

**BYTE AV SÄKRING**

För att undvika gnistbildning eller eldsvåda använd endast specificerad säkring (ström, spänning, typ). Före säkringsbyte, slå av nätspänningen till instrumentet. Sätt i ny säkring. Kortslut ej säkringshållaren.

## NORME DI SICUREZZA

	Per ridurre i rischi di scariche elettriche che potrebbero causare alle persone, seguire tutte le precauzioni circa la sicurezza indicate in questa documentazione.
	Terminale di protezione verso terra. Previsto per il collegamento del conduttore di protezione verso terra del sistema di alimentazione.

- Se lo strumento viene utilizzato in modo diverso dalla specifica del costruttore, la protezione fornita dallo strumento può essere diversa.
- Non sostituire alcun componente (o parte) non specificato esplicitamente come ricambio dal vostro fornitore.
- Tutti i cablaggi devono essere in accordo con i regolamenti locali e devono essere eseguiti da personale esperto ed autorizzato.
- Il terminale di massa deve essere collegato prima di ogni altro filo (e scollegato per ultimo).
- E' raccomandato montare un interruttore per l'alimentazione principale vicino allo strumento.
- Se viene usato un fusibile esterno per proteggere il circuito elettrico del registratore, il fusibile deve essere adatto alla portata richiesta e al tipo del porta fusibile.

### ALIMENTAZIONE APPARECCHIATURA

Tensione di alimentazione: da 100 a 240 V CA/CC

Frequenza: 50/60 Hz

Consumo: 100 VA max.

### CONDIZIONI AMBIENTALI

Non utilizzare lo strumento in presenza di liquido o vapori infiammabili. L'uso di qualsiasi strumento elettrico in queste condizioni ambientali costituisce un pericolo alla sicurezza.

<b>Umidità</b>	Carta a rotolo	da 10 a 90 % UR non condensata
	Carta a pacchetto	da 15 a 80 % UR non condensata
<b>Temperatura</b>	Ambiente	Carta a rotoloda: 0 a 50 Gradi C (da 32 a 122 Gradi F) Carta a pacchetto: 0 a 40 Gradi C (da 32 a 104 Gradi F)
	Stoccaggio	da -40 a 70 Gradi C (da -40 a 158 Gradi F)
<b>Vibrazioni</b>	Frequenza	da 10 a 60 Hz, ampiezza 0.14 mm
		da 60 a 150 Hz, accelerazione 1 g

### INSTALLAZIONE STRUMENTO

Il registratore deve essere montato sul quadro  
cotone per la pulizia dello  
senza limitare l'accesso dell'operatore ai terminali  
posteriori. (massimo spessore del quadro 40 mm)

### ISTRUZIONI

### PER LA PULIZIA



Usare solo uno straccio pulito in  
strumento.

### SOSTITUZIONE DEI MATERIALI DI CONSUMO

Fusibile: Per evitare incendi, assicurarsi di usare il fusibile secondo lo standard specificato (tipo, tensione, corrente). Prima di sostituire il fusibile, spegnere lo strumento e scollegare l'alimentazione. Non usare un fusibile differente o cortocircuitare il porta fusibile.



**NORMAS DE SEGURIDAD**

	<p>Para reducir el riesgo de choque eléctrico el cual podría causar lesiones personales, seguir todas las indicaciones de este documento.</p>
	<p>Terminal de tierra de protección. Proporcionado para la conexión de la tierra de protección del conductor del sistema de alimentación.</p>

- Si el equipo es utilizado de forma no especificada por el fabricante, la protección suministrada con el mismo podría resultar dañada.
- No reemplazar ningún componente (o parte) no explícitamente especificado por el suministrador.
- Todo el cableado debe realizarse de acuerdo con las normas eléctricas locales y debe ser realizado por personal experimentado.
- El terminal de tierra debe ser conectado antes que cualquier otro cable y desconectado el último.
- Se recomienda la instalación de un interruptor de la alimentación principal, cerca del equipo.
- Si se utiliza un fusible externo para proteger el circuito eléctrico del registrador, deben tenerse en cuenta tanto las características del fusible del registrador (tipo de fusible) como las del portafusible).

**DATOS ELECTRICOS DEL EQUIPO**

Tensión de alimentación: 100 a 240 V AC/DC

Frecuencia: 50/60 Hz

Corriente: 100 VA max.

**CONDICIONES AMBIENTALES**

No operar con el instrumento en presencia de líquidos o gases inflamables. La operación de cualquier equipo eléctrico en tal ambiente constituye un riesgo contra la seguridad.

<b>Humedad</b>	Rollo	10 a 90 % RH sin condensados
	Plegado	15 a 80 % RH sin condensados
<b>Temperatura</b>	Ambiente	Rollo: 0 a 50°C (32 a 122°F) Dlegado: 0 a 40°C (32 a 104°F)
	Almacenamiento	-40 a 70°C (-40 a 158°F)
<b>Vibraciones</b>	Frecuencia	10 a 60 Hz, amplitud 0.14 mm
		60 a 150 Hz, aceleración 1 g

**INSTALACION DEL EQUIPO    INSTRUCCIONES**

El registrador debe ser montado en un panel para algodón para limitar al operador el acceso a los terminales traseros (espesor máximo del panel 40 mm).



**DE LIMPIEZA**

Utilizar únicamente un paño seco de limpiar la unidad.

**REPOSICION DE CONSUMIBLES**

Fusible: Para prevenir una posible ignición, asegurarse de utilizar fusibles normalizados (según tipo de corriente-tensión). Antes de reemplazar el fusible, interrumpir la alimentación. No utilizar un fusible diferente o cortocircuitar el soporte del mismo.

## ΑΠΑΙΤΗΣΕΙΣ ΑΣΦΑΛΕΙΑΣ

	ΓΙΑ ΝΑ ΜΕΙΩΘΕΙ Ο ΚΙΝΔΥΝΟΣ ΗΛΕΚΤΡΟΠΛΗΞΙΑΣ Η ΟΠΟΙΑ ΜΠΟΡΕΙ ΝΑ ΠΡΟΚΑΛΕΣΕΙ ΤΡΑΥΜΑΤΙΣΜΟ, ΑΚΟΛΟΥΘΕΙΣΤΕ, ΟΛΕΣ ΤΙΣ ΟΔΗΓΙΕΣ ΑΣΦΑΛΕΙΑΣ ΠΟΥ ΠΑΡΑΤΙΘΕΝΤΑΙ ΣΕ ΑΥΤΟ ΤΟ ΦΥΛΛΑΔΙΟ.
	ΠΡΟΣΤΑΤΕΥΤΙΚΗ ΓΕΙΩΣΗ. ΠΑΡΕΧΕΤΑΙ ΓΙΑ ΤΗΝ ΣΥΝΔΕΣΗ ΜΕ ΤΟ ΣΥΣΤΗΜΑ ΓΕΙΩΣΗΣ ΤΗΣ ΕΓΚΑΤΑΣΤΑΣΗΣ.

- ΑΝ Η ΣΥΣΚΕΥΗ ΧΡΗΣΙΜΟΠΟΙΗΘΕΙ ΜΕ ΤΡΟΠΟ ΠΟΥ ΔΕΝ ΣΥΜΦΩΝΕΙ ΜΕ ΤΙΣ ΟΔΗΓΙΕΣ ΤΟΥ ΚΑΤΑΣΚΕΨΑΣΤΗ ΠΙΘΑΝΟΝ ΝΑ ΜΕΙΩΘΕΙ Η ΠΡΟΣΤΑΣΙΑ ΠΟΥ ΠΑΡΕΧΕΙ.
- Α ΜΗΝ ΑΝΤΙΚΑΘΙΣΤΑΤΑΙ ΚΑΝΕΝΑ ΕΞΑΡΤΗΜΑ ΗΉ ΤΜΗΜΑ ΤΟΥ ΟΡΓΑΝΟΥ ΠΟΥ ΔΕΝ ΑΝΑΦΕΡΕΤΑΙ Σ ΑΦΩΣ ΑΠΟ ΤΟΝ ΚΑΤΑΣΚΕΥΑΣΤΗ ΩΣ ΑΝΤΑΛΛΑΞΙΜΟ.
- ΟΛΕΣ ΟΙ ΚΑΛΩΔΙΩΣΕΙΣ ΠΡΕΠΕΙ ΝΑ ΕΙΝΑΙ ΣΥΜΦΩΝΕΣ ΜΕ ΤΗΝ ΤΟΠΙΚΗ ΝΟΜΟΘΕΣΙΑ ΚΑΙ Η ΕΓΚΑΤΑΣΤΑΣΗ ΤΟΥΣ ΠΡΕΠΕΙ ΝΑ ΓΙΝΕΙ ΑΠΟ ΕΙΔΙΚΕΥΜΕΝΟ ΚΑΙ ΕΜΠΕΙΡΟ ΠΡΟΣΩΠΙΚΟ.
- Η ΓΕΙΩΣΗ ΠΡΕΠΕΙ ΝΑ ΣΥΝΔΕΘΕΙ ΠΡΙΝ ΑΠΟ ΟΠΟΙΟΔΗΠΟΤΕ ΑΛΛΗ ΚΑΛΩΔΙΩΣΗ, ΚΑΙ ΤΕΛΕΥΤΑΙΑ ΚΑΤΑ ΤΗΝ ΑΠΟΣΥΝΔΕΣΗ.
- ΕΝΑΣ ΔΙΑΚΟΠΤΗΣ ΤΗΣ ΚΥΡΙΑΣ ΠΑΡΟΧΗΣ ΣΥΝΙΣΤΑΤΑΙ ΚΟΝΤΑ ΣΤΟ ΟΡΓΑΝΟ.
- ΕΑΝ ΧΡΗΣΙΜΟΠΟΙΗΘΕΙ ΕΞΩΤΕΡΙΚΗ ΑΣΦΑΛΕΙΑ ΠΡΟΣΤΑΣΙΑΣ ΓΙΑ ΤΟ ΗΛΕΚΤΡΙΚΟ ΚΥΚΛΩΜΑ ΣΤΟ ΚΑΤΑΓΡΑΦΙΚΟ, Η ΑΣΦΑΛΕΙΑ ΚΑΙ Η ΑΣΦΑΛΕΙΟΦΗΚΗ ΠΡΕΠΕΙ ΝΑ ΕΙΝΑΙ ΑΝΤΙΣΤΕΙΧΗΣ ΙΣΧΥΟΣ.

**ΤΕΧΝΙΚΑ ΣΤΟΙΧΕΙΑ ΟΡΓΑΝΟΥ**

ΤΡΟΦΟΔΟΣΙΑ : 100 – 240 V ac/dc

ΣΥΧΝΟΤΗΤΑ : 50/60 Hz

ΙΣΧΥΣ : 100 VA ΜΕΓΙΣΤΗ

**ΣΥΝΘΗΚΕΣ ΠΕΡΙΒΑΛΛΟΝΤΟΣ**

ΝΑ ΜΗΝ ΧΡΗΣΙΜΟΠΟΙΕΙΤΑΙ ΤΟ ΟΡΓΑΝΟ ΣΕ ΧΩΡΟΥΣ ΜΕ ΠΑΡΟΥΣΙΑ ΕΥΦΛΕΚΤΩΝ ΥΓΡΩΝ Η ΑΤΜΩΝ. ΧΡΗΣΗ ΟΠΟΙΟΥΔΗΠΟΤΕ ΗΛΕΚΤΡΙΚΟΥ ΟΡΓΑΝΟΥ ΣΕ ΤΕΤΟΙΟ ΠΕΡΙΒΑΛΛΟΝ ΑΠΟΤΕΛΕΙ ΚΙΝΔΥΝΟ ΑΤΥΧΗΜΑΤΟΣ.

<b>ΥΓΡΑΣΙΑ</b>	ΧΑΡΤΙ ΡΟΛΛΟ	10 – 90 % RH ΜΗ ΣΥΜΠΥΚΝΩΜΕΝΗ
	ΧΑΡΤΙ ΔΙΠΛΩΜΕΝΟ	15 – 80 % RH ΜΗ ΣΥΜΠΥΚΝΩΜΕΝΗ
<b>ΘΕΡΜΟΚΡΑΣΙΑ</b>	ΠΕΡΙΒΑΛΛΟΝΤΟΣ	ΧΑΡΤΙ ΡΟΛΛΟ: 0 / 50 DEG C (32 / 122 DEG F)
	ΑΠΟΘΗΚΕΥΣΗΣ	ΧΑΡΤΙ ΔΙΠΛΩΜΕΝΟ: 0 / 40 DEG C (32 / 104 DEG F) – 40 / 70 DEG C ( – 40 / 158 DEG F)
<b>ΤΑΛΑΝΤΩΣΗ</b>	ΣΥΧΝΟΤΗΤΑ	10 – 60 Hz, ΜΕΓΕΘΟΣ 0.14 mm
		60 – 150 Hz, ΕΠΙΤΑΧΥΝΣΗ 1 g

**ΤΟΠΟΘΕΤΗΣΗ ΜΗΧΑΝΗΜΑΤΟΣ**

ΤΟ ΚΑΤΑΓΡΑΦΙΚΟ ΟΡΓΑΝΟ ΠΡΕΠΕΙ ΝΑ ΤΟΠΟΘΕΤΗΘΕΙ ΣΤΗΝ ΠΡΟΣΟΧΗ ΤΟΥ ΠΙΝΑΚΑ, ΕΤΣΙ ΩΣΤΕ ΝΑ ΜΗΝ ΜΠΟΡΕΙ Ο ΧΕΙΡΙΣΤΗΣ ΝΑ ΕΧΕΙ ΠΡΟΣΒΑΣΗ ΣΤΟ ΠΙΣΩ ΜΕΡΟΣ. ΜΕΓΙΣΤΟ ΠΑΧΟΣ ΠΙΝΑΚΟΣ 40 mm.



**ΟΔΗΓΙΕΣ ΚΑΘΑΡΙΣΜΟΥ**

ΧΡΗΣΙΜΟΠΟΙΗΣΤΕ ΜΟΝΟ ΕΝΑ ΣΤΕΓΝΟ ΒΑΜΒΑΚΕΡΟΥ ΦΑΣΜΑ ΓΙΑ ΤΟΝ ΚΑΘΑΡΙΣΜΟ ΤΟΥ ΟΡΓΑΝΟΥ

**ΑΝΤΙΚΑΤΑΣΤΑΣΗ ΑΝΑΛΩΣΙΜΟΥ ΥΛΙΚΟΥ**

ΑΣΦΑΛΕΙΑ: ΠΡΟΣ ΑΠΟΦΥΓΗ ΠΥΡΚΑΙΑΣ Η ΑΣΦΑΛΕΙΑ ΘΑ ΠΡΕΠΕΙ ΝΑ ΑΝΤΙΚΑΘΙΣΤΑΤΑΙ ΜΕ ΝΕΑ, ΒΑΣΗ ΤΩΝ ΠΡΟΤΕΙΝΟΜΕΝΩΝ ΠΡΟΔΙΑΓΡΑΦΩΝ (ΤΑΣΗ, ΕΝΤΑΣΗ, ΤΥΠΟΣ). ΠΡΙΝ ΑΠΟ ΤΗΝ ΑΝΤΙΚΑΤΑΣΤΑΣΗ ΝΑ ΔΙΑΚΟΠΤΕΤΑΙ Η ΠΑΡΟΧΗ ΤΑΣΗΣ ΗΉ ΝΑ ΑΠΟΣΥΝΔΕΕΤΑΙ Η ΚΑΛΩΔΙΩΣΗ ΠΑΡΟΧΗΣ. ΝΑ ΜΗΝ ΧΡΗΣΙΜΟΠΟΙΗΤΑΙ ΑΣΦΑΛΕΙΑ ΔΙΑΦΟΡΕΤΙΚΗ ΑΠΟ ΤΗΝ ΠΡΟΤΕΙΝΟΜΕΝΗ, ΚΑΙ ΝΑ ΜΗΝ ΒΡΑΧΥΚΥΚΛΩΝΕΤΑΙ Η ΑΣΦΑΛΕΙΟΦΗΚΗ.

## VEILIGHEIDSVEREISTEN

	Ter vermindering van het gevaar van elektrische schokken die lichamelijk letsel kunnen veroorzaken, dient u alle veiligheidsaanwijzingen in dit document te volgen.
	Beschermende aarde-aansluiting. Bestemd voor aansluiting van de aardingsdraad van de voeding.

- Indien de apparatuur wordt gebruikt anders dan door de fabrikant gespecificeerd, kan de bescherming, die de apparatuur biedt ongedaan worden gemaakt.
- Alleen die onderdelen mogen worden vervangen die door de fabrikant als uitwisselbaar zijn aangemerkt.
- Alle bedrading moet in overeenstemming zijn met de lokale elektriciteitseisen en moet aangelegd worden door geautoriseerd, ervaren personeel.
- De aardingsdraad moet worden aangesloten vóórdat alle andere bedrading wordt aangesloten (en als laatste worden verbroken).
- Het verdient aanbeveling een netschakelaar aan te brengen vlakbij het instrument.
- Indien een externe zekering wordt toegepast om de elektrische stroomkring naar de recorder te beschermen, moet deze zekering voldoen aan de specificaties die gelden voor zowel de zekering van de recorder (type zekering) als die voor de zekeringhouder.

### Apparatuur voorwaarden

Aansluitspanning: 100 tot 240 V AC/DC

Frequentie: 50/60 Hz

Toegestane belasting: 100 VA max.

### Omgevingscondities

Gebruik het instrument niet in de aanwezigheid van ontvlambare vloeistoffen of dampen. Het gebruik van elk elektrisch instrument in een dergelijke omgeving vormt een gevaar voor uw veiligheid.

<b>Relatieve vochtigheid</b>	Rol	10 tot 90 % RH niet condenserend
	Vouwkaart	15 tot 80 % RH niet condenserend
<b>Temperatuur</b>	Omgevingstemp.	Rol: 0 tot 50°C (32 tot 122°F)
		Vouwkaart: 0 tot 40°C (32 tot 104°F)
	Opslag	-40 tot 70°C (-40 tot 158°F)
<b>Trillingen</b>	Frequentie	10 tot 60 Hz, amplitude 0.14 mm
		60 tot 150 Hz, versnelling 1 g

### Montage van de apparatuur      **Schoonmaken**



De recorder moet worden gemonteerd in een paneel om de toegankelijkheid tot de achterste aansluitpunten te beperken (paneeldikte maximaal 40 mm)

Alleen een droge katoenen doek gebruiken voor het schoonmaken van het instrument.

### Vervanging van verbruiksmaterialen

Zekering: ter voorkoming van brand dient u de zekering met de gespecificeerde standaard te gebruiken (stroom spanning, type). Voor u de zekering vervangt moet u de netspanning uitschakelen en de stroomtoevoer onderbreken. Gebruik geen andere zekering en sluit de zekeringhouder niet kort.

## Instruções de segurança

	Para reduzir o risco de choque eléctrico que pode causar danos corporais, seguir todas as normas de segurança contidas nesta documentação.
	Terminal de protecção de terra. Fornecido para ligação do condutor do sistema da protecção de terra.

- Se este equipamento for usado de modo não especificado pelo fabricante, a protecção fornecida pelo equipamento pode não ser adequada.
- Não se deve substituir qualquer componente (ou peça) que não seja explicitamente especificado como substituível pelo nosso revendedor.
- Toda a cablagem deve estar de acordo com os códigos eléctricos locais e deve ser realizada por pessoal experiente devidamente autorizado.
- O terminal de terra deve ser ligado antes de ser feita qualquer outra cablagem (e desligado em último lugar).
- Recomenda-se um comutador na fonte de alimentação principal pr[ximo do equipamento.
- Se um fusível externo é utilizado para proteger o circuito eléctrico ao registador, o fusível tem de coincidir com o fusível do registador regulamentado (tipo de fusível) bem como com o "fuseholder" (porta de suporte).

### Especificações do Equipamento

Voltagem: 100 a 240 Vca/cc

Frequência: 50/60 Hz

Potência ou consumo de Corrente: 100 VA max.

### Condições Ambientais

Não operar o instrumento na presença de líquidos ou vapores inflamáveis. A operação de qualquer instrumento eléctrico em tal ambiente constitui um perigo para a segurança.

<b>Humidade</b>	Rolo	10 a 90 % RH não condensado
	Leque	15 a 80 % RH não condensado
<b>Temperatura</b>	Ambiente	Rolo: 0 a 50°C (32 a 122°F) Leque: 0 a 40°C (32 a 104°F)
	Armazenagem	-40 a 70°C (-40 a 158°F)
<b>Vibrações</b>	Frequência	10 a 60 Hz, amplitude de 0.14 mm
		60 a 150 Hz, 1 g de aceleração

### Instalação do Equipamento      Instruções

O Registador deve ser montado num painel para limitar o acesso do operador aos terminais traseiros (espessura máxima do painel 40 mm).

### de Limpeza

Usar apenas um cotonete seco para limpar a unidade.

### Substituição de Consumíveis

Fusível: Para evitar um incêndio certifique-se de que usa um fusível com especificações standard (voltagem, corrente, tipo). Antes de substituir o fusível, desligue a alimentação e desligue os fios da fonte de alimentação. Não usar fusíveis diferentes ou fazer curto circuito do suporte de fusível.

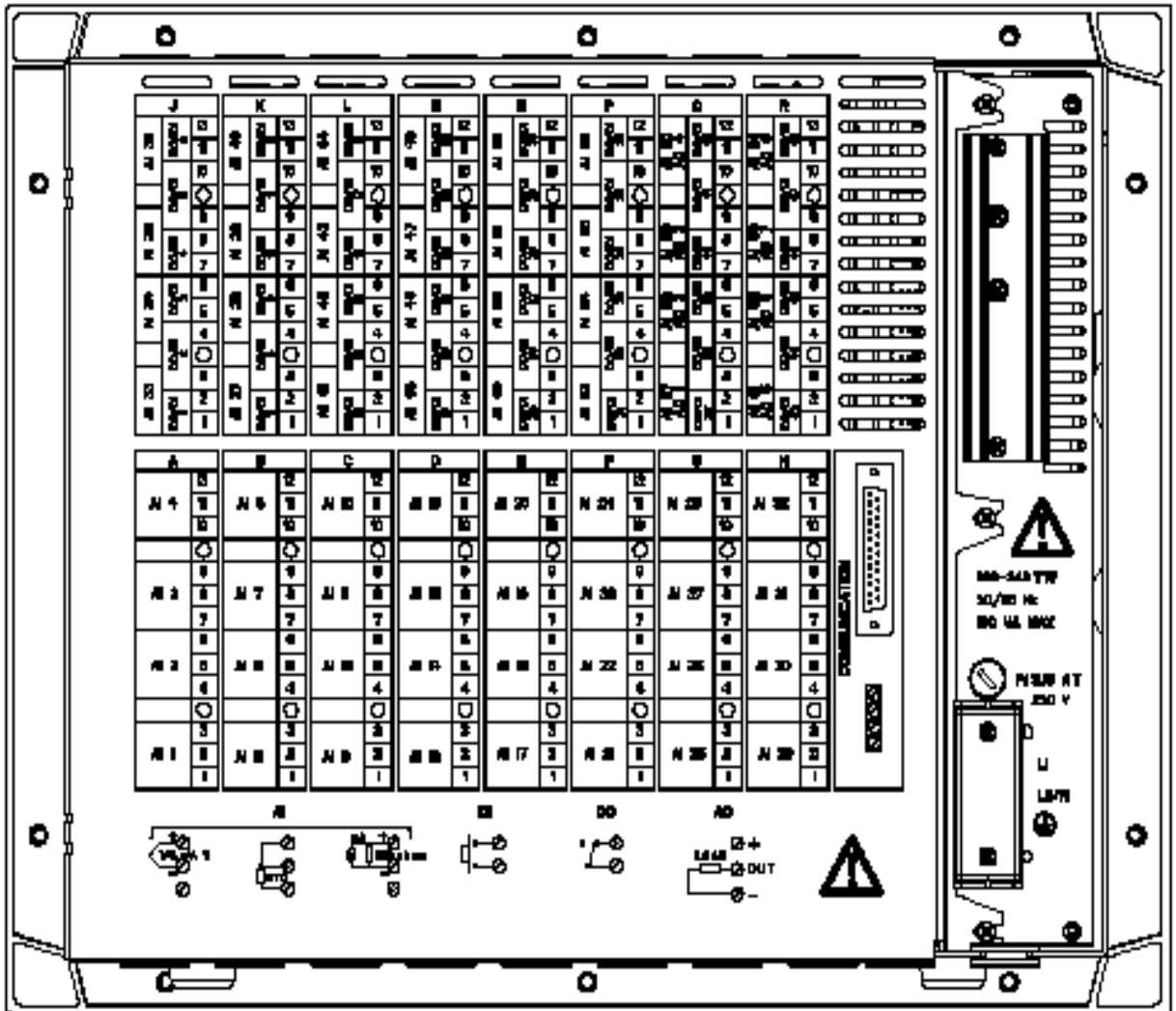

<b>→ DA</b>	Positioner		<b>(A) KOMMUNIKATION</b> <b>(B) BELASTNING</b> <b>(C) 100 VA MAX</b> <b>(D) F 3,15 A T</b>
<b>AI</b> = Analog indgange <b>AO</b> = Externe udgange <b>DI</b> = Digitale indgange <b>DO</b> = Digitale udgange (Relæ)	Fra <b>A</b> til <b>F</b> (laveste rack) Fra <b>N</b> til <b>P</b> (øverste rack) Fra <b>J</b> til <b>P</b> (øverste rack) Fra <b>J</b> til <b>P</b> (øverste rack)		
Bemærk: Alle terminalstik kan tages fra printkortene for at gøre installationen nemmere.			

<b>→ FI</b>	Liitännäpaikat		<b>(A) Väyläliityntä</b> <b>(B) Kuorma</b> <b>(C) 100 VA MAX</b> <b>(D) Sulake 3,15 A hidas</b>
<b>AI</b> = Analogiatulo <b>AO</b> = Apulähtö <b>DI</b> = Kosketintulo <b>DO</b> = Kosketinlähtö (Relé)	<b>A - F</b> (alemmat liittynät) <b>N - P</b> (ylemmät liittynät) <b>J - P</b> (ylemmät liittynät) <b>J - P</b> (ylemmät liittynät)		
HUOM: Liitäntärimat voidaan irrottaa kotelosta kytkentä- ja huoltotöiden helpottamiseksi.			

<b>→ SW</b>	Positioner		<b>(A) KOMMUNIKATION</b> <b>(B) LAST</b> <b>(C) 100 VA MAX</b> <b>(D) F 3,15 A T</b>
<b>AI</b> = Analog ingång <b>AO</b> = Extra utgång <b>DI</b> = Digital ingång <b>DO</b> = Digital utgång (Relä)	Från <b>A</b> till <b>F</b> (Undre rack) Från <b>N</b> till <b>P</b> (Övre rack) Från <b>J</b> till <b>P</b> (Övre rack) Från <b>J</b> till <b>P</b> (Övre rack)		
Obs.: Kopplingsplinten kan tagas bort ifrån kretskortet för att underlätta inkopplingen och eventuellt kortbyte.			

<b>→ IT</b>	Posizioni		<b>(A) COMUNICAZIONE</b> <b>(B) CARICO</b> <b>(C) 100 VA MAX</b> <b>(D) F 3,15 A T</b>
<b>AI</b> = Ingresso analogico <b>AO</b> = Uscita ausiliaria <b>DI</b> = Ingresso digitale <b>DO</b> = Uscita digitale (Relè)	Da <b>A</b> a <b>F</b> (parte inferiore) Da <b>N</b> a <b>P</b> (parte superiore) Da <b>J</b> a <b>P</b> (parte superiore) Da <b>J</b> a <b>P</b> (parte superiore)		
Nota: I blocchi terminali possono essere rimossi dalla scheda per un piu' facile cablaggio e per la sostituzione della scheda.			

<b>→ SP</b>	Posiciones		<b>(A) COMUNICACION</b> <b>(B) CARGA</b> <b>(C) 100 VA MAX</b> <b>(D) F 3,15 A T</b>
<b>AI</b> = (EA) Entrada Analógica <b>AO</b> = (SA) Salida Auxiliar <b>DI</b> = (ED) Entrada Digital <b>DO</b> = (SD) Salida Digital (Relé)	De <b>A</b> a <b>F</b> (Bastidor Inferior) De <b>N</b> a <b>P</b> (Bastidor Superior) De <b>J</b> a <b>P</b> (Bastidor Superior) De <b>J</b> a <b>P</b> (Bastidor Superior)		
Nota: Los bloques de terminales pueden desmontarse de la tarjeta, esto facilita el cableado y sustitución de la tarjeta.			

<b>→ GR</b>	ΤΟΠΟΘΕΤΗΣΕΙΣ		<b>(A)</b> ΕΠΙΚΟΙΝΩΝΙΑ <b>(B)</b> ΦΟΡΤΙΟ <b>(C)</b> 100 ζΑ ΜΕΓΙΣΤΗ ΚΑΤΑΝΑΛΩΣΗ <b>(D)</b> Φ 3,15 Α Τ
<b>AI</b> = ΑΝΑΛΟΓΙΚΗ ΕΙΣΟΔΟΣ <b>AO</b> = ΒΟΗΘΗΤΙΚΗ ΕΞΟΔΟΣ <b>DI</b> = ΥΠΦΙΑΚΗ ΕΙΣΟΔΟΣ <b>DO</b> = ΥΗΦΙΑΚΗ ΕΞΟΔΟΣ (Ρελε)	ΑΠΟ ΤΟ <b>A</b> ΣΤΟ <b>F</b> (ΚΑΤΩ ΡΑΚ ) ΑΠΟ ΤΟ <b>N</b> ΣΤΟ <b>P</b> (ΑΝΩ ΡΑΚ ) ΑΠΟ ΤΟ <b>J</b> ΣΤΟ <b>P</b> (ΑΝΩ ΡΑΚ ) ΑΠΟ ΤΟ <b>J</b> ΣΤΟ <b>P</b> (ΑΝΩ ΡΑΚ )		
ΣΗΜΕΙΩΣΗ: ΤΑ ΒΗΖΜΑΤΑ ΜΠΟΡΟΥΝ ΝΑ ΑΠΟΣΥΝΔΕΘΟΥΝ ΑΠΟ ΤΗΝ ΠΛΑΚΕΤΑ ΓΙΑ ΕΥΚΟΛΟΤΕΡΗ ΚΑΠΩΔΙΩΣΗ ΚΑΙ ΑΝΤΙΚΑΤΑΣΤΑΣΗ ΠΛΑΚΕΤΑΣ.			

<b>→ DU</b>	Posities		<b>(A)</b> COMMUNICATIE <b>(B)</b> BELASTING <b>(C)</b> 100 VA MAX <b>(D)</b> F 3,15 A T
<b>AI</b> = Analoge ingang <b>AO</b> = Extra uitgang <b>DI</b> = Digital ingang <b>DO</b> = Digital uitgang (Relais)	Van <b>A</b> naar <b>F</b> (onderste rek) Van <b>N</b> naar <b>P</b> (bovenste rek) Van <b>J</b> naar <b>P</b> (bovenste rek) Van <b>J</b> naar <b>P</b> (bovenste rek)		
Opmerking: De aansluitingsstrippen kunnen van de kaart worden verwijderd voor vereenvoudiging van het bedraden en vervanging van de kaart.			

<b>→ PO</b>	Posições		<b>(A)</b> Comunicação <b>(B)</b> Carregar <b>(C)</b> 100 VA MAX <b>(D)</b> F 3,15 A T
<b>AI</b> = Entrada Analógica <b>AO</b> = Sa da Auxiliar <b>DI</b> = Entrada Digital <b>DO</b> = Sa da Digital (Relé)	De <b>A</b> a <b>F</b> (Bastidor Inferior) De <b>N</b> a <b>P</b> (Bastidor Superior) De <b>J</b> a <b>P</b> (Bastidor Superior) De <b>J</b> a <b>P</b> (Bastidor Superior)		
Nota: Os blocos de terminais poderão ser retirados da carta electrónica para facilitar a cablagem e a substituição da carta electrónica.			







## Sales and Service

For application assistance, current specifications, pricing, or name of the nearest Authorized Distributor, contact one of the offices below.

### ASIA PACIFIC

#### Control Products

Asia Pacific Headquarters  
Phone: +(65) 6355-2828  
Fax: +(65) 6445-3033

#### Asia Pacific Global Technical Support

**Field Instruments**  
Phone: +65 6580 3156  
Fax: +65 6445-3033  
**Process Instruments**  
Phone: (603) 76950 4777  
Fax: (603) 7958 8922

#### Australia

Honeywell Limited  
Phone: +(61) 7-3846 1255  
FAX: +(61) 7-3840 6481  
Toll Free 1300-36-39-36  
Toll Free Fax:  
1300-36-04-70

#### China – PRC – Beijing

Honeywell China Inc.  
Phone: +(86-10) 8458-3280  
Fax: +(86-10) 8458-4650

#### China – PRC – Shanghai

Honeywell China Inc.  
Phone: (86-21) 5257-4568  
Fax: (86-21) 6237-2826

#### China – PRC – Chengdu

Honeywell China Inc.  
Phone: +(86-28) 8678-6348  
Fax: +(86-28) 8678-7061

#### China – PRC – Xi'an

Honeywell China Ltd - Xi'an.  
Phone: +(86-29) 8833-7490  
Fax: +(86-29) 8833-7489

#### China – PRC – Shenzhen

Honeywell China Inc.  
Phone: +(86) 755-2518-1226  
Fax: +(86) 755-2518-1221

#### Indonesia

PT Honeywell Indonesia  
Phone: +(62) 21-535-8833  
FAX: +(62) 21-5367 1008

#### India Automation India Ltd.

Honeywell Ltd.  
Phone: +(91) 5603-9400  
Fax: +(91) 5603-9600

#### Japan

Honeywell Inc.  
Phone: +(81) 3 6730 7150  
Fax: +(81) 3 6730 7228

#### Malaysia

Honeywell Engineering Sdn Bhd  
Phone: +(60-3) 7950-4776  
Fax: +(60-3) 7958-8922

#### New Zealand

Honeywell Limited  
Phone: +(64-9) 623-5052  
Fax: +(64-9) 623-5060  
Toll Free (0800) 202-088

#### Philippines

Honeywell Systems (Philippines) Inc.  
Phone: +(63-2) 633-2830-31/  
636 1661-62  
Fax: +(63-2) 638-4013

#### Singapore

Honeywell Pte Ltd.  
Phone: +(65) 6580 3278  
Fax: +(65) 6445-3033

#### South Korea

Honeywell Korea Co Ltd  
Phone: +(822) 799 6315  
Fax: +(822) 792 9015

#### Thailand

Honeywell Systems (Thailand) Ltd.  
Phone: +(662) 693-3099  
FAX: +(662) 693-3089

#### Taiwan R.O.C.

Honeywell Taiwan Ltd.  
Phone: +(886-2) 2245-1000  
FAX: +(886-2) 2245-3241

#### SE Asia Countries

see Honeywell Pte Ltd (Singapore)  
for: Pakistan, Cambodia, Guam, Laos, Myanmar, Vietnam, East Timor

#### SE Asia Countries

see Honeywell Automation India Ltd for: Bangladesh Nepal Sri Lanka

### EUROPE

#### Austria

Honeywell Austria GmbH  
Phone: +43 (316)400123  
FAX: +43 (316)40017

#### Belgium

Honeywell SA/NV  
Phone: +32 (0) 2 728 24 07  
FAX: +32 (0) 2 728 22 45

#### Bulgaria

Honeywell EOOD  
Phone: +(359) 2 40 20 900  
FAX: +(359) 2 40 20 990

#### Czech Republic

Honeywell spol. s.r.o.  
Phone: +420 242 442 232  
FAX: +420 242 442 131

#### Denmark

Honeywell A/S  
Phone: +(45) 39 55 55 55  
FAX: +(45) 39 55 55 58

#### Finland

Honeywell OY  
Phone: +358 (0)20752 2753  
FAX: +358 (0) 20752 2751

#### France

Honeywell SA  
Phone: +33 (0)1 60198075  
FAX: +33 (0)1 60198201

#### Germany

Honeywell AG  
Phone: +49 (69)8064-299  
FAX: +49 (69)806497336

#### Hungary

Honeywell Kft.  
Phone: +36-1-451 4300  
FAX: +36-1-451 4343

#### Italy

Honeywell S.p.A.  
Phone: +390292146307  
FAX: +39 0292146377

#### The Netherlands

Honeywell B.V.  
Phone: +31 (0) 20 5656200  
FAX: +31 (0) 20 5656210

#### Norway

Honeywell A/S  
Phone: (45) 39 55 55 55

#### Poland

Honeywell Sp. zo.o  
Phone: +48-22-6060900  
FAX: +48-22-6060901

#### Portugal

Honeywell Portugal Lda  
Phone: +351 21 424 5000  
FAX: +351 21 424 50 99

#### Romania

Honeywell Bucharest  
Phone: +40 (0) 21 2316437  
FAX: +40 (0) 21 2316439

#### Russian Federation (RF), ZAO "Honeywell"

Phone: +7 (095) 796 98 00  
FAX: +7 (495) 797 99 64

#### Slovak Republic

Honeywell s.r.o.  
Phone: +421-2-58247 410  
FAX: +421-2-58247 415

#### Spain

Honeywell S.A.  
Phone: +34 (0)91313 61 00  
FAX: +34 (0)91313 61 30

#### Sweden

Honeywell AB  
Phone: +(46) 8 775 55 00  
FAX: +(46) 8 775 56 00

#### Switzerland

Honeywell AG  
Phone: +41 18552448  
FAX: +(41) 1 855 24 45

#### Turkey

Honeywell Turkey A.S.  
Phone: +90 216 578 71 00  
FAX: +90 216 575 66 35

#### Ukraine

Honeywell  
Tel: +380-44-201 44 74  
Fax: +380-44-201-44-75

#### United Kingdom

Honeywell Control Systems Ltd.  
Phone: +44 (0)1344 655251  
FAX: +44 (0) 1344 655554

### MIDDLE EAST

#### Abu Dhabi U A E

Middle East Headquarters  
Honeywell Middle East Ltd.  
Phone: +971 2 4041246  
FAX: +971 2 4432536

#### Sultanate of Oman

Honeywell & Co Oman LLC  
Phone: +968 24 701153/  
Ext.33  
FAX +968 24 787351

#### Saudia Arabia

Honeywell Turki Arabia Ltd  
**Jubail Office**  
Phone: +966-3-341-0140  
Fax: +966-3-341-0216  
Honeywell - ATCO

#### Dammam Office

Phone: 0096638304584  
Fax: 0096638338059

#### Kuwait

Honeywell Kuwait KSC  
Phone: +965 242 1327 to 30  
Fax: +965 242 8315  
And  
Phone: +965 326  
2934/1821 Fax: +965 326  
1714

### AFRICA

#### Mediterranean & African Distributors

Honeywell SpA  
Phone: +39 (02) 250 10 604  
FAX: +39 (02) 250 10 659

#### South Africa (Republic of) and sub saharan

Honeywell Southern Africa  
Honeywell S.A. Pty. Ltd.  
Phone: +27 11 6958000  
FAX +27 118051504

### NORTH AMERICA

#### Canada

Honeywell LTD  
Phone: 1-800-737-3360  
FAX: 1-800-565-4130

#### USA

Honeywell Process Solutions,  
Phone: 1-800-423-9883  
Or 1-800-343-0228  
Email: [ask-ssc@honeywell.com](mailto:ask-ssc@honeywell.com)

### LATIN AMERICA

#### Argentina

Honeywell S.A.I.C.  
Phone: +(54-11) 4383-3637  
FAX: +(54-11) 4325-6470

#### Brazil

Honeywell do Brasil & Cia  
Phone: +(55-11) 7266-1900  
FAX: +(55-11) 7266-1905

#### Chile

Honeywell Chile, S.A.  
Phone: +(56-2) 233-0688  
FAX: +(56-2) 231-6679

#### Mexico

Honeywell S.A. de C.V.  
Phone: +(52) 55 5259-1966  
FAX: +(52) 55 5570-2985

#### Puerto Rico

Honeywell Inc.  
Phone: +(809) 792-7075  
FAX: +(809) 792-0053

#### Trinidad

Honeywell Inc.  
Phone: +(868) 624-3964  
FAX: +(868) 624-3969

#### Venezuela

Honeywell CA  
Phone: +(58-2) 238-0211  
FAX: +(58-2) 238-3391

# Honeywell

## Honeywell Process Solutions

1860 West Rose Garden Lane  
Phoenix, Arizona 85027

[www.honeywell.com/ps](http://www.honeywell.com/ps)

US11-6199 Iss.9

March 2010

©2010 Honeywell International Inc.