



Mark II Molded Plastic Manometers

3% Accuracy For Stationary And Portable Applications At Minimum Cost



Fig. 13-1, Mark II Model No. 25 inclined-vertical manometer. (shown with optional A-612 portable stand)



Fig. 13-2, Mark II Model No. 40-1 inclined manometer

Dwyer Mark II series molded manometers are of the inclined and inclined-vertical types. The curved inclined-vertical tube of the Model 25 gage provides higher ranges with more easily read increments at low readings. The Model 25 is excellent for general purpose work. The Model 40 inclined gage provides linear calibration and excellent resolution throughout its range. The Model 40 is ideally suited for air velocity and air filter gage applications. Both gage types are capable of pressure measurements above and below atmospheric as well as differential pressure measurements.

Construction — Mark II manometers are economically priced, compact and available in both stationary and portable configurations. Portable stand is standard on Model 40, available as optional A-612 stand for Model 25. Construction is simple with virtually indestructible molded white styrene-acrylonitrile housing, indicating tube and fluid wells, molded ABS knobs and zero adjust plunger, shock mounted glass level vial and leak proof “O” ring seals. Moderate overpressures are accommodated by an overflow tank incorporated in the Model 25. Greater protection is provided by float operated overflow traps in the Model 40. Scales are lithograph printed on aluminum and epoxy coated.

Installation — Mark II manometers can be mounted on any vertical surface with the two mounting screws provided. A built-in spirit level simplifies leveling before mounting screws are tightened. Simply fill the reservoir, adjust fluid level to zero, connect the tubing, and the gage is ready for operation.

Accessories — Included with each Mark II manometer are two tubing connectors for 1/8" pipe or sheet metal ducts, two mounting screws, 1/2 ounce bottle of indicating fluid, red and green pointer flags and complete instructions.

The Model 25 also includes 8 feet of flexible double column plastic tubing. Portable operation of the Model 25 is made possible by the use of the optional A-612 portable stand. A short piece of tubing can be slipped over the Model 25 pressure connections to contain the gage oil in transit.

The Model 40 contains two 4 1/2 foot lengths of clear plastic tubing, a plastic swing-out stand and leveling screw for portable operation. It also features convenient rapid shutoff pressure connections and integral overpressure safety traps.

OEM Specials — All Dwyer Mark II molded plastic manometers can be supplied in OEM quantities with your name or special graphics and scales.

STOCKED MODELS in bold

Model	Range	Fluid Used
Mark II 25	0-3 in w.c.	Red oil, .826 s.g.
Mark II 26	0-7 in. w.c.	Blue oil, 1.91 s.g.
Mark II 27*	0-7000 fpm	Red oil, .826 s.g.
Mark II 28*	0-10,500 fpm	Blue oil, 1.91 s.g.
Mark II MM-80	0-80 mm w.c.	Red oil, .826 s.g.
Mark II MM-180	0-180 mm w.c.	Blue oil, 1.91 s.g.
Mark II M-700Pa	10-0-700 Pa	Red oil, .826 s.g.

*Require Pitot tube at additional cost. See Air Velocity section

A-612 Portable Stand

Specifications

Accuracy: ±3% full scale

Maximum internal working pressure: 10 psi (70 kPa)

Maximum working temperature: 140°F. (60°C)

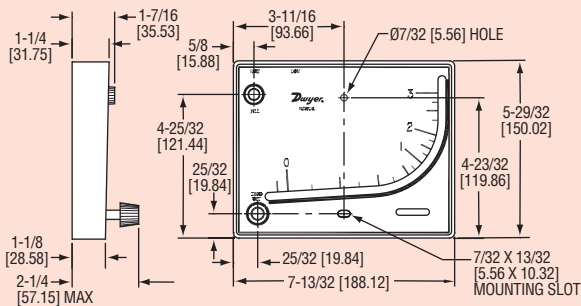

STOCKED MODELS in bold

Model	Range	Fluid Used
Mark II 40-1	.1-0-1.0 in. w.c.	Red oil, .826 s.g.
Mark II 40-25 mm	0-26 mm w.c.	Red oil, .826 s.g.
Mark II 40-250 Pa	10-0-250 Pa	Red oil, .826 s.g.
Mark II 41-2	.2-0-2.4 in. w.c.	Blue oil, 1.91 s.g.
Mark II 41-60 mm	0-60 mm w.c.	Blue oil, 1.91 s.g.
Mark II 41-600 Pa	20-0-600 Pa	Blue oil, 1.91 s.g.
Mark II 40-1-AV*	0-1.1 in. w.c. & 0-4200 fpm	Red oil, .826 s.g.
Mark II 40-250 Pa-AV*	0-260 Pa & 0-21 mps	Red oil, .826 s.g.
Mark II 41 -2-AV*	0-2.5 in. w.c. & 0-6300 fpm	Blue oil, 1.91 s.g.

*Require Pitot tube at additional cost. See Air Velocity section

A-606 Air Filter Kit

Specifications

Accuracy: ±3% full scale

Maximum internal working pressure: 15 psi (100 kPa)

Maximum working temperature: 130°F. (54°C)

Scale length: Approx. 8 3/4". (21 centimeters)

