

FLUSH DIAPHRAGM

ANC4B 316 stainless steel or black anodised aluminium switchcase to IP66 standards.

Calibrated adjustment scale.

Settings from 0.1 to 32 Bar.

Single or dual microswitch option.

Wetted parts NACE MR-01-75 compliant.

ATEX/IECEX Flameproof version
CE Ⓢ II2G Exd IIB + H₂T6...T2 Gb
Tamb -60°C to +40°C...90°C

ATEX/IECEX Intrinsically safe version
CE Ⓢ II1G Exia IIC T6...T2 Ga
Tamb -50°C to 78°C...+128°C

(For resistor certification refer to page 45)

PF261 TITAN ATEX/IECEX Exd, Exia CERTIFIED & INDUSTRIAL PRESSURE SWITCH



This range incorporates a flush diaphragm and is suitable for settings up to 32 Bar. It has been designed for use on processes involving mediums of a high viscosity level or containing suspended solids which would otherwise clog conventional recessed diaphragm models. Resistors can be incorporated for 'end of line' and short circuit monitoring. For specification and introduction to the Titan switch range refer to pages 44 and 45.

ADJUSTMENT RANGE (BAR G)	ADJUSTMENT RANGE (PSI)	MAX WORKING PRESSURE (BAR G)	DEADBAND FIXED (BAR G)	SPRING CODE	DIAPHRAGM CODE
0.1 - 3.1	2 - 44	12	< 0.35	B	32
1 - 7	15 - 105	12	< 0.7	W	32
2 - 16	30 - 230	40	< 1.6	B	15
4 - 32	60 - 460	40	< 3.2	W	15

PART NUMBER BREAKDOWN

B = ATEX Exd CERTIFIED O = ATEX Exia CERTIFIED A = INDUSTRIAL	DIAPHRAGM MATERIAL 2 = VITON (STANDARD) 1 = NITRILE	X = COVER PLATE (STANDARD)	ELECTRICAL ENTRY A = M20 STRAIGHT B = M20 ANGLED C = 1/2" NPT STR. F = M25 STRAIGHT
A = ALUMINIUM CASE S = ST. STEEL CASE	SPRING CODE (SEE RANGE SHEET)		
1 = STANDARD	PF 261 S 1 B / 2 B F 15 / 15 F S 2 X A		
1 = 1 x SPDT SWITCH 2 = 2 x SPDT SWITCH DUAL SWITCHES ARE MECHANICALLY LINKED TO PROVIDE DPDT SWITCHING ACTION	DIAPHRAGM CODE		BS EN 1092-1 FLANGE (REPLACES BS4504) FS2 = PN40 FLANGE 2" FS0 = SPECIAL - SEE TEXT OTHER SIZES AVAILABLE

NOTE: RESISTORS ARE INDICATED BY THE PREFIX "PR" IN PLACE OF "PF".

SPECIFICATION

Wetted parts : 316 St. steel

Process connections : 2" BS EN 1092-1 PN40 Flange. Other sizes available.

Diaphragm : Nitrile or Viton

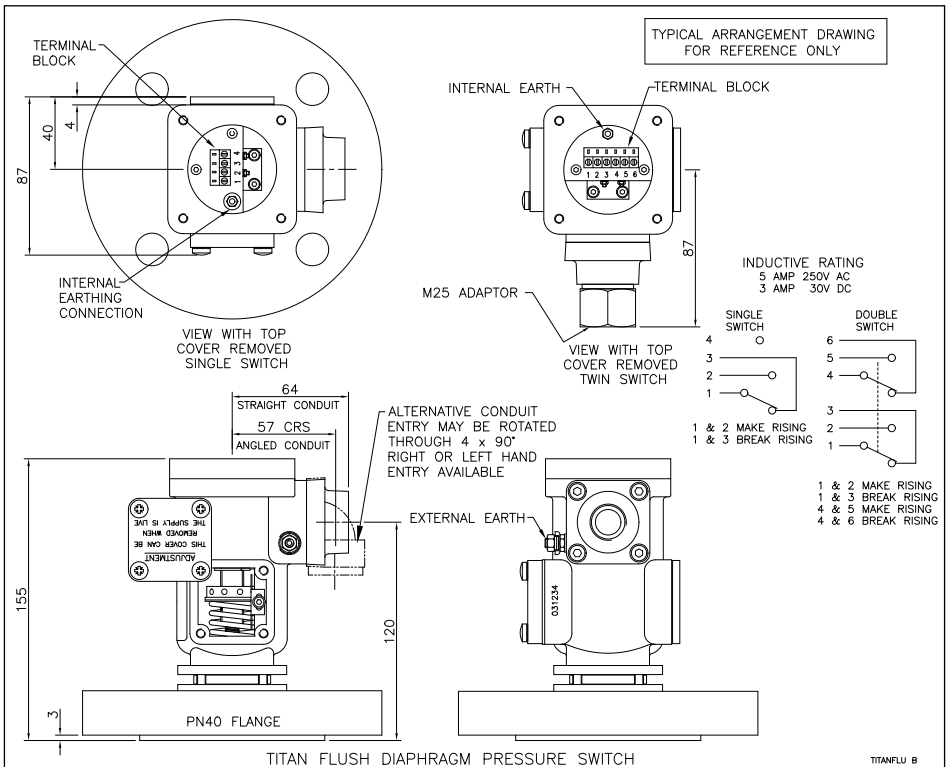

TITAN (XPB) ATEX/IECEX Exd, Exia INDUSTRIAL SWITCHES

INTRODUCTION

The Titan **pressure, differential pressure, temperature, level and flow** switches are designed for use in environments where explosive gases can be present (e.g. Gas fields, Oil rigs and Chemical plants etc.) and are dual ATEX/IECEX certified for CAT 1 Exia IIC T6...T2 and CAT 2 Exd IIB +H₂ T6...T2.

These switches are manufactured from a high quality casting which offers robust construction and protection to IP66 for use within heavily polluted industrial and marine environments. A special feature of the instruments is the separation of the flameproof and adjustment compartments allowing for safe on-site adjustment of the set point with power on and the switch in operation.

The TITAN Exd certified switches must be installed in accordance with BS EN 60017-14. The certification allows for mounting against a wall or bulkhead with the minimum flamepath distances specified not being applicable.

CALIBRATION

The design features a simple form of calibration adjustment against a scale plate. This allows users to either order units with a specific setting, or stock a mid range setting and then adjust to suit the application. This can be set safely with the switch supply live. On removal of the adjustment cover the adjusting ring can be turned with a small Tommy bar or Allen key. The setting is read from the centre of the red pointer ring against the calibrated scale plate. Rotation to the left will increase the set point and to the right decrease the set point. The adjustment mechanism incorporates a friction device to ensure set point will not change under vibration conditions.

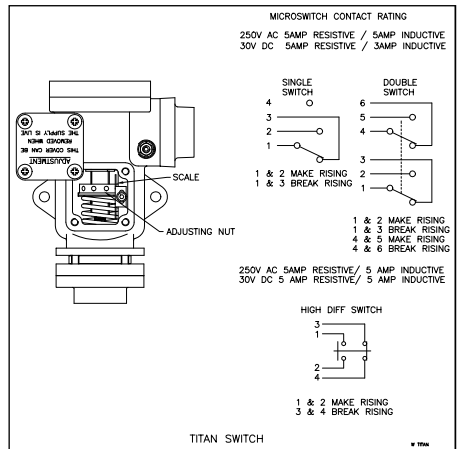

When we are requested to supply switches set at a specific point we can guarantee setting accuracy of less than 2%.



TITAN Exd



TITAN Exia (IS)



TITAN Exia (IS)
WITH RESISTORS

TECHNICAL SPECIFICATION

Switchcase and covers : ANC4B 316 stainless steel or black anodised aluminium.

Microswitch : 1 x SPCO/SPDT or 2 x SPCO/SPDT gold plated silver contacts. Dual switches are mechanically linked to provide DPDT switching action, reset of switches could be up to 3% apart. Dual microswitches may increase deadband by a factor of two.

Microswitch rating

5 Amps @ 250 VAC resistive and inductive.

5 Amps @ 30VDC resistive, 3 Amps @ 30 VDC inductive.

Electrical connections : Terminals suitable for cable 0.5 - 2.5 mm².
(Max 1.5mm² for dual microswitch version)

Electrical Conduit Entry : M20 x 1.5 straight or angled entry. ½” NPT via adaptors

Environmental Protection : Switches have been tested and certified by an external test house to IP66 in accordance with BS EN 60529 : 1992.

Vibration and shock parameters : Switches were subjected to Ministry of Defence Type Approval System Test Vibration DGS 350 Paras 0602 & 0603. Shock – BR3021.

Temperature Limitations : Pressure, Vacuum and Differential Pressure

Ambient : -50 to +85°C (standard) -60°C to 125°C (special).

Process : Diaphragm actuated* -50 to +90°C (Nitrile) or -20 to +150°C (Viton).
Piston actuated -40 to 120°C (Nitrile) or -20 to +150°C (Viton).

Storage* : -60 to +85°C.

* Unless otherwise stated

(for temperature, level and flow switches please refer to specific pages).

Certification : Dual ATEX/IECEx certified for gas hazardous areas.

Exd Flameproof (with or without resistors)

CE Ex II2G Exd IIB + H₂ T6...T2 Gb Tamb -60°C to +40...+90°C

Special conditions for safe use. 1) No modifications must be made to the flamepaths of the unit without consultation of the drawings listed on the certificate. 2) If temperature of the cable entry could exceed 70°C, suitably rated cable must be selected based on the Tmax shown above.

Exia Intrinsically Safe (without resistors)

CE Ex II1G Exia IIC T6...T2 Ga Tamb -50°C to +78°C...+128°C

Exia Intrinsically Safe (with resistors)

CE Ex II1G Exia IIC T5...T2 Ga Tamb -50°C to +72°C...+122°C

Special conditions for safe use. (Category 1, Zone 0) Aluminium may only be used when the ignition hazardous assessment shows that there is not risk of ignition from incendive, impact or abrasion sparks.

Accuracy : +/-1% at 20°C