

ENTRY THREAD SIZE
1/4" BSP.P
1/4" NPT
1/2" BSP.P
1/2" NPT

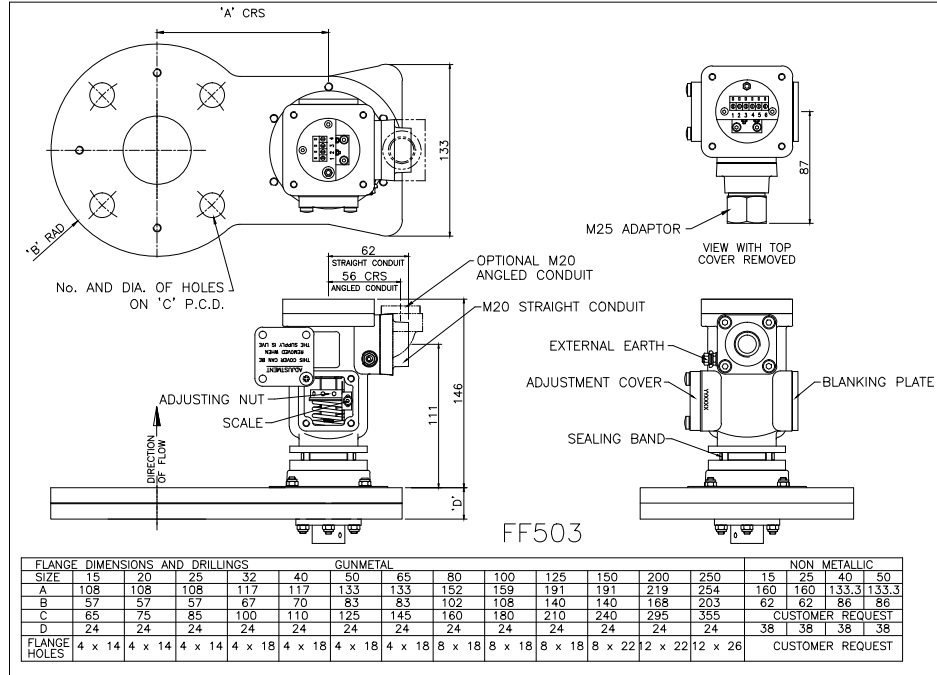

FLANGE DIMENSIONS AND DRILLINGS	GUNMETAL										NON METALLIC																								
	15	20	25	32	40	50	65	80	100	125	150	200	250	15	25	40	50																		
A	108	108	108	117	117	133	133	152	159	191	191	219	254	160	160	133.3	133.3																		
B	57	57	57	67	70	83	83	102	108	140	140	168	203	62	62	56	56																		
C	65	75	85	100	110	125	145	160	180	210	240	295	355	CUSTOMER REQUEST																					
D	24	24	24	24	24	24	24	24	24	24	24	24	24	38	38	38	38																		
FLANGE HOLES	4 x 14										4 x 14					4 x 18					4 x 18					4 x 18					CUSTOMER REQUEST				

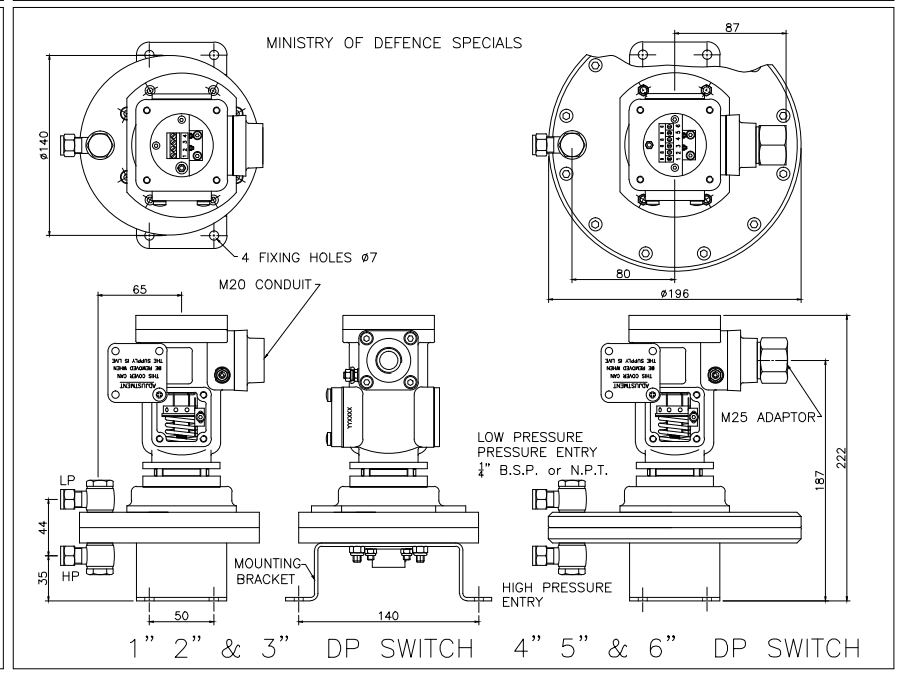
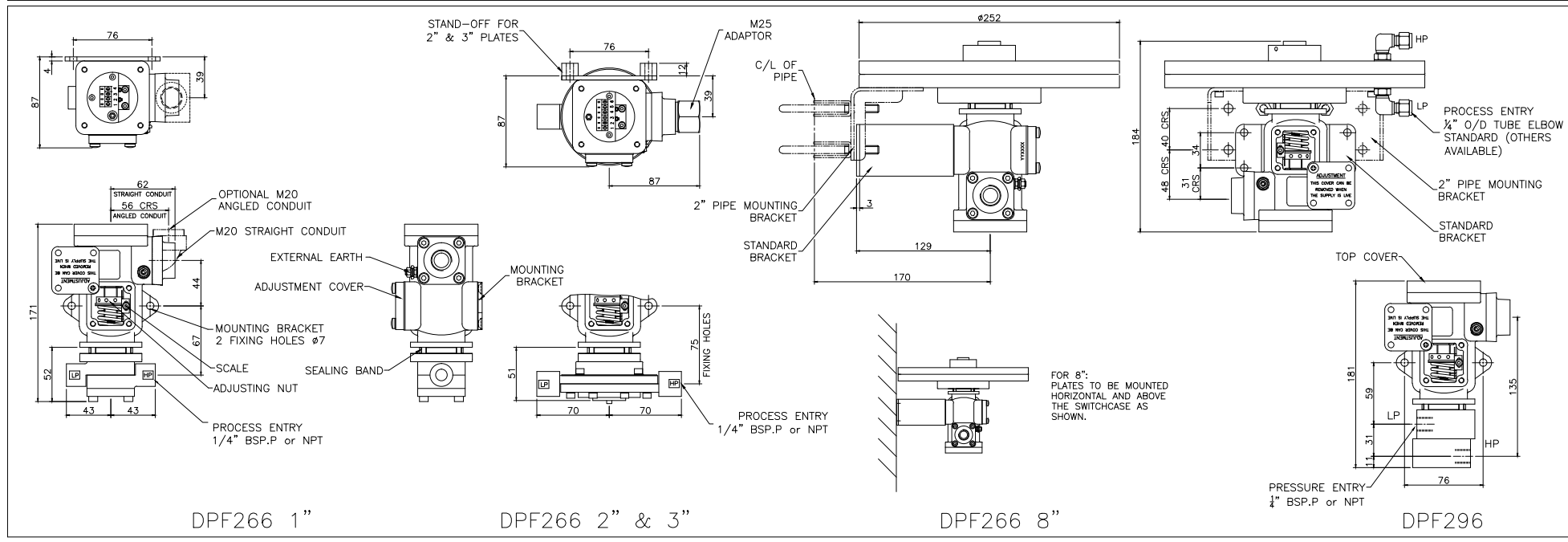
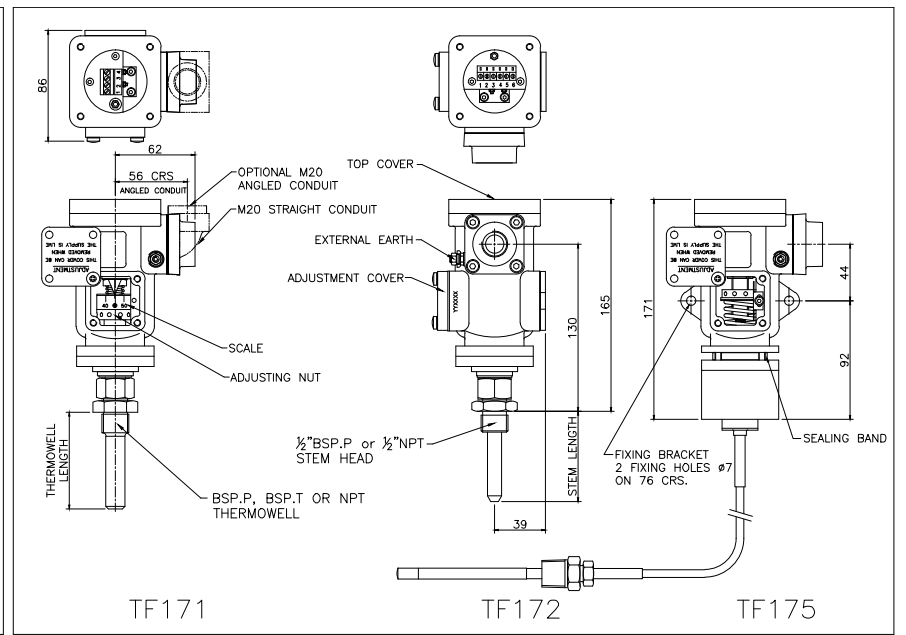