

USER'S GUIDE

Vaisala Humidity Calibrator HMK15



PUBLISHED BY

Vaisala Oyj
P.O. Box 26
FIN-00421 Helsinki
Finland

Phone (int.):+358 9 8949 1
Fax: +358 9 8949 2227

Visit our Internet pages at <http://www.vaisala.com/>

© Vaisala 2006

No part of this manual may be reproduced in any form or by any means, electronic or mechanical (including photocopying), nor may its contents be communicated to a third party without prior written permission of the copyright holder.

The contents are subject to change without prior notice.

Please observe that this manual does not create any legally binding obligations for Vaisala towards the customer or end user. All legally binding commitments and agreements are included exclusively in the applicable supply contract or Conditions of Sale.

Table of Contents

CHAPTER 1

GENERAL INFORMATION	3
About This Manual	3
General Safety Considerations.....	3
Feedback.....	4
Product Related Safety Precautions	4
Recycling	5
Warranty	6

CHAPTER 2

PRODUCT OVERVIEW	7
Introduction to Vaisala Humidity Calibrator	
HMK15	7
General.....	7
Salt Package Calibration Certificates	9

CHAPTER 3

PREPARING THE SALT SOLUTIONS	11
General Instructions	11
Preparing the Solutions	12

CHAPTER 4

INSTRUCTIONS FOR THE CALIBRATION OF HUMIDITY	
INSTRUMENTS	19
General Instructions	19
Thermometer.....	21
Calibration	23
Greenspan's Calibration Table¹	25
On-Site Calibrations and Transportation	26

CHAPTER 5
MAINTENANCE 31

CHAPTER 6
SPARE PARTS AND ACCESSORIES..... 33

CHAPTER 7
TECHNICAL DATA 35

CHAPTER 1

GENERAL INFORMATION

This chapter provides general notes for the manual and the product.

About This Manual

This manual provides information for operating, and maintaining Vaisala Humidity Calibrator HMK15.

General Safety Considerations

Throughout the manual, important safety considerations are highlighted as follows:

WARNING	Warning alerts you to a serious hazard. If you do not read and follow instructions very carefully at this point, there is a risk of injury or even death.
----------------	---

CAUTION	Caution warns you of a potential hazard. If you do not read and follow instructions carefully at this point, the product could be damaged or important data could be lost.
----------------	--

NOTE	Note highlights important information on using the product.
-------------	---

Feedback

Vaisala Customer Documentation Team welcomes your comments and suggestions on the quality and usefulness of this publication. If you find errors or have other suggestions for improvement, please indicate the chapter, section, and page number. You can send comments to us by e-mail: manuals@vaisala.com

Product Related Safety Precautions

Note the following precautions:

CAUTION	Do not modify the unit. Improper modification can damage the product or lead to malfunction.
----------------	--

CAUTION	Remember to check from the user's guide of your device if the adapter fitting is needed. If sensor accidentally soaks in salt liquid, remove it quickly and rinse with clean water. Let it dry before taking into use again.
----------------	--

NOTE	Never add water to dry LiCl salt; the salt may heat up so rapidly that it splashes out of the chamber.
-------------	--

NOTE	LiCl is harmful when swallowed; the solution is also corrosive.
-------------	---

Recycling



Recycle all applicable material.



Dispose of batteries and the unit according to statutory regulations. Do not dispose of with regular household refuse.

Warranty

Vaisala hereby represents and warrants all Products manufactured by Vaisala and sold hereunder to be free from defects in workmanship or material during a period of twelve (12) months from the date of delivery save for products for which a special warranty is given. If any Product proves however to be defective in workmanship or material within the period herein provided Vaisala undertakes to the exclusion of any other remedy to repair or at its own option replace the defective Product or part thereof free of charge and otherwise on the same conditions as for the original Product or part without extension to original warranty time. Defective parts replaced in accordance with this clause shall be placed at the disposal of Vaisala.

Vaisala also warrants the quality of all repair and service works performed by its employees to products sold by it. In case the repair or service works should appear inadequate or faulty and should this cause malfunction or nonfunction of the product to which the service was performed Vaisala shall at its free option either repair or have repaired or replace the product in question. The working hours used by employees of Vaisala for such repair or replacement shall be free of charge to the client. This service warranty shall be valid for a period of six (6) months from the date the service measures were completed.

This warranty is however subject to following conditions:

- a) A substantiated written claim as to any alleged defects shall have been received by Vaisala within thirty (30) days after the defect or fault became known or occurred, and
- b) The allegedly defective Product or part shall, should Vaisala so require, be sent to the works of Vaisala or to such other place as Vaisala may indicate in writing, freight and insurance prepaid and properly packed and labelled, unless Vaisala agrees to inspect and repair the Product or replace it on site.

This warranty does not however apply when the defect has been caused through

- a) normal wear and tear or accident;
- b) misuse or other unsuitable or unauthorized use of the Product or negligence or error in storing, maintaining or in handling the Product or any equipment thereof;
- c) wrong installation or assembly or failure to service the Product or otherwise follow Vaisala's service instructions including any repairs or installation or assembly or service made by unauthorized personnel not approved by Vaisala or replacements with parts not manufactured or supplied by Vaisala;
- d) modifications or changes of the Product as well as any adding to it without Vaisala's prior authorization;
- e) other factors depending on the Customer or a third party.

Notwithstanding the aforesaid Vaisala's liability under this clause shall not apply to any defects arising out of materials, designs or instructions provided by the Customer.

This warranty is expressly in lieu of and excludes all other conditions, warranties and liabilities, express or implied, whether under law, statute or otherwise, including without limitation any implied warranties of merchantability or fitness for a particular purpose and all other obligations and liabilities of Vaisala or its representatives with respect to any defect or deficiency applicable to or resulting directly or indirectly from the Products supplied hereunder, which obligations and liabilities are hereby expressly cancelled and waived. Vaisala's liability shall under no circumstances exceed the invoice price of any Product for which a warranty claim is made, nor shall Vaisala in any circumstances be liable for lost profits or other consequential loss whether direct or indirect or for special damages.

CHAPTER 2

PRODUCT OVERVIEW

Introduction to Vaisala Humidity Calibrator HMK15

General

The HMK15 humidity calibrator has been developed for calibration and checking of humidity probes and transmitters. The functioning of the calibrator is based on the fact that certain salt solutions generate a certain relative humidity in the air above them.

The four holes in the chamber cover are designed for Vaisala probes and transmitters with 12 mm, 13.5 mm (2 holes) and 18.5 mm diameters.

The salt solutions suitable for the HMK15 calibrator are for example lithium chloride LiCl (11 %RH), magnesium chloride MgCl₂ (33 %RH), sodium chloride NaCl (75 %RH) and potassium sulphate K₂SO₄ (97 %RH).

In calibration, the sensor head is inserted into a salt chamber containing a saturated salt solution. The probe/transmitter reading is then adjusted to the correct value, that is to the humidity that the specific salt solution generates at that particular temperature.

Calibration is usually performed at least at two different humidities to ensure the sensor accuracy over the entire humidity range (0 ... 100 %RH).

The HMK15 calibrator is suitable for both laboratory and field usage. During transportation, the chambers can be tightly closed with specially designed transit covers. The optional transit bag (order code HM27032) helps to transport the calibrator in the vertical position. Furthermore, the bag can be used for housing the calibrator also during calibration.

The following photo shows the HMK15 calibrator with some accessories (marked with *):

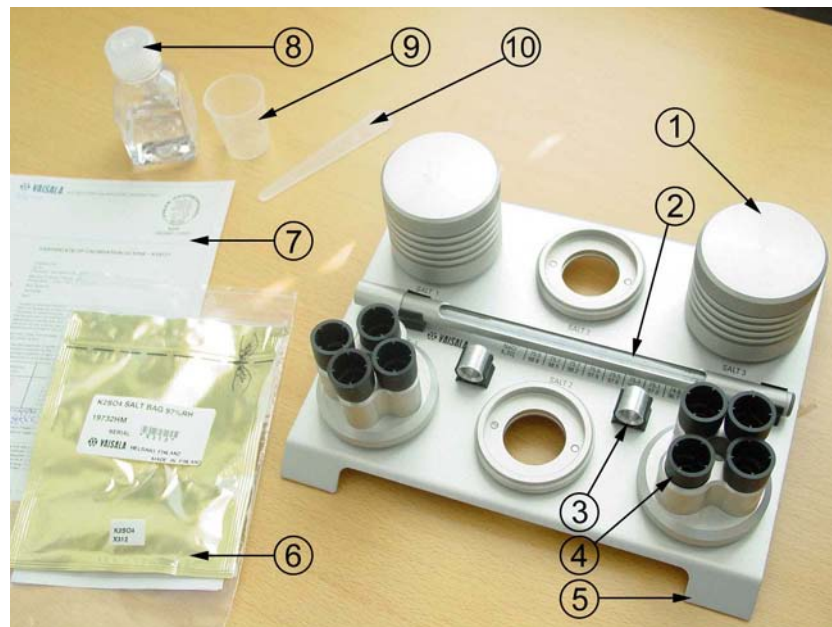

0606-164

Figure 1 The HMK15 calibrator with some accessories (*)

The following numbers refer to Figure 1 above:

- 1 = Salt chamber
- 2 = Thermometer
- 3 = Adapter fitting
- 4 = Plugs
- 5 = Base plate

- 6 = * Ready-dosed salt package with calibration certificate
- 7 = Calibration certificate for thermometer
- 8 = * Ion-exchanged water
- 9 = Measurement cup
- 10 = Measurement spoon

Accessories include additional salt chambers, ion exchanged water, transit bag and ready-dosed salt packages (LiCl 11 %RH, MgCl₂ 33 %RH, NaCl 75 %RH, K₂SO₄ 97 %RH).

Salt Package Calibration Certificates

Vaisala's ready-dosed salt packages are delivered with calibration certificates given on the basis of a batch check. In other words, a sample of packages are taken from a batch and salts are prepared according to the instructions given in this manual. These salt solutions are then checked at Vaisala Oy's Measurement Standards Laboratory (this calibration laboratory is accredited by FINAS, a member of the European Cooperation for Accreditation of Laboratories). The calibration certificate certifies that the equilibrium humidities generated by these salt solutions correspond to Greenspan's calibration table within the specified accuracy (see Chapter 7 Technical Data on page 35).

This page intentionally left blank.

CHAPTER 3

PREPARING THE SALT SOLUTIONS

General Instructions

- Prepare the salts using the equipment provided with the calibrator or make sure that all accessories used are suitable for preparing salt solutions and are absolutely clean. If necessary, wash them carefully and rinse several times before preparing the salt solutions. The last rinse must be made with distilled or ion exchanged water.
- The salts are quick and easy to prepare with Vaisala's ready-dosed salt packages. If you do not use ready-dosed salt packages, measure the salts using the measurement cup provided. Make sure that the cup is clean before measuring the salts. In the following instructions, the required amounts are given in grammes and millilitres. The salt solutions must be prepared from salts of pro analysis grade; these are available in agencies selling industrial chemicals. Note that the water must be distilled or ion exchanged (conductivity $< 0.25 \mu\text{S/cm}$). Ion exchanged water can also be ordered as an accessory for the HMK15 calibrator (order code 19767HM).
- Handle the salts and equipment carefully and keep them absolutely clean so that the salts are not contaminated. Make sure that the salts do not mix.

- At the bottom of the salt chamber there must not be more than 1 cm of undissolved salt and liquid. Otherwise, the sensor to be calibrated can be immersed into the solution. If necessary, verify the amount for example with the measurement spoon.
- Various standards (ASTM E104-85, DIN 50008, JIS Z8806) include recommendations and instructions on how to prepare and store salt solutions.

Preparing the Solutions

Lithium chloride generates a reference humidity of approximately 11 %RH. It is normally used as the dry end (offset) reference.

NOTE

Never add water to dry LiCl salt; the salt may heat up so rapidly that it splashes out of the chamber.

NOTE

LiCl is harmful when swallowed; the solution is also corrosive.

NOTE

If the LiCl solution is used or stored in temperatures below +18°C, its equilibrium humidity changes permanently.

Magnesium chloride generates a reference humidity of approximately 33 %RH. It is often used as a check point if calibration is performed at more than two points.

Sodium chloride generates a reference humidity of approximately 75 %RH. It is used as the wet end reference (gain) for probes measuring in applications with normal humidities.

Potassium sulphate generates a reference humidity of approximately 97 %RH. Potassium sulphate is used as the wet end reference (gain) for probes measuring in applications with very high humidities (90 ... 100 %RH, for example outdoor and concrete measurements).

Prepare the salt solutions according to the following instructions. Measure the salts carefully if you do not use the ready-dosed packages.

1. Take the calibrator out of the box. Open the transit cover of the chamber. Remove the measurement cover from the chamber holder and press the transit cover on the holder (see Figure 2).



0606-165

Figure 2 Press the transit cover on a chamber holder

2. Pour ion exchanged water into the chamber; the required amounts are given in the table:

LiCl	12 ml of water
MgCl ₂	3 ml of water
NaCl	10 ml of water
K ₂ SO ₄	10 ml of water



0606-166

Figure 3 Pour a correct dose of ion exchanged water into the chamber; dry the measurement cup

3. Sprinkle the contents of a salt package (or measure the salt according to the table) in small quantities into the chamber, stirring constantly. When measuring with the measurement cup, make sure that the cup is clean and dry. Rinse and dry the cup after every use.

LiCl	15 g or 18 ml
MgCl ₂	30 g or 30 ml
NaCl	20 g or 15 ml
K ₂ SO ₄	30 g or 20 ml



0606-167

Figure 4 Sprinkle a correct dose of salt into the chamber stirring constantly

4. When all salt has been sprinkled into the chamber, the saturated salt solution should have the ratio of 60 ... 90 % undissolved salt to 10 ... 40 % liquid.
5. Close the chamber with the chamber cover (Figure 5).



0606-168

Figure 5 Close the chamber with the chamber cover

6. Fasten the salt chamber on the holder in the base plate and close the measurement holes with rubber plugs. The chambers can also be used as individual checkers without the base plate.

NOTE

The plugs have three steps, each of which is suitable for a certain hole diameter: the first step for the 12 mm, the second step for the 13.5 mm and the third step for the 18.5 mm hole. Keep the holes always closed when not calibrating.

7. Write the preparation date on a sticker and mark the chamber with it. If you use a ready-dosed salt package, use the sticker with the batch code. Mark all parts of the salt chamber (chamber, chamber cover and transit cover) with stickers. This way, various covers and different salts do not get mixed.



0606-169

Figure 6 Mark the chamber and covers with stickers

8. Allow approximately 24 hours for stabilization before use so that the salt solution reaches the equilibrium humidity.
9. See Chapter 5 Maintenance on page 31 on how to maintain the salt solutions.

NOTE

If you do not use the instrument for a longer period of time, close the chambers with transit covers.

This page intentionally left blank.

CHAPTER 4

INSTRUCTIONS FOR THE CALIBRATION OF HUMIDITY INSTRUMENTS

General Instructions

Usually, the errors during humidity calibration are due to temperature differences. A temperature difference of ± 1 °C at +20 °C between the air in the chamber and the sensor causes an error of ± 3 %RH at 50 %RH and an error of ± 6 %RH at 97 %RH. The more the transportation or process temperatures differ from the temperature at the calibration site, the longer the stabilization time required. In laboratory use, the calibrator should be stored in that part of the room where the temperature is most stable. The calibrator must be kept out of direct sunlight and away from localized heat sources, such as spot lights, heaters and soldering irons. If the probe/transmitter is checked against several humidity references, the checking must first be made at the dry end. More detailed instructions are given in individual manuals of transmitters and probes.

Handle the probe as little as possible. Do not hold the salt chamber or other parts of the calibrator in hand during calibration as they warm up and cause errors in the readings.

NOTE Even the smallest water drop on the probe near the sensors distorts the readings. Make sure that chamber covers and plugs are carefully closed.

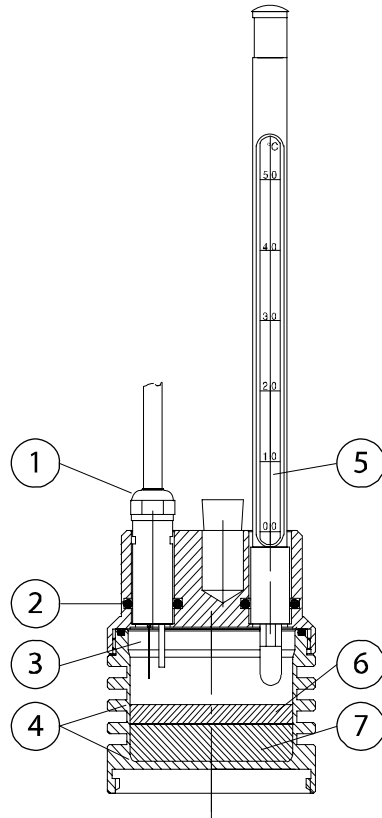

0606-170

Figure 7 Salt chamber

The following numbers refer to Figure 7 above

- 1 = HMP233 probe
- 2 = O-rings
- 3 = Sensors
- 4 = Max. 1 cm
- 5 = Thermometer
- 6 = Saturated salt solution
- 7 = Undissolved salt

Thermometer

The calibrator includes a thermometer which can contain either mercury or red capillary liquid. If the thermometer contains mercury, it is delivered with a calibration certificate. The accuracy of the mercury thermometer is sufficient for checking the transmitter's temperature channel if desired. The mercury thermometer has been calibrated at five points and the result is traceable to the Measurement Standards Laboratory of the Centre for Metrology and Accreditation in Finland. For more accurate results, use the corrections given in the calibration certificate or their interpolated values. Consider also the parallax error which may occur while reading the results. The mercury thermometer should be recalibrated within three years in order to maintain the traceability.

The manufacturer of the thermometer with red capillary liquid provides it with a factory calibration certificate. As the accuracy and stability of this kind of a thermometer are inferior to those of a mercury thermometer, it is not recommended to be used for checking the temperature channel of the transmitter.

The sleeve at the end of the thermometer's protective tube can be used in two different positions. The thermometer is delivered with the sleeve in such a position that it protects the part containing the capillary liquid. When turned the other way round, it acts as an adapter when the thermometer is inserted into the 13.5 mm hole (see Figure 8).

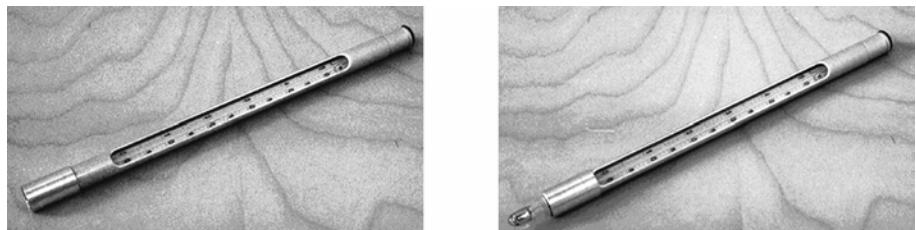

0606-171

Figure 8 The sleeve protects the part with capillary liquid (on the left) or acts as an adapter (on the right)

During calibration, the thermometer is inserted into the 13.5 mm hole of a salt chamber. Press it downwards until it passes the O-rings. The thermometer is correctly in place when you can feel a resistance while pressing it downwards.

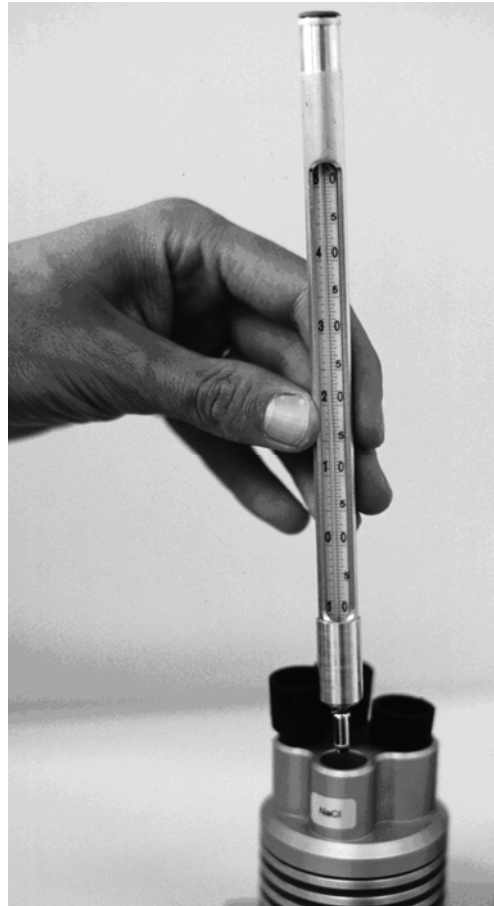

0606-172

Figure 9 During calibration, the thermometer is inserted into the 13.5 mm hole

When the thermometer is not in use or the calibrator is transferred from one place to another, place the thermometer in holders (Figure 10).

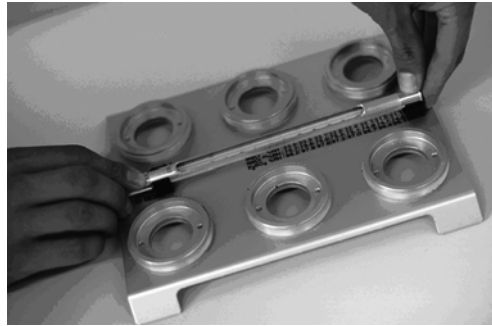

0606-173

Figure 10 Place the thermometer in holders when not in use

Calibration

Perform the calibration according to the following instructions:

- Leave the HMK15 calibrator and the probe at the calibration site for at least 30 minutes before starting the calibration in order to let the probe temperature stabilize to the room temperature.
- With lithium chloride it is not necessary to use the thermometer as the humidity reading changes only very slightly in the temperature range of +25 ... +30 °C. However, if you use it make sure that the sleeve is in the correct position and insert it into the 13.5 mm hole of the LiCl salt chamber.

NOTE

Handle the thermometer as little as possible and do not handle it by the measuring end. Press the thermometer downwards until it passes the O-rings. The thermometer is correctly in place when you feel a resistance while pressing it downwards.

- Take off the grid or filter protecting the sensor. Take care not to damage the sensor.
- Some 12 mm probes need a adapter fitting to fit into the 13.5 mm hole. Adapter fitting prevents sensor from soaking in the salt liquid. In case you need an adapter fitting, take off the grid or filter and replace it with the adapter fitting. Two adapter fittings are attached on the base plate of the HMK15, see Figure 1 on page 8.

CAUTION

Remember to check from the user's guide of your device if the adapter fitting is needed. If sensor accidentally soaks in salt liquid, remove it quickly and rinse with clean water. Let it dry before taking into use again.

- Insert the probe into a suitable hole of the LiCl salt chamber. Press it downwards until it passes the O-rings. The shorter the time the hole stays open before inserting the probe, the shorter the stabilization time required.
- Wait until the humidity reading stabilizes; this takes about 10 ... 30 minutes.
- Read the salt chamber temperature from the thermometer and then read the closest humidity value from the calibration table (Greenspan's Calibration Table on page 25, LiCl solution).
- Adjust the dry end (DRY, offset) to correspond to the value given in the calibration table.
- Insert the thermometer into the 13.5 mm hole of the NaCl salt chamber.

NOTE

When calibrating probes that are being used for long term measurements (over 1 hour) in high humidities (90 ... 100 %RH), use the K_2SO_4 salt as the high end reference.

- Insert the probe into a suitable hole of the NaCl (or K₂SO₄) salt chamber. The shorter the time the hole stays open before inserting the probe, the shorter the stabilization time required.
- Wait until the humidity reading stabilizes; this takes about 10 ... 30 minutes. Note that in high humidities the risk for errors increases. Therefore, the stabilization time should be longer (approximately 20 ... 40 minutes).
- Read the salt chamber temperature from the thermometer and then read the closest humidity value from the calibration table (Greenspan's Calibration Table below, NaCl or K₂SO₄ solution).
- Adjust the wet end (WET, gain) to correspond to the value given in the calibration table.

Greenspan's Calibration Table¹

C	LiCl	MgCl ₂	NaCl	K ₂ SO ₄
0	*	33.7 ± 0.3	75.5 ± 0.3	98.8 ± 1.1
5	*	33.6 ± 0.3	75.7 ± 0.3	98.5 ± 0.9
10	*	33.5 ± 0.2	75.7 ± 0.2	98.2 ± 0.8
15	*	33.3 ± 0.2	75.6 ± 0.2	97.9 ± 0.6
20	11.3 ± 0.3	33.1 ± 0.2	75.5 ± 0.1	97.6 ± 0.5
25	11.3 ± 0.3	32.8 ± 0.2	75.3 ± 0.1	97.3 ± 0.5
30	11.3 ± 0.2	32.4 ± 0.1	75.1 ± 0.1	97.0 ± 0.4
35	11.3 ± 0.2	32.1 ± 0.1	74.9 ± 0.1	96.7 ± 0.4
40	11.2 ± 0.2	31.6 ± 0.1	74.7 ± 0.1	96.4 ± 0.4
45	11.2 ± 0.2	31.1 ± 0.1	74.5 ± 0.2	96.1 ± 0.4
50	11.1 ± 0.2	30.5 ± 0.1	74.4 ± 0.2	95.8 ± 0.5

The numbers on the right in each column indicate the uncertainty of the reference humidity of the salt in that temperature.

1) Greenspan, L.: Journal of Research of the National Bureau of Standards - A Physics and Chemistry Vol. 81A, No. 1 January-February 1977, pp. 89-95

On-Site Calibrations and Transportation

The HMK15 calibrator is easily transferred from one place to another. Two O-rings seal the transit cover on the chamber. The optional transit bag helps to transport the calibrator so that chambers stay in the vertical position. Furthermore, the bag can be used for housing the calibrator during calibration.



0606-174

Figure 11 Optional Transit Bag for HMK15

When transferring the calibrator from one place to another, follow the instructions below:

- Turn the protective sleeve on the thermometer and place the thermometer in the holder.
- Replace chamber covers with transit covers. Press chamber covers on vacant chamber holders for transportation.
- During transportation, keep the calibrator so that the chambers stay as upright as possible. This way, very little salt solution gets on transit covers and cleaning is easier. The closer the transportation temperature is to the temperature of the calibration site, the shorter the time required for temperature stabilization. If the

transportation temperature is below +18 °C, the LiCl salt chamber should be transported separately to keep the solution warm.

- When the calibrator is at the calibration site, remove transit covers and fasten chamber covers on salt chambers. Close the holes with plugs.

NOTE

The plugs have three steps each of which is suitable for a certain hole diameter: the first step for the 12 mm, the second step for the 13.5 mm and the third step for the 18.5 mm hole.

- Clean the transit covers with a damp cloth and press them on vacant chamber holders.
- Take the thermometer off the holder, turn the sleeve the other way round and perform the calibration according to section Calibration on page 23.

In on-site calibrations it is important to allow enough time for the calibrator and probe temperatures to stabilize. Depending on the temperature differences between the transportation and the calibration site or between the probe removed from the process and the calibration site, a two point calibration takes about 0.5 ... 2 hours. If there are several frequently calibrated instruments at the same site, knowing the stabilization times is useful.

The following figure illustrates an example of temperature and humidity stabilization. In this example, an HMP233 probe has been transferred from a temperature of 75 °C (oven) to a suitable hole of the NaCl salt chamber; the calibrator is at room temperature. The figure shows that after 40 minutes, the humidity reading differs 0.2 %RH from the final reading.

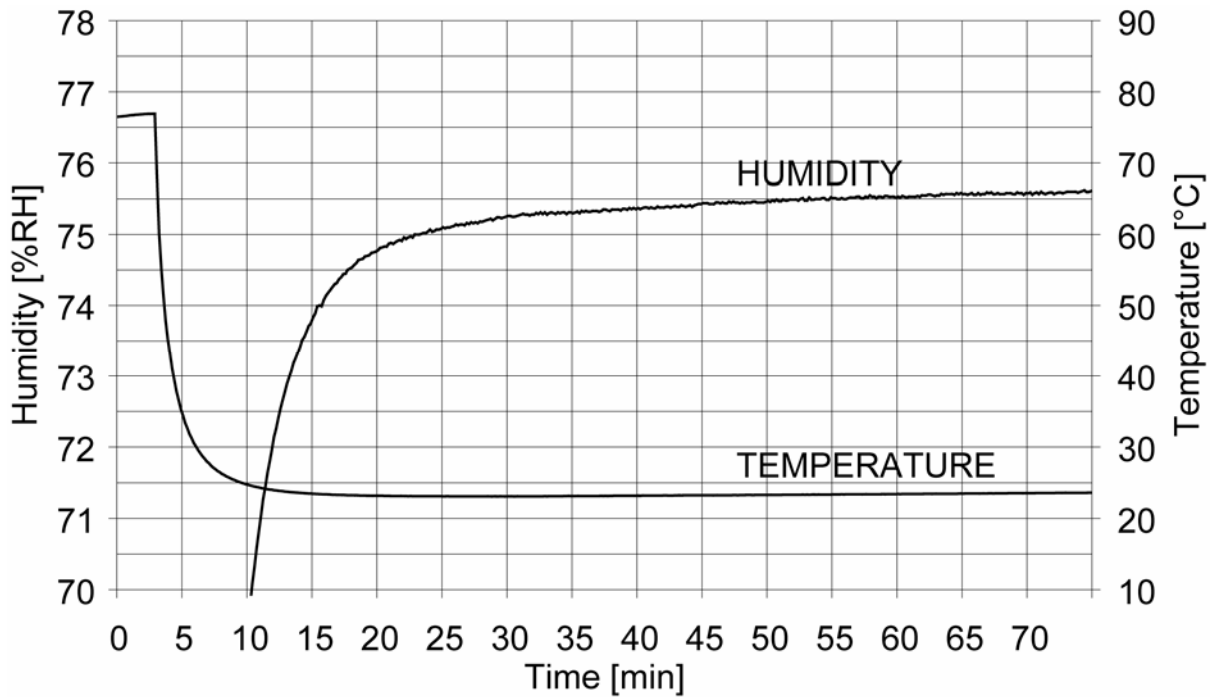

0606-175

Figure 12 An example of RH and T stabilization when the probe is removed from a process

In the following example, the transportation temperature of the calibrator (without the LiCl) is +5 °C; the calibrator is then transferred into room temperature. After this, an HMP233 probe that has been stored at room temperature, is inserted into a suitable hole of the NaCl salt chamber. The figure shows that after 40 minutes, the reading differs 1.4 %RH from the final reading.

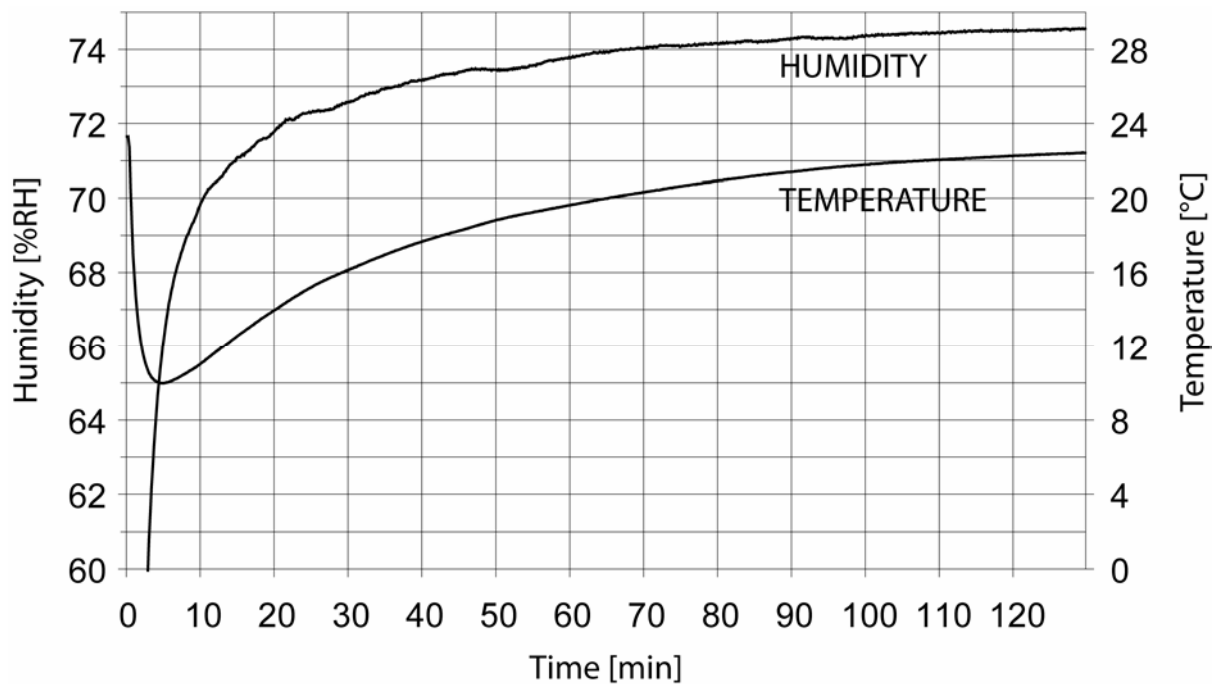

0606-177

Figure 13 An example of the RH and T stabilization when the transportation and calibration site temperatures are different

This page intentionally left blank.

CHAPTER 5

MAINTENANCE

Depending on the frequency of use and the general operating conditions, the salt solutions maintain their characteristics for 6 ... 12 months. After that, they must be replaced. A visual check should be performed at intervals of 2 ... 3 months. There must be a minimum of approximately 10% of undissolved salt at the bottom of the chamber (max. 90 %) and the salt must be clean, otherwise it must be reprepared. Please, note that the LiCl solution may crystallize on the surface. However, there may still be solution under the surface. Therefore, in such cases stir the solution and check it again the next day. It is advisable to keep a maintenance log which shows the dates of salt replacements and other maintenance procedures.

For correct calibration it is essential that salt chambers are tightly closed. Check the O-rings at each salt replacement. If they are damaged, replace them with new ones. The O-rings used are of the following types:

O-ring location	dimensions	type
measurement hole 12 mm	12 × 2.5 mm	NBR70
measurement hole 13.5 mm	13.5 × 2.5 mm	NBR70
measurement hole 18.5 mm	18.3 × 2.4 mm	NBR70
transit cover	41.2 v 3.0 mm	NBR70
chamber	50.0 × 2.0 mm	NBR70

This page intentionally left blank.

CHAPTER 6

SPARE PARTS AND ACCESSORIES

Order code	Description
19728HM	Mercury thermometer with calibration certificate
25130HM	Thermometer with red capillary liquid
19729HM	Ready-dosed LiCl salt package with calibration certificate
19730HM	Ready-dosed MgCl ₂ salt package with calibration certificate
19731HM	Ready-dosed NaCl salt package with calibration certificate
19732HM	Ready-dosed K ₂ SO ₄ salt package with calibration certificate
19746HM	Plug set
19766HM	Salt chamber
19767HM	Ion exchanged water
211302SP	Adapter fitting for 12 mm probes (spare part)
HM27032	Transit bag

This page intentionally left blank.

CHAPTER 7

TECHNICAL DATA

Operating temperature range +0 ... +50 °C

NOTE

If the LiCl solution is used or stored in temperatures below +18 °C, its equilibrium humidity changes permanently.

Accuracy:

lithium chloride LiCl	±1.0 %RH + Greenspan's uncertainty*
magnesium chloride MgCl ₂	±1.0 %RH + Greenspan's uncertainty*
sodium chloride NaCl	±1.4 %RH + Greenspan's uncertainty*
potassium sulphate K ₂ SO ₄	±1.5 %RH + Greenspan's uncertainty*

*) The uncertainty given in Greenspan's calibration table (on page 25) at the calibration temperature, for example the accuracy of LiCl salt at +20 °C is ±(1.0 + 0.3) %RH = ±1.3 %RH

Response time (probe and calibrator at the same temperature)	with Vaisala sensors typically 10 min (deviation of the final value < ± 1 %RH)
Accuracy of the thermometer: with mercury with red capillary liquid	± 0.3 °C ± 1 °C
Dimensions Materials	$0 \times 9 \times 23$ cm metal parts: anodised aluminium
Weight	1 kg without salt solutions

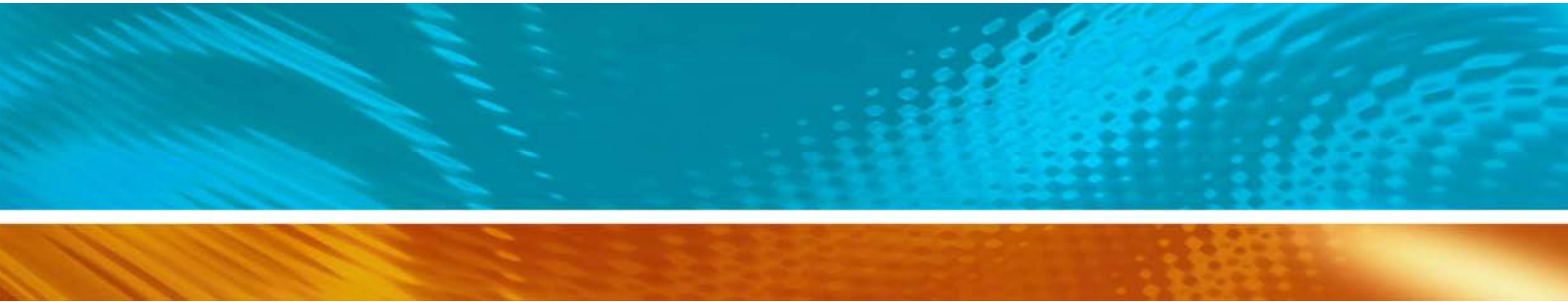

www.vaisala.com

