

HC900 for Boiler Control Applications

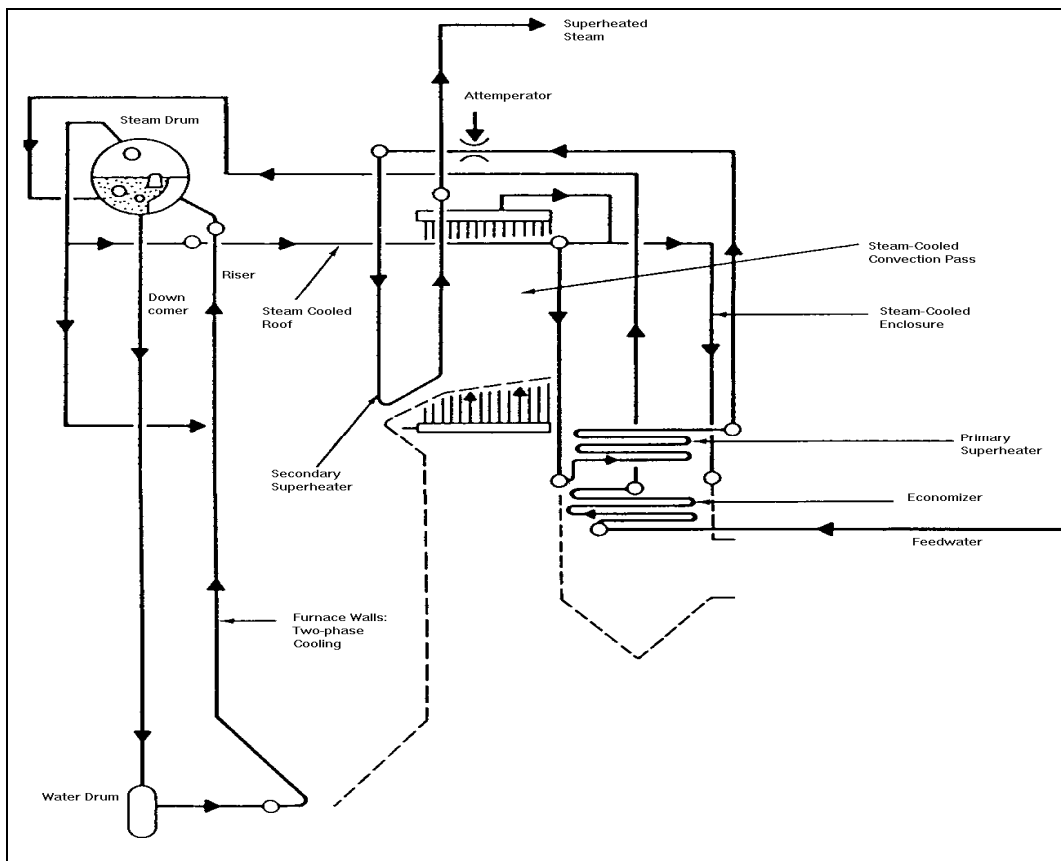

Background

Until recent years, only the largest boilers could justify sophisticated boiler controls. Now high fuel costs make it necessary to improve boiler efficiency and minimize costly steam losses and disturbances. Government regulations force compliance with air pollution and safety standards. Combustion controls have also become more important because boiler loads are being varied to meet needs rather than operating at full capacity and wasting fuel and steam.



Steam-Water Circulation System

Solution

Modern controls such as the HC900 Hybrid Controller can provide the most efficient boiler operation.

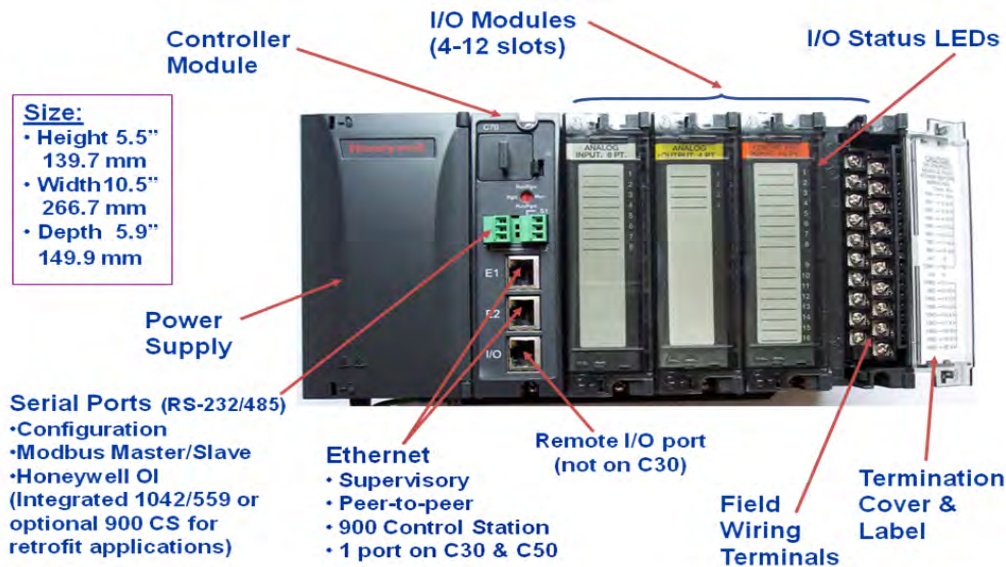

Fig. HC900 is currently pursuing the SIL2 certification and is expected to be certified in July 2012.

Drum Level Control. The steam drum is an integral part of a boiler. The vessel's primary function is to provide a surface area and volume near the top of the boiler where separation of steam from water can occur. It also provides a location for chemical water treatment, addition of feedwater, re-circulation water, and blowdown.

Blowdown removes residue and maintains a specified impurity level to reduce scale formation. Because these functions involve the continual addition and loss of material, the water-steam interface level is critical. Low level affects the re-circulation of water to the boiler tubes and reduces the water treatment effectiveness. High level reduces the surface area and can lead to water and dissolved solids entering the steam distribution system. The objective of the drum level control system is to maintain the water-steam interface at the specified level and provide a continuous mass balance by replacing every pound of steam with a pound of feedwater.

Types of Drum Level Control. There are 3 basic types of drum level control systems: single element, two element and three element. Their application depends upon specific boiler size and load changes.

The **Single Element System** is the simplest approach. It measures level and regulates feedwater flow to maintain the

level. This is only effective for smaller boilers supplying steady processes which have slow and moderate load changes.

The **Two Element System** uses two variables, drum level and steam flow to manipulate the feedwater flow. Steam flow load changes are fed forward to the feedwater valve providing an initial correction for load changes. The steam flow range and feedwater flow range are matched so that a one pound change in steam flow results in a one pound change in feedwater flow. This system is adequate for load changes of moderate speed and magnitude and can be applied to any size boiler. It does have two drawbacks. It cannot adjust for pressure or load disturbances in the feedwater system and cannot adjust for phasing interaction in the process because only the relatively slow responding drum level is controlled.

The **Three Element System** adds a third variable, feedwater flow rate to manipulate the feedwater control valve. This system provides close control during transient conditions because the two controllers minimize phasing interaction present in the two element approach. The feedwater control assures an immediate correction for feedwater disturbances. The drum level control provides trimming action. This system can handle large and rapid load changes and feedwater disturbances regardless of boiler capacity.

This approach is required on multiple boilers having a common feedwater supply. It is ideal for plants with both batch and

continuous processes where sudden and unpredictable steam

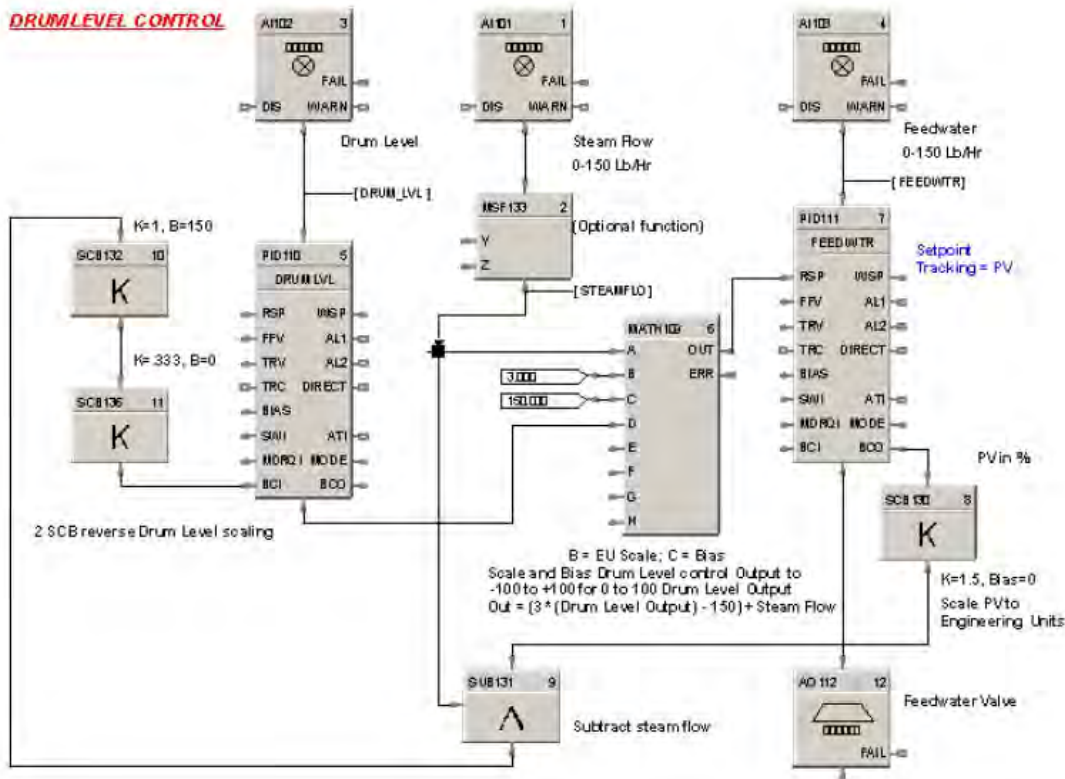

Figure 1

demand changes are common.

Figure 1 shows a Drum Level Control Solution implemented with the Hybrid Control Designer configuration software for the HC900 controller.

Fuel-Air Ratio Control: A fuel-air metering control system is essential for efficient combustion in boilers, furnaces, and other large fuel fired heating processes. There are 3 basic types of Fuel-Air Ratio Control systems: series metered system, parallel metered system, and cross limiting system.

The **Series Metered System** is fairly common where load changes are not large or common. Both fuel and air are metered. The steam pressure controller regulates the fuel flow that is measured, linearized and then used as the remote set point to the air-flow controller. This positions an air damper to maintain the specified ratio between the fuel and air. This system is adequate for near steady state conditions. However lags in response to load changes can result in temporary smoking, incomplete combustion and fuel-rich conditions.

The **Parallel Metered System** operates the fuel and air control controllers in parallel from a setpoint generated by the steam pressure controller. The setpoint signal is ratioed before being used as the setpoint to the air controller to establish the fuel-air proportions. This system relies on similar responses from both controllers to prevent improper fuel-air mixtures. This system is best applied to processes that experience relatively slow load changes.

The **Cross Limiting System** is used when large or frequent load changes are expected. This is a dynamic system that helps compensate for the different speed of response of the fuel valve and air damper. It prevents a “fuel-rich” condition and minimizes smoking and air pollution from the stack. The system is also known as a lead-lag system. When demand increases, a low-selector function blocks the signal, forcing the

air flow signal to become the setpoint to the fuel flow controller. A high selector passes the increase to the airflow controller's setpoint. This means fuel flow cannot increase until air flow has begun to increase, i.e. **air increase leads fuel increase**.

lags fuel decrease. This means a fuel rich condition is avoided, regardless of the direction of load change.

When demand decreases, the low selector passes the signal to the fuel flow controller setpoint. A high selector blocks the signal to the Air Controller and passes the fuel flow signal to the air flow controller setpoint. This means air flow cannot decrease until the fuel flow begins to drop hence **air decrease**

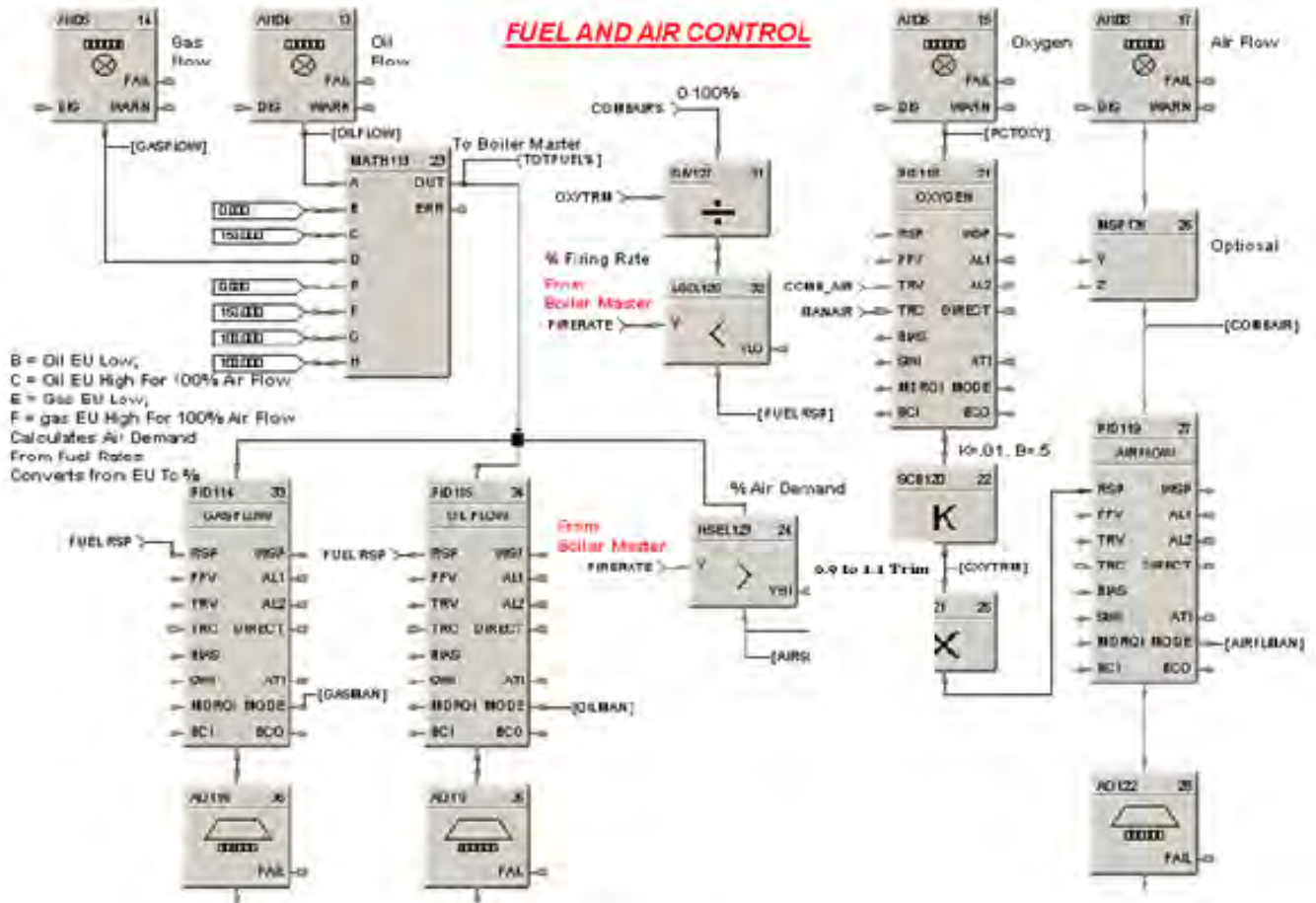

Figure 2

Figure 2 shows a Fuel-Air Ratio Control solution implemented with Hybrid Control Designer software for the HC900 Controller.

These diagrams above are just examples of how the function blocks could be used to implement Fuel-Air Ratio control and may not cover all the necessary details for your project so it would be advisable to contact your local automation engineers/experts to better guide you on the same.

stoichiometric combustion efficiency. Too much air results in energy lost up the stack. Insufficient air results in loss of heat generation and increased pollution due to incomplete fuel combustion. A certain amount of excess air is required to insure that complete combustion occurs within the combustion chamber and to compensate for delays in fuel-air ratio control action during load changes. In addition to improved efficiency,

Oxygen Trim. Automatic oxygen trim of the fuel-air ratio is used to reduce excess air and thereby excess oxygen to nearly

lower excess air helps reduce corrosion and air pollution by

minimizing the formation of undesired gases.

Boiler Efficiency vs Excess Oxygen - Gas Firing @ 25-30 kLb/Hr

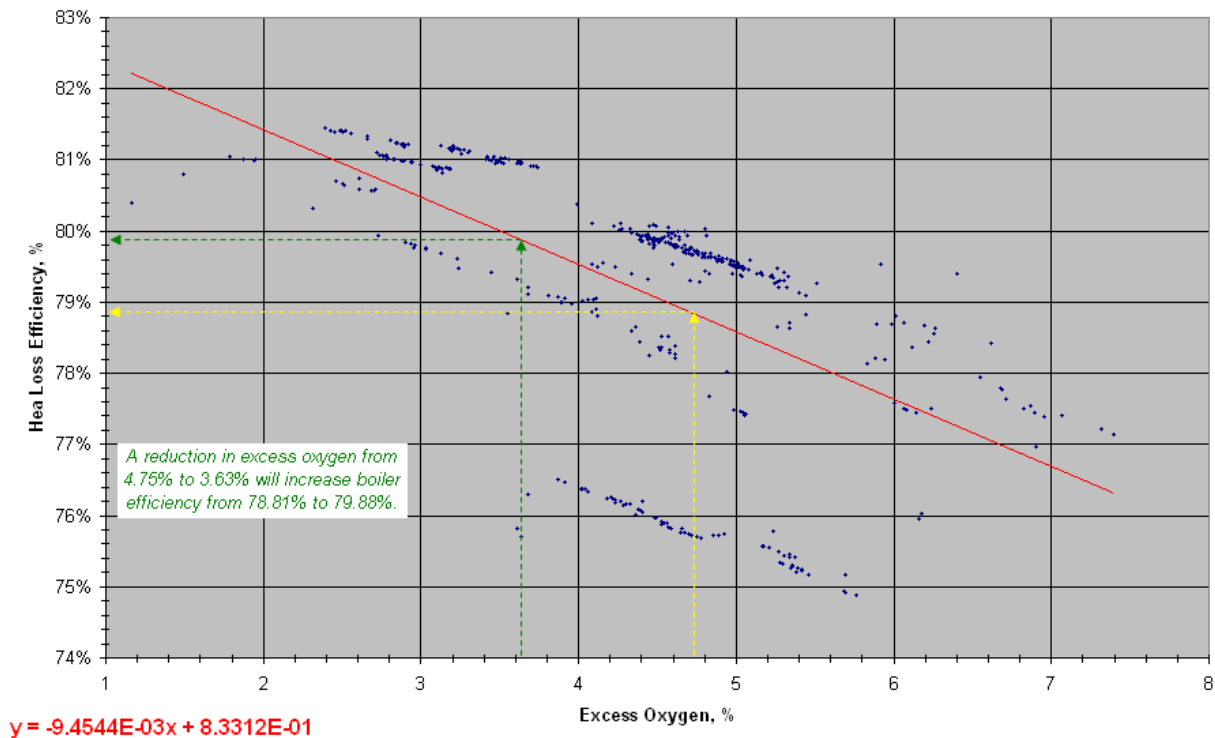

Figure 3 shows how a reduction in excess oxygen from 4.75% to 3.63% will increase boiler efficiency from 78.81% to 79.86%

The Honeywell HC900 provides all of the control functions required for drum level control, fuel-air ratio control and oxygen trim. In addition, the HC900 provides the following benefits when used in boiler control applications:

Integrated loop and logic control minimizes equipment cost

- Integrated control and operator interface simplifies troubleshooting
- The ability to trend and log process data for regulatory agency reporting
- A common configuration tool for both control and OI minimizing engineering costs.
- Autotuning and fuzzy overshoot protection for quick startup and proper control operation

Benefits to fuel cost savings & EPA emission requirements

Today the demand for energy is soaring, and steam is growing in importance in various industries such as power generation, industrial processing, space heating and emphasis is placed upon efficiency of boilers for steam generation. With steam generator size continually increasing even a modest efficiency gain means substantial savings. Approximately 75-80% of the cost for boiler operations is for fuel, so HC900 with its advanced function blocks and efficient controller plays a major role in fuel cost savings and increased steam output.

The US EPA has placed multiple regulations on emission for hazardous air pollutants through Industrial, commercial and Institutional boilers. These regulations promotes public health and air quality by reducing emissions of the hazardous air pollutants listed in section 112(b)(1) of the Clean air act. A good control system must be in place to handle minor mishaps that can take place during operations and it is extremely important to purchase a reliable process controller which will monitor the oxygen trip on Fuel-air ratio to reduce excess air

and minimize loss of heat generation and pollution through incomplete combustion.

Implementation

Overview: The HC900 Hybrid Controller consists of a panel-mounted controller connected to a dedicated Operator Interface (OI). All field signals terminate at the controller. The controller has universal analog inputs, analog outputs and a wide variety of digital input and output types. This controller will provide all the boiler control functions. The boiler related functions are provided through function blocks in the Hybrid Control designer software which is used to configure the controller.

Configuration: The Hybrid Control Designer configuration software provides advanced configuration techniques to allow a variety of strategies to be easily implemented. The run-mode configuration monitoring and editing capability allows these strategies to be tested and refined as process knowledge is gained. There are various other features such as on-line monitoring for debugging and setup, redundancy capability of inputs and controller/network diagnostics which make it a very powerful controller.

Operation: The complete operation can be monitored and controlled from the easy to use displays of the 900 CS interface. The 900 Control station can be configured using our tool called as Station Designer Software. The 900 Control station has Standard & Custom Graphic Displays as well as pre-built widgets which makes configuration easy. The 900 control station can also be used for trending and data logging, alarm/event history, email notifications, recipe selections and much more.



900 Control Station

Data Storage: The data storage feature of the 900 Control Station can be used to record process information during operation to an expandable compactflash card slot which has protected access behind the panel and it allows for increased data logging capacity with history, the optional flash memory card will also help with screen printing, web access to data, FTP transfers, and custom web page support.

Experion HS and HC900

Experion HS is a powerful software platform that incorporates innovative applications for Human Machine Interface (HMI) and Supervisory Control and Data Acquisition (SCADA). It is comprised of a subset of Honeywell's Experion PKS components and is specifically packaged to provide a targeted and robust system for small to medium automation projects.

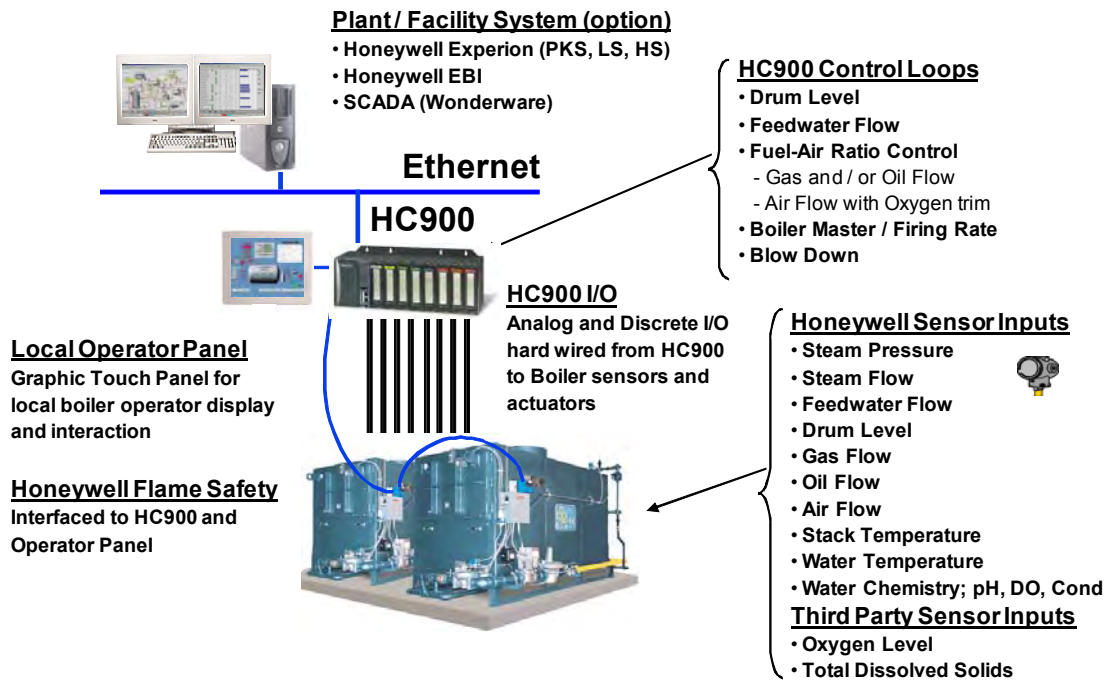

For more information

To learn more about HC900 PLC systems, visit

www.honeywellprocess.com

Or contact your Honeywell Channel Partner

Fluidic Limited, UK

Motherwell: 01698 327372

Warrington: 01925 572401

www.fluidic-ltd.co.uk