

**STT 750 SMARTLINE
Temperature Transmitter
User's Manual**

**34-TT-25-13
Revision 1
August 2015**

Copyrights, Notices and Trademarks

© Copyright 2015 by Honeywell, Inc.

Revision 1, August 2015

While the information in this document is presented in good faith and believed to be accurate, Honeywell disclaims any implied warranties of merchantability and fitness for a particular purpose and makes no express warranties except as may be stated in the written agreement with and for its customers. In no event is Honeywell liable to anyone for any indirect, special, or consequential damages. The information and specifications in this document are subject to change without notice.

Honeywell, TDC 3000, SFC, Smartline, PlantScape, Experion PKS, and TotalPlant are registered trademarks of Honeywell International Inc. Other brand or product names are trademarks of their respective owners.

**Honeywell Process Solutions
1250 W Sam Houston Pkwy S
Houston, TX 77042**

About This Manual

This manual is a detailed *how to* reference for installing, piping, wiring, configuring, starting up, operating, maintaining, calibrating, and servicing Honeywell's family of STT 750 Temperature Transmitters. Users who have a Honeywell STT 750 SmartLine Temperature Transmitter configured for HART protocol are referred to the *STT 750 SmartLine Series HART Option User's Manual*, document number 34-TT-25-15.

The configuration of your Transmitter depends on the mode of operation and the options selected for it with respect to operating controls, displays and mechanical installation. This manual provides detailed procedures to assist first-time users, and it further includes keystroke summaries, where appropriate, as quick reference or refreshers for experienced personnel.

To digitally integrate a Transmitter with one of the following systems:

- For the Experion PKS, you will need to supplement the information in this document with the data and procedures in the *Experion Knowledge Builder*.
- For Honeywell's TotalPlant Solutions (TPS), you will need to supplement the information in this document with the data in the *PM/APM SmartLine Transmitter Integration Manual*, which is supplied with the TDC 3000 book set. (TPS is the evolution of the TDC 3000).

Release Information:

STT 750 SmartLine Temperature Transmitter User Manual, Document # 34-TT-25-13,
Rev 1, August 2015 1st Release

References

The following list identifies publications that may contain information relevant to the information in this document.

STT 750 SmartLine Temperature Transmitter Quick Start Installation Guide, Document # 34-TT-25-14

SmartLine Temperature Transmitter with HART Communications Options Safety Manual, # 34-TT-25-05

STT 750 SmartLine Temperature Transmitter HART Option User's Manual, Document # 34-TT-25-15

MC Toolkit User Manual, for MCT404, Document # 34-ST-25-50

PM/APM SmartLine Transmitter Integration Manual, Document # PM 12-410

STT 750 Series Temperature, Transmitter, Agency IS Control Drawing 50091227

Smart Field Communicator Model STS 103 Operating Guide, Document # 34-ST-11-14

Patent Notice

The Honeywell STT 750 SmartLine Temperature Transmitter family is covered by one or more of the following U. S. Patents: 5,485,753; 5,811,690; 6,041,659; 6,055,633; 7,786,878; 8,073,098; and other patents pending.

Support and Contact Information

For Europe, Asia Pacific, North and South America contact details, refer to the back page of this manual or the appropriate Honeywell Solution Support web site:

Honeywell Corporate www.honeywellprocess.com

Honeywell Process Solutions <https://www.honeywellprocess.com/smartline-temperature/>











Training Classes <http://www.automationcollege.com>



Telephone and Email Contacts

Area	Organization	Phone Number
United States and Canada	Honeywell Inc.	1-800-343-0228 Customer Service 1-800-423-9883 Global Technical Support
Global Email Support	Honeywell Process Solutions	ask-ssc@honeywell.com

Symbol Descriptions and Definitions

The symbols identified and defined in the following table may appear in this document.

Symbol	Definition
	ATTENTION: Identifies information that requires special consideration.
	TIP: Identifies advice or hints for the user, often in terms of performing a task.
CAUTION	Indicates a situation which, if not avoided, may result in equipment or work (data) on the system being damaged or lost, or may result in the inability to properly operate the process.
	CAUTION: Indicates a potentially hazardous situation which, if not avoided, may result in minor or moderate injury. It may also be used to alert against unsafe practices. CAUTION symbol on the equipment refers the user to the product manual for additional information. The symbol appears next to required information in the manual.
	WARNING: Indicates a potentially hazardous situation, which, if not avoided, could result in serious injury or death. WARNING symbol on the equipment refers the user to the product manual for additional information. The symbol appears next to required information in the manual.
	WARNING, Risk of electrical shock: Potential shock hazard where HAZARDOUS LIVE voltages greater than 30 Vrms, 42.4 Vpeak, or 60 VDC may be accessible.
	ESD HAZARD: Danger of an electro-static discharge to which equipment may be sensitive. Observe precautions for handling electrostatic sensitive devices.
	Protective Earth (PE) terminal: Provided for connection of the protective earth (green or green/yellow) supply system conductor.
	Functional earth terminal: Used for non-safety purposes such as noise immunity improvement. NOTE: This connection shall be bonded to Protective Earth at the source of supply in accordance with national local electrical code requirements.
	Earth Ground: Functional earth connection. NOTE: This connection shall be bonded to Protective Earth at the source of supply in accordance with national and local electrical code requirements.
	Chassis Ground: Identifies a connection to the chassis or frame of the equipment shall be bonded to Protective Earth at the source of supply in accordance with national and local electrical code requirements.
continued	

Symbol	Description
	<p>The Factory Mutual[®] Approval mark means the equipment has been rigorously tested and certified to be reliable.</p>
	<p>The Canadian Standards mark means the equipment has been tested and meets applicable standards for safety and/or performance.</p>
	<p>The Ex mark means the equipment complies with the requirements of the European standards that are harmonized with the 94/9/EC Directive (ATEX Directive, named after the French "ATmosphere EXplosible").</p>

Contents

1.	Introduction	1
1.1.	Overview	1
1.2.	Features and Options	1
1.2.1.	Physical Characteristics	1
1.2.2.	Functional Characteristics	2
1.3.	STT 750 SmartLine Transmitter NamePlate	3
1.4.	Safety Certification Information	3
1.5.	Transmitter Adjustments	3
1.6.	Display	4
1.7.	Optional 3-Button Assembly	4
2.	Application Design	5
2.1.	Overview	5
2.2.	Safety	5
2.2.1.	Accuracy	5
2.2.2.	Diagnostic Messages	5
3.	Installation and Startup	7
3.1.	Installation Site Evaluation	7
3.2.	Honeywell MC Toolkit	7
3.3.	Display Installation Precautions	7
3.4.	Mounting STT 750 SmartLine Temperature Transmitters	8
3.4.1.	Summary	8
3.4.2.	Mounting Dimensions	9
3.4.3.	Bracket Mounting Procedure	9
3.5.	Wiring a Transmitter	10
3.5.1.	Loop Power Overview	10
3.5.2.	Wiring Variations	12
3.5.3.	Loop Wiring Procedure	12
3.5.4.	Grounding and Lightning Protection	13
3.5.5.	Supply Voltage Limiting Requirements	13
3.5.6.	Process Sealing	13
3.5.7.	Explosion-Proof Conduit Seal	13
3.5.8.	Input Sensor Wiring	14
3.6.	Startup	15
3.6.1.	Overview	15
3.6.2.	Startup Tasks	15
3.6.3.	Output Check Procedures	15
3.6.4.	Constant Current Source Mode Procedure	16
4.	Operation	17
4.1.	Overview	17
4.2.	Three-Button Operation	17
4.2.1.	Menu Navigation	18
4.2.2.	Data Entry	18
4.2.3.	Editing a Numeric Value	19
4.2.4.	Selecting a new setting from a list of choices	19
4.2.5.	The Display Menu	20

4.3.	Three Button Operation with no Display Installed	23
4.3.1.	Zero Adjustment	23
4.3.2.	Span Adjustment	23
4.4.	Changing the Default Failsafe Direction.....	24
4.4.1.	Procedure to Establish Failsafe Operation	24
4.5.	Monitoring the Display	26
4.5.1.	Display	26
5.	Maintenance	27
5.1.	Overview	27
5.2.	Preventive Maintenance Practices and Schedules.....	27
5.3.	Replacing the Communication Module	27
6.	Calibration.....	31
6.1.	Recommendations for Transmitter Calibration.....	31
6.2.	Calibration Procedures	31
7.	Troubleshooting	33
7.1.	Overview	33
7.2.	Critical Diagnostics Screens	33
7.2.1.	Fault Conditions and Recommended Corrective Actions	33
8.	Parts List	35
8.1.	Overview	35
Appendix A. PRODUCT CERTIFICATIONS		39
9.	Appendix B – Security.....	51
8.2.	How to report security vulnerability	51
Glossary		52

List of Figures

Figure 1 – STT 750 Major Assemblies	2
Figure 2 – Electronics Housing Components	2
Figure 3 – Typical STT 750 NamePlate.....	3
Figure 4 – Mounting Brackets.....	8
Figure 5 – Angle Mounting Brackets	8
Figure 6 – Pipe Mounting Bracket Secured to a Horizontal or Vertical Flat Pipe	9
Figure 7 - Pipe Mounting Bracket secured to a Horizontal or Vertical Angle Pipe.....	10
Figure 8 – HART Transmitter Operating Ranges	10
Figure 9 – Transmitter 9-Screw Terminal Board and Grounding Screw	11
Figure 10 – STT 750 Thermocouple, RTD, mV, ohm and Volt Connections	14
Figure 11 – Current Loop Test Connections	16
Figure 12 - Three-Button Option.....	17
Figure 13 – Locating the Failsafe and Write Protect Jumpers.....	25
Figure 14 – Display with Process Variable Format.....	26
Figure 15 – PWA Replacement.....	27
Figure 16 – Pipe and Wall Bracket Parts.....	36
Figure 17 – Electronic Housing, Display End.....	37
Figure 18 – Electronic Housing, Terminal Block End	38

List of Tables

Table 1 – Features and Options.....	1
Table 2 – Available Display Characteristics.....	4
Table 3 – STT 750 Standard Critical Diagnostics Messages.....	6
Table 4 – STT 750 Standard Non-Critical Diagnostics Messages.....	6
Table 5 – Three-Button Option Functions.....	18
Table 6 – Three-Button Data Entry.....	19
Table 7 – The Display Menus.....	20
Table 8 – HART Failsafe and Write Protect Jumpers.....	25
Table 9 – Fault Conditions and Recommended Corrective Actions.....	33
Table 10 – Summary List of Recommended Spare Parts.....	35
Table 11 – Pipe and Wall Bracket Parts.....	37
Table 12 – Transmitter Major Assemblies.....	37

1. Introduction

1.1. Overview

This section is an introduction to the physical and functional characteristics Honeywell’s family of STT 750 SmartLine Temperature Transmitters.

1.2. Features and Options

The STT 750 SmartLine Temperature Transmitter is available in a variety of models for measuring Thermocouples, RTDs, millivolts, Volts and Ohm. [Table 1](#) lists the protocols, human-machine interface (HMI), materials, approvals, and mounting bracket options for the STT 750.

Table 1 – Features and Options

Feature/Option	Standard/Available Options
Communication Protocols	HART version 7
Human-Machine Interface (HMI)	Digital display
	Three-button programming (optional)
	Display language: English only
Calibration	Single
Approvals (See Appendix A for details.)	ATEX, CSA, FM, IECEx
Mounting Brackets	Angle and flat pipe mounting and wall mounting brackets in carbon steel and 316 stainless steel.

1.2.1. Physical Characteristics

As shown in [Figure 1](#), the STT 750 is packaged in one major assembly: the Electronics Housing. The elements in the Electronic Housing are connected to the process sensors, measure the process variables, respond to setup commands and execute the software and protocol for the different temperature measurement types. [Figure 2](#) shows the assemblies in the Electronics Housing with available options.

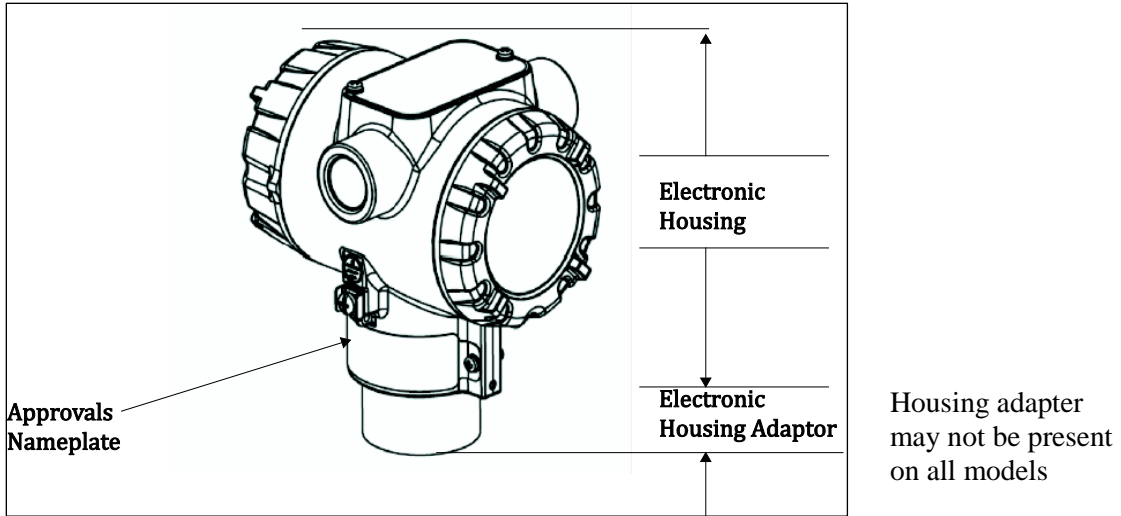

Figure 1 – STT 750 Major Assemblies

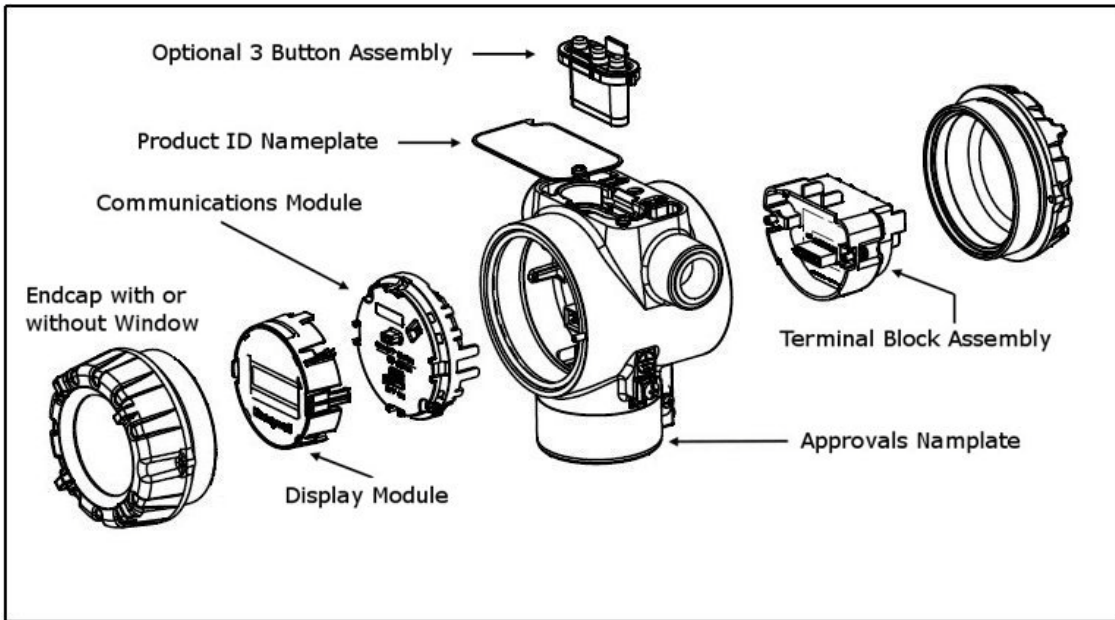

Figure 2 – Electronics Housing Components

1.2.2. Functional Characteristics

The Transmitter measures process Temperature and outputs a signal proportional to the measured process variable (PV), including 4 to 20mA.

An optional 3-button assembly is available to set up and make adjustments to the Transmitter. In addition, a Honeywell Multi-Communication (MC) Toolkit (not supplied with the Transmitter) can facilitate setup and adjustment procedures.

1.3. STT 750 SmartLine Transmitter NamePlate

The Transmitter nameplate mounted on the bottom of the electronics housing (see [Figure 1](#)) lists its model number, physical configuration, electronics options, accessories, certifications, and manufacturing specialties. [Figure 3](#) is an example of a typical Temperature Transmitter nameplate. The model number format consists of a Key Number with several table selections.

Key	I	II	III	IV	V	VI	VII	VIII	IX	
STT750	-	-	-	-	-	-	-	-	-	XXXX

Figure 3 –Typical STT 750 NamePlate

You can readily identify the series and basic Transmitter type from the key number. The letter in the third digit represents one of these basic transmitter types:

- T = Temperature

For a complete selection breakdown, refer to the appropriate Specification and Model Selection Guide provided as a separate document.

1.4. Safety Certification Information

An “approvals” nameplate is located on the bottom of the Electronics Assembly; see [Figure 1](#) for exact location. The approvals nameplate contains information and service marks that disclose the Transmitter compliance information. Refer to [Appendix A](#) of this document for safety certification requirements and details.

1.5. Transmitter Adjustments

Span adjustments are possible in STT 750 SmartLine Temperature Transmitters with the optional three-button assembly located at the top of the Electronic Housing (see [Figure 2](#)).

The user can also use the Honeywell MC Toolkit or other third-party hand-held to make any adjustments to an STT 750 SmartLine Temperature Transmitter.

1.6. Display

Table 2 – Available Display Characteristics

Display	<ul style="list-style-type: none">• Suitable for basic process needs• 360° rotation in 90° increments• 8 configurable screens• 2 lines, 16 characters• Standard units of measurement: °F, °C, °R, K, Ω, mV & %• Diagnostic messaging
---------	---

1.7. Optional 3-Button Assembly

The optional 3-Button Assembly is located under the nameplate and provides the following features and capabilities:

- Increment, decrement, and enter key functions.
- With the menu-driven display:
 - Comprehensive on-screen menu for navigation.
 - Transmitter configuration.
 - Transmitter calibration.
 - Display configuration.
 - Set span parameters.
 - Viewing transmitter parameters

2. Application Design

2.1. Overview

This section discusses the considerations involved with deploying a Honeywell STT 750 SmartLine Temperature Transmitter in a process system. The following areas are covered:

- Safety
- Input and output data
- Reliability
- Environmental limits
- Installation considerations
- Operation and maintenance\
- Repair and replacement

2.2. Safety

2.2.1. Accuracy

The STT 750 SmartLine Temperature Transmitter (Transmitter) measures the temperature of a process and reports the measurement to a receiving device. Refer to STT 750 Specification, 34-TT-03-16.

2.2.2. Diagnostic Messages

Transmitter standard diagnostics are reported in the two basic categories listed in [Table 3](#). Problems detected as critical diagnostics drive the analog output to the programmed burnout level for HART. Problems detected as non-critical diagnostics may affect performance without driving the analog output to the programmed burnout level (for HART). Informational messages (not listed in [Table 3](#)) report various Transmitter status or setting conditions. The messages listed in [Table 3](#) are specific to the Transmitter, exclusive of those associated with HART protocols. HART diagnostic messages are listed and described in the *STT 750 SmartLine Temperature Transmitter HART Option User Manual*, document number 34-TT-25-15.

Table 3 – STT 750 Standard Critical Diagnostics Messages

Critical Diagnostics (Failure Conditions)
Temperature Sensor Module Failure
Communication Module Failure
Sensor Comm. Timeout
Input Fault

Table 4 – STT 750 Standard Non-Critical Diagnostics Messages

Non-Critical Diagnostics (Warning Conditions)
Excess Cal Correct (Excess LRV Correct and/or Span correct for Sensor Input)
Input Out of Range (Sensor Input Under Range or Over Range)
Sensor Module Over Temperature
Cold Junction Out of Range Error
Sensor Input Open
Sensor Input TB6 Open
No Factory Calibration
Supply voltage Fault (External Supply voltage Fail)
Communication Module Over Temperature
No DAC compensation
Unreliable communication between Sensor and Comm Modules
Display NVM fault
Internal Power failure for Communication Module

3. Installation and Startup

3.1. Installation Site Evaluation

Evaluate the site selected for the STT 750 SmartLine Transmitter installation with respect to the process system design specifications and Honeywell's published performance characteristics for your particular model. Some parameters that you may want to include in your site evaluation are:

- Environmental Conditions:
 - Ambient Temperature
 - Relative Humidity
- Potential Noise Sources:
 - Radio Frequency Interference (RFI)
 - Electromagnetic Interference (EMI)
- Vibration Sources
 - Pumps
 - Motorized System Devices (e.g., pumps)
 - Valve Cavitation
- Process Parameters
 - Temperature
 - Maximum Sensor Input Ratings

3.2. Honeywell MC Toolkit

In preparation for post-installation processes, refer to the *MC Toolkit (MCT404) User Manual*, Document # 34-ST-25-50, for battery conditioning and device operation and maintenance information.

3.3. Display Installation Precautions

Temperature extremes can affect display quality. The display can become unreadable at temperature extremes; however, this is only a temporary condition. The display will again be readable when temperatures return to within operable limits.

The display update rate may increase at cold temperature extremes, but as with readability, normal updating resumes when temperatures are within limits for full operability.

3.4. Mounting STT 750 SmartLine Temperature Transmitters

3.4.1. Summary

Transmitter models can be attached to a two-inch (50 millimeter) vertical or horizontal pipe using Honeywell's optional angle brackets.

Honeywell's optional wall mounting bracket is also shown below:

Figure 4 and Figure 5 shows typical bracket-mounted installations.

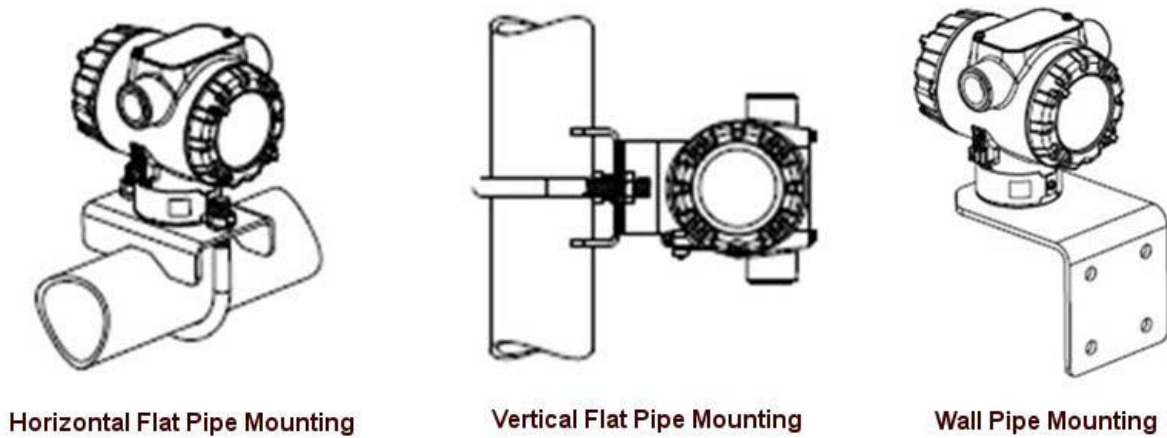

Figure 4 – Mounting Brackets

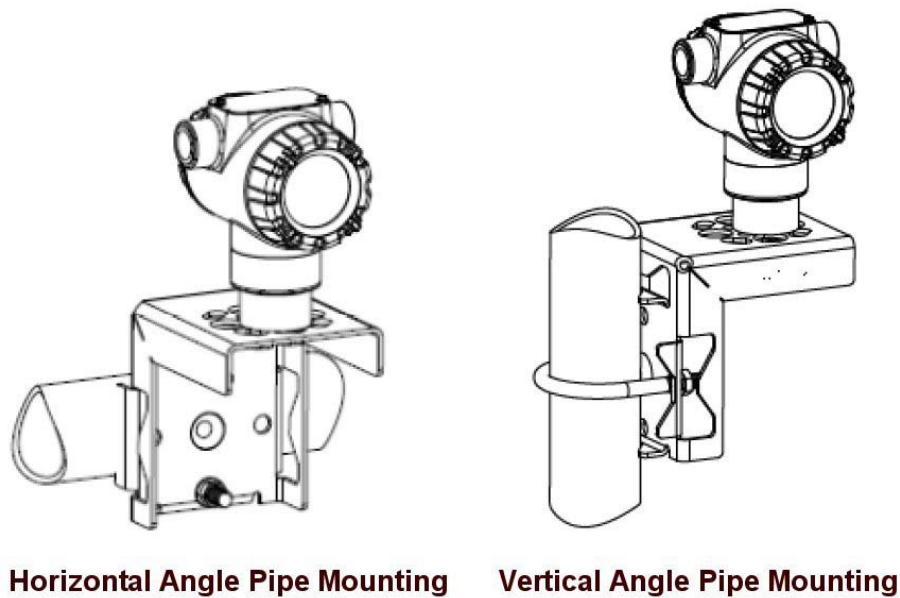

Figure 5 – Angle Mounting Brackets

3.4.2. Mounting Dimensions

Refer to Honeywell drawing number 50094836 for detailed dimensions of the transmitter assembly. Abbreviated overall dimensions are also shown on the Specification Sheets for the transmitter models. This section assumes that the mounting dimensions have already been taken into account and the mounting area can accommodate the Transmitter.

Refer to Honeywell drawing numbers 50095917 (Flat Pipe Mount), 50124813 (Angle Pipe Mount) and 50095918 (Wall Mount) for detailed mounting specifications.

3.4.3. Bracket Mounting Procedure

1. Align the two mounting holes in the transmitter with the two slots in the mounting bracket and assemble the (2) M8 hex cap screws, (2) lockwashers and (2) flat washers provided. Rotate transmitter assembly to the desired position and torque the M8 hex cap screws to 27,0 Nm/20,0 Lb-ft maximum.
2. Pipe Mount Option: Refer to [Figure 6](#) and [Figure 7](#). Position the bracket on a 2-inch (50.8 mm) horizontal or vertical pipe, and install a “U” bolt around the pipe and through the holes in the bracket. Secure the bracket with the nuts, flat washers and lock washers provided.
3. Wall Mount Option: Position the bracket on the mounting surface at the desired location and secure the bracket to the mounting surface using the appropriate hardware (Wall mounting hardware requirements to be determined and supplied by the end user).

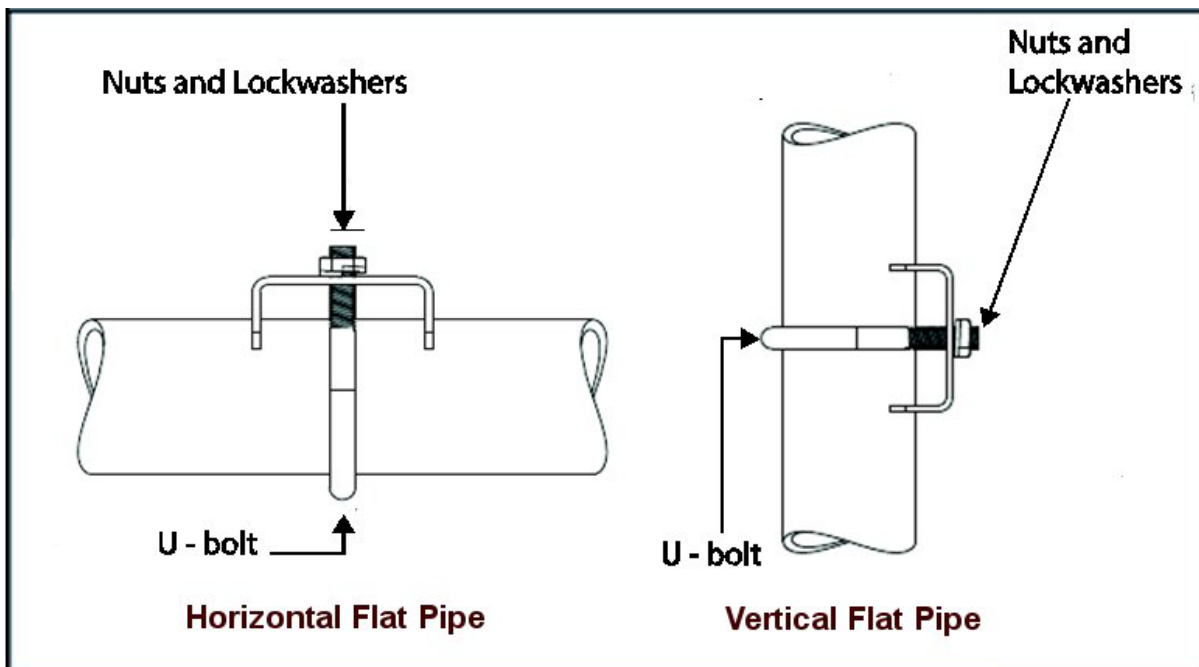

Figure 6 – Pipe Mounting Bracket Secured to a Horizontal or Vertical Flat Pipe

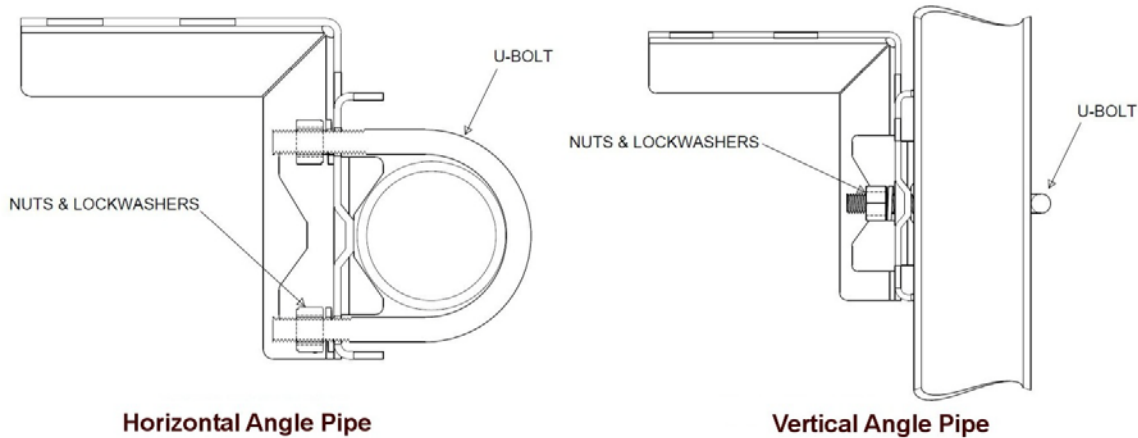

Figure 7 - Pipe Mounting Bracket secured to a Horizontal or Vertical Angle Pipe

3.5. Wiring a Transmitter

3.5.1. Loop Power Overview

The transmitter is designed to operate in a two-wire power/current loop with loop resistance and power supply voltage within the HART operating range shown in Figure 8.

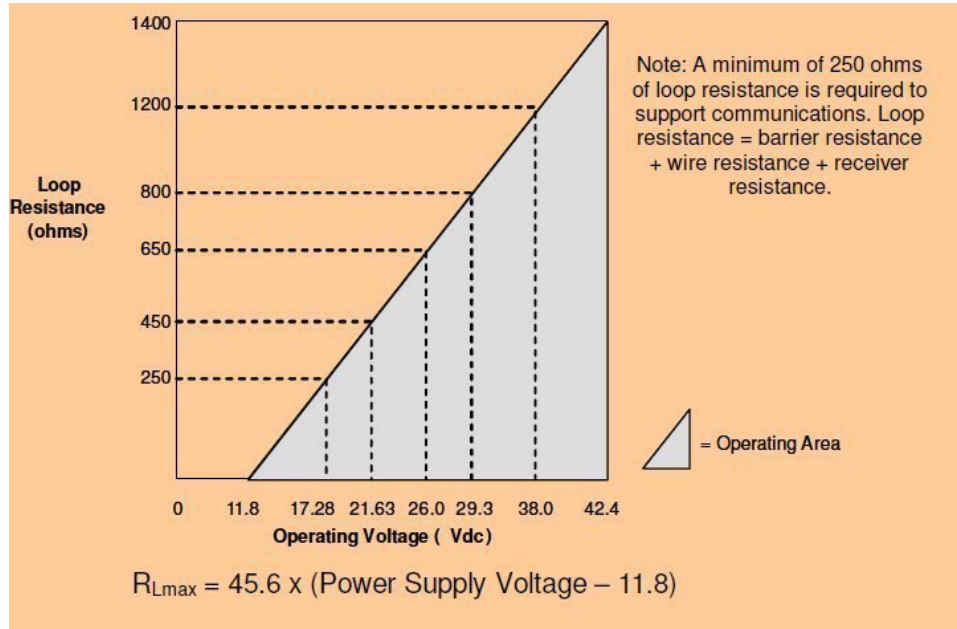

Figure 8 – HART Transmitter Operating Ranges

Loop wiring is connected to the Transmitter by simply attaching the positive (+) and negative (-) loop wires to the positive (+) and negative (-) terminals on the Transmitter terminal block in the Electronics Housing. Connect the Loop Power wiring shield to earth ground only at the power supply end. **Note** that the Transmitter is not polarity-sensitive.

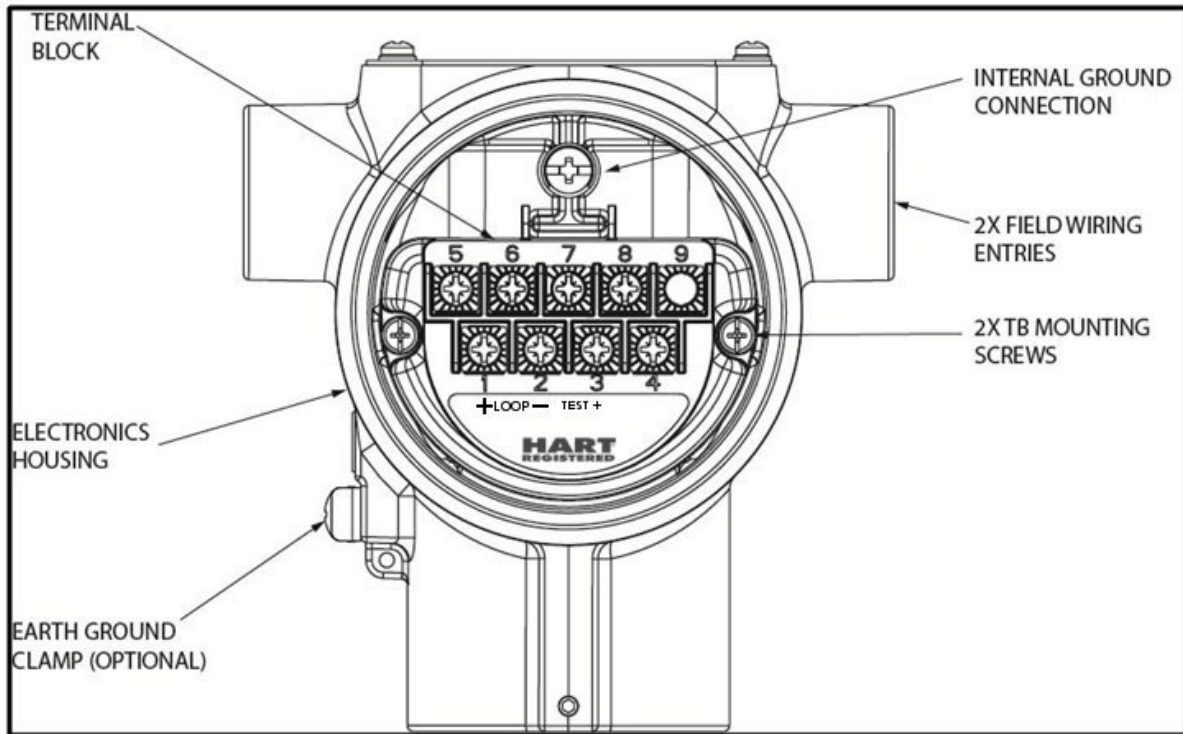

Figure 9 – Transmitter 9-Screw Terminal Board and Grounding Screw

As shown in [Figure 9](#), each Transmitter has an internal terminal to connect it to earth ground. Optionally, a ground terminal can be added to the outside of the Electronics Housing. Grounding the Transmitter for proper operation is required, as doing so tends to minimize the possible effects of noise on the output signal and affords protection against lightning and static discharge. An optional lightning terminal block can be installed in place of the non-lightning terminal block for Transmitters that will be installed in areas that are highly susceptible to lightning strikes. As noted above, the Loop Power wiring shield should only be connected to earth ground at the power supply end.
 Note: Pin 9 is not used.

 Wiring must comply with local codes, regulations and ordinances. Grounding may be required to meet various approval body certification, for example CE conformity. Refer to [Appendix A](#) of this document for details.

Note: Terminal #3 is for loop test

For HART the Transmitter is designed to operate in a two-wire power/current loop with loop resistance and power supply voltage within the operating range; see [Figure 8](#). With an optional remote meter, the voltage drop for this must be added to the basic power supply voltage requirements to determine the required Transmitter voltage (V_{XMTR}) and maximum loop resistance ($R_{LOOP MAX}$). Additional consideration is required when selecting intrinsic safety barriers to ensure that they will supply at least minimum Transmitter voltage ($V_{XMTR MIN}$), including the required 250 ohms of resistance (typically within the barriers) needed for digital communications.

Transmitter loop parameters are as follows:

$R_{\text{LOOP MAX}}$ = maximum loop resistance (barriers plus wiring) that will allow proper Transmitter operation and is calculated as $R_{\text{LOOP MAX}} = (V_{\text{SUPPLY MIN}} - V_{\text{XMTR MIN}} - V_{\text{SM}}) \div 21.8 \text{ mA}$.

In this calculation:

$$V_{\text{XMTR MIN}} = 11.8 \text{ V (HART)} \quad V_{\text{SM}} = 2.3 \text{ V, remote meter}$$

Note that V_{SM} should only be considered if a remote meter will be connected to the transmitter.

The positive and negative loop wires are connected to the positive (+) and negative (-) terminals on the terminal block in the Transmitter Electronics Housing.

Barriers can be installed per Honeywell's instructions for Transmitters to be used in intrinsically safe applications.

3.5.2. Wiring Variations

The above procedures are used to connect power to a Transmitter. For loop wiring, sensor wiring and external wiring, detailed drawings are provided for Transmitter installation in non-intrinsically safe areas and for intrinsically safe loops in hazardous area locations.

3.5.3. Loop Wiring Procedure

1. See [Figure 9](#), above, for parts locations. Loosen the end cap lock using a 1.5 mm Allen wrench.
2. Remove the end cap cover from the terminal block end of the Electronics Housing.
3. Feed loop power leads through one end of the conduit entrances on either side of the Electronics Housing. The Transmitter accepts up to 16 AWG wire.
4. Connect the positive loop power lead to the positive (+) terminal #1 and the negative loop power lead to the negative (-) terminal #2. Note that the Transmitter is not polarity-sensitive.
5. Feed sensor input wires through the second housing conduit entry and connect wires per [Figure 9](#).
6. Replace the end cap, and secure it in place.

3.5.4. Grounding and Lightning Protection

Connect a wire from the Earth Ground Clamp or to the Internal Ground Connection (see [Figure 9](#)) to Earth Ground to make the protection effective. Use a size 8 AWG or (8.37mm²) bare or green covered wire for this connection.

For ungrounded Thermocouple, mV, RTD or ohm inputs connect the input wiring shield(s) to the Internal Ground Connection shown in [Figure 9](#).

For grounded Thermocouple inputs, connect the Internal Ground Connection shown in [Figure 9](#) to the same earth ground as used by the thermocouple.

As noted above, the Loop Power wiring shield should only be connected to earth ground at the power supply end.

3.5.5. Supply Voltage Limiting Requirements

For Protection of Explosion-proof/ Flameproof and Non Incendive/ Non Sparking the power supply has to include a voltage limiting device. Voltage must be limited such that it does not exceed 42 V DC. Consult the process design system documentation for specifics.

3.5.6. Process Sealing

The STT 750 SmartLine Temperature Transmitter is CSA-certified as a Dual Seal device in accordance with ANSI/ISA-12.27.01-2003, "Requirements for Process Sealing Between Electrical Systems and Flammable, or Combustible Process Fluids."

3.5.7. Explosion-Proof Conduit Seal



When installed as explosion proof in a Division 1 Hazardous Location, keep covers tight while the Transmitter is energized. Disconnect power to the Transmitter in the non-hazardous area prior to removing end caps for service.

When installed as non-incendive equipment in a Division 2 hazardous location, disconnect power to the Transmitter in the non-hazardous area, or determine that the location is non-hazardous before disconnecting or connecting the Transmitter wires.

Transmitters installed as explosion proof in Class I, Division 1, Group A Hazardous (classified) locations in accordance with ANSI/NFPA 70, the US National Electrical Code, Canadian Electric Code CCSAC22.1, with 1/2 inch conduit do not require an explosion-proof seal for installation. If 3/4 inch conduit is used, a LISTED explosion proof seal to be installed in the conduit, within 18 inches (457.2 mm) of the transmitter.

Crouse-Hinds type EYS/EYD or EYSX/EYDX are examples of LISTED explosion proof seals that meet this requirement. Transmitters installed as explosion proof in Class I, Division 1, Group B, C or D hazardous (classified) locations do not require that explosion proof seal be installed in the conduit.

3.5.8. Input Sensor Wiring

Connect the input sensors as shown in Figures below:

Figure 10 – STT 750 Thermocouple, RTD, mV, ohm and Volt Connections

- Ohm and Resistance temperature detector (RTD) measurements use the 3 or 4 wire approach.

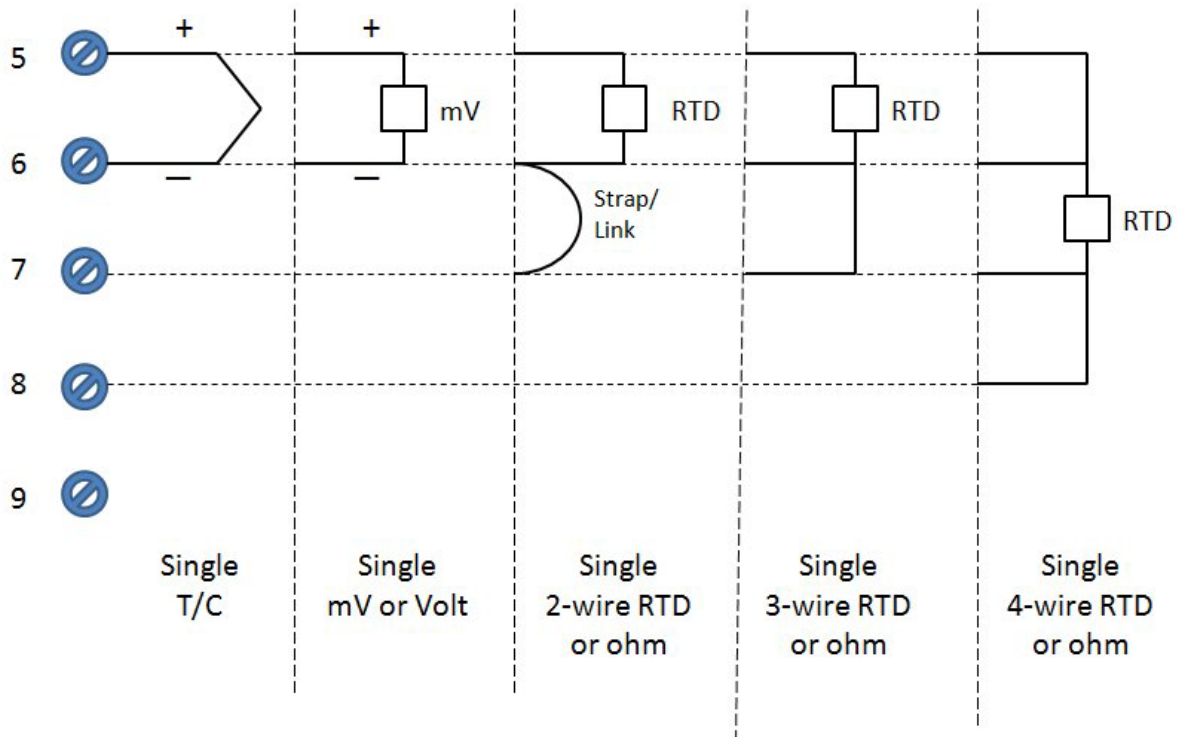

Figure 10 – STT 750 Thermocouple, RTD, mV, ohm and Volt Connections

3.6. Startup

3.6.1. Overview

This section identifies typical start up tasks associated with several generic temperature measurement applications. It also includes the procedure for running an optional analog output check.

3.6.2. Startup Tasks

After completing the installation and configuration tasks for a Transmitter, you are ready to start up the process loop. Startup usually includes:

- Setting initial resistance (RTD sensor types only)
- Reading inputs and outputs
- Applying process inputs to the transmitter.

The actual steps in a startup procedure vary based on the type of Transmitter and the measurement application. In general, the procedures in this section are based on using Honeywell MC Toolkit, with a HART variant, to check the Transmitter input and output under static process conditions, and make adjustments as required initiating full operation with the running process.

Note: Checks can be made using the optional three-button assembly, if your Transmitter is so equipped. Operation with the three-button assembly is discussed in the “Operation” section of this manual.

3.6.3. Output Check Procedures

The Output Check comprises the following procedures:

- The Loop Test procedure checks for continuity and the condition of components in the output current loop.
- The Trim DAC Current procedure calibrates the output of the Digital-to-Analog converter for minimum (0%) and maximum (100%) values of 4 mA and 20 mA, respectively. This procedure is used for Transmitters operating online in analog mode to ensure proper operation with associated circuit components (for example, wiring, power supply, control equipment). Precision test equipment (an ammeter or a voltmeter in parallel with precision resistor) is required for the Trim DAC Current procedure.
- The Apply Values procedure uses actual Process Variable (PV) input levels for calibrating the range of a Transmitter. The PV is carefully adjusted to stable minimum and maximum levels, and the Lower Range Limit Value (LRV) and Upper Range Limit Value (URV) are then set by commands from the MC Toolkit.



The Transmitter does not measure the given PV input or update the PV output while it operates in the Output mode.

3.6.4. Constant Current Source Mode Procedure

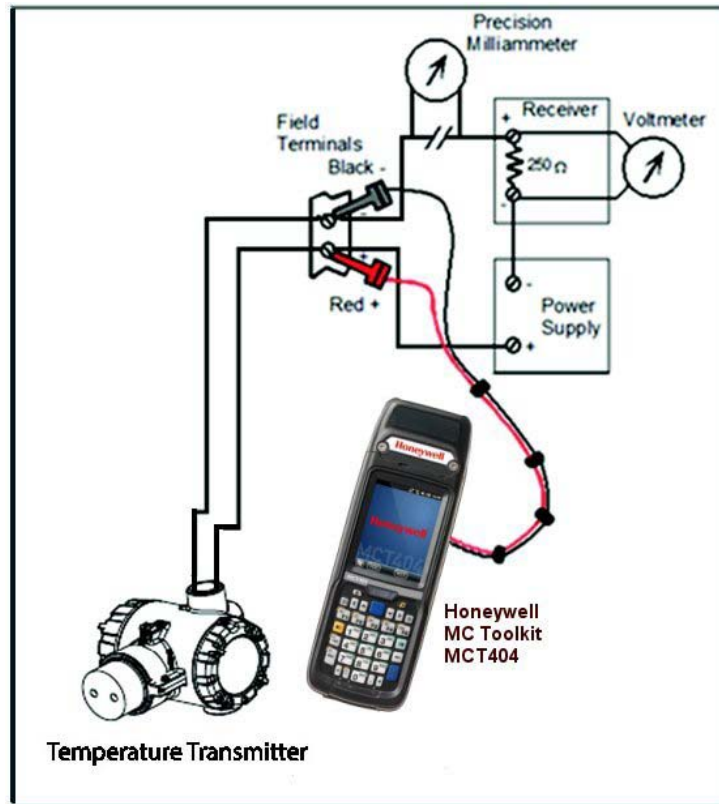

Figure 11 – Current Loop Test Connections

1. Refer to [Figure 11](#) for test connections. Verify the integrity of electrical components in the output current loop.
2. Establish communication with the Transmitter. For these procedures, the values of components in the current loop are not critical if they support reliable communication between the Transmitter and the Toolkit.
3. On the Toolkit, display the **Output Calibration** box.
4. In the Output Calibration box, select the **Loop Test** button; the **LOOP TEST** box will be displayed.
5. Select the desired constant-level Output: 0 %, 100 %, or Other (any between 0 % - 100 %).
6. Select the Set button. A box will be displayed asking **Are you sure you want to place the transmitter in output mode?**



With the Transmitter in Analog mode, you can observe the output on an externally-connected meter or on a local meter.

7. Select the **Yes** button. Observe the output current at the percentage you selected in Step 5.
8. To view the monitor display, navigate back from the **LOOP TEST** display, and select the **MONITOR** display. A **Confirm** popup will be displayed.
9. Select **Yes** to continue. This concludes the Startup procedure.

4. Operation

4.1. Overview

This section provides the information and processes involved for HART operation using the 3-button option.

4.2. Three-Button Operation

The STT 750 optional three-button interface is located under the nameplate and provides a user interface and operation capability without opening the transmitter.

[Figure 12](#) shows the location of the three-button option and the labels for each button.

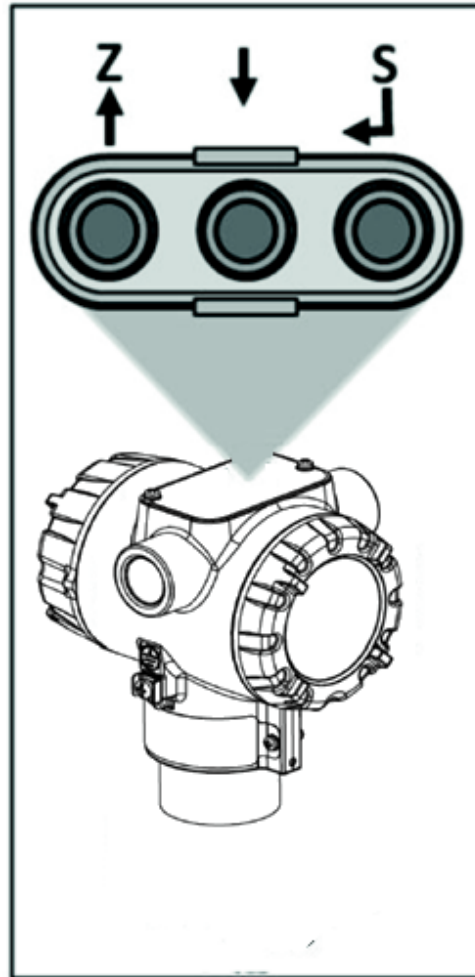

Figure 12 - Three-Button Option

Table 5 – Three-Button Option Functions

Physical Button	Display	Action
Left ↑	Increment Previous Menu Item	Scroll to previous menu item in an active list. Scroll through alphanumeric list to desired character (ex. for entering Tag names or numeric values)
Center ↓	Decrement Next Menu Item	Scroll to next menu item in an active list. Scroll through alphanumeric list to desired character (ex. for entering Tag names or numeric values)
Right ↵	Select displayed menu item for activation or editing	Call up the menu. Select an item for data entry. Confirm a data entry operation Activate the service associated with a selected menu item.

4.2.1. Menu Navigation

The user must press ↵ button to call up the menu. To exit the menu and return to the PV display screen, select **Exit menu**.

Use the ↑ and ↓ buttons to scroll through or wrap around the list of menu items. Press the ↵ button to select an item for data entry or activation. When an item is selected for data entry or activation, the cursor will appear on the lower line of the LCD (Display) to allow editing of the value.

No action is taken against a menu item until the ↵ button is pressed.

After a user presses the ↵ button to begin a data entry operation, another button must be pressed within 10 seconds or data entry will time out and the original value of the parameter will be preserved.

If no button presses occur within 60 seconds, menu access will time out and the transmitter will exit the menu and return to the PV display.

4.2.2. Data Entry

Data entry is performed from left to right. Select a character / digit by pressing ↑ or ↓ buttons, and then press ↵ to advance to the next character position to the right. Select the << character to terminate the entry or if the final character is already a space character, just press ↵ again.

All numeric entries are clamped at the low or high limit if needed. You can determine the low and high limit for a parameter by selecting either the **H** or **L** character while the cursor is positioned over the left-most digit and press ↵ button. The Display will show the selected limit.

Table 6 – Three-Button Data Entry

Screen Symbol	Numeric data entry	Text entry
H	Display the high limit for this parameter. This symbol only appears in the left-most position of the data entry field.	Not Available
L	Display the low limit for this parameter. This symbol only appears in the left-most position of the data entry field.	Not Available
<<	Terminate the numeric entry	Terminate the text entry
0 thru 9, Minus, Decimal	These characters are used to enter numeric values. The minus sign only appears in the left-most digit.	These characters can be used to create custom tags and unit labels
A thru Z, 0 thru 9 special symbols	Not Available	These characters can be used to create custom tags and unit labels

4.2.3. Editing a Numeric Value

Editing a Numeric Value

Editing of a numeric value is a digit-by-digit process, starting with the left-most digit.

1. Press \leftarrow to begin the edit process.
2. The Display will show the current value of the item on the lower line, left justified.
3. Press the \uparrow or \downarrow buttons to select the desired digit, and then press \leftarrow to advance to the next digit to the right.
4. After the last digit has been entered, press \leftarrow one more time to write the new value to the transmitter.

4.2.4. Selecting a new setting from a list of choices

Use the procedure described below to select a new setting for parameters that present a list of choices (e.g., Screen PV, Screen Units, etc.).

1. Press \leftarrow to begin the edit process.
 - a. The Display will show the current setting of the item on the lower line, left justified.
2. Press the \uparrow or \downarrow buttons to scroll through the list of choices.
3. Press \leftarrow to make your selection. The new selection will be stored in the transmitter and will be displayed on the lower line, right justified.

4.2.5. The Display Menu

Table 7 – The Display Menus

'#' in "Screen #" indicates the screen numbers 1, 2, 3, 4, 5, 6, 7, 8

LCD Contrast	»»»»»	Adjust the LCD contrast level. Range from » (1) to »»»»»»»»» (9) Default: »»»»»»» (7)	Press \leftarrow to enter menu selection \uparrow and \downarrow to select entry. \leftarrow to enter
Rotation Time			
Screen Rotate	Enabled Disabled	Select to enable or disable the automatic rotation of Screens	
Select Screen	1 through 8	Select Screen to configure.	
Screen #	Enabled/Disabled	Select to enable or disable the screen for display and configuration	
Screen # PV	Sensor Loop PV CJ Temperature Sensor Resistance Loop Output Percent Output	Select the Process Variable (PV) that will be shown on the screen. Sensor Resistance is only available for RTDs and will read 0 for thermocouples	
Screen # Decimal	None	Select the PV decimal resolution to be shown on selected screen from list.	
	X.X		
	X.XX		
	X.XXX		
Screen # Units (Writable only for TC/RTD sensor types only)	°C, °F, °R, K	Choose appropriate engineering units from list	
Range/Cal Units (Visible for TC and RTD sensor type only)	°C, °F, °R, K	Select the ranging and calibration temperature units	
Sensor Type	mV, TC, RTD, Ohm	Select Sensor Type	
Sensor ID	Sensor Identifier	Select Sensor ID for selected Sensor Type.	
RTD Type (Visible for RTD sensor type only)	2-Wire, 3-Wire, 4-Wire	Select the RTD Type according to the number of lead wires	
RTD Lead Wire (Visible for RTD sensor type and 2-wire RTD type only)	####.##	Resistance value of the sensor lead wire. (only if RTD)	
Sensor Bias	####.##	Bias on the measured value	
Sensor Cal Lo Pt	####.##	Calibration low point for Sensor	

Sensor Cal Hi Pt	####.##	Calibration high point for Sensor	Press ↵ to enter menu selection
Do Sensor Cal Lo	Confirm	Executing this selection corrects the Cal Low Point based on the input measurement	↑ and ↓ to select entry. ↵ to enter
Do Sensor Cal Hi	Confirm	Executing this selection corrects the Cal High Point based on the input measurement	
Sensor LRV	####.##	Lower Range Value representing 0% output	Read Only Parameter
Sensor URV	####.##	Upper Range Value representing 100% output	Read Only Parameter
Reset Sensor Cal	Confirm	Executing this selection Resets the LRV, and URV Corrects back to Factory values	Press ↵ to enter menu selection ↑ and ↓ to select entry. ↵ to enter
Break Detect	Enable, Disable	Enable or disable detection of Input wire break	
Latching	Enabled, Disabled	When enabled, causes all critical sensor input failures to latch to the Critical Fault state. The fault may only be cleared by device reset. When disabled, the critical sensor input failure will be cleared if the input recovers.	
CJ Type	Internal, Fixed	Determines the source of the Cold Junction compensation for thermocouple Sensor types.	
Fixed CJ Value (Visible for TC input only)	####.##	When CJ Type is Fixed, specifies the Cold Junction temperature value for thermocouple Sensor types. Degrees Celsius. Fixed CJ temperatures below -50 degrees have no effect on measured values.	
LRV URV	#. ## #. ##	The limits are: the Lower Range Limit (LRL) and the Upper Range Limit (URL) of the selected Sensor ID	
Set LRV	Set Lower Range Value	ATTENTION: Executing this service will set the Lower Range Value (LRV) equal to the input measurement	
Set URV	Set Upper Range Value	ATTENTION: Executing this service will set the Upper Range Value (URV) equal to the input measurement	
Damping	#. ##	Selection applies digital filtering to suppress noise effects on the PV. The limits for this value are 0.0 to 32.0 seconds	
NAMUR Output	Enabled Disabled	Disabling sets the loop output and burnout levels to the Honeywell levels	

DAC Zero Trim Note: Loop must be removed from Automatic Control	DAC Zero Trim	This selection allows the loop zero output 4mA value to be trimmed. Note: You must connect a current meter to the transmitter to monitor the loop output.	
DAC Span Trim Note: Loop must be removed from Automatic Control	DAC Span Trim	This selection allows the loop span output 20mA value to be trimmed. Note: You must connect a current meter to the transmitter to monitor the loop output.	Press \leftarrow to enter menu selection \uparrow and \downarrow to select digit. \leftarrow to enter
Loop Test Note: Loop must be removed from Automatic Control	Loop Test 12.000	This selection allows the user to force the DAC output to any value between 3.8 and 20.8 mA. Note: This selection will put the DAC into Fixed Output Mode, as indicated by the flashing output value. Navigation away from this menu item will return the loop to Normal (Automatic) Mode.	
Tag ID	□□□□□□□□	Enter Tag ID name up to 8 characters long. □ = any Alphanumeric value	
HART Device ID	Unique for each device	Unique ID for device	Read Only Parameter
HART PV Units	Units of transmitted PV	Units for the Primary Variable (Writable - for TC/RTD Sensor Type, Read only - mV and Ohm Sensor Type)	
HART SV Units	Units of transmitted SV	Units for the Secondary Variable	Press \leftarrow to enter menu selection \uparrow and \downarrow to select entry. \leftarrow to enter
Install Date	DD MM YYYY	This selection allows the user to enter the date a transmitter is installed. The Install Date is entered in sequence of Day, Month, and Year, followed by the new date and the prompt Write Date to confirm the entry. CAUTION: The Install Date can only be written once in the life of the Transmitter. You cannot erase or overwrite the Install Date once it has been written.	
Firmware	Display Electronics Sensor	Menu item shows the current Firmware versions of the Display, Electronics Module and the Sensor Module	Read Only Parameter
Protocol	HART	Menu item shows the communications protocol	Read Only Parameter
Model Key		Identifies the type and range of the transmitter	Read Only Parameter
<Exit Menu>			

4.3. Three Button Operation with no Display Installed

When there is no Display installed, the buttons can be used to perform a Zero or Span adjustment of the Transmitter. Caution should be taken to insure these adjustments are only made when the correct input values are applied.

4.3.1. Zero Adjustment

This adjustment is the same as performing a Set LRV using the Display.

1. Connect a current meter or voltmeter as shown in [Figure 11](#) to monitor the PV output of the Transmitter.
2. Using an accurate input source, apply a signal equivalent to the Transmitter LRV.
3. Press the Down (↓) and Zero (↑) buttons together to set the Zero.
4. Verify that the output is now 4 mA.

4.3.2. Span Adjustment

This adjustment is the same as performing a Set URV using the Display.

1. Connect a current meter or voltmeter as shown in [Figure 11](#) to monitor the PV output of the Transmitter.
2. Using an accurate input source, apply a signal equivalent to the desired Upper Range Value of the transmitter.
3. Press the **Down** (↓) and **Span** (↵) buttons together to set the span.
4. Verify that the PV output is now 20 mA.



You can also use the [MCT 202 and MCT404 Toolkit](#) to make any adjustments to an STT 750 SmartLine Temperature Transmitter.

4.4. Changing the Default Failsafe Direction

For HART the transmitters are shipped with a default failsafe direction of upscale. This means that the Transmitter output will set the current output to upscale failsafe (maximum output) upon detection of a critical status. The failsafe direction can be changed from upscale to downscale (minimum output) by moving the top jumper located in the Electronic module.

The Transmitter electronics module interprets either signal as *not-a-number* and initiates its own configured failsafe action for the control system.

4.4.1. Procedure to Establish Failsafe Operation



The failsafe direction display accessible via the Toolkit shows only the state of the jumper as it correlates to analog Transmitter operation.



The integrated circuits in the Transmitter PWA are vulnerable to damage by stray static discharges when removed from the Electronics Housing. Minimize the possibility of static discharge damage when handling the PWA as follows:

Do not touch terminals, connectors, component leads, or circuits when handling the PWA.

When removing or installing the PWA, handle it by its edges or bracket section only. If you need to touch the PWA circuits, be sure you are grounded by staying in contact with a grounded surface or by wearing a grounded wrist strap.

When the PWA is removed from the Transmitter, put it in an electrically conductive bag, or wrap it in aluminum foil to protect it.

The following procedure outlines the steps for positioning the write protect and failsafe jumpers on the electronics module. See [Figure 13](#) for the locations of the failsafe and write protect jumpers.

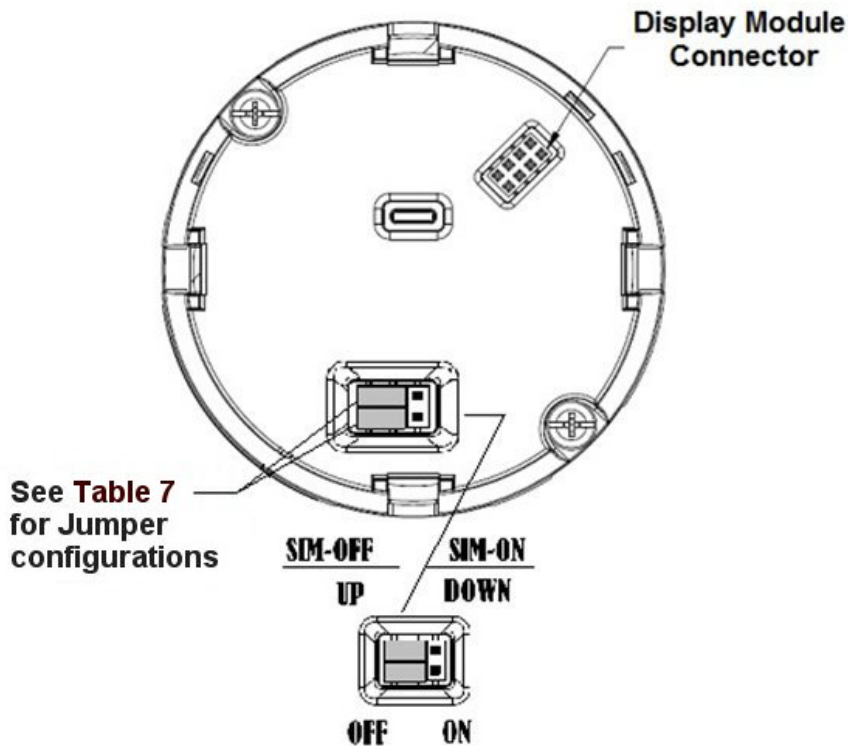

Figure 13 – Locating the Failsafe and Write Protect Jumpers

Table 8 – HART Failsafe and Write Protect Jumpers

Jumper Arrangements	Description
	Failsafe = UP (High) Write Protect = OFF (Not Protected)
	Failsafe = DOWN (Low) Write Protect = OFF (Not Protected)
	Failsafe = UP (High) Write Protect = ON (Protected)
	Failsafe = DOWN (Low) Write Protect = On (Protected)

1. Turn OFF Transmitter power (Power removal is only required in accordance with area safety approvals. Power removal is only required in Class 1 Div 1 Explosion proof and Class 1 Div 2 environments).
2. Loosen the end cap lock, and unscrew the end cap from the electronics side of the Transmitter housing.
3. If equipped with a Display module, carefully depress the two tabs on the sides of the Display Module, and pull it off.

4. If necessary, unplug the interface connector from the Communication module. Do not discard the connector.
5. Set the Failsafe Jumper (top jumper) to the desired position (UP or DOWN). See [Table 7](#) and [Figure 13](#) for jumper positioning.
6. If applicable, re-install the Display module as follows:
 - Orient the display as desired.
 - Install the Interface Connector in the Display module such that it will mate with the socket for the display in the Communication module.
 - Carefully line up the display, and snap it into place. Verify that the two tabs on the sides of the display latch.

NOTE: Installing a Display Module into a powered transmitter may cause a temporary upset to the loop output value.



Orient the Display for proper viewing through the end cap window. You can rotate the meter mounting orientation in 90° increments.

7. Restore transmitter power if removed.

4.5. Monitoring the Display

This section describes the information shown on the operator screens of the Display.

4.5.1. Display

[Figure 14](#) illustrates the Display format with Process Variable (PV).

- The PV value is user-configurable. This field has 7 characters. The maximum allowable numeric value is 9999999 or -999999. If fractional decimals are configured, the fractional positions will be dropped, as required. If the PV value exceeds the above limits, it is divided by 1000 and “K” is appended to the result, allowing a maximum value with multiplier of 999999K or -99999K.
- Process Variable Tag is user-configurable from a HART Host. This field has 14 characters.
- Engineering Units. This field is user-configurable when measuring temperature.



Figure 14 – Display with Process Variable Format

5. Maintenance

5.1. Overview

This section provides information about preventive maintenance and replacing damaged parts. The topics covered in this section are:

- Replacement of damaged parts such as the Electronics Modules.

5.2. Preventive Maintenance Practices and Schedules

The STT 750 SmartLine Transmitter does not require any specific maintenance at regularly scheduled intervals.

Maintenance of the STT 750 is limited to ensuring that connections, seals and mounting are tight and secure. There are no moving parts or adjustments and hence no reason to open the field housing except to inspect for corrosion or conductive dust entry which could later affect reliable operation. The transmitter modules themselves should never be opened.

5.3. Replacing the Communication Module

The Communication module includes a connector to the optional Display module. This section includes the procedure to replace the Communication module.



The transmitter does not have to be removed from service to replace the Comm Module



Please take appropriate steps to avoid ESD damage when handling the Communication and Display Module assemblies

Refer to [Figure 15](#) for parts locations.

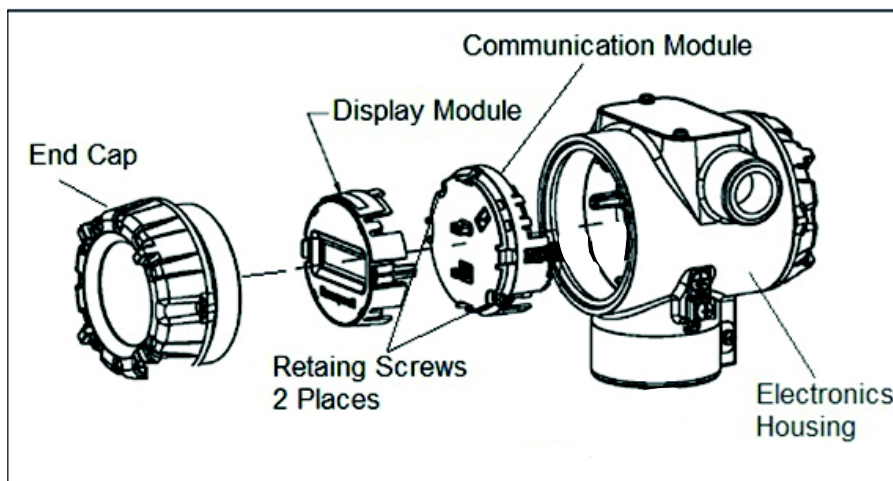

Figure 15 – PWA Replacement

1. Turn OFF Transmitter power (Power removal is only required in accordance with area safety approvals. Power removal is only required in Class 1 Div 1 Explosionproof and Class 1 Div 2 environments).
 - When removing the Communications Module with power applied, the loop will go to 0V. Likewise, installing a Communications Module into a transmitter with power applied will cause the loop output value to go to 12 ma for several seconds then the loop output value will go to the configured value based on the PV input.
 - Installing a Display Module into a powered transmitter may cause a temporary upset to the loop output value.
2. Loosen the end cap lock, and unscrew the end cap from the electronics side of the Transmitter housing.
3. If equipped with a Display module, carefully depress the two tabs on the sides of the Display Module, and pull it off.
4. If necessary, unplug the Display interface connector from the Communication module. **Do not discard the connector.**
5. Loosen the two retaining screws, and carefully pull the Communication module from the Electronics compartment.
6. Carefully, insert the Communication module into the Electronics compartment.
7. Tighten the two Communication module retaining screws.
8. Refer to the SmartLine User's Manual to change the Failsafe and Write Protect Jumper configuration settings.
9. If applicable, re-install the Display module as follows:
 - a) Orient the display as desired.
 - b) Install the Interface Connector in the Display module such that it will mate with the socket for the display in the Communication module.
 - c) Carefully line up the display, and snap it into place. Verify that the two tabs on the sides of the display latch.



Orient the Display for proper viewing through the end cap window. You can rotate the meter mounting orientation in 90° increments.

10. Apply Parker Super O-ring Lubricant or equivalent to the end cap O-ring before installing the end cap. Reinstall the End Cap and tighten the End Cap locking screw.
11. Installing Optional External Configuration Button Assembly.
 - a) Loosen (Do Not Remove) both top nameplate screws and pivot nameplate 90°.
 - b) Align the protrusion on the button assembly with the matching opening in the housing and snap the button assembly into the housing.
 - c) Rotate the nameplate back to the original position, and tighten the nameplate screws.

(Steps 13 - 16 required for Field Upgrades Only)

12. Loosen the End Cap locking screw and unscrew the End Cap from the Field Wiring side of the transmitter housing.
13. Select the proper Communication/External Configuration upgrade kit label from the label strip provided and adhere to the inside of the Field Wiring compartment End Cap.
14. Apply Parker Super O-ring Lubricant or equivalent to the end cap o-ring before installing the end cap. Reinstall the End Cap and tighten the end cap locking screw
15. Install external upgrade label (i.e. DEVICE MODIFIED.....) provided on outside of housing as shown in [Figure 15](#).
16. Restore power if removed.
17. Check the settings of the Transmitter Setup and Display Setup parameters to make sure that the transmitter is configured correctly for your application. Refer to the STT 750 HART manual (34-TT-25-15) for details on HART transmitters.
18. If applicable, verify External Button Configuration operation.

Installation is complete.

This page has been intentionally left blank

6. Calibration

6.1. Recommendations for Transmitter Calibration

The STT 750 SmartLine Temperature Transmitter does not require periodic calibration to maintain accuracy. Typically, calibration of a process-connected Transmitter will degrade, rather than augment the capability of a smart Transmitter. For this reason, it is recommended that a Transmitter be removed from service before calibration. Moreover, calibration must be accomplished in a controlled, laboratory-type environment, using certified precision equipment.

6.2. Calibration Procedures

For a Transmitter operating in analog mode, you must calibrate its output signal measurement range using any compatible hand-held communicator or a local display.

One calibration option is to use the Honeywell MC Toolkit (MCT). Refer to the *MC Toolkit (MCT404) User Manual*, Document # 34-ST-25-50.

Calibration information and procedures for a Transmitter operating in the HART mode are provided in the *STT 750 Series HART Option User's Manual*, document number 34-TT-25-15, Section on "Calibration."

This page is left blank intentionally

7. Troubleshooting

7.1. Overview

Troubleshooting involves responding to error messages, primarily displayed by the MC Toolkit. Error messages that may occur on the Transmitter’s local display are fairly self-explanatory and intuitive. However, this section covers the diagnostic messages that indicate critical conditions. Other than the critical conditions, additional detail is not provided. If you require assistance, contact your distributor or Honeywell Technical Support. All other messages are covered by the MC Toolkit Users’ Manual.

7.2. Critical Diagnostics Screens

When a Critical Diagnostic is present in the Transmitter, the Display will display the message CRITICAL FAULT on the top line of the LCD and the appropriate diagnostic text on the lower line.

7.2.1. Fault Conditions and Recommended Corrective Actions

Table 9 – Fault Conditions and Recommended Corrective Actions.

Condition	Analysis	Recommended Corrective Action
Electronics Module Fault. A critical failure has been detected on the HART Electronics Module.	Use a HART communicator to read the detailed status information from the transmitter. Refer to the appropriate communicator manual for more information about the possible failure causes.	Cycle power to the transmitter. If the problem continues to occur replace the Electronics Module.
Temperature Sensor Module Fault. A critical failure has been detected on the Temperature Sensor Module.	Use a HART communicator to read the detailed status information from the transmitter. Refer to the appropriate communicator manual for more information about the possible failure causes.	If the diagnostic status indicates an input problem (burnout, out of range, etc.), correct the root error and then cycle power to the transmitter. If the problem continues to occur replace the Temperature Sensor Module.
Temperature Sensor Comm Fault. Cannot communicate with the Temperature Sensor Module.	Use a HART communicator to read the detailed status information from the transmitter. Refer to the appropriate communicator manual for more information about the possible failure causes.	Cycle power to the transmitter. If the problem continues to occur replace the Temperature Sensor Module.

This page is left blank intentionally

8. Parts List

8.1. Overview

Individually saleable parts for the various Transmitter models are listed in this section. Some parts are illustrated for identification. Parts are identified and listed in the corresponding tables as follows:

- Individually saleable parts are indicated in each figure by key number callout.
- Parts that are supplied in kits are indicated in each illustration by key number callout with the letter K prefix.

Table 9 is a summarized list of recommended spare parts.

Table 10 – Summary List of Recommended Spare Parts

Part Number	Description	Figure No.	Key No.	1-10 Units	10-100 Units
Electronics Housing Assembly					
50086423-501	HART Electronics Module Without REED Sensor PWA	Figure 18	5	1	1-2
50086423-502	HART Electronics Module With REED Sensor PWA				
50049911-502	Display Module	Figure 17	4	1	1-2
50086421-501	HART Temperature/Terminal Block Assy Without Lightning Protection, Single Input	Figure 18	3	1	1
50086421-503	HART Temperature/Terminal Block Assy With Lightning Protection, Single Input				

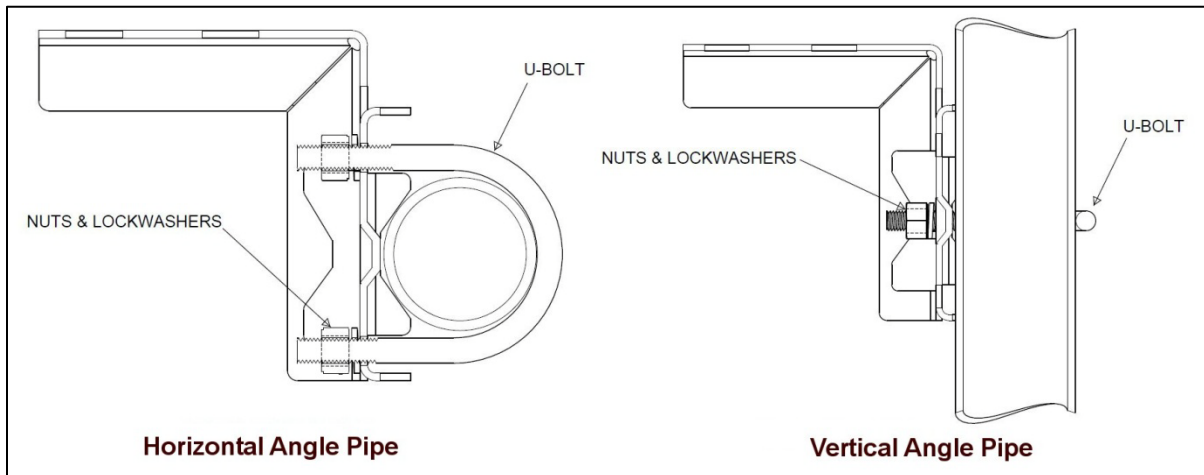
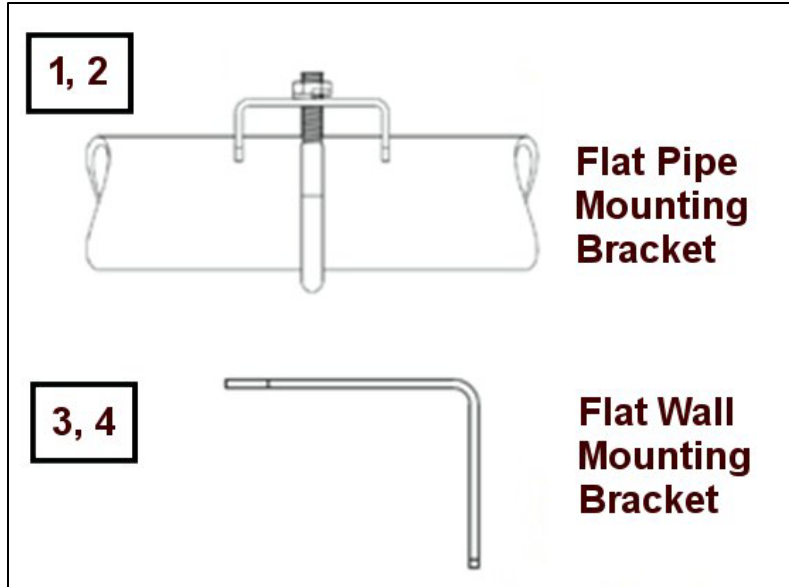

Figure 16 – Pipe and Wall Bracket Parts

Flat Pipe Mounting Bracket	Carbon Steel
Flat Pipe Mounting Bracket	316 SS
Marine Approved Mounting Bracket	316 SS
Wall Mounting Bracket	Carbon Steel
Wall Mounting Bracket	316 SS
Angle Pipe Mounting Bracket	Carbon Steel
Angle Pipe Mounting Bracket	316 SS

Table 11 – Pipe and Wall Bracket Parts
(Refer to [Figure 16](#))

Key No.	Part Number	Description	Qty Per Unit
1	50090524-501	Carbon Steel Flat Pipe Bracket Mounting kit for all models	1
2	50090524-503	316 Stainless Steel Flat Pipe Bracket Mounting kit for all models	1
3	50092363-501	Carbon Steel Wall Bracket Mounting kit for all models	1
4	50092363-503	316 Stainless Steel Wall Bracket Mounting kit for all models	1
5	30752770-007	Carbon Steel Angle Pipe Bracket Mounting kit for all models	1
6	30752770-407	316 Stainless Steel Angle Pipe Bracket Mounting kit for all models	1

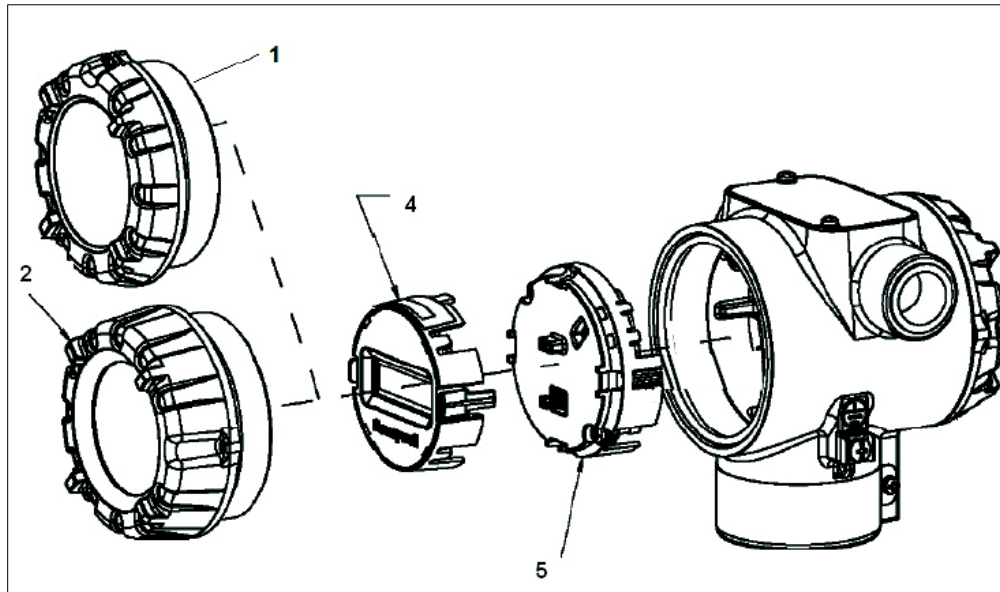

Figure 17 – Electronic Housing, Display End

Table 12 – Transmitter Major Assemblies
(Refer to [Figure 17](#), [Figure 18](#))

Key No.	Part Number	Description	Quantity Per Unit
1	50049858-501	End Cap (Aluminum)	1
	50049858-521	End Cap (Stainless Steel)	
2	50049832-501	End Cap, Display (Aluminum)	1
	50049832-521	End Cap, Display (Stainless Steel)	
3	50086421-501	HART Temperature/Terminal Block Assy Without Lightning Protection, Single Input	1
	50086421-503	HART Temperature/Terminal Block Assy With Lightning Protection, Single Input	

4	50049911-502	Display for Temperature	1
5	50086423—501	HART Electronics Module Assembly (PWA) without Reed sensor	1
	50086423--502	HART Electronics Module Assembly (PWA) with Reed sensor	
6	50049915-501	External Zero, Span & Config Buttons (HART)	1
K1	30757503-005	Electronics housing seals kit (includes O-rings)	

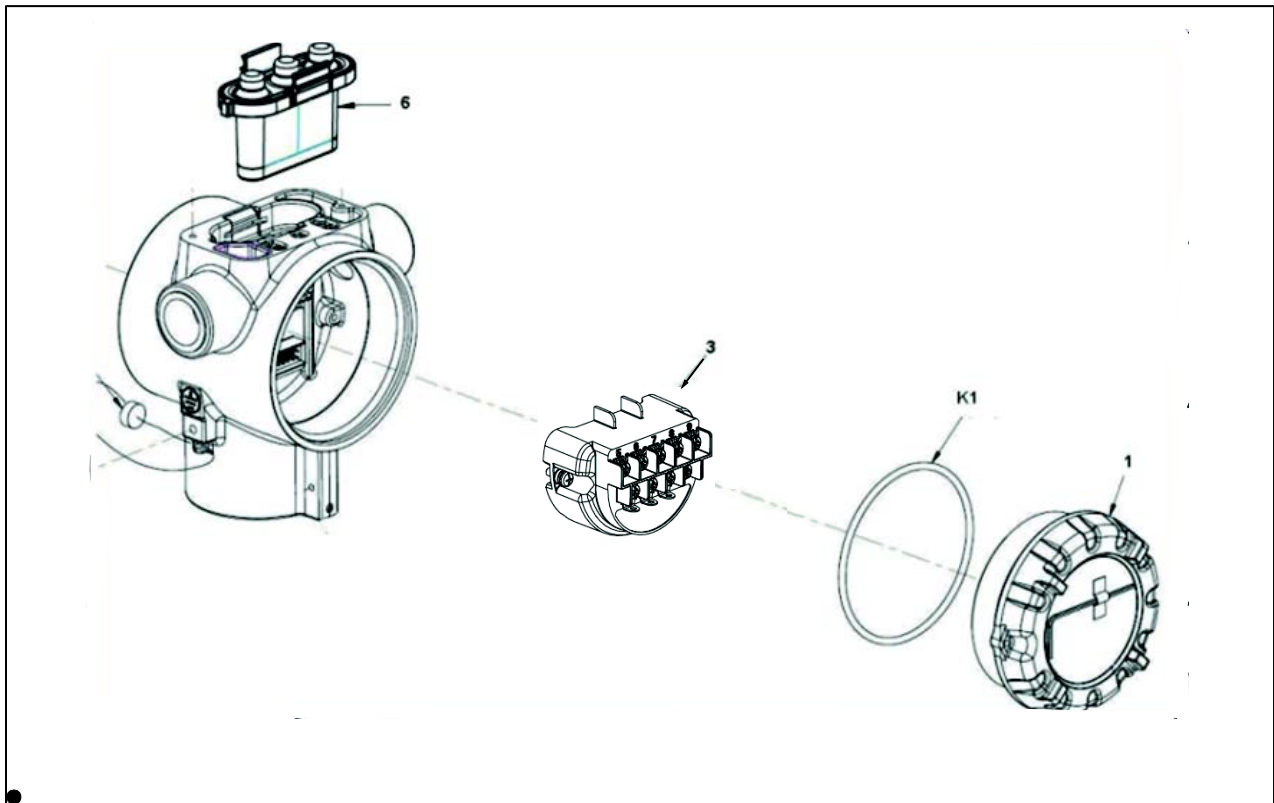

Figure 18 – Electronic Housing, Terminal Block End

Appendix A. PRODUCT CERTIFICATIONS

A1. Safety Instrumented Systems (SIS) Installations

For Safety Certified Installations, please refer to STT 850 & STT 750 Safety Manual 34-TT-25-05 for installation procedure and system requirements.

A2. European Directive Information (CE Mark)



50094560 Revision: E

EC DECLARATION OF CONFORMITY

We,

Honeywell International Inc.
Honeywell Field Solutions
512 Virginia Drive
Fort Washington, PA 19034 USA

declare under our sole responsibility that the following products,

STT 850 – Smart Series Temperature Transmitter
STT 750 – Smart Series Temperature Transmitter

to which this declaration relates, is in conformity with the provisions of the European Community Directives, including the latest amendments, as shown in the attached schedule.

Assumption of conformity is based on the application of the harmonized standards and when applicable or required, a European Community notified body certification, as shown in the attached schedule.

The authorized signatory to this declaration, on behalf of the manufacturer, and the Responsible Person is identified below.

Owen J. Murphy
Product Safety & Approvals Engineering

Issue Date: 24 July 2015

SCHEDULE

50094560 Revision: E

EMC Directive (2004/108/EC)

- IEC 61326-1:2005 Electrical Equipment for Measurement, Control and Laboratory Use – EMC Requirements.
- IEC 61326-3-1:2008 Electrical Equipment for Measurement, Control and Laboratory Use- Part 3-1: Immunity Requirements for safety related systems and equipment intended to perform safety-related functions.

Overview of EMC Testing
 Equipment Tested (EUT): ST 850 TRANSMITTER

Summary of Tests Performed:

PORT	TEST	STANDARD	CRITERIA (IEC 61326-1)	CRITERIA (IEC 61326-3-1)	RESULTS
Enclosure	Radiated Emission	CISPR 11	Group1, Class A 30 – 230 MHz: 40 dB 230 – 1000 MHz: 47 dB	Group1, Class A 30 – 230 MHz: 40 dB 230 – 1000 MHz: 47 dB	PASS
	ESD Immunity	IEC61000-4-2	+/- 4KV Contact +/- 8KV Air	+/- 6KV Contact +/- 8KV Air	PASS
	EM Field- RF Radiated Susceptibility	IEC61000-4-3	10 V/m- 80 MHz to 1GHz 3 V/m - 1.4 GHz to 2.0 GHz 1 V/m- 2.0 GHz to 2.7 GHz	20 V/m- 80MHz to 1GHz 10 V/m - 1.4GHz to 2.0 GHz 3 V/m- 2.0GHz to 2.7GHz	PASS PASS PASS
	50Hz/60Hz Magnetic Field Immunity	IEC 6100-4-8	30 A/m	30 A/m	N/A 1
DC Power	EFT(B) Immunity	IEC61000-4-4	+/- 1KV	+/- 2KV	PASS
	Surge Immunity	IEC61000-4-5	+/- 1KV	+/- 2KV	PASS
	RF Conducted Susceptibility	IEC61000-4-6	3V	3 V Except the following: 10 V 3.39 to 3.410MHz 10 V 6.765 to 6.795MHz 10 V 13.553 to 13.567MHz 10 V 26.957 to 27.283MHz 10 V 40.66 to 40.70MHz	PASS

SCHEDULE

50094560 Revision: E

PORT	TEST	STANDARD	CRITERIA (IEC 61326-1)	CRITERIA (IEC 61326-3-1)	RESULTS
I/O Signal/ Control (Including Earth Lines)	EFT(Burst) Immunity	IEC61000-4-4	+/- 1KV	+/- 2KV	2
	Surge Immunity	IEC61000-4-5	+/- 1KV	+/- 2KV	2
	RF Conducted Susceptibility	IEC61000-4-6	3V	3 V Except the following: 10 V 3.39 to 3.410MHz 10 V 6.765 to 6.795MHz 10 V 13.553 to 13.567MHz 10 V 26.957 to 27.283MHz 10 V 40.66 to 40.70MHz	2
AC Power	Voltage Dip	IEC61000-4- 11	0% during 1 Cycle 40% during 10-12 Cycles 70% during 25-30 Cycles		N/A ³
	Short Interruptions	IEC61000-4- 11	0% during 250-300 Cycles		N/A ³
	EFT(Burst) Immunity	IEC61000-4-4	2KV		N/A ³
	Surge Immunity	IEC61000-4-5	1KV/ 2KV		N/A ³
	RF Conducted Susceptibility	IEC61000-4-6	3V		N/A ³

1. There is no magnetic sensitive circuitry.
2. Done as part of the DC Power Testing.
3. Product is DC Powered.

SCHEDULE**50094560 Revision: E****ATEX Directive (94/9/EC)**

EC-Type Examination Certificate No: SIRA 14ATEX0020X

Protection : Flameproof “d” and Intrinsically Safe “ia” CertificateEN 60079-0: 2012 EN 60079-1: 2007 EN 60079-11: 2011
EN 60079-26: 2006 EN 60079-31: 2009

Type Examination Certificate No: SIRA 14ATEX4052X

Protection : Non Sparking “n” Certificate

EN 60079-0: 2012 EN 60079-15: 2010

ATEX Notified Body for EC Type CertificatesSIRA Certification Service
Rake Lane, Eccleston
Chester, CH4 9JN
England**ATEX Notified Body for Quality Assurance**DEKRA Certification B.V. [Notified Body Number: 0344]
Maender 1051
6825 MJ Arnhem
The Netherlands

A3. Hazardous Locations Certifications

MSG CODE	AGENCY	TYPE OF PROTECTION	COMM OPTION	Electrical Parameters	Ambient Temperature
A	FM Approvals™ (USA)	Explosion proof , Certificate: 3051269: Class I, Division 1, Groups A, B, C, D; Dust Ignition Proof: Class II, III, Division 1, Groups E, F, G; T4 Class 1, Zone 1, AEx d IIC T4 Gb Class 2, Zone 21, AEx tb IIIC T 95°C IP66 Db	4-20 mA/ HART	Note 1	-50°C to 85°C
		Intrinsically Safe , Certificate: 3051269: Class I, II, III, Division 1, Groups A, B, C, D, E, F, G; T4 Class I Zone 0, AEx ia IIC T4 Ga	4-20 mA/ HART	Note 2	-50°C to 70°C
		Non-Incendive , Certificate: 3051269: Class I, Division 2, Groups A, B, C, D; T4 Class I Zone 2, AEx nA IIC T4 Gc, AEx nA IIC T4	4-20 mA/ HART	Note 1	-50°C to 85°C
		Standards: FM 3600:2011; ANSI/ ISA 60079-0: 2013 FM 3615:2006; ANSI/ ISA 60079-1 : 2009 FM 3616 : 2011 ; ANSI/ ISA 60079-31 : 2009 FM 3610:2010; ANSI/ ISA 60079-11 : 2013 FM 3810 : 2005 ; FM 3611:2004; ANSI/ ISA 60079-15 : 2012 ; FM 3810 : 2005 ; NEMA 250 : 2003 ; ANSI/ IEC 60529 : 2004			
		Enclosure: Type 4X/ IP66/ IP67	ALL	ALL	ALL
B	CSA-Canada	Explosion proof , Certificate: 2689056: Class I, Division 1, Groups A, B, C, D; Dust Ignition Proof: Class II, III, Division 1, Groups E, F, G; T4 Zone 1 Ex d IIC T4 Gb Ex tb IIIC T 95°C IP 66 Db DIP A21 Class II, III	4-20 mA/ HART	Note 1	-50°C to 85°C
		Intrinsically Safe , Certificate: 2689056: Class I, II, III, Division 1, Groups A, B, C, D, E, F, G; T4 Ex ia IIC T4 Ga	4-20 mA/ HART	Note 2	-50°C to 70°C
		Non-Incendive , Certificate: 2689056: Class I, Division 2, Groups A, B, C, D; T4 Class I Zone 2 Ex nA IIC T4 Gc Ex nA IIC T4 Gc	4-20 mA/ HART	Note 1	-50°C to 85°C
		Enclosure: Type 4X/ IP66/ IP67			
		Enclosure: Type 4X/ IP66/ IP67	ALL	ALL	ALL

		Standards: CSA C22.2 No. 0-10; CSA 22.2 No. 25-1966 (reaffirmed 2009); CSA C22.2 No. 30-M1986 (reaffirmed 2012); CSA C22.2 No. 94-M91; CSA C22.2 No. 142-M1987 (reaffirmed 2009); CSA-C22.2No.157-92 (reaffirmed 2012); C22.2 No. 213-M1987(reaffirmed 2012); C22.2 No. 60529-05 C22.2 No. CSA 60079-0:2011; C22.2 No. 60079-1: 2011; C22.2 No. 60079-11: 2011; C22.2 No. 60079-15: 2012; C22.2 No. 60079-31: 2012; ANSI/ ISA12.12.01-2012; ANSI/ ISA 60079-0 (12.00.01): 2009 ; ANSI/ ISA 60079-1 (12.22.01): 2009 ; ANSI/ ISA 60079-11(12.02.01) : 2012; ANSI/ ISA 60079-26 (12.00.03) : 2011; ANSI/ ISA 60079-15(12.12.02) : 2012 ; ANSI/ ISA 60079-27 (12.02.04) : 2006; ANSI/ ISA 60079-31(12.10.03) : 2009 ; FM Class 3615: Aug 2006; FM Class 3616: Dec 2011; ANSI/ IEC 60529 : Edition 2.1 ANSI/ UL 913: Edition 7; ANSI/ UL 916 : Edition 4 ;			
C	ATEX	Flameproof , Sira 14ATEX2046X: II 2 G Ex d IIC T4 Gb II 2 D Ex tb IIIC T 95°C Db IP 66/ IP67	4-20 mA/ HART	Note 1	-50°C to 85°C
		Intrinsically Safe , Sira 14ATEX2046X: II 1 G Ex ia IIC T4 Ga	4-20 mA/ HART	Note 2	-50°C to 70°C
		Enclosure: IP66/ IP67	ALL	ALL	ALL
		Standards: EN 60079-0: 2012; EN 60079-1 : 2007; EN 60079-31 : 2009 EN 60079-11: 2011; EN 60079-26 : 2006; EN 60529 : 2000 + A1			
		Non Sparking , Sira 14ATEX4052X: II 3 G Ex nA IIC T4 Gc	4-20 mA/ HART	Note 1	-50°C to 85°C
		Enclosure: IP66/ IP67	ALL	ALL	ALL
Standards: EN 60079-0: 2012; EN 60079-15 : 2010; IEC 60529 : 2009 with Corr 3					
D	IECEX	Flameproof , SIR 14.0020X Ex d IIC T4 Gb Ex tb IIIC T 95°C IP 66/ IP67	4-20 mA/ HART	Note 1	-50°C to 85°C
		Intrinsically Safe , SIR 14.0020X Ex ia IIC T4 Ga	4-20 mA/ HART	Note 2	-50°C to 70°C
		Non Sparking , SIR 14.0020X Ex nA IIC T4 Gc	4-20 mA/ HART	Note 1	-50°C to 85°C
		Enclosure: IP66/ IP67	ALL	ALL	ALL
		Standards: IEC 60079-0: 2011, Edition 6; IEC 60079-1 : 2007-04, Edition 6; IEC 60079-11 : 2011, Edition 6; IEC 60079-15 : 2010, Edition 4 IEC 60079-26 : 2006, Edition 2; IEC 60079-31 : 2008, Edition 1 IEC 60529 : 2009 with Corr 3			
		Enclosure: IP66/ IP67	ALL	ALL	ALL

Notes

1. Operating Parameters:

4-20 mA/HART (Loop Terminal)

Voltage= 11 to 42 V

Current= 4-20 mA Normal (3.8 – 23 mA Faults)

2. Intrinsically Safe Entity Parameters

For details see Control Drawing on page 47 of the User's manual

A4. Marking ATEX Directive

General:

The following information is provided as part of the labeling of the transmitter:

- Name and Address of the manufacturer
- Notified Body identification: DEKRA Quality B.V., Arnhem, the Netherlands

- For complete model number, see the Model Selection Guide for the particular model of Temperature Transmitter.
- The serial number of the transmitter is located on the Housing data-plate. The first two digits of the serial number identify the year (02) and the second two digits identify the week of the year (23); for example, 0223xxxxxxx indicates that the product was manufactured in 2002, in the 23rd week.

Apparatus Marked with Multiple Types of Protection

The user must determine the type of protection required for installation the equipment. The user shall then check the box [✓] adjacent to the type of protection used on the equipment certification nameplate. Once a type of protection has been checked on the nameplate, the equipment shall not then be reinstalled using any of the other certification types.

WARNINGS and Cautions:

Intrinsically Safe and Non-Incendive Equipment:

WARNING: SUBSTITUTION OF COMPONENTS MAY IMPAIR SUITABILITY FOR USE IN HAZARDOUS LOCATIONS.

Explosion-Proof/ Flameproof:

WARNING: DO NOT OPEN WHEN AN EXPLOSIVE ATMOSPHERE MAY BE PRESENT

Non-Incendive Equipment:

WARNING: DO NOT OPEN WHEN AN EXPLOSIVE ATMOSPHERE MAYBE PRESENT

All Protective Measures:

WARNING: FOR CONNECTION IN AMBIENTS ABOVE 60°C USE WIRE RATED 105°C

A.5 Conditions of Use” for Ex Equipment”, Hazardous Location Equipment or “Schedule of Limitations”:

Consult the manufacturer for dimensional information on the flameproof joints for repair.

Painted surface of the STT 750 may store electrostatic charge and become a source of ignition in applications with a low relative humidity less than approximately 30% relative humidity where the painted surface is relatively free of surface contamination such as dirt, dust or oil. Cleaning of the painted surface should only be done with a damp cloth.

Intrinsically Safe: Must be installed per drawing 50091227

Division 2: This equipment is suitable for use in a Class I, Division 2, Groups A, B, C, D; T4 or Non-Hazardous Locations Only.

The installer shall provide transient over-voltage protection external to the equipment such that the voltage at the supply terminal of the equipment does not exceed 140% of the voltage rating of the equipment.

The enclosure is manufactured from low copper aluminium alloy. In rare cases, ignition sources due to impact and friction sparks could occur. This shall be considered during Installation, particularly if equipment is installed a Zone 0 location.

If a charge-generating mechanism is present, the exposed metallic part on the enclosure is capable of storing a level of electrostatic that could become incendive for IIC gases. Therefore, the user/ installer shall implement precautions to prevent the buildup of electrostatic charge, e.g. earthing the metallic part. This is particularly important if equipment is installed a Zone 0 location.

A.6 Control Drawing

COPYRIGHT 2015, HONEYWELL INTERNATIONAL INC. NEITHER THIS DOCUMENT NOR THE INFORMATION CONTAINED HEREIN SHALL BE REPRODUCED, USED OR DISCLOSED TO OTHERS WITHOUT THE WRITTEN AUTHORIZATION OF HONEYWELL. USE, DUPLICATION, OR DISCLOSURE OF THIS DOCUMENT IS SUBJECT TO THE RESTRICTIONS SET FORTH IN A WRITTEN AGREEMENT. NOTHING CONTAINED HEREIN SHALL BE CONSTRUED AS CONFERRING BY IMPLICATION, ESTOPPEL, OR OTHERWISE ANY LICENSE TO ANY PATENT, TRADEMARK, COPYRIGHT OR OTHER INTELLECTUAL PROPERTY RIGHT OF HONEYWELL OR ANY THIRD PARTY.				PRE REL					
ISS	REVISION & DATE				APPD				
C	06-9-2015 ECN 2015-1801				OJM				

STT750/850 Series Temperature Transmitter

ANALOG, HART/DE and FF/ PA Communications

1. Intrinsically safe installation shall be in accordance with
 - a. FM (USA): ANSI/NFPA 70, NEC Articles 504 and 505.
 - b. CSA (Canada): Canadian Electrical Code (CEC), part I, section 18.
 - c. ATEX: Requirements of EN 60079-14, 12.3 (See also 5.2.4).
 - d. IECEx: Requirements of IEC 60079-14, 12.3 (See also 5.2.4).
2. ENTITY approved equipment shall be installed in accordance with the manufacturer's Intrinsic Safety Control Drawing.
3. The Intrinsic Safety ENTITY concept allows the interconnection of two ENTITY Approved Intrinsically safe devices with ENTITY parameters not specifically examined in combination as a system when:

$U_o, V_o, \text{ or } V_t \leq U_i \text{ or } V_{max}; I_o, I_{sc}, \text{ or } I_t \leq I_i \text{ or } I_{max}; C_a \text{ or } C_o \geq C_i + C_{cable}, L_a \text{ or } L_o \geq L_i + L_{cable}, P_o \leq P_i.$

Where two separate barrier channels are required, one dual-channel or two single-channel barriers may be used, where in either case, both channels have been Certified for use together with combined entity parameters that meet the above equations.
4. System Entity Parameters:

STT750/ STT850 Transmitter: $V_{max} V_o \text{ or } U_o, I_{max} I_{sc} \text{ or } I_o;$

STT750/ STT850 Transmitter: $C_i + C_{cable} \leq \text{Control Apparatus } C_a,$

STT750/ STT850 Transmitter: $L_i + L_{cable} \leq \text{Control Apparatus } L_a.$
5. When the electrical parameters of the cable are unknown, the following values may be used:

Capacitance: 197pF/m (60 pF/ft)

Inductance: 0.66μH/m (0.020μH/ft).
6. Control equipment that is connected to Associated Equipment must not use or generate more than 250 V.
7. Associated equipment must be FM, CSA ATEX or IECEx (depending on location) listed. Associated equipment may be installed in a Class I, Division 2 or Zone 2 Hazardous (Classified) location if so approved.
8. Non-Galvanically isolated equipment (grounded Zener Barriers) must be connected to a suitable ground electrode per:
 - a. FM (USA): NFPA 70, Article 504 and 505. The resistance of the ground path must be less than 1.0 ohm.
 - b. CSA (Canada): Canadian Electrical Code (CEC), part I, section 10.
 - c. ATEX: Requirements of EN 60079-14, 12.2.4.
 - d. IECEx: Requirements of IEC 60079-14, 12.2.4.
9. Intrinsically Safe DIVISION 1/ Zone 0 WARNING: SUBSTITUTION OF COMPONENTS MAY IMPAIR SUITABILITY FOR USE IN HAZARDOUS LOCATIONS.
10. Division 2/ Zone 2: WARNING: DO NOT OPEN WHEN AN EXPLOSIVE GAS ATMOSPHERE IS PRESENT.
11. NO REVISION OF THIS CONTROL DRAWING IS PERMITTED WITHOUT AUTHORIZATION FROM THE AGENCIES listed.
12. For release approvals see ECO-0110873.

MASTER FILE TYPE: MS WORD	DRAWN	OJM	03/28/14	Honeywell		
	CHECKED			CONTROL DRAWING STT750/STT850 SERIES TEMPERATURE TRANSMITTER DIVISIONS 1 & 2 / ZONE 0 & 2		
	DEV ENG					
	MFG ENG					
	QA ENG					
	TOLERANCE UNLESS NOTED				A/A4	50091227
ANGULAR DIMENSION				SCALE: None	USED ON	SH. 1 OF 5

Revision 1

STT 750 Temperature Transmitter User's Manual

Page 47

INSTRUCTIONS FOR INMETRO

1. Instalação de segurança intrínseca devem estar de acordo com Requisitos de IEC 60079-14, 12.3 (See also 5.2.4).
2. ENTIDADE equipamento aprovado deve ser instalado de acordo com a segurança intrínseca Desenho de Controle do fabricante.
3. O conceito de Segurança Intrínseca ENTIDADE permite a interligação de dois entidade credenciada dispositivos de segurança intrínseca com parâmetros de entidade não examinados especificamente em combinação como um sistema quando:
 - Uo, Voc, or Vt \leq Ui or Vmax; Io, Isc, or It \leq li or Imax; Ca or Co \geq Ci + Ccable, La or Lo \geq Li + Lcable, Po \leq Pi.
 - Quando forem necessários dois canais separados de barreira, um dual-channel ou duas barreiras de canal único pode ser usado, onde em ambos os casos, ambos os canais foram certificados para uso em conjunto com os parâmetros entidade combinada que atendam as equações acima.
4. Parâmetros da Entidade de sistema::
 - Vmax Voc or Uo, Imax Isc or Io;
 - Ci + Ccable \leq Control Apparatus Ca,
 - Li + Lcable \leq Control Apparatus La.
5. Quando os parâmetros eléctricos do cabo não são conhecidos, podem ser utilizados os seguintes valores::
 - Capacidade: 197pF/m (60 pF/ft)
 - Indutância: 0.66µH/m (0.020µH/ft).
6. Os equipamentos de controle que está ligado à Associated Equipment não deve usar ou gerar mais de 250 V.
7. Equipamentos associados devem ser IECEx (dependendo da localização) listados. Equipamentos associados podem ser instalados em uma perigosos (classificados) local Classe I, Divisão 2 ou Zona 2 se for aprovado.
8. O equipamento não Galvanicamente isolado (Barreiras Zener aterradas) deve ser conectado a um eletrodo de aterramento adequado por IECEx: Requisitos de IEC 60079-14, 12.2.4.
9. Intrinsecamente seguro Divisão 1 / Zona 0 AVISO: substituição de componentes pode prejudicar a adequação para uso em locais perigosos.
10. Divisão 2 / Zona 2: AVISO: NÃO aberto quando uma atmosfera de gás explosiva.
11. Nenhuma revisão deste desenho CONTROL é permitida sem autorização dos órgãos listados.
12. Para aprovações de libertação ver ECO # 0094464.

Honeywell	A / A4	50091227		
	SCALE: None	REV C	DATE 06-9-2015	SH. 2 of 5

HART/DE

TERMINAL	ENTITY PARAMETERS	ASSOCIATED APPARATUS
1,2 (LOOP)	U_i or $V_{max} \leq 30V$	U_o, V_{oc} or $V_t \leq 30V$
	I_i or $I_{max} \leq 225$ mA	I_o (I_{sc} or I_t) ≤ 225 mA
	P_i or $P_{max} = 0.9W$	$P_o \leq 0.9W$
	$C_i = 4$ nF	C_a or $C_o \geq C_{cable} + C_{STT750/STT850}$
5, 6, 7, 8, 9 (SENSOR- SEE Page 5)	$L_i = 0$ μH	L_a or $L_o \geq L_{cable} + L_{STT750/STT850}$
	$C_o = 39$ μF	----
	$L_o = 4.99$ H	----

NON-HAZARDOUS LOCATION

HAZARDOUS (CLASSIFIED) LOCATION

CLASS I, DIVISION 1, GROUPS A, B, C, D, E, F & G;
 ZONE 0 IIC & ZONE 2 IIC,
 CLASS I DIVISION 2, GROUPS A, B, C, D;

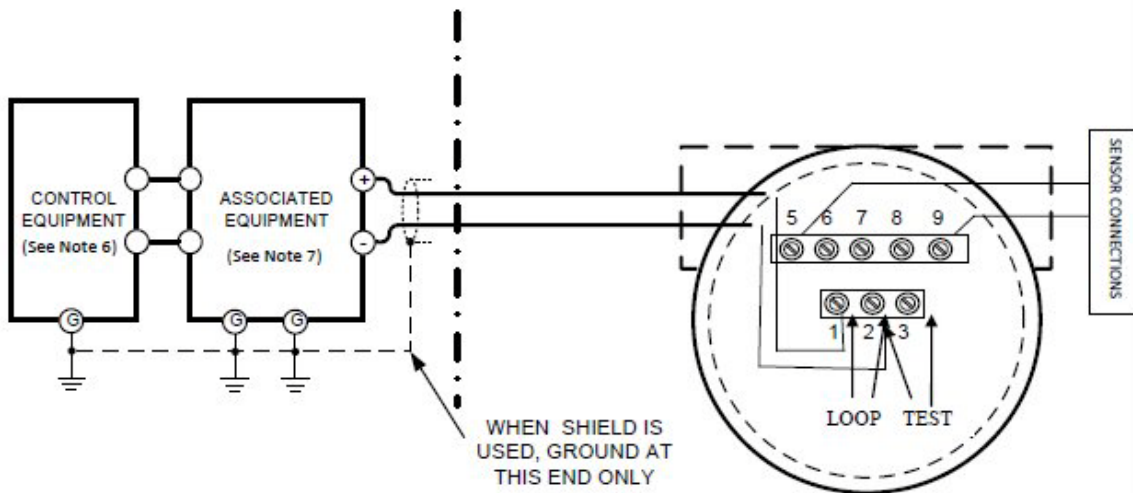

FOR DIV 2 / ZONE 2 INSTALLATIONS

CONTROL EQUIPMENT PARAMETERS

$U_{max} = U_i = 42V, 4-20$ mA, $P_o \leq 1$ W

NOTE : ASSOCIATED EQUIPMENT NOT REQUIRED

Honeywell

A/A4

50091227

SCALE: None

REV C

DATE 06-9-2015

SH. 3 of 5

SENSOR CONNECTIONS

Single Input

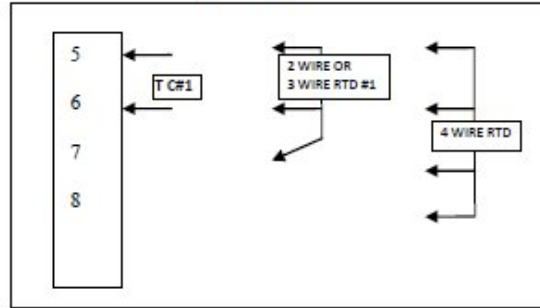

Dual Input

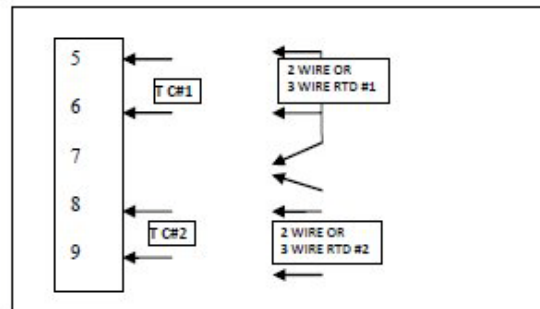

Note:

1. DUAL INPUT OPTION IS ONLY AVAILABLE WITH HART/ DE COMMUNICATIONS ON THE STT850.

Honeywell	A/A4	50091227		
SCALE: None	REV C	DATE 06-9-2015	SH. 5 of 5	

9. Appendix B – Security

8.2. How to report security vulnerability

For the purpose of submission, a security vulnerability is defined as a software defect or weakness that can be exploited to reduce the operational or security capabilities of the software or device. Honeywell investigates all reports of security vulnerabilities affecting Honeywell products and services.

To report potential security vulnerability against any Honeywell product, please follow the instructions at:

<https://honeywell.com/pages/vulnerabilityreporting.aspx>

Submit the requested information to Honeywell using one of the following methods:

- Send an email to security@honeywell.com.

Or

- Contact your local Honeywell Process Solutions Customer Contact Centre (CCC) or Honeywell Technical Assistance Centre (TAC) listed in the “Support and Contact information” section of this document.

Glossary

AWG	American Wire Gauge
EMI	Electromagnetic Interference
FTA	Field Termination Assembly
Hz	Hertz
LRL	Lower Range Limit
LRV	Lower Range Value
mAdc	Milliamperes Direct Current
mV	millivolts
Nm	Newton meters
NVM	Non-Volatile Memory
PM	Process Manager
PV	Process Variable
PWA	Printed Wiring Assembly
RFI	Radio Frequency Interference
RTD	Resistance Temperature Detector
T/C	Thermocouple
URL	Upper Range Limit
URV	Upper Range Value
US	Universal Station
Vac	Volts Alternating Current
Vdc	Volts Direct Current

Index

A	<p>About This Manual.....iii</p> <p>Accuracy.....5</p> <p>Application Design5</p>	I	<p>Input Sensor Wiring14</p> <p>Installation and Startup.....7</p> <p style="padding-left: 20px;">Display Installation Precautions 7</p> <p style="padding-left: 20px;">Mounting STT750 Temperature Transmitters 7</p> <p style="padding-left: 20px;">Site evaluation 7</p> <p>Installation Site Evaluation</p> <p style="padding-left: 20px;">Site Evaluation 7</p> <p>Introduction1</p>
B	<p>Bracket Mounting9</p>	M	<p>Maintenance27</p> <p style="padding-left: 20px;">Preventive Maintenance Practices and Schedules .. 27</p> <p style="padding-left: 20px;">Replacing the Communication Module 27</p> <p>MCToolkit.....7</p> <p>Monitoring the Display26</p> <p>Monitoring the Displays</p> <p style="padding-left: 20px;">Display 26</p> <p>Mounting Dimensions.....9</p> <p>Mounting STT 750 Temperature Transmitters</p> <p style="padding-left: 20px;">.....8</p> <p style="padding-left: 20px;">Bracket Mounting Procedure 9</p> <p style="padding-left: 20px;">Mounting Dimentsions 8</p> <p style="padding-left: 20px;">Summary 8</p>
C	<p>Calibration Procedures.....31</p> <p>Changing the Default Failsafe Direction24</p> <p style="padding-left: 20px;">Failsafe Operation24</p> <p>Copyrights, Notices and Trademarks.....ii</p>		
D	<p>Diagnostic Messages5</p> <p>Display Installation Precautions.....7</p> <p>Display Options.....4</p>		
E	<p>Explosion-Proof Conduit Seal13</p>	N	<p>Name Plate.....3</p>
F	<p>Features and Options1</p> <p style="padding-left: 20px;">Functional Characteristics2</p> <p style="padding-left: 20px;">Physical Characteristics1</p>	O	<p>Operation17</p> <p style="padding-left: 20px;">Changing the Default Failsafe Direction 24</p> <p style="padding-left: 20px;">Three Button Operation with no Display Installed .. 23</p> <p style="padding-left: 20px;">Three-Button Operation 17</p> <p>Optional 3-Button Assembly.....4</p>
G	<p>Glossary.....51</p> <p>Grounding and Lightning Protection13</p>	P	<p>Parts List.....34</p> <p>Patent Notice.....iv</p> <p>PRODUCT CERTIFICATIONS.....38</p>
H	<p>Honeywell MC Toolkit.....7</p>		

R

References.....	iv
Release Information.....	iii

S

Safety	5
Accuracy.....	5
Diagnosis Messages	5
Safety Certification	3
Startup	15
Constant Current Source Mode Procedure.....	16
Output Check Procedures	15
Support and Contact Information	iv
Symbol Descriptions and Definitions	v

T

Telephone and Email Contacts.....	iv
Three Button Operation with no Display	
Installed.....	23
Span Adjustments	23
Zero Adjustments	23
Three-Button Operation.....	17
Data Entry.....	18
Display menu	20
Editing a Numeric Value	19
Menu Navigation	18
Transmitter Adjustments	3
Transmitter Calibration	31
Troubleshooting	33
Critical Diagnostics Screens	33

W

Wiring a Transmitter	10
Wiring Procedure	12
Wiring Variations.....	12

Sales and Service

For application assistance, current specifications, pricing, or name of the nearest Authorized Distributor, contact one of the offices below.

ASIA PACIFIC

Honeywell Process Solutions,
(TAC) hfs-tac-support@honeywell.com

Australia

Honeywell Limited
Phone: +(61) 7-3846 1255
FAX: +(61) 7-3840 6481
Toll Free 1300-36-39-36
Toll Free Fax:
1300-36-04-70

China – PRC - Shanghai

Honeywell China Inc.
Phone: (86-21) 5257-4568
Fax: (86-21) 6237-2826

Singapore

Honeywell Pte Ltd.
Phone: +(65) 6580 3278
Fax: +(65) 6445-3033

South Korea

Honeywell Korea Co Ltd
Phone: +(822) 799 6114
Fax: +(822) 792 9015

EMEA

Honeywell Process Solutions,
Phone: + 80012026455 or
+44 (0)1344 656000

Email: (Sales)

FP-Sales-Apps@Honeywell.com

or

(TAC)

hfs-tac-support@honeywell.com

AMERICA'S

Honeywell Process Solutions,
Phone: (TAC) 1-800-423-9883 or
215/641-3610
(Sales) 1-800-343-0228

Email: (Sales)

FP-Sales-Apps@Honeywell.com

or

(TAC)

hfs-tac-support@honeywell.com

For more information
To learn more about SmartLine Transmitters,
visit www.honeywellprocess.com
Or contact your Honeywell Account Manager

Process Solutions
Honeywell
1250 W Sam Houston Pkwy S
Houston, TX 77042

Honeywell Control Systems Ltd
Honeywell House, Skimped Hill Lane
Bracknell, England, RG12 1EB
Shanghai City Centre, 100 Jungi Road
Shanghai, China 20061

www.honeywellprocess.com

Honeywell

34-TT-25-13 Rev.1
August 2015
©2015 Honeywell International Inc.