

STT 750 SmartLine Temperature Transmitter Quick Start Installation Guide

34-TT-25-14, Revision 1, August 2015

This document provides descriptions and procedures for the Quick Installation of Honeywell's family of SmartLine Temperature Transmitters.

The SmartLine Temperature Transmitter is available in a variety of models for measuring Ohms, mV and temperature from RTD's and thermocouples.

For full details refer to the manuals listed below for Protocol, User Interface (HMI) Operation, Installation, Configuration, Calibration, Maintenance, Parts, Safety and Approvals etc. including options.

Various other documents are available on the CD supplied with your shipment.

Documents in hardcopy can also be ordered.

Copyrights, Notices and Trademarks

Copyright 2015 by Honeywell
Revision 1, August 2015

Trademarks

SFC, SmartLine, STT750 are U.S. registered trademarks of Honeywell Inc.

HART® is a trademark of FieldComm Group™

Revision history
Rev.1 – 1 st release

References

The following list identifies all documents that may be sources of reference for material discussed in this publication.

Document Title	Document #
STT 750 SmartLine Transmitter User's Manual	34-TT-25-13
STT 750 SmartLine Transmitter HART User Manual	34-TT-25-15
SmartLine Temperature Safety Manual	34-TT-25-05
STT 750 Pocket Configuration Guide	34-TT-00-02
STT 750 Specification	34-TT-03-16
MC Toolkit User Manual (MCT202)	34-ST-25-20
MC Toolkit User Manual (MCT404)	34-ST-25-50

Table of Contents

Installation	3
Features and options.....	3
Mounting the Transmitter	4
Bracket Mounting	5
Optional Mounting Bracket.....	6
Conduit Entry Plugs and Adapters	7
Wiring Connections and Power Up.....	8
Wiring Variations	10
Input Sensor Wiring.....	10
Explosion-Proof Conduit Seal	11
Set the Jumpers For HART	12
Setting Failsafe Direction and Write Protect Jumpers	12
Configuration Guide	14

Tables

Table 1 - Jumper Settings	13
Table 2 – Available Display Characteristics	14
Table 3 – Basic Display Configuration.....	14

Figures

Figure 1 – Electronics Housing Components	3
Figure 2: Mounting Brackets	4
Figure 3 - Angle Mounting Brackets.....	5
Figure 4: Pipe Mounting Bracket Secured to a Horizontal or Vertical Flat Pipe.....	6
Figure 5 - Pipe Mounting Bracket secured to a Horizontal or Vertical Angle Pipe.....	6
Figure 6: Electronic Housing Conduit Entries.....	7
Figure 7: HART Transmitter Operating Ranges	8
Figure 8: Transmitter 9-Screw Terminal Board and Grounding Screw	9
Figure 9 – STT 750 Thermocouple, RTD, mV, ohm and Volt Connections.....	10
Figure 10: Jumper Location HART	13

INSTALLATION

Evaluate the site selected for the Transmitter installation with respect to the process system design specifications and Honeywell's published performance characteristics for your particular model.

Temperature extremes can affect display quality. The display can become unreadable at temperature extremes; however, this is only a temporary condition. The display will again be readable when temperatures return to within operable limits.

FEATURES AND OPTIONS

The STT 750 is packaged in one major assembly: the Electronics Housing.

The elements in the Electronic Housing are connected to the process sensors, measure the process variables, respond to setup commands and execute the software and protocol for the different temperature measurement types. [Figure 2](#) shows the assemblies in the Electronics Housing with available options.

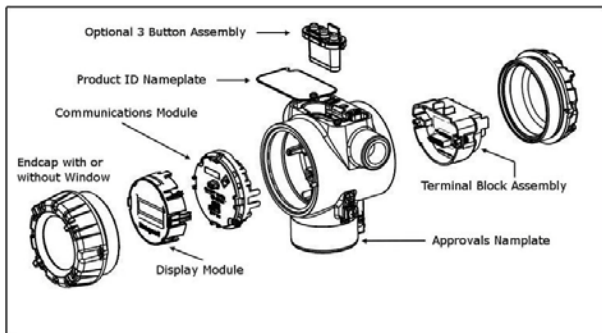

Figure 1 – Electronics Housing Components

The Transmitter measures process Temperature and outputs a signal proportional to the measured process variable (PV), including 4 to 20mA.

An optional 3-button assembly is located under the nameplate and provides a user interface and operation capability without opening the transmitter to set up and make adjustments to the Transmitter.

MOUNTING THE TRANSMITTER

Transmitter models can be attached to a two-inch (50 millimeter) vertical or horizontal flat pipe using Honeywell's optional angle; alternately you can use your own bracket. Honeywell's optional wall mounting bracket is also shown below:

For Housing with Adaptor refer to Honeywell drawings 50095917 (Flat pipe mount) and 50095918 (Wall mount) for detailed mounting specifications.

For Housing without adaptor refer to Honeywell drawings 32306827 (No-Adaptor, Flat pipe mount) and 32306828 (No-adaptor, Wall mount).

Figure 2 and Figure 3 shows typical bracket-mounted installations.

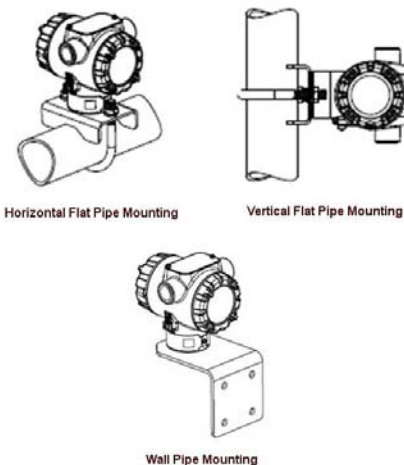
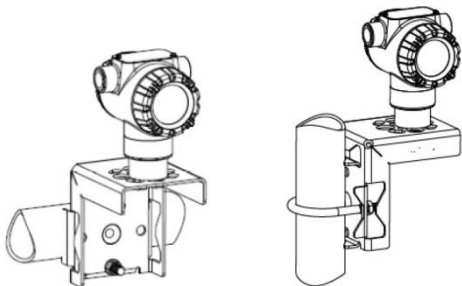

Figure 2: Mounting Brackets



Horizontal Angle Pipe Mounting Vertical Angle Pipe Mounting
Figure 3 - Angle Mounting Brackets

Bracket Mounting

If you are using an optional bracket, start with Step 1.

1. Align the two mounting holes in the transmitter with the two slots in the mounting bracket and assemble the (2) M8 hex cap screws, (2) lockwashers and (2) flat washers provided. Rotate transmitter assembly to the desired position and torque the M8 hex cap screws to 27,0 Nm/20,0 Lb-ft maximum.
2. Pipe Mount Option: Refer to [Figure 2](#) and [Figure 3](#). Position the bracket on a 2-inch (50.8 mm) horizontal or vertical pipe, and install a "U" bolt around the pipe and through the holes in the bracket. Secure the bracket with the nuts, flat washers and lock washers provided.
3. Wall Mount Option: Position the bracket on the mounting surface at the desired location and secure the bracket to the mounting surface using the appropriate hardware (Wall mounting hardware requirements to be determined and supplied by the end user). Existing mounting bracket, see [Figure 2](#) and [Figure 3](#)

For Housings with and without Adapter refer to Honeywell drawing #50124813 (Angle pipe mounting) for detailed specifications.

Optional Mounting Bracket

Position bracket on 2-inch (50.8 mm) and install "U" bolt around pipe and through holes in bracket. Secure with nuts and lock washers provided. Optional mounting bracket, see [Figure 4](#) and [Figure 5](#).

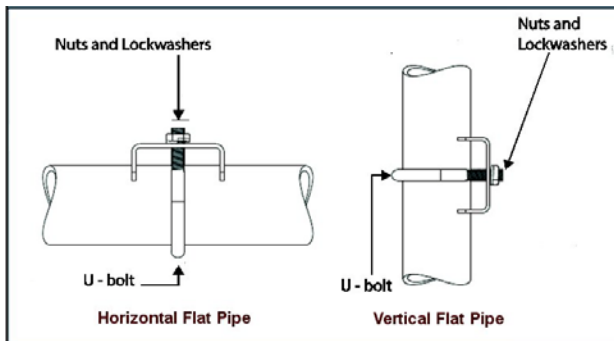

Figure 4: Pipe Mounting Bracket Secured to a Horizontal or Vertical Flat Pipe

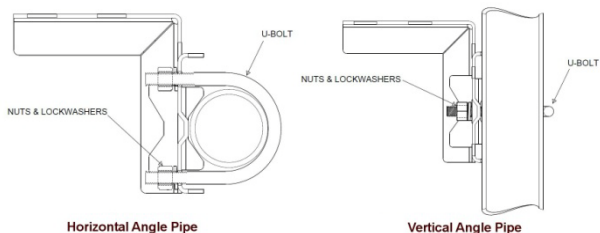

Figure 5 - Pipe Mounting Bracket secured to a Horizontal or Vertical Angle Pipe

CONDUIT ENTRY PLUGS AND ADAPTERS

Procedures

It is the User/Installer's responsibility to install the Transmitters in accordance with national and local code requirements. Conduit entry plugs and adapters shall be suitable for the environment, shall be certified for the hazardous location when required and acceptable to the authority having jurisdiction for the plant.

CONDUIT ENTRY PRECAUTIONARY NOTICE

THE CONDUIT/CABLE GLAND ENTRIES OF THIS PRODUCT ARE SUPPLIED WITH PLASTIC DUST CAPS WHICH ARE NOT TO BE USED IN SERVICE. IT IS THE USER'S RESPONSIBILITY TO REPLACE THE DUST CAPS WITH CABLE GLANDS, ADAPTORS AND/OR BLANKING PLUGS WHICH ARE SUITABLE FOR THE ENVIRONMENT INTO WHICH THIS PRODUCT WILL BE INSTALLED. THIS INCLUDES ENSURING COMPLIANCE WITH HAZARDOUS LOCATION REQUIREMENTS AND REQUIREMENTS OF OTHER GOVERNING AUTHORITIES AS APPLICABLE.

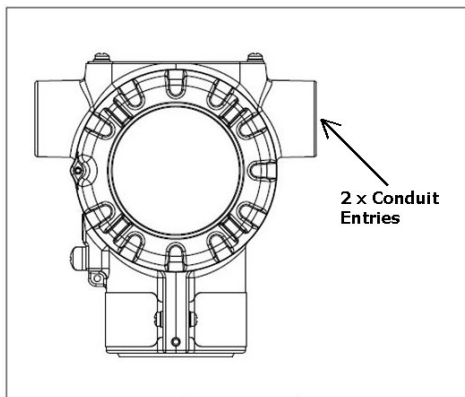

Figure 6: Electronic Housing Conduit Entries

Note. No plugs come installed in the housings. All housings come with temporary plastic dust protectors (red) installed and are not certified for use in any installation.

WIRING CONNECTIONS AND POWER UP

Summary

The transmitter is designed to operate in a two-wire power/current loop with loop resistance and power supply voltage within the HART operating range shown in Figure 7.

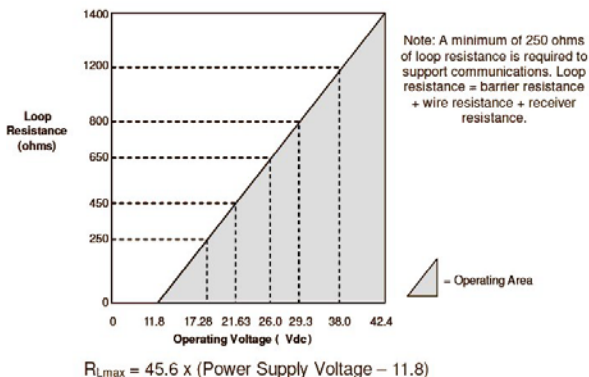

Figure 7: HART Transmitter Operating Ranges

Loop wiring is connected to the Transmitter by simply attaching the positive (+) and negative (-) loop wires to the positive (+) and negative (-) terminals on the Transmitter terminal block in the Electronics Housing shown in Figure 7.

Connect the Loop Power wiring shield to earth ground only at the power supply end.

Note that the Transmitter is not polarity-sensitive.

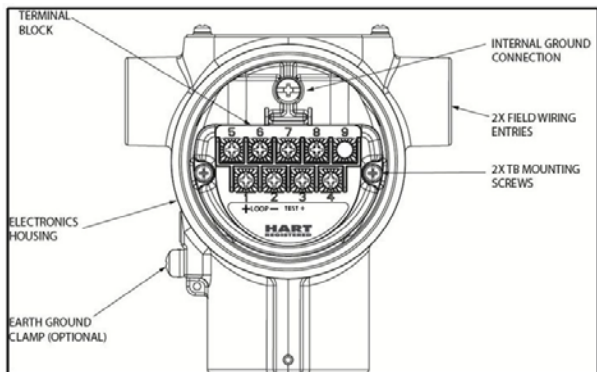

Figure 8: Transmitter 9-Screw Terminal Board and Grounding Screw

As shown in [Figure 8](#), each transmitter has an internal terminal to connect it to earth ground. Optionally, a ground terminal can be added to the outside of the Electronics Housing. Grounding the transmitter for proper operation is required, as doing so tends to minimize the possible effects of noise on the output signal and affords protection against lightning and static discharge.

An optional lightning terminal block can be installed in place of the non-lightning terminal block for transmitters that will be installed in areas that are highly susceptible to lightning strikes. As noted above, the Loop Power wiring shield should only be connected to earth ground at the power supply end.

Note: Terminal pin 9 is not used.



Wiring must comply with local codes, regulations and ordinances. Grounding may be required to meet various approval body certification, for example CE conformity. Refer to Appendix A of this document for details.

Note: Terminal #3 is for loop test

The Transmitter is designed to operate in a two-wire power/current loop with loop resistance and power supply voltage within the operating range; see [Figure 6](#).

With an optional remote meter, the voltage drop for this must be added to the basic power supply voltage requirements to determine the required Transmitter voltage and maximum loop resistance. Additional consideration is required when selecting intrinsic safety barriers to ensure that they will supply at least minimum Transmitter voltage, including the required 250 ohms of resistance (typically within the barriers) needed for digital communications.

Wiring Variations

The above procedures are used to connect power to a Transmitter. For loop wiring and external wiring, detailed drawings are provided for Transmitter installation in non-intrinsically safe areas and for intrinsically safe loops in hazardous area locations. This procedure shows the steps for connecting power to the transmitter.



Wiring must comply with local codes, regulations and ordinances. Grounding may be required to meet various approval body certification, for example CE conformity. Refer to the STT 750 SmartLine Transmitter User's Manual 34-TT-25-13 for details.

Input Sensor Wiring

Connect the input sensors as shown in Figure below:

Figure 9 – STT 750 Thermocouple, RTD, mV, ohm and Volt Connections

- Ohm and Resistance temperature detector (RTD) measurements use the 3 or 4 wire approach.

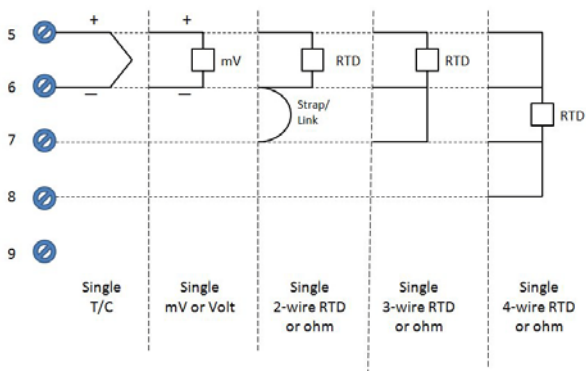

Figure 9 – STT 750 Thermocouple, RTD, mV, ohm and Volt Connections

EXPLOSION-PROOF CONDUIT SEAL



When installed as explosion proof in a Division 1 Hazardous Location, keep covers tight while the Transmitter is energized. Disconnect power to the Transmitter in the non-hazardous area prior to removing end caps for service.

When installed as non-incendive equipment in a Division 2 hazardous location, disconnect power to the Transmitter in the non-hazardous area, or determine that the location is non-hazardous before disconnecting or connecting the Transmitter wires.

Transmitters installed as explosion proof in Class I, Division 1, Group A Hazardous (classified) locations in accordance with ANSI/NFPA 70, the US National Electrical Code, require a LISTED explosion proof seal to be installed in the conduit, within 18 inches (457.2 mm) of the Transmitter. Crouse-Hinds type EYS/EYD or EYSX/EYDX are examples of LISTED explosion proof seals that meet this requirement.

Transmitters installed as explosion proof in Class I, Division 1, Group B, C or D hazardous (classified) locations do not require that explosion proof seal be installed in the conduit.

Step	Action
1	See Figure 8 , above, for parts locations. Loosen the end cap lock using a 1.5 mm Allen wrench.
2	Remove the end cap cover from the terminal block end of the Electronics Housing
3	Feed loop power leads through one end of the conduit entrances on either side of the Electronics Housing. The Transmitter accepts up to 16 AWG wire.
4	Connect the positive loop power lead to the positive (+) terminal and the negative loop power lead to the negative (-) terminal. Note that the Transmitter is not polarity-sensitive.
5	Feed input sensor wires through the 2 nd conduit entrance and connect wire per Figure 7 and Figure 8 .
6	Replace the end cap, and secure it in place

SET THE JUMPERS FOR HART

Setting Failsafe Direction and Write Protect Jumpers

The SmartLine Temperature Transmitter provides two jumpers to set the desired failsafe action and Write Protect option. See [Figure 10](#)

The top jumper on the electronics module sets the Failsafe direction. The default setting is up-scale failsafe.

Up Scale drives the loop to a value greater than 21.5mA while Down Scale drives the loop to a value less than 3.5mA.

You can change the failsafe direction by moving the Failsafe Jumper (top jumper) to the desired position (UP or DOWN).

The bottom jumper sets the Write Protect. The default setting is OFF (Un-protected).

When set to the On (Protected) position, Changed configuration parameters cannot be written to the transmitter.

When set to the OFF (Un-protected) position, Changed configuration parameters can be written to the transmitter.

	ATTENTION: Electrostatic Discharge (ESD) hazards. Observe precautions for handling electrostatic sensitive devices
Step	Action
1	Turn OFF Transmitter power.
2	Loosen the end-cap lock, and unscrew the end cap from the Electronics side of the Transmitter housing.
3	If there is a Display module, carefully depress the tabs on the sides of the Display Module and pull it off. If necessary, move the interface connector from the Communication Module. Do not discard connector
4	Set the Failsafe Jumper (top jumper) to the desired action (UP or DOWN). And the Write Protect jumper (Bottom jumper) to the desired behavior (Protected or Unprotected) See Table 1 for jumper positioning.
5	If applicable, re-install the Display module as follows: <ul style="list-style-type: none"> • Orient the display as desired. • Install the Interface Connector in the Display module such that it will mate with the socket for the display in the Communication module. • Carefully line up the display, and snap it into place. Verify that the two tabs on the sides of the display latch.
6	Screw on the end cap and tighten the end-cap lock. Turn ON Transmitter power.

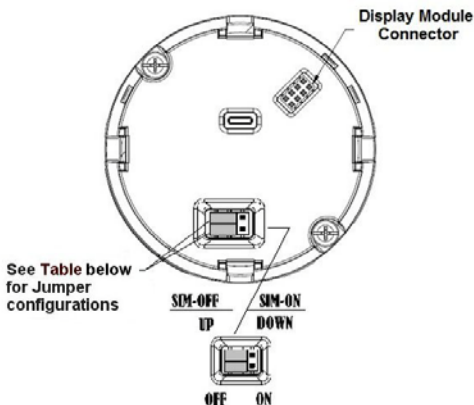

Figure 10: Jumper Location HART

Jumper Settings	Description
	<i>Failsafe = UP (High)</i> <i>Write Protect = OFF (Not Protected)</i>
	<i>Failsafe = DOWN (Low)</i> <i>Write Protect = OFF (Not Protected)</i>
	<i>Failsafe = UP (High)</i> <i>Write Protect = ON (Protected)</i>
	<i>Failsafe = DOWN (Low)</i> <i>Write Protect = ON (Protected)</i>

Table 1 - Jumper Settings

CONFIGURATION GUIDE

Table 2 shows the transmitter Basic Display Configuration. Use these tables to configure the transmitter.

Table 2 – Available Display Characteristics

Basic Display	<ul style="list-style-type: none"> Suitable for basic process needs 360° rotation in 90° increments 8 configurable screens 2 lines, 16 characters Standard units of measurement: °F, °C, °R, K, Ω, mV & % Diagnostic messaging
---------------	--

Table 3 – Basic Display Configuration

Note: "#" indicates selected screen number 1 - 8

LCD Contrast	»»»»»	Adjust the LCD contrast level. Range from » (1) to »»»»»»»»» (9) Default: »»»»»»»» (7)	Press ↵ to enter menu selection ↑ and ↓ to select entry. ↵ to enter
Rotation Time			
Screen Rotate	Enabled Disabled	Select to enable or disable the automatic rotation of Screens	
Select Screen	1 through 8	Select Screen to configure.	
Screen #	Enabled/Disabled	Select to enable or disable the screen for display and configuration	
Screen # PV	Sensor Loop PV CJ Temperature Sensor Resistance Loop Output Percent Output	Select the Process Variable (PV) that will be shown on the screen. Sensor Resistance is only available for RTDs and will read 0 for thermocouples	
Screen # Decimal	None X.X X.XX X.XXX	Select the PV decimal resolution to be shown on selected screen from list.	

Screen # Units (Writable for TC and RTD sensor types only)	°C, °F, °R, K	Choose appropriate engineering units from list	Press \leftarrow to enter menu selection \uparrow and \downarrow to select entry. \leftarrow to enter
Range/Cal Units (Visible for TC and RTD sensor types only)	°C, °F, °R, K	Select the ranging and calibration temperature units	
Sensor Type	mV, TC, RTD, Ohm	Select Sensor Type	
Sensor ID	Sensor Identifier	Select Sensor ID for Input n for selected Sensor Type. (Input selection)	
RTD Type (Visible for RTD sensor type only)	2-Wire, 3-Wire, 4-Wire	Select the RTD Type according to the number of lead wires	
RTD Lead Wire (Visible for RTD sensor type and 2-wire RTD type only)	####.##	Resistance value of the sensor lead wire. (only if RTD type is 2 wire)	
Sensor Bias	####.##	Bias on the measured value	
Sensor Cal Lo Pt	####.##	Calibration low point for Sensor n	
Sensor Cal Hi Pt	####.##	Calibration high point for Sensor n	
Do Sensor Cal Lo	Confirm	Executing this selection corrects the Cal Low Point based on the input measurement	
Do Sensor Cal Hi	Confirm	Executing this selection corrects the Cal High Point based on the input measurement	

Sensor LRV	####.##	Lower Range Value representing 0% output	Read Only Parameter
Sensor URV	####.##	Upper Range Value representing 0% output	Read Only Parameter
Reset Sensor Cal	Confirm	Executing this selection Resets the LRV, and URV Corrects back to Factory values	Press \leftarrow to enter menu selection \uparrow and \downarrow to select entry. \leftarrow to enter
Break Detect	Enable, Disable	Enable or disable detection of Input wire break	
Latching	Enable, Disable	When enabled, causes all critical sensor input failures to latch to the Critical Fault state. The fault may only be cleared by device reset. When disabled, the critical sensor input failure will be cleared if the input recovers.	
CJ Type	Internal, Fixed	Determines the source of the Cold Junction compensation for thermocouple Sensor types.	
Fixed CJ Value (Visible for TC input only)	####.##	When CJ Type is Fixed, specifies the Cold Junction temperature value for thermocouple Sensor types. Degrees Celsius. Fixed CJ temperatures below -50 degrees have no effect on measured values.	
LRV URV	#. ## #. ##	The limits are: the Lower Range Limit (LRL) and the Upper Range Limit (URL) of the selected Sensor 1 ID	

Set LRV	Set Lower Range Value	ATTENTION: Executing this service will set the Lower Range Value (LRV) equal to the input pressure	Press \leftarrow to enter menu selection \uparrow and \downarrow to select entry. \leftarrow to enter
Set URV	Set Upper Range Value	ATTENTION: Executing this service will set the Upper Range Value (URV) equal to the input pressure	
Damping	#. ##	Selection applies digital filtering to suppress noise effects on the PV. The limits for this value are 0.0 to 102.0 seconds	
NAMUR Output	Enabled Disabled	Disabling sets the loop output and burnout levels to the Honeywell levels	
DAC Zero Trim Note: Loop must be removed from Automatic Control	DAC Zero Trim	This selection allows the loop zero output 4mA value to be trimmed. Note: You must connect a current meter to the transmitter to monitor the loop output.	
DAC Span Trim Note: Loop must be removed from Automatic Control	DAC Span Trim	This selection allows the loop span output 20mA value to be trimmed. Note: You must connect a current meter to the transmitter to monitor the loop output.	
Loop Test Note: Loop must be removed from Automatic Control	Loop Test 12.000	This selection allows the user to force the DAC output to any value between 3.8 and 20.8 mA. Note: This selection will put the DAC into Fixed Output Mode, as indicated by the flashing output value. Navigation away from this menu item will return the loop to Normal (Automatic) Mode.	

Tag ID	□□□□□□□□	Enter Tag ID name up to 8 characters long. □ = any Alphanumeric value	Tag ID
HART Device ID	Unique for each device	Unique ID for device	Read Only Parameter
HART PV Units	Units of transmitted PV	Units for the Primary Variable (Writable - for TC/RTD Sensor type, Read only - mV and Ohm Sensor type)	Press ↵ to enter menu selection ↑ and ↓ to select entry. ↵ to enter
HART SV Units	Units of transmitted SV	Units for the Secondary Variable	
Install Date	DD MM YYYY	This selection allows the user to enter the date a transmitter is installed. The Install Date is entered in sequence of Day, Month, and Year, followed by the new date and the prompt Write Date to confirm the entry. CAUTION: The Install Date can only be written once in the life of the Transmitter. You cannot erase or overwrite the Install Date once it has been written.	Press ↵ to enter menu selection ↑ and ↓ to select entry. ↵ to enter
Firmware	Display Electronics Sensor	Menu item shows the current Firmware versions of the Display, Electronics Module and the Sensor Module	Read Only Parameter
Protocol	HART	Menu item shows the communications protocol	Read Only Parameter
Model Key		Identifies the type and range of the transmitter	Read Only Parameter
<Exit Menu>			

Sales and Service

For application assistance, current specifications, pricing, or name of the nearest Authorized Distributor, contact one of the offices below.

ASIA PACIFIC (TAC)

Australia Honeywell Limited, Phone: +(61) 7-3846 1255, FAX: +(61) 7-3840 6481
Toll Free 1300-36-39-36, Toll Free Fax: 1300-36-04-70

China – PRC – Shanghai, Honeywell China Inc. Phone: (86-21) 5257-4568,
Fax: (86-21) 6237-2826

Singapore, Honeywell Pte Ltd. Phone: +(65) 6580 3278. Fax: +(65) 6445-3033

South Korea, Honeywell Korea Co Ltd. Phone:+(822)799 6114. Fax:+(822) 792 9015

EMEA, Phone: + 80012026455 or +44 (0)1202645583. FAX: +44 (0) 1344 655554

Email: (Sales) sc-cp-apps-salespa62@honeywell.com

or (TAC) hfs-tac-support@honeywell.com

AMERICAS Honeywell Process Solutions, Phone: 1-800-423-9883,

Or 1-800-343-0228. Email: (Sales) ask-ssc@honeywell.com

or (TAC) hfs-tac-support@honeywell.com

WARRANTY/REMEDY

Honeywell warrants goods of its manufacture as being free of defective materials and faulty workmanship. Contact your local sales office for warranty information.

If warranted goods are returned to Honeywell during the period of coverage, Honeywell will repair or replace without charge those items it finds defective. The foregoing is Buyer's sole remedy and is **in lieu of all other warranties, expressed or implied, including those of merchantability and fitness for a particular purpose.**

Specifications may change without notice. The information we supply is believed to be accurate and reliable as of this printing. However, we assume no responsibility for its use.

While we provide application assistance personally, through our literature and the Honeywell web site, it is up to the customer to determine the suitability of the product in the application.

Honeywell

Honeywell Process Solutions

1860 West Rose Garden Lane

Phoenix, Arizona 85027

www.honeywellprocess.com

34-TT-25-14 Rev.1

August 2015

©2015 Honeywell International Inc.