

SEM1020

(4 to 20) mA Isolator/Loop Booster



<http://fluidic-ltd.co.uk/product/status-galvanic-isolators/>

INDEX

SECTION	CONTENTS	PAGE NO.
1.0	DESCRIPTION	1
2.0	SPECIFICATION	1
3.0	INSTALLATION	2
4.0	OPERATION	3
5.0	CALIBRATION	3
6.0	MECHANICAL	3

1.0 DESCRIPTION

The SEM1020 isolator is designed for use when power is available at both sides of the isolation barrier.

2.0 SPECIFICATIONS

2.1 INPUT

Type	Current input 2 wire loop powered
Range	(4 to 20) mA (30 mA max.)
Protection	Reverse connection
Voltage Drop	2.7 V maximum
Max. Loop Volts	35 V

2.2 OUTPUT

Type	2 wire Current Sink (4 to 20) mA
Loop Voltage	(5 to 32) VDC (reverse protected)

Loop Volt Drop = 2.7 V	Load = 900 Ω @ $V_s=24$ V
	Load = 1200 Ω @ $V_s=30$ V

Loads must be > 250 Ω for ambients > 50 °C

2.3 GENERAL SPECIFICATION @20°C

Isolation	500 VAC (flash tested @ 1 kV) (Isolation method, opto coupler/transformer)
Environment	BS EN61010-1 Pollution Degree 2; Installation CAT II; CLASS I
Ambient	(0 to 70) °C; (10 to 95) % RH non condensing
Linearity	0.05 %
Stability	0.01 %/°C
Response Time	Less than 100 ms to reach 70 % of final value.
EMC Tested to	IEC 801-2 Susceptibility to E.S.D. IEC 801-3 Radiated Susceptibility IEC 801-4 Susceptibility to conducted interference EN55022 Radiated Emissions
Connection	Captive clamp screws
Cable Size	Maximum 4 mm ² solid / 2.5 mm ² stranded
Case Material	Grey Polyamide
Flammability	To UL94-VO VDE 0304 Part 3, Level IIIA
Dimensions	Case A: (60 x 60 x 12.5) mm (67.5 mm above rail)
Mounting	Snap on "Top Hat" rail (DIN EN 50022-35)
Adjustment	Front Entry Fine Zero and Span Adjustment

3.0 INSTALLATION

3.1 MECHANICAL

This isolator is designed to be housed within a suitable enclosure that will provide protection from the external environment, and ensure the stated temperature and humidity ranges are not exceeded. The isolator case is designed to snap fit onto a standard "Top Hat" DIN rail. The isolator may be removed if required by applying pressure with one hand, to the bottom face of the enclosure, in a direction parallel with the DIN rail and at the same time gripping the top of the isolator and pulling away from the rail. The isolator may be mounted in any orientation and stacked side by side along the rail.

Incorrect connection in the loop will not damage the device as long as the specified maximum currents /voltages are not exceeded. If the isolator fails to operate, check loop for bad connections. Ensure enough voltage is available in the loop to power the isolator. In the unlikely event of the isolator not working, it should be returned to the supplier for repair or replacement.

3.2 ELECTRICAL

Connections to the isolator are made via screw terminals. Wire protector plates are provided inside each terminal. To maintain compliance twisted pair (screened) cables are recommended. It is also good practice to ensure that all (4 to 20) mA loops are grounded at a single point in the loop. Before installation, care must be taken to ensure enough voltage is available in the loop to drive the total loop load. Refer to the specifications listed above for the loop drop voltage. The SEM1020 in most applications, requires a separate supply for the secondary loop, this may be provided from a separate power supply or from the instrument monitoring the output loop.

Refer to the SEM1000 series data sheet for further information on applications of this series of isolators. Please note the isolation provided by this device is only suitable for providing isolation between two process signals and therefore must not be used to provide isolation from hazardous voltages, such as mains supplies.

Figure 1

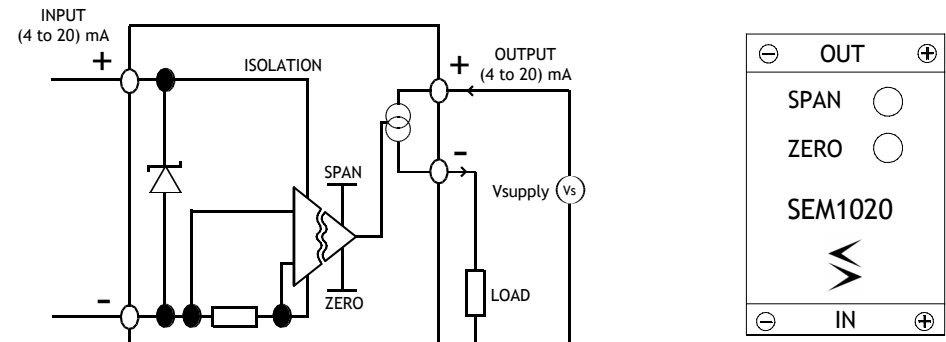

4.0 OPERATION

This isolator requires no user adjustment during commissioning, apart from an initial test, to ensure it operates correctly over its full working range. Minor adjustments can be made to the calibration of the device by means of the two front panel accessible calibration potentiometers.

5.0 CALIBRATION

1. Connect a precision current calibrator to the input, and a precision current meter in series with the output loop*1. Power output loop with 24 VDC.
2. Inject 4.000 mA \pm 0.001 mA into the input and adjust ZERO potentiometer for 4.000 mA \pm 0.001 mA output*2.
3. Inject 20.000 mA \pm 0.001 mA into the input and adjust SPAN potentiometer for 20.000 mA \pm 0.001 mA output*2.
4. Repeat steps 2 and 3 until both points are in calibration.

*NOTES:

1. Current calibrator must be capable of driving the expected loop drop.
2. Please note that the reading accuracies in 2 and 3 above are absolute values and do not include test equipment tolerances.

6.0 MECHANICAL DETAIL

Figure 2

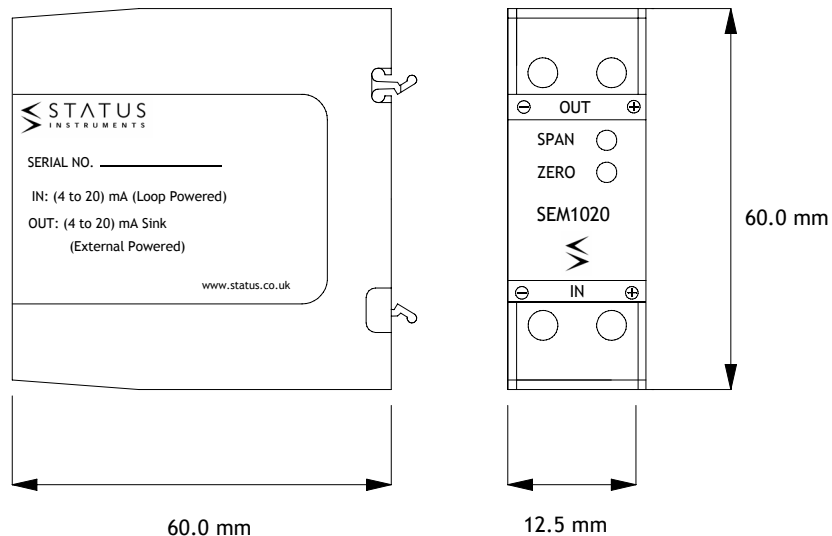

ALSO AVAILABLE:

- Smart In Head Temperature Transmitters
- DIN Rail Mounted Temperature Transmitters
- Panel & Field Temperature Indicators
- Temperature Probes
- Trip Amplifiers
- Signal Conditioners
- And many other products

For further information on all products:



<http://fluidic-ltd.co.uk/product/status-galvanic-isolators/>