

TEMPERATURE TRANSMITTERS

SEM203 TC

- SUITABLE FOR K, J, N, E, T, R, S THERMOCOUPLES PLUS mV
- SIMPLE PUSH BUTTON CONFIGURATION
- ADVANCED USER CONFIG FOR ACCESS TO 56 PRE SET TEMPERATURE RANGES
- USER PUSH BUTTON TRIM
- PROGRAMMABLE BURNOUT



➤ INTRODUCTION

The SEM203TC is a cost effective “smart” in head transmitter that accepts thermocouple temperature sensors and converts sensor output over a configured range to a standard industrial (4 to 20) mA transmission signal.

A simple push button operation allows the user to select TC type, Burnout direction, Select fixed ranges and trim (4 and 20) mA points.

The SEM203TC in head transmitter incorporates the latest digital technology to ensure accurate drift free performance.

If required the desired range can be specified at the time of order, removing the need for user configuration. If the range is not specified then the transmitter will be shipped with the default range of (0 to 1000) °C type K.

➤ PUSH BUTTON CONFIGURATION

User Range

Two level of configuration are available to the user, the first level user range, allows the user to re-range the transmitter.

This level is available under normal use and operates in a similar manner to the previous SEM203TC Product. The user can identify the input type set by counting the number of program led flashes on power up. The input type cannot be change at this level of configuration.

Advanced user configuration

In this level the single push button and two LED indicators are used the user to navigate the user through a series of five menus, allowing full configuration of the transmitter. The menus are as follow:-

- Menu 1 Select Input type K, J, N, E, R, S, T thermocouple or mV
- Menu 2 Select either user range set by USER RANGE or select one of seven (per input) fixed ranges
- Menu 3 Select burnout direction
- Menu 4 Trim output current at either 4 mA or 20 mA.
- Menu 5 Reset to factory default and clear user trim

➤ SPECIFICATIONS @ 20 ° C

INPUT

Sensor	Range (° C)	Accuracy
K	-200 to 1370	± 0.1% of F.S. ± 0.5 ° C (plus any sensor error)
J	-100 to 1200	± 0.1% of F.S. ± 0.5 ° C (plus any sensor error)
E	-200 to 1000	± 0.1% of F.S. ± 0.5 ° C (plus any sensor error)
N	-180 to 1300	± 0.1% of F.S. ± 0.5 ° C (plus any sensor error)
T	-200 to 400	± 0.2% of F.S. ± 0.5 ° C (plus any sensor error)
R	-10 to 1760	± 0.1% of F.S. ± 0.5 ° C (plus any sensor error) over range 800 to 1600
S	-10 to 1760	± 0.1% of F.S. ± 0.5 ° C (plus any sensor error) over range 800 to 1600
	Range (mV)	
mV	-10 to 70	± 0.02 % of full scale

Isolation Sensor Burnout Cold Junction

Tested to 250 V dc
Either up or down scale output
Range (-40 to 85) °C; Accuracy
±0.5 °C Tracking ± 0.05 °C / °C

Stability (-20 to 70)

at zero °C ± 0.15 °C / °C
at span ± 0.1 °C / °C

Typically for (-40 to -20)
and (70 to 85)

± 0.1 % of reading / °C

TEMPERATURE TRANSMITTERS

OUTPUT

Output Type	2 wire (4 to 20) mA current loop
Output range	4.0 mA to 20.0 mA
Output Connection	Screw Terminal
Maximum output	21.5 Ma (in high burnout condition)
Minimum output	3.8 mA (in low burnout condition)
Accuracy	(mA output / 2000) or 5 uA (Which ever is the greater)
Loop Voltage effect	± 0.2 uA / V
Thermal drift	± 2 uA / °C Typically ± 2 uA / °C Max
Maximum output load	[(Vsupply-12)/20] K Ohms (Example 600 ohms @ 24 V)

Fixed Ranges

Range	Inputs K, J, E, & N (°C)	Input T (°C)	Inputs R, & S (°C)	Input mV mV
1	User			
2	0 to 1000	0 to 400	800 to 1760	0 to 70
3	0 to 1200	0 to 250	800 to 1600	0 to 5
4	0 to 600	0 to 200	800 to 1400	0 to 10
5	0 to 500	0 to 150	1000 to 1760	0 to 20
6	0 to 250	0 to 100	1000 to 1600	0 to 25
7	0 to 100	0 to 50	1000 to 1400	0 to 50
8	-100 to 100	-100 to 150	0 to 1600	-10 to 10

GENERAL SPECIFICATION

Update time	500 mS
Response Time	1 second
Start up time	Within 8 Seconds (Output < 4 mA during start up)
Warm-up time	1 minute to full accuracy
Power Supply	(12 to 30) Volts dc

ENVIRONMENTAL

Ambient operating range	(-40 to +85) °C
Ambient storage temperature	(-50 to +90) °C
Ambient humidity range	(10 to 90) % RH non condensing

PHYSICAL

Dimensions	43 mm diameter; 21 mm height
Weight	31 g (encapsulated)

APPROVALS

EMC - BS EN 61326

Electrical equipment for measurement control and laboratory use.

ANNEX A

Immunity test requirements for equipment intended for use in industrial locations

ANNEX F

Test configurations, operational conditions and performance criteria for transducers with integrated or remote signal conditioning.

IEC 61000-4-2	Electrostatic discharge
IEC 61000-4-3	EM Field
IEC 61000-4-4	Transient Burst (output)
IEC 61000-4-5	Surge (output)

Note - Sensor input wires to be less than 3 metres to comply.

MECHANICAL

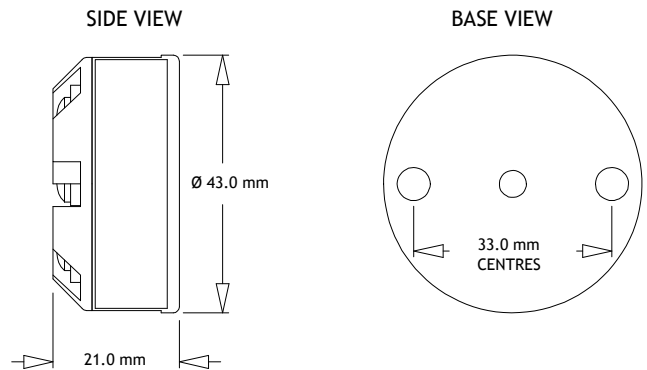

Mounting holes: two holes 5.5 mm diameter, 33 mm centres
Centre Hole sensor wire entry: 4 mm

WIRING CONNECTIONS

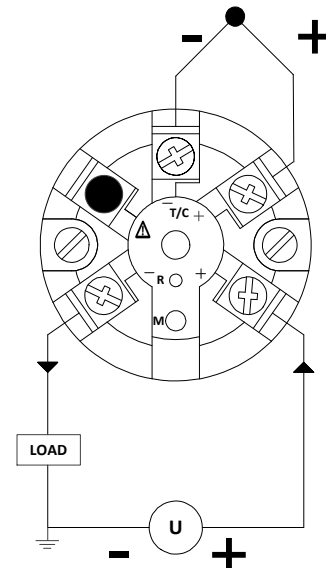

ORDER CODE: SEM 203TC

Distribution via
www.fluidic-ltd.co.uk
 Glasgow 0141 641 5920
 Warrington 01925 572401