

GUARDIAN LOW - MEDIUM - HIGH TEMPERATURE

T1700 & T1800 INDUSTRIAL & ATEX Exia CAPILLARY TEMPERATURE SWITCH

The standard range represents the basic models to cover temperature applications spanning -40 to +230°C. The T1700 is supplied fitted with a threaded thermowell, the T1800 has no thermowell but is supplied with a sliding gland. Capillary is 316 stainless steel armoured and is available from 2 to 10 metres in length. Dual microswitch options are available for simultaneous operation.

Deadband figures shown in the table below refer to single set points only, if dual microswitches are specified deadband may increase up to a factor of 2.

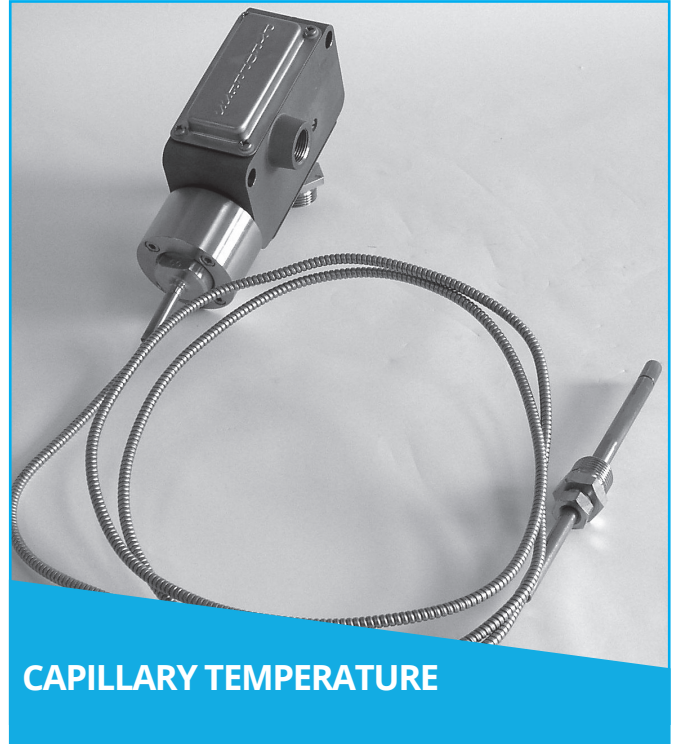

CAPILLARY TEMPERATURE

FEATURES

- ✓ 316 stainless steel or black anodised aluminium switchcase.
- ✓ IP66/IP67 certified housing.
- ✓ Internal adjustment scale.
- ✓ SIL2 - IEC61508 proven reliability.
- ✓ 316 stainless steel armoured capillary from 2 to 10 metres
- ✓ Single or dual microswitch option.
- ✓ Wetted parts NACE MR-01-75 option.
- ✓ ATEX Certified Option
CE II1G Ex ia IIC
T6 Tamb -50 to +78°C
T5 Tamb -50 to +93°C
T4 Tamb -50 to +128°C

| ADJUSTMENT RANGE (°C) | MAXIMUM TEMPERATURE (°C) | DEADBAND (°C) | CAPILLARY CODE | Min bulb length according to capillary length | | |
|-----------------------|--------------------------|---------------|----------------|---|---------|----------|
| | | | | 2m - 4m | 5m - 7m | 8m - 10m |
| -40 TO -10 | 40 | <10 | 40 | 100 | 100 | 100 |
| -15 TO +15 | 70 | <10 | 41 | 100 | 150 | 200 |
| 0 TO 30 | 80 | <10 | 42 | 100 | 150 | 200 |
| 20 TO 50 | 120 | <15 | 45 | 100 | 150 | 200 |
| 40 TO 70 | 145 | <15 | 43 | 100 | 100 | 100 |
| 60 TO 90 | 145 | <15 | 43 | 100 | 100 | 100 |
| 80 TO 110 | 145 | <15 | 43 | 100 | 100 | 100 |
| 100 TO 130 | 180 | <15 | 44 | 100 | 100 | 100 |
| 125 TO 155 | 180 | <15 | 44 | 100 | 100 | 100 |
| 150 TO 180 | 200 | <15 | 44 | 100 | 100 | 100 |
| 175 TO 205 | 280 | <15 | 46 | 100 | 100 | 100 |
| 200 TO 230 | 280 | <15 | 46 | 100 | 100 | 100 |

Repeatability : +/-1.5% of range (at operating temperature up to 40°C)
Calibration rate : without thermowell, at 2°C per minute rate of change.

Temperature Limitations :
 Ambient : -30 to +80°C standard
 Process : -40 to max on table
 Storage : -40 to +80°C

| PART NUMBER BREAKDOWN | | | THERMOWELL LENGTH 100 = 100MM STANDARD IF NOT REQUIRED LEAVE BLANK (OTHER LENGTHS, THREADS AND FLANGES ARE AVAILABLE. PLEASE CONTACT OUR SALES OFFICE). |
|--|---|---|---|
| T17 - WITH THERMOWELL T18 - WITHOUT THERMOWELL PREFIX WITH 'S' FOR STAINLESS STEEL SWITCHCASE | CAPILLARY CODE REFER TO TABLE ON OPPOSITE PAGE | STEM LENGTH 1 = 150MM STANDARD 2 = 250MM, 4 = 400MM 6 = 600MM. (150MM NOT AVAILABLE WITH 150M OR 200MM BULB LENGTH) | |
| (S) T 1 7 0 1 / 4 3 - 3 - 1 - 6 / P A 1 0 0 | | | |
| MICROSWITCH OPTIONS 01 = SINGLE SWITCH - STANDARD 02 = DUAL SWITCHES 03 = USE 01 04 = USE 02 05 = SINGLE FOR Exia 06 = DUAL FOR Exia 09* = MANUAL AND AUTO (RESET RISING) 0A* = MANUAL AND AUTO (RESET FALLING) 0C* = MANUAL (RESET RISING) 0D* = MANUAL (RESET FALLING) | CAPILLARY LENGTH 2 METRES MINIMUM 10 METRES MAXIMUM SLIDING GLAND THREAD 3 = 1/2" BSP.P 6 = 1/2" NPT | THERMOWELL CONN. (STANDARD) PA = 1/2" BSP.P PB = 1/2" NPT PC = 3/8" BSP.P PD = 3/4" BSP.P PE = 3/4" NPT PF = 1" BSP.P PG = 1" NPT THERMOWELL CONN. (HIGH PRESSURE) HA = 1/2" BSP.P HB = 1/2" NPT HC = 3/8" BSP.P HD = 3/4" BSP.P HE = 3/4" NPT HF = 1" BSP.P HG = 1" NPT | |
| *Change 0 to E for Exia certification | | | |

Thermowell and stem material :
316 stainless steel
Max working pressure :
35 Bar - standard
420 Bar - high pressure
Electrical connections
M20 x 1.5 ISO female standard

Thermowells can be provided flanged or screwed to suit the application. All exotic metals can be catered for. Material certificates and wake frequency vibration analysis calculations can be provided.

Suffix "F" for M25 X 1.5 ISO Female or "C" for 1/2" NPT female

DIMENSIONS IN MILLIMETRES

TYPICAL ARRANGEMENT DRAWING FOR REFERENCE ONLY

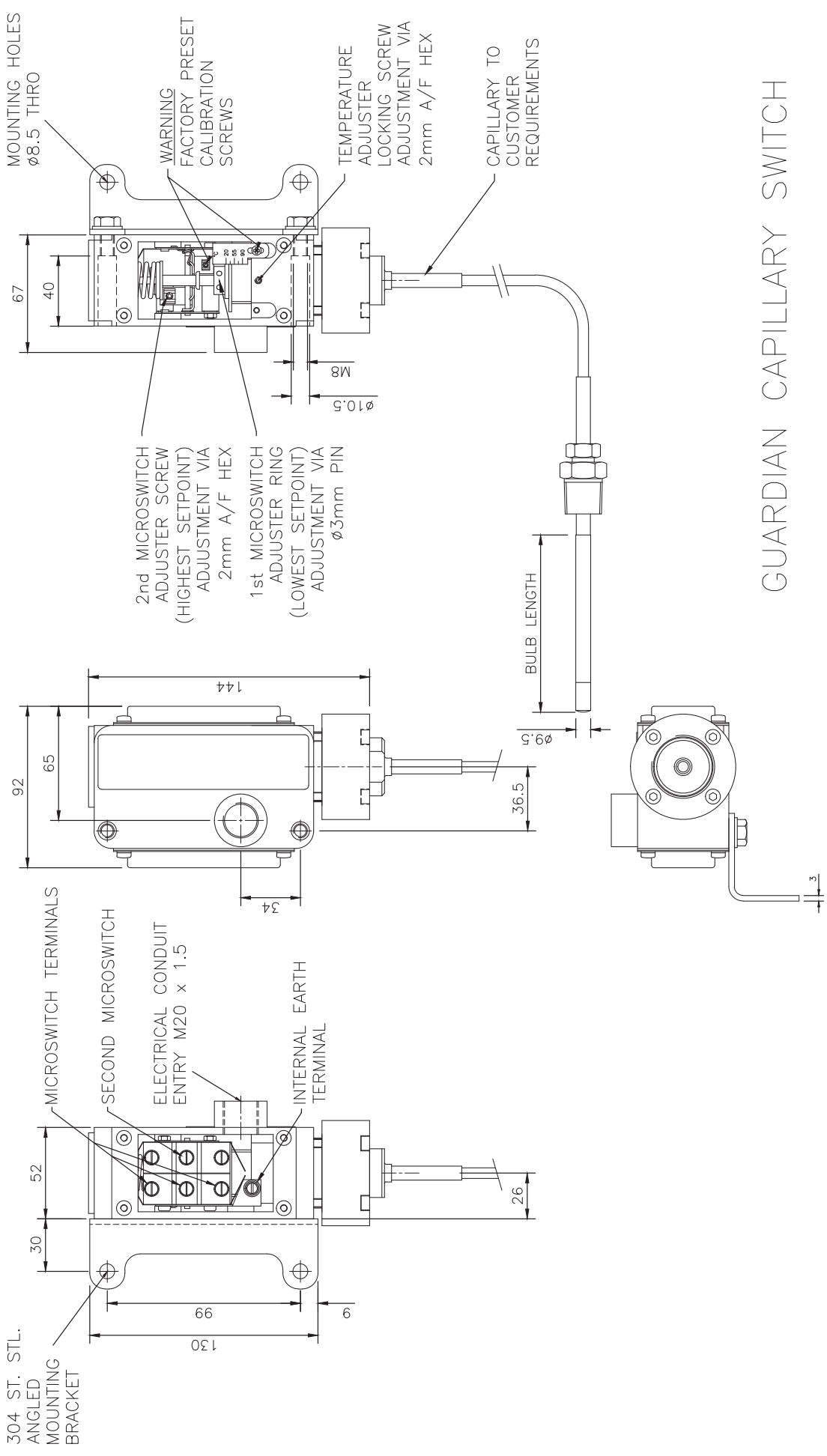

GUARDIAN CAPILLARY SWITCH

GUARDIAN INDUSTRIAL & ATEX SWITCHES

INTRODUCTION

The Guardian pressure, differential pressure, temperature, level and flow switches are a part of our extensive range of specialist process sensors. They utilise the expertise gained from over 50 years experience of designing and manufacturing control devices for industrial, marine and hazardous area applications.

These switches are constructed with either a robust aluminium or stainless steel enclosure. The aluminium casting is black anodised and supplied with 316 stainless steel covers. The stainless steel case is a natural finish. Covers are gasketed and sealed to achieve an environmental seal to IP66 & IP67 standards. The internals utilise a unique mechanism designed by the engineers at PYROPRESS to produce a wide range, low switching differential and excellent repeatability. This combined with a variety of microswitches, mountings and sensor options has produced a switch range suitable for all weatherproof and intrinsically safe applications.

CALIBRATION

The design features a simple form of calibration adjustment against a scale plate. This allows users to either order units with a specific setting, or stock a mid range setting and then calibrate to suit the application. Calibration is performed on the opposite side of the switch to the electrical connections, and can be set safely with the switch supply live. On removal of the adjustment cover a small grub screw can be loosened allowing the adjusting ring to be turned with a small Tommy bar or Allen key. The setting is read from the centre of the red indicating ring against the calibrated scale plate.

Calibration procedures for dual microswitches and adjustable switching differential switches are detailed on the operating and maintenance instructions supplied with each switch.

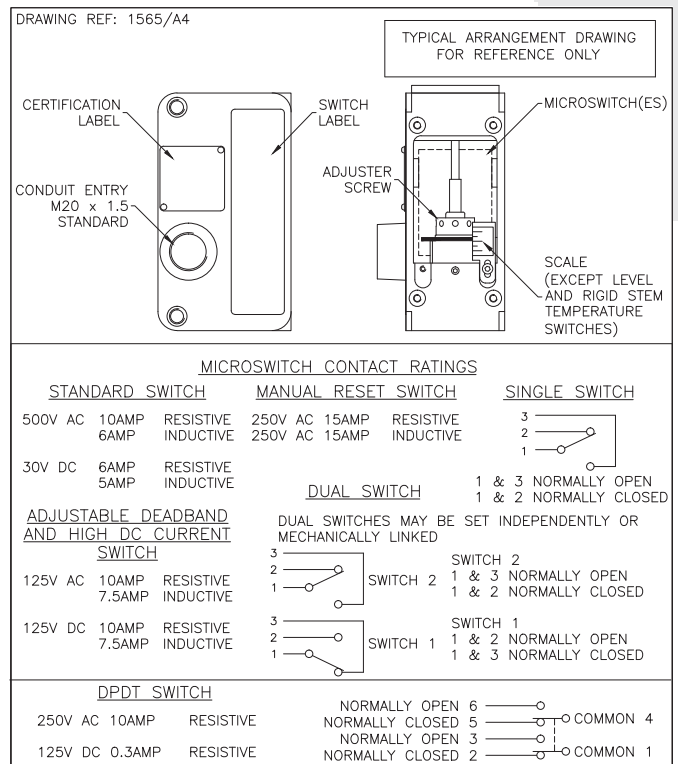

TECHNICAL SPECIFICATION

Switchcase and covers: 316 stainless steel switchcase with 316 stainless steel covers or black anodised aluminium switchcase and 316 stainless steel covers. Optional 304 stainless steel mounting bracket.

Microswitch: SPCO/SPDT. Options include single or twin switch assemblies for simultaneous or separately adjustable set points, adjustable switching differential, manual reset and noble metal contacts for use on intrinsically safe circuits.

Microswitch rating

| | |
|------------------------------|---|
| Standard microswitch | : 6 Amps @ 480 V.AC : 10 Amps @ 250 V.AC & 125 V.AC : 5 Amps @ 30 V.DC & 0.05 Amps @ 125 V.DC |
| Adjustable deadband and high | : 1.5 Amps @ 250 V.AC & DC |
| Current DC switching | : 7.5 Amps @ 125 V.AC & DC |

Electrical Connections: Screwed terminals direct onto microswitch, suitable for cable up to 2.5 mm². (Manual reset microswitch is supplied with 6BA solder tags).

Electrical Conduit Entry: M20 x 1.5 straight entry. Adaptors are available.

Environmental Protection: Switches have been tested and certified by an external test house to IP66 in accordance with BS EN 60529 : 1992. In addition further internal tests confirm that the switchcase meets the requirements of IP67.

Vibration and shock parameters: Switches were subjected to Lloyds Register Type Approval System Test Specification No.1 Clause 12 or 13 Vibration Test 1 or 2 (refer to sales for exact specifications) and shock tested to BS EN 60068-2-27 : 1987.

Temperature Limitations: Pressure, Vacuum and Differential Pressure.

Process: Diaphragm actuated (unless otherwise stated) -30 to +110°C (Nitrile) or -20 to +150°C (Viton). Piston actuated -30 to +120°C (Nitrile), or -20 to +150°C (Viton) or -50 to +150°C (PTFE) -30 to 125°C (EPDM)

Ambient: -25 to +80 Deg.C.

Storage: -25 to +80°C. (For temp, level and flow refer to specific pages).

Certification: All switches are CE certified and marked in accordance with the following EU directives. Industrial : 2014/35/EU (Low Voltage Directive).

Exia: ATEX 2014/34/EU coded CE Ex II1G Exia IIC. CAT 1 (Zone 0) areas. Special conditions for safe use. (Category 1, Zone 0) Aluminium may only be used when the ignition hazardous assessment shows that there is not risk of ignition from incensive, impact or abrasion sparks.

ABOUT PYROPRESS

Our products are designed to work in demanding and hazardous environments which require fast and cost effective solutions in instrumentation and control.

Pyropress control sensors provide safe and reliable electrical switching of alarm or control circuits in response to changes in temperature, pressure, differential pressure, vacuum, fluid, flow and level conditions.

QUALITY

To support the design of state of the art products the company has invested heavily in the latest CNC technology.

We are able to produce our own components to a high degree of accuracy assuring a reliable and consistent quality product.

<https://fluidic-ltd.co.uk/>

<https://fluidic-ltd.co.uk/>