

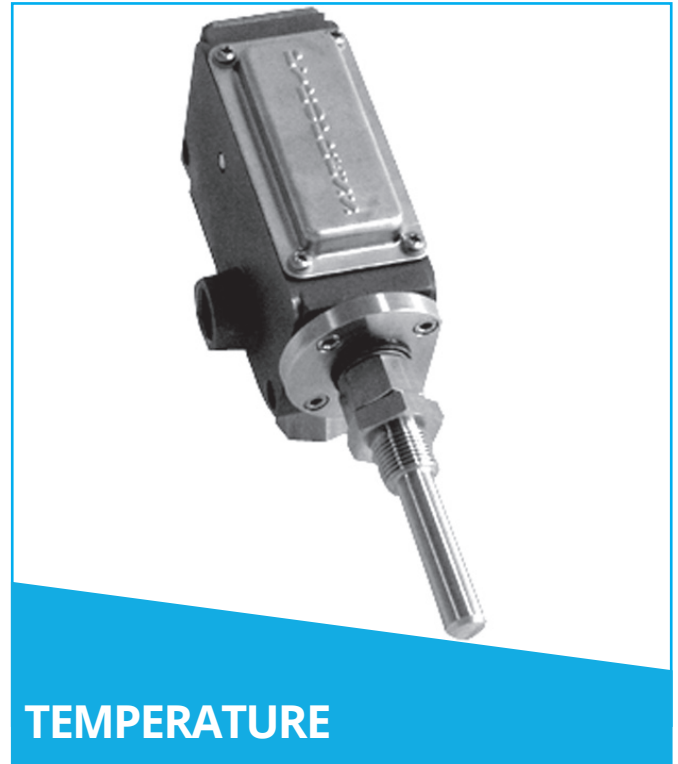

GUARDIAN LOW - MEDIUM - HIGH TEMPERATURE

T1100 & T1200 GUARDIAN INDUSTRIAL & ATEX CERTIFIED Exia TEMPERATURE SWITCH

The standard range represents the basic models to cover temperature applications spanning -10 to +240°C. The T1100 is supplied fitted with a threaded thermowell, the T1200 has no thermowell but is supplied with a threaded stem. Dual microswitch options are available for alarm and shutdown applications.



TEMPERATURE

FEATURES

- ✓ 316 stainless steel or black anodised aluminium switchcase.
- ✓ IP66/IP67 certified housing.
- ✓ SIL2 - IEC61508 proven reliability.
- ✓ Internal adjustment scale.
- ✓ Temperature Settings from -10 to +240°C.
- ✓ Single or dual microswitch option.
- ✓ Wetted parts NACE MR-01-75 option.
- ✓ ATEX Certified Option
CE II1G Ex ia IIC
T6 Tamb -50 to +78°C
T5 Tamb -50 to +93°C
T4 Tamb -50 to +128°C

ADJUSTMENT RANGE (°C)	MAXIMUM TEMPERATURE (°C)	DEADBAND (°C)	TEMPERATURE CODE	THERMOWELL "U" DIMENSIONS IN MM
-10 TO +40	100	<10	L1	38, 45, 50, 60*, 75*, 100, 125, 150, 175, 200, 225, 250, 300, 350, 400, 600, 660, 800, 1000 & 1200 *STANDARD LENGTHS
0 TO +50	100	<10	L2	
25 TO 75	125	<10	M1	
50 TO 100	150	<10	M2	
75 TO 125	175	<10	M3	
100 TO 150	200	<10	M4	
125 TO 175	200	<10	M5	
150 TO 200	250	<10	H1	
175 TO 225	280	<10	H2	
200 TO 240	280	<10	H3	

Repeatability : +/-1.5% of range (at operating temperature up to 40°C)
Calibration rate : 2°C per minute rate of charge.

Temperature Limitations :
 Ambient : -10 to +80°C standard
 Process : -10 to max on table**
 Storage : -10 to +80°C**
 ** -50°C is available as an option

PART NUMBER BREAKDOWN			THERMOWELL / STEM
T11 - WITH THERMOWELL T12 - WITHOUT THERMOWELL	"U" DIMENSION WITH THERMOWELL	P = WITH THERMOWELL S = WITHOUT THERMOWELL	1 = 316 ST. ST. 4 = HIGH PRESS. 0 = FLANGE OR SPECIAL THERMOWELL 8 = SLIDING GLAND
PREFIX WITH 'S' FOR STAINLESS STEEL CASE			
<div style="font-size: 2em; font-weight: bold; letter-spacing: 0.5em;">(S) T 1 1 0 1 / 0 6 0 M 2 / P A 1 X</div>			
MICROSWITCH OPTIONS 01 = SINGLE SWITCH 02 = DUAL SWITCHES 03 = USE 01 04 = USE 02 05 = SINGLE - FOR Exia 06 = DUAL FOR Exia 09* = MANUAL AND AUTO (RESET RISING) 0A* = MANUAL AND AUTO (RESET FALLING) 0C* = MANUAL (RESET RISING) 0D* = MANUAL (RESET FALLING)	TEMPERATURE ELEMENT CODE REFER TO TABLE ON OPPOSITE PAGE	THERMOWELL / STEM THREAD A = 1/2" BSP.P F = 1" BSP.P B = 1/2" NPT G = 1" NPT C = 3/8" BSP.P K = 1/2" BSP.T D = 3/4" BSP.P E = 3/4" NPT 0 = FLANGE OR SPECIAL THERMOWELL	
*Change 0 to E for Exia certification			

SPECIFICATION

Thermowell and stem material :
 316 Stainless steel
 Max working pressure :
 35 Bar - standard
 420 Bar - high pressure

Thermowells can be provided flanged or screwed to suit the application. All exotic metals can be catered for. Material certificates and wake frequency vibration analysis calculations can be provided.

Electrical connection
 M20 x 1.5 ISO female standard
 Suffix "F" for M25 x 1.5 ISO female or "C" for 1/2" NPT female

DIMENSIONS IN MILLIMETRES

TYPICAL ARRANGEMENT DRAWING FOR REFERENCE ONLY

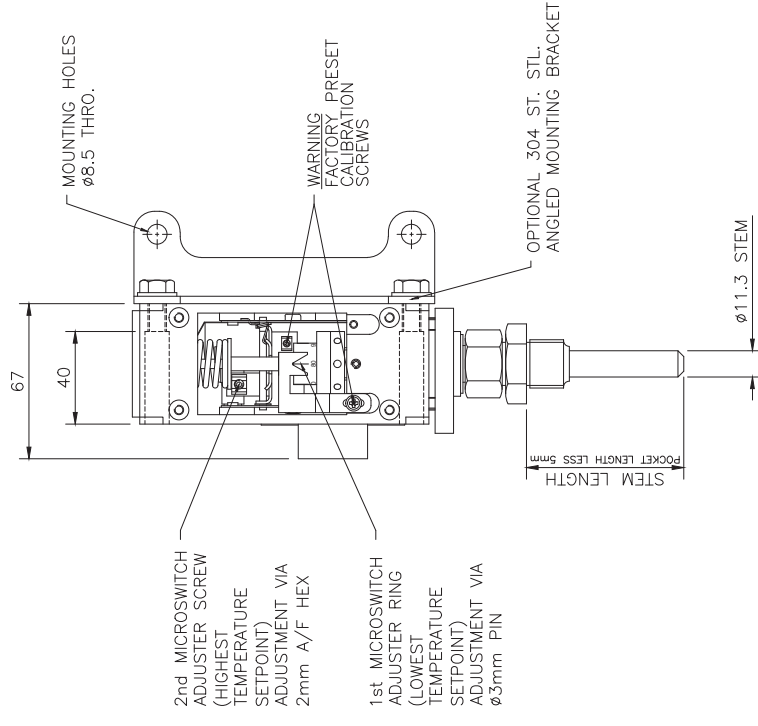
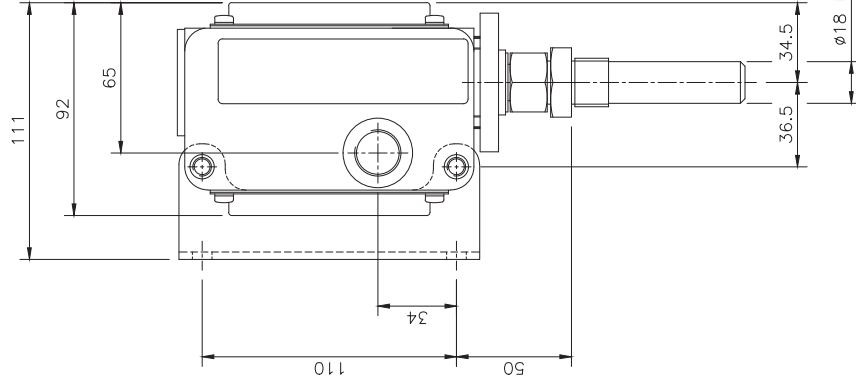
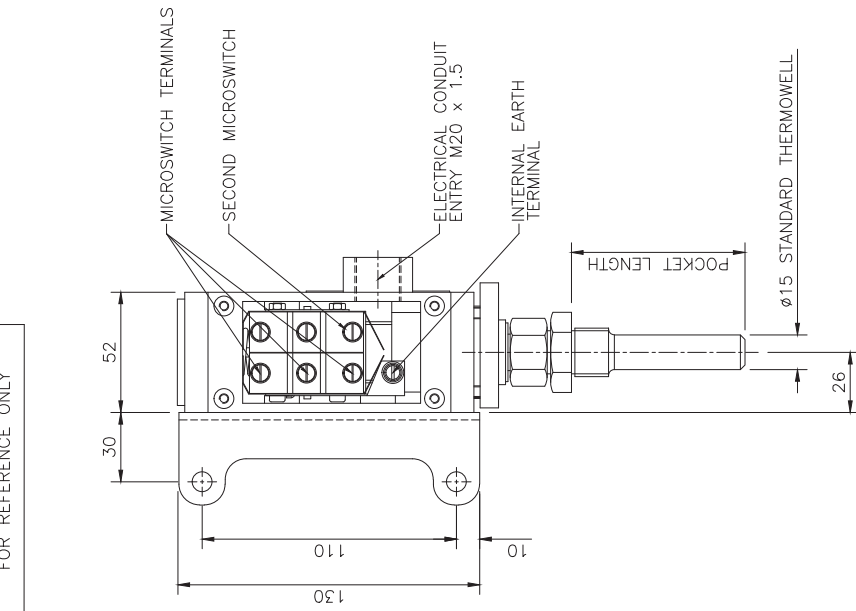

AVAILABLE POCKET & STEM HEAD THREADS
3/8" BSP
1/2" BSP
1/2" NPT
3/4" NPT
1" NPT

STANDARD THREADS

GUARDIAN TEMPERATURE SWITCH

GUARDIAN INDUSTRIAL & ATEX SWITCHES

INTRODUCTION

The Guardian pressure, differential pressure, temperature, level and flow switches are a part of our extensive range of specialist process sensors. They utilise the expertise gained from over 50 years experience of designing and manufacturing control devices for industrial, marine and hazardous area applications.

These switches are constructed with either a robust aluminium or stainless steel enclosure. The aluminium casting is black anodised and supplied with 316 stainless steel covers. The stainless steel case is a natural finish. Covers are gasketed and sealed to achieve an environmental seal to IP66 & IP67 standards. The internals utilise a unique mechanism designed by the engineers at PYROPRESS to produce a wide range, low switching differential and excellent repeatability. This combined with a variety of microswitches, mountings and sensor options has produced a switch range suitable for all weatherproof and intrinsically safe applications.

CALIBRATION

The design features a simple form of calibration adjustment against a scale plate. This allows users to either order units with a specific setting, or stock a mid range setting and then calibrate to suit the application. Calibration is performed on the opposite side of the switch to the electrical connections, and can be set safely with the switch supply live. On removal of the adjustment cover a small grub screw can be loosened allowing the adjusting ring to be turned with a small Tommy bar or Allen key. The setting is read from the centre of the red indicating ring against the calibrated scale plate.

Calibration procedures for dual microswitches and adjustable switching differential switches are detailed on the operating and maintenance instructions supplied with each switch.

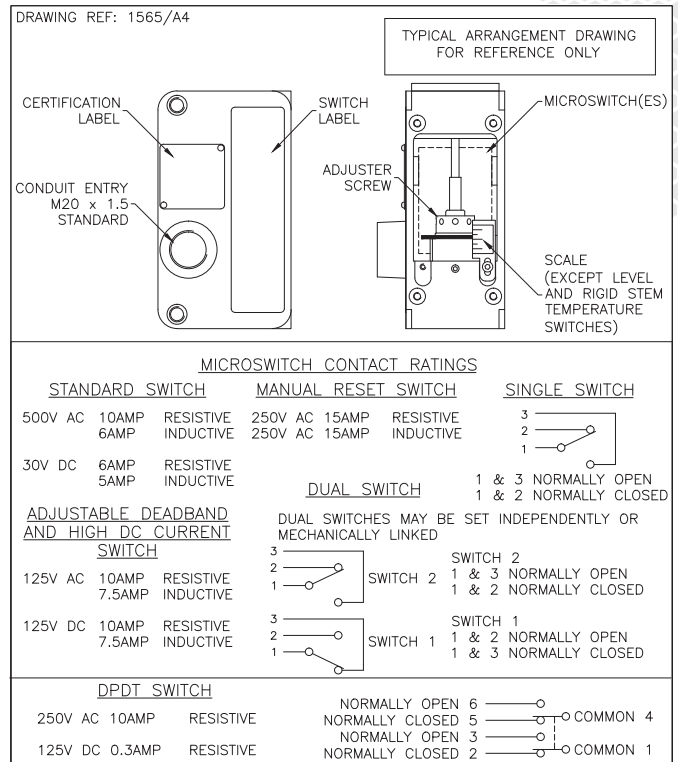

TECHNICAL SPECIFICATION

Switchcase and covers: 316 stainless steel switchcase with 316 stainless steel covers or black anodised aluminium switchcase and 316 stainless steel covers. Optional 304 stainless steel mounting bracket.

Microswitch: SPCO/SPDT. Options include single or twin switch assemblies for simultaneous or separately adjustable set points, adjustable switching differential, manual reset and noble metal contacts for use on intrinsically safe circuits.

Microswitch rating

Standard microswitch	: 6 Amps @ 480 V.AC : 10 Amps @ 250 V.AC & 125 V.AC : 5 Amps @ 30 V.DC & 0.05 Amps @ 125 V.DC
Adjustable deadband and high	: 1.5 Amps @ 250 V.AC & DC
Current DC switching	: 7.5 Amps @ 125 V.AC & DC

Electrical Connections: Screwed terminals direct onto microswitch, suitable for cable up to 2.5 mm². (Manual reset microswitch is supplied with 6BA solder tags).

Electrical Conduit Entry: M20 x 1.5 straight entry. Adaptors are available.

Environmental Protection: Switches have been tested and certified by an external test house to IP66 in accordance with BS EN 60529 : 1992. In addition further internal tests confirm that the switchcase meets the requirements of IP67.

Vibration and shock parameters: Switches were subjected to Lloyds Register Type Approval System Test Specification No.1 Clause 12 or 13 Vibration Test 1 or 2 (refer to sales for exact specifications) and shock tested to BS EN 60068-2-27 : 1987.

Temperature Limitations: Pressure, Vacuum and Differential Pressure.

Process: Diaphragm actuated (unless otherwise stated) -30 to +100°C (Nitrile) or -20 to +150°C (Viton). Piston actuated -30 to +100°C (Nitrile), or -20 to +150°C (Viton) or -50 to +150°C (PTFE) -30 to 125°C (EPDM)

Ambient: -25 to +80 Deg.C.

Storage: -25 to +80°C. (For temp, level and flow refer to specific pages).

Certification: All switches are CE certified and marked in accordance with the following EU directives. Industrial : 2014/35/EU (Low Voltage Directive).

Exia: ATEX 2014/34/EU coded CE Ex II1G Exia IIC. CAT 1 (Zone 0) areas. Special conditions for safe use. (Category 1, Zone 0) Aluminium may only be used when the ignition hazardous assessment shows that there is no risk of ignition from incensive, impact or abrasion sparks.

ABOUT PYROPRESS

Our products are designed to work in demanding and hazardous environments which require fast and cost effective solutions in instrumentation and control.

Pyropress control sensors provide safe and reliable electrical switching of alarm or control circuits in response to changes in temperature, pressure, differential pressure, vacuum, fluid, flow and level conditions.

QUALITY

To support the design of state of the art products the company has invested heavily in the latest CNC technology.

We are able to produce our own components to a high degree of accuracy assuring a reliable and consistent quality product.

<https://fluidic-ltd.co.uk/>

<https://fluidic-ltd.co.uk/>