

## MFS-SS - Self-Averaging stainless steel Flow Sensor for the measurement of velocity or flow in air and other gases

## MFS-SS

Data sheet : Md-1303gb\_030722

- Self-Averaging stainless steel construction
- For circular and rectangular ducts
- Available in lengths from 100 to 1000mm
- High precision measurement
- High differential pressure
- Low pressure drop

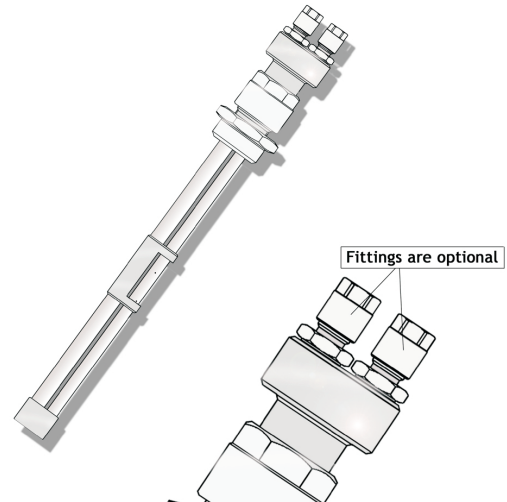

### Description

Micatrone's flow sensor MFS-SS, has been developed to meet the great demand for accurate air flow measurement in all types of air-handling systems.

The MFS-SS is based on the principle of averaging the velocity profile over the height or the diameter of the duct.

The MFS averages the velocity profile by measuring the total pressure ( $P+$ ) which consists of the dynamic and static pressure, as well as an amplified lower pressure ( $P-$ ).

These form together a differential pressure which is proportional to the flow.

The differential pressure is 2.0 times higher than acquired by Prandtl measurement.

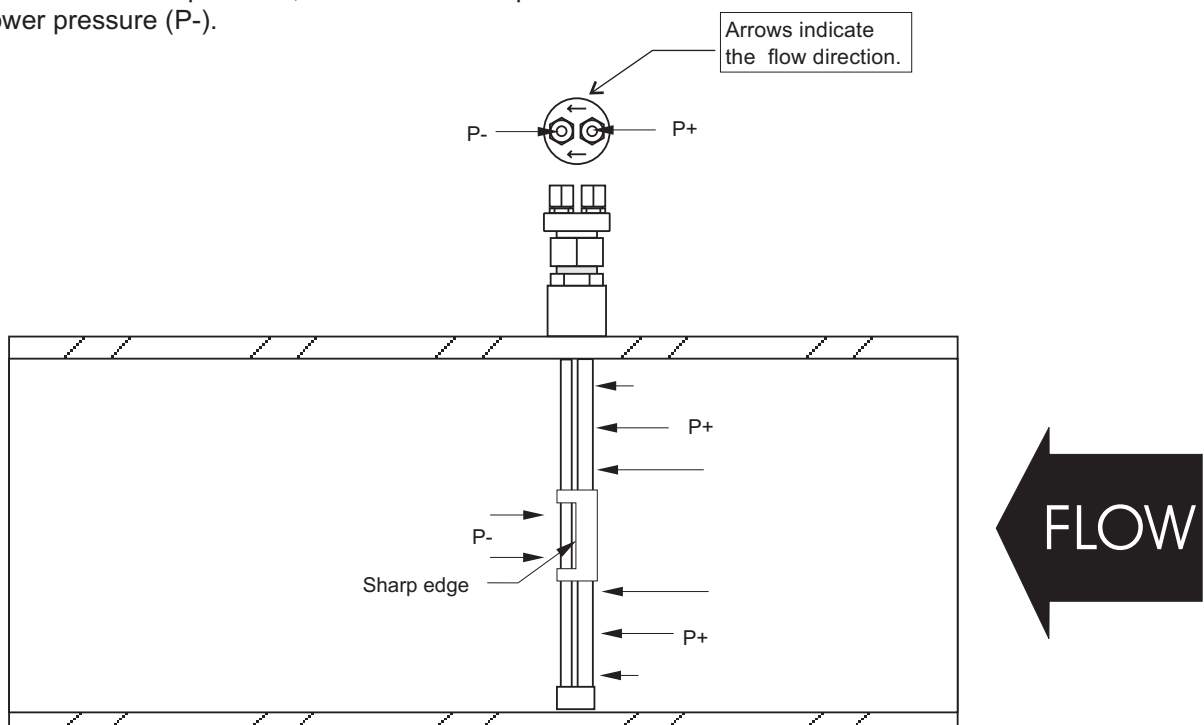

## Flow constant

The MFS-SS is to be installed in a circular or rectangular duct. Length specified when ordered. The average value of the air flow over the whole length of the sensor results in a pressure difference, out of which the total air flow or air velocity may be calculated.

These formulas are valid for air at 20 °C and 1013 mbar.

$$v = K_m \times \sqrt{\Delta p} \text{ m/s}$$

$$Q = A \times K_m \times \sqrt{\Delta p} \text{ m}^3/\text{s}$$

Where the included variables represents:

- v = velocity in m/s
- $K_m$  = the constant of the sensor
- $\Delta p$  = the pressure difference in Pa
- A = the area of the duct in  $\text{m}^2$
- $\rho$  = The density of the air in  $\text{kg}/\text{m}^3$
- B = actual barometric pressure in mbar
- t = the actual temperature in °C

With a different temperature or barometric pressure of the air, the values must be calculated for the change in the density of the air according to the formulas below:

$$\rho = 1,293 \times \frac{B}{1013} \times \frac{273}{273 + t} \text{ kg}/\text{m}^3$$

$$v = K_m \times \sqrt{\Delta p \times \frac{12}{\rho}} \text{ m/s}$$

$$Q = A \times K_m \times \sqrt{\Delta p \times \frac{12}{\rho}} \text{ m}^3/\text{s}$$

The constant of the sensor ( $K_m$ ) is found on a small tag, which is attached to the sensor.

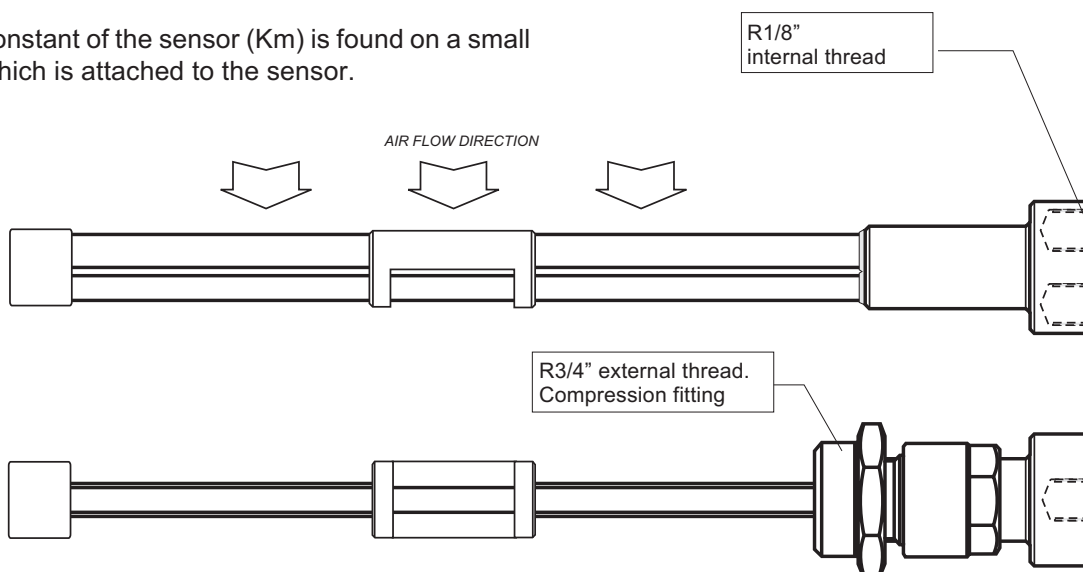

## Error in measurement

The error in measurement depends partly on the sensor and partly on the flow profile in the duct. With a proper flow profile, the maximum error in the measurement is normally  $\pm 3\%$ .

## Maintenance

Normally the sensor does not need any maintenance. If the air is very polluted, it is appropriate to dismount the sensor once a year and to clean it off with compressed air.

No part of the sensor will get damaged during normal cleaning. It is allowed to use compressed air both on the outer side of the sensor and through the pressure taps. Make sure that the sensor is not connected to the transmitter during cleaning.

## Installation

To achieve a good result, the sensor should be installed at least 7 times its own length from a 90° bend or any other source of disturbance. For advice in other kinds of installation, contact Micatrone.

Adjust the position of the sensor to meet the flow direction.

Connect the sensor to a flow transmitter MicaFlex MF-FD or MF-PFT with a rigid 8/6 mm HT plastic tube or Swagelock connections, either  $\varnothing 6$  mm or  $\varnothing 1/4$  inch. The measured pressure will be converted to a flow linear output signal in the Micaflex.

**AB Micatrone**  
Dalvägen 8  
SE-169 56 SOLNA  
SWEDEN

**Telephone:** +46 8 470 25 00  
**Fax:** +46 8 83 27 80  
**Internet:** [www.micatrone.se](http://www.micatrone.se)  
**E-mail:** [info@micatrone.se](mailto:info@micatrone.se)

# Flange mounting

# Threaded connector

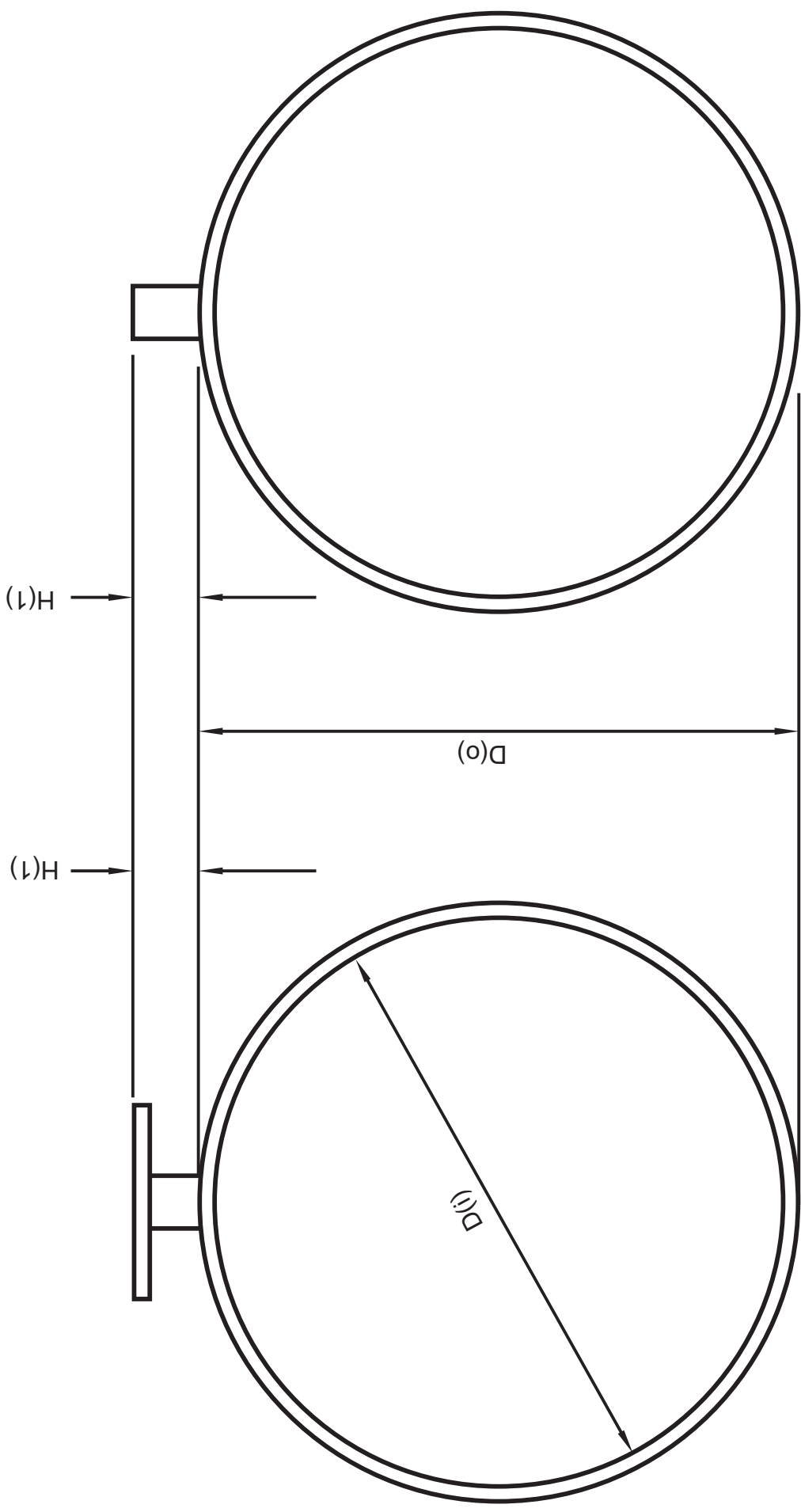

$D(o) =$  \_\_\_\_\_ mm

$D(i) =$  \_\_\_\_\_ mm

$H(1) =$  \_\_\_\_\_ mm

Mounting (X) :

FLANGE MOUNTING

THREADED CONNECTOR

# micatrone®

CUSTOMER ORDERING SPECIFICATION

© Micatrone # M-3511\_011220