

February 2017

Description

Part of the Moore Industries **FS FUNCTIONAL SAFETY SERIES**, the **exida®** SIL 2 and SIL 3 certified STA Safety Trip Alarm performs as a logic solver and acts on potentially hazardous process conditions; warns of unwanted process conditions; provides emergency shutdown; or provides on/off control in Safety Instrumented Systems (SIS) and traditional alarm trip applications.

The 4-wire (line/mains-powered) STA models accept a signal input from transmitters, temperature sensors and a wide array of other monitoring and control instruments (see Figure 1) including:

- **Current and Voltage Signals**
- **Temperature (RTD and T/C) Sensor Inputs**
- **Resistance and Potentiometer Devices**
- **Direct Millivolt Sources**

Dual Process Alarms, One Fault Alarm

Two configurable process alarms trip when a monitored process variable falls outside of user-set high and/or low limits. Alarm #3 is set as an input/instrument fault alarm (see Page 2).

Figure 1. Dual process alarms with input/instrument fault alarm.

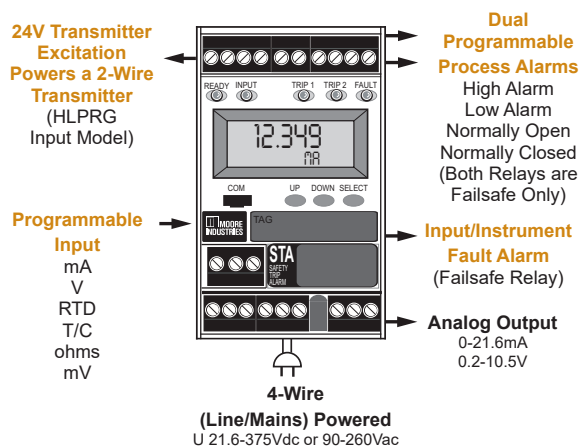

Certifications

- exida Certified**
IEC 61508:2010 Parts 1, 2 and 3
Functional Safety of Electrical/Electronic/Programmable Electronic Safety-Related Systems
- CE Conformant** - EMC Directive 2014/30/EU EN61326;
Low Voltage Directive (LVD) 2014/35/EU EN 61010-1
- Canadian International (Canada & US)**
General/Ordinary Locations
- Non-Incendive Equipment**
Class I, Division 2, Groups A, B, C, D



The STA features a metal, RFI/EMI resistant housing with display that snaps onto standard DIN-style rails.

Features

- **exida certified IEC 61508:2010.** For systematic integrity up to SIL 3 and for random integrity up to SIL 2. This means that an STA is approved for single use in Safety Instrumented Systems (SIS) up to SIL 2 and in redundant architectures (1oo2, 2oo3, etc.) up to SIL 3.
- **Comprehensive FMEDA certified safety data.** Upon request, **exida**-certified FMEDA (Failure Modes, Effects and Diagnostics Analysis) data is provided to be used by a competent functional safety practitioner to determine the STA's applicability as a logic solver in specific safety-related applications.
- **20-bit input resolution with long-term stability.** Delivers industry-best digital accuracy with up to 5 years between scheduled calibrations.
- **Site-programmable with password protection.** Front panel pushbuttons with menu-guided configuration deliver confident and secure set up.
- **Large 5-digit process and status readout.** Backlit display shows menu prompts during configuration and, when in operation, shows the process variable, the output or toggles between the two in selectable engineering units.
- **Isolated and RFI/EMI protection.** Delivers superior protection against the effects of ground loops and plant noise.
- **Combined alarm trip and transmitter.** The analog output (-AO) option reduces costs and installation time when both alarm and transmitter functions are needed at the same location.

SIL 2 and SIL 3 Capable Programmable Current/Voltage and RTD/Thermocouple Safety Trip Alarms

Dual Safety Trip Process Alarms with One Input/Instrument Fault Alarm

Dual High or Low Limit Process Alarms—The STA monitors a temperature, pressure, level, flow, position or status variable. If the input exceeds a user-selectable high or low limit, independent dual alarm outputs warn of unwanted process conditions (Figure 2), provide emergency shutdown or provide on/off control (Figure 3).

Input/Instrument Fault Alarm—The STA checks its own operation and configuration upon start up, and then continuously monitors its status during operation. It also continuously monitors its input signal.

Alarm #3 is set as a fault alarm that will trip if Internal-Diagnosed faults or external faults, such as loss of sensor or “bad quality input”, occur. Unit faults are always latching but input faults can be configured to latch or not. This alarm will trip without affecting the other relays being used to monitor the process, and can be used to warn of a failure without tripping more critical process alarms or shutting down the process.

Figure 2. High and/or low limit alarms, with a selectable deadband to reduce false alarms, can be used to warn of unwanted process conditions or to provide emergency shutdown.

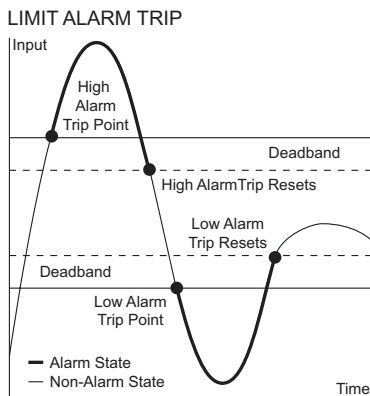

Total Sensor Diagnostics for RTD Inputs

Our STA Alarm Trip (TPRG input model) performs continuous sensor diagnostics. This industry-first and patented Moore Industries feature saves you time and money by letting you know when a problem occurs, and its type and location. If the RTD input breaks, the fault alarm is tripped. A plain-English error message on the display indicates exactly which RTD wire has broken. Specific error messages eliminate the work of removing the sensor or checking all lead wires to diagnose a problem.

Figure 3. The STA can be used as a simple on/off controller such as those required in level applications (pump/valve control) when filling, emptying or preventing overflow of a container or tank.

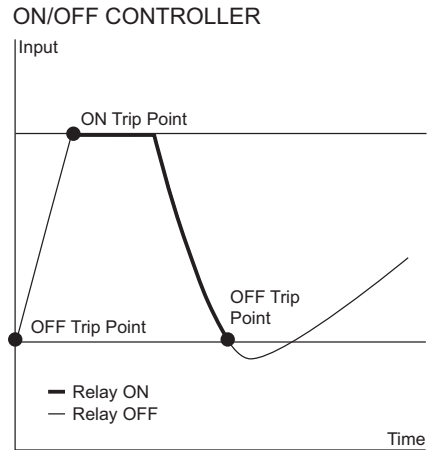

STA Performs as a Single Loop Logic Solver in Safety Instrumented Systems (SIS)*

A Safety Instrumented System (SIS) is defined as an instrumented system used to implement one or more Safety Instrumented Functions (SIF). A SIS is composed of any combination of sensors, logic solvers (such as the STA) and final elements.

Examples of SIF applications include:

- Shutdown fuel supply to a furnace
- Open a valve to relieve excess pressure
- Add coolant to arrest exothermic runaway
- Close a feed valve to prevent tank overflow
- Initiate release of a fire suppressant
- Initiate an evacuation alarm

Typical examples of the STA used in Safety Instrumented System architectures include High Integrity, High Availability, 1oo2 Redundant/Voting and Analog Output

* The user of this data is responsible for determining it's applicability of the subject device used in any particular environment.

SIL 2 and SIL 3 Capable Programmable Current/Voltage and RTD/Thermocouple Safety Trip Alarms

Typical examples of the STA in Safety Instrumented Systems (SIS) include:

Figure 4. The STA in a High Integrity Architecture (SIL 2 capable).

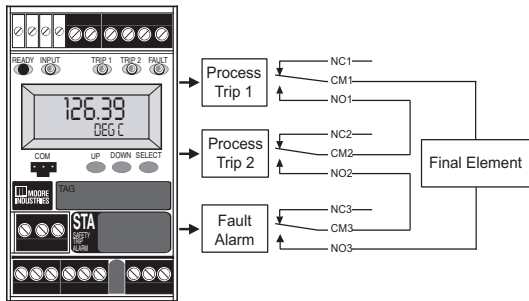

High Integrity Architecture—This configuration offers the highest trip integrity in a non-redundant application (Figure 4). Since all three relays are wired in series, any trip alarm or fault alarm will trip the final element or logic solver.

Figure 5. The STA in a High Availability Architecture (SIL 2 capable).

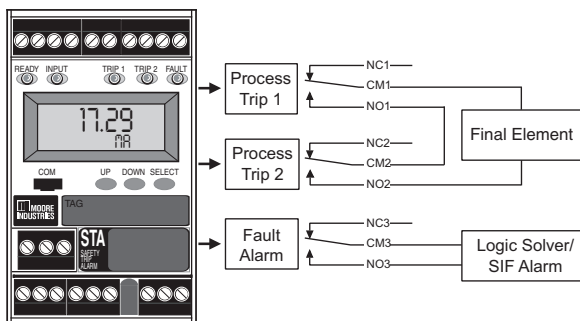

High Availability Architecture—In this configuration, the Safety Trip Alarm provides higher process or system availability (Figure 5). The fault alarm is wired separately to inform a safety system that there is a fault alarm and that this component's ability to carry out its portion of the Safety Instrumented Function cannot be performed. This configuration would be used in applications where it is desirable to keep the process running should a fault occur because of a bad input or instrument fault. The output process trip relays are connected in a 1oo2 scheme to trip, providing security against a single relay failure. However, should the fault relay become active, the fault should be removed before the Safety Trip Alarm can provide proper safety coverage.

1oo2 Redundant Architecture—In this architecture, every component appears twice, and may be applicable for use in SIS systems up to SIL 3 (Figure 6). Advantages are improved reliability of trip action

and reduced vulnerability to a single failure compared to a 1oo1 architecture. The logic in this configuration is an 'OR' statement for the safety function; if either sensor input reaches a trip condition or a fault relay is activated, the loop or function will reach a tripped state.

Figure 6. The STA in a 1oo2 Redundant/Voting Architecture is Applicable for Use in SIS Systems Up to SIL 3.

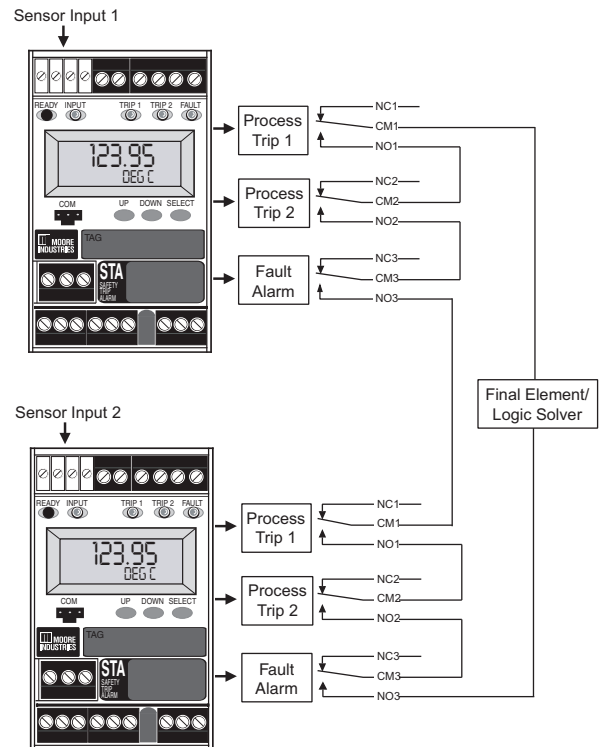
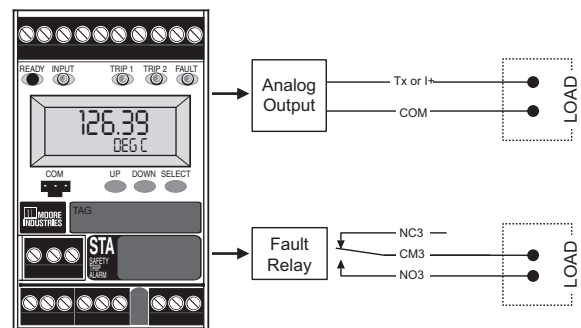

Figure 7. The STA with Analog Output (AO) in the Safety Path



Analog Output in the Safety Path—When the Analog Output is used in the safety path, the fault alarm must also be monitored to detect STA failures. In Figure 7 above, the fault alarm is wired separately in a high availability architecture. The fault alarm can also be wired in series with the Analog Output to provide a high integrity architecture.

SIL 2 and SIL 3 Capable Programmable Current/Voltage and RTD/Thermocouple Safety Trip Alarms

Site-Programmable with Secure Password Protection

Selectable operating parameter functions:

- Security password protection on/off (via internal jumper) and password creation
- Start up delay (0-120 seconds)
- Input type, measurement range and out of range settings
- Input and output trimming
- High or low process alarm(s) with trip points
- Normally open or normally closed alarm relays (latching/non-latching selectable for process alarms; and input faults (unit faults are fixed as latching)
- Alarm deadband and alarm time delay
- Display parameters (scale, engineering units and set number of digits after the decimal point)
- Analog output range
- On input failure, analog output can be set to drive upscale or downscale or fail to last value
- Analog signal output damping (0-30 seconds)

Configuration and Input Validation make it impossible to program the STA with an invalid configuration.

Quick Ranging Calibration

Using the front panel pushbuttons, precise zero and span settings can be made in seconds. Just select the zero and span values, and the push of a button locks the values into the alarm trip's memory.

Intelligent PC Configuration Software

With the STA, you may either set up the instrument using the external push button controls or use Moore Industries' Intelligent PC Configuration software (Figure 8).

When using the software program, settings are downloaded to the instrument in the form of a Configuration File and stored in the instrument's memory. You can save a backup copy of the file on your PC hard drive or disk. The STA communicates with the PC through an RS-232 connection to the PC's serial port or optional USB Communications Cable.

Superior Reference Junction Compensation (RJC)

Uncompensated plastic terminals are very susceptible to ambient temperature changes that may result

Figure 8. In addition to push button configuration, the Configuration Software can be used to quickly program an STA from a single software window.

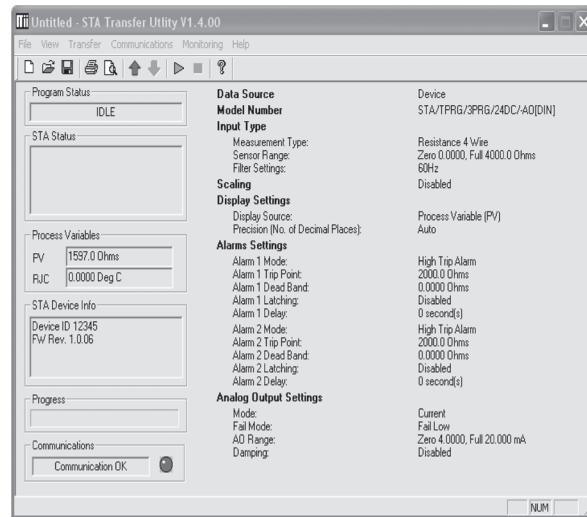

in readings that are "off" by several degrees. STA models that accept temperature inputs (TPRG input) feature metal terminals and advanced electronic compensation techniques that provide a stable measurement in fluctuating ambient temperature conditions.

Combination Alarm and Isolated Transmitter

When ordered with the Analog Output (-AO) option, the STA provides a proportional and isolated analog retransmission of the input signal that can be sent to remote monitoring/control devices like a DCS, PLC, PC, indicator or data recorder. All analog parameters can be selected using the STA pushbuttons. Upon input failure, the analog output can be user-set for upscale or downscale drive or fail to last value.

Trim to Specific Curve Segments

The STA can be trimmed with two data points within the selected zero and span measurement range. This allows a complete process range to be monitored while placing measurement emphasis on a critical segment of the range. This provides incredible precision over a limited portion of the span while measuring the remainder of the span with outstanding accuracy.

Powers a 2-Wire Transmitter

The STA (HLPRG: current/voltage input model) comes standard with 2-wire transmitter excitation that provides 24Vdc to power the loop. This saves the cost of specifying and installing an additional instrument power supply to power a 2-wire transmitter on the input loop.

SIL 2 and SIL 3 Capable Programmable Current/Voltage and RTD/Thermocouple Safety Trip Alarms

Specifications (HLPRG: mA and V Input Model)

Performance **Input Range:** Current Input 0-50mA (4mA minimum span); Voltage Input 0-11V (1V minimum)

Input Accuracy and Alarm Trip Repeatability: Current inputs, 2microamps (0.01% of 20mA span); Voltage inputs, 1mV (0.01% of maximum span)

Overall Accuracy: The overall accuracy of the unit is the combined input and output accuracies. It includes the combined effects of linearity, hysteresis, repeatability and adjustment resolution. It does not include ambient temperature effect.

Stability: Refer to Table 1

Dead Band: 11V or 50mA, maximum in Linear Mode; equivalent of maximum input range in user-set engineering units in Scaling/Custom Mode

Input to Output Trip Response Time: 256msec maximum from step change on input to alarm state change when alarm is set to trip at mid-point of step

Alarm Trip Delay: Programmable from 0-120 seconds (0-60 seconds for firmware versions 1.1.2 and earlier)*

Isolation: 500Vrms between case, input, output, and power

Dielectric Strength: 1966Vdc for 2 seconds, between case, input, output, and power

Power Supply: U range 21.6-375Vdc or 90-260Vac; *24DC range, 18-30Vdc; *UAC range, 90-260Vac;

Power Consumption: 5W maximum for Universal; 3.5W maximum for DC supply; 4W maximum for UAC supply

Power Supply Effect: ±0.002% of span per 1% line voltage change

Input Over-Range Protection: Current, ±100mA, maximum; Voltage, ±30Vdc, maximum

Input Impedance: Current, 20 ohms; Voltage, 1Mohm

TX Power Supply: 24Vdc, ±10% @ 24mA (regulated)

*Power Supply options no longer available for purchase.

Performance (continued) **Output Relays** Dual Process Relays and One Fault Relay (Relays are single-pole/double-throw SPDT, 1 form C, rated 3A@250Vac or 3A@30Vdc, 50/60Hz, non-inductive)

Performance of Analog Output (-AO Option) **Analog Output Option** **Output Accuracy:** Current, ±0.01% of maximum span (±2 microamps); Voltage, ±0.01% of max. span (±1mV)

Input to Analog Output Response Time: 256msec for the output to change 10% to 90% of its scale for an input step change of 0 to 100%

Analog Output Step Response Time: 100msec maximum

Analog Output Ripple (up to 120Hz): 50mV peak-to-peak maximum on voltage output; 10mV peak-to-peak measured across a 250 ohm load resistor for current output

Analog Output Range: Current Output 0-21.6mA, Minimum Span 4mA; Voltage Output -0.2-10.5V; Minimum Span 1V

Analog Output Current Limiting:

Output	Failure Limits
0-20mA	0, 23.6mA
4-20mA	3.6, 23.6mA
X-20mA (0<X<4)	(90% of X), 23.6mA

Voltage output: Failure Limit: -0.50 -11.0V

Load Capability: Source mode (internal power supply), 0-1 kohms for current output; 2 kohms for voltage output; Sink Mode (External power Supply), 42Vdc Max

Load Effect (current outputs): ±0.01% of span from 0 to maximum load resistance on current output

Ambient Conditions Operating Range: -40°C to +85°C (-40°F to +185°F)
Relay Range: -40°C to +85°C (-40°F to +185°F)

Ambient Conditions (continued) **Storage Range:** -40°C to +85°C (-40°F to +185°F)

Ambient Temperature Effect: Current, 2 microamps/°C; Voltage, 1mV/°C; Output, ±0.009% of max. span/°C

Relative Humidity: 5-95%, non-condensing

RFI/EMI Protection: 20V/m@80-1000MHz, 1kHz AM, when tested to IEC61326

Noise Rejection: Common Mode, 100dB@50/60Hz Normal Mode, Current Input, 70dB typical @ 50mA_{p-p}@ 50/60Hz; Voltage Input, 70dB typical@1V_{p-p}@ 50/60Hz

Adjustments Front panel push-buttons for parameter configurations; Internal jumper and menu password protect parameter settings

Indicators **LCD:** 2x5 14-segment characters, backlit, alphanumeric readout accurate to the nearest digit. **Range:** -99999 to 99999; Decimal point can be user-set

LED Type: INPUT LED: Dual color LED indicates input failure
READY LED: Green LED indicates unit is operating properly
ALARM 1 and 2 LED: Dual color LED per relay indicates alarm status
FAULT LED: Green LED indicates unit is operating properly; Red LED indicates unit has fault or is latched.

Display Accuracy: ±1 digit; when scaling the display (or in custom mode), high input-to-display span ratios decrease display accuracy

Weight 513 g to 564 g (18.1 oz to 19.9 oz)

Table 1. Long-Term Stability (HLPRG Input Model)

Stability (% of maximum span)	Input to Analog Output (Years)			Input to Relay (Years)		
	1 yr	3 yrs	5 yrs	1 yr	3 yrs	5 yrs
Current Inputs	0.081	0.14	0.18	0.047	0.081	0.105
Voltage Outputs	0.093	0.16	0.21	0.066	0.114	0.147

SIL 2 and SIL 3 Capable Programmable Current/Voltage and RTD/Thermocouple Safety Trip Alarms

Specifications (TPRG: RTD, T/C, Ohm, mV and Potentiometer Input Model)

<p>Performance</p> <p>Input Accuracy and Alarm Trip Repeatability: Refer to Table 2</p> <p>Overall Accuracy: The overall accuracy of the unit is the combined input and output accuracies. It includes the combined effects of linearity, hysteresis, repeatability and adjustment resolution. It does not include ambient temperature effect. For T/C input, add the RJC error.</p> <p>Reference Junction Compensation Accuracy (T/C inputs only): ±0.45°C</p> <p>Stability: Refer to Table 3</p> <p>Dead Band: User-set within selected input range; fully scalable and set in user-selected engineering units</p> <p>Input to Output Trip Response Time: 256msec maximum from step change on input to alarm state change when alarm is set to trip at mid-point of step</p> <p>Alarm Trip Delay: Programmable from 0-120 seconds (0-60 seconds for firmware versions 1.1.2 and earlier)*</p> <p>Isolation: 500Vrms between case, input, output, and power</p> <p>Dielectric Strength: 1966Vdc for 2 seconds, between case, input, output, and power</p> <p>Power Supply: Universal 21.6-375Vdc or 90-260Vac; *24DC range, 18-30Vdc; *UAC range, 90-260Vac</p> <p>Power Consumption: 5W maximum for Universal; 3.5W maximum for DC supply; 4W maximum for UAC supply</p> <p>Power Supply Effect: ±0.002% of span per 1% line voltage change</p> <p>Input Over-Range Protection: ±5Vdc, maximum</p> <p>Input Resistance: T/C and mV inputs, 40Mohms, nominal</p> <p>Excitation Current: RTD and Ohms, 250 microamps, ±10%</p> <p>Output Relays</p> <p>Dual Process Relays and One Fault Relay (Relays are single-pole/double-throw SPDT, 1 form C, rated 3A@250Vac or 3A@30Vdc, 50/60Hz, non-inductive)</p> <p>* Power supply option no longer available for purchase</p>	<p>Performance of Analog Output (-AO Option)</p> <p>Analog Output Option</p> <p>Output Accuracy: Current, ±0.01% of maximum span (±2 microamps); Voltage, ±0.01% of maximum span (±1mV)</p> <p>Input to Output Response Time: 256msec for the output to change 10% to 90% of its scale for an input step change of 0 to 100%</p> <p>Output Step Response Time: 100msec maximum</p> <p>Output Ripple (up to 120Hz): 50mV peak-to-peak maximum on voltage output; 10mV peak-to-peak measured across a 250 ohm load resistor for current output (frequencies up to 120Hz)</p> <p>Analog Output Range: Current Output 0-21.6mA, Minimum Span 4mA; Voltage Output -0.2-10.5V; Minimum Span 1V</p> <p>Output Current Limiting: Current outputs:</p> <table border="1"> <thead> <tr> <th>Output</th> <th>Failure Limits</th> </tr> </thead> <tbody> <tr> <td>0-20mA</td> <td>0, 23.6mA</td> </tr> <tr> <td>4-20mA</td> <td>3.6, 23.6mA</td> </tr> <tr> <td>X-20mA (0<X<4)</td> <td>(90% of X), 23.6mA</td> </tr> </tbody> </table> <p>Voltage output: Failure Limit: -0.50 -11.0V</p> <p>Load Capability: Source mode (internal power supply), 0-1 kohms for current output; 2 kohms for voltage output; Sink Mode (External power Supply), 42Vdc Max</p> <p>Load Effect (current outputs): ±0.01% of span from 0 to maximum load resistance on current output</p> <p>Ambient Conditions</p> <p>Operating Range: -40°C to +85°C (-40°F to +185°F)</p> <p>Relay Range: -40°C to +85°C (-40°F to +185°F)</p> <p>Storage Range: -40°C to +85°C (-40°F to +185°F)</p> <p>Ambient Temperature Effect: Refer to Table 4</p>	Output	Failure Limits	0-20mA	0, 23.6mA	4-20mA	3.6, 23.6mA	X-20mA (0<X<4)	(90% of X), 23.6mA	<p>Ambient Conditions (continued)</p> <p>Effect of Ambient Temperature on Reference Junction Compensation (T/C inputs only): ±0.005°C per °C change of ambient temperature;</p> <p>With Non-Safety-Critical Analog Output: ±0.009% of maximum span/°C</p> <p>Relative Humidity: 5-95%, non-condensing</p> <p>RFI/EMI Protection: 20V/m@80-100MHz, 1kHz AM, when tested to IEC61326</p> <p>Noise Rejection: Common Mode, 100dB@50/60Hz Normal Mode, refer to Table 5</p> <p>Adjustments</p> <p>Front panel push-buttons for parameter configurations; Internal jumper and menu password protect parameter settings</p> <p>Indicators</p> <p>LCD: 2x5 14-segment characters, backlit, alphanumeric readout accurate to the nearest digit.</p> <p>Range: -99999 to 99999; Decimal point can be user-set</p> <p>LED Type: INPUT LED: Dual color LED indicates input failure READY LED: Green LED indicates unit is operating properly ALARM 1 and 2 LED: Dual color LED per relay indicates alarm status FAULT LED: Green LED indicates unit is operating properly; Red LED indicates unit has fault or is latched.</p> <p>Display Accuracy: ±1 digit; when scaling the display (or in custom mode), high input-to-display span ratios decrease display accuracy</p> <p>Weight 527 g to 581 g (18.6 oz to 20.5 oz)</p>
Output	Failure Limits									
0-20mA	0, 23.6mA									
4-20mA	3.6, 23.6mA									
X-20mA (0<X<4)	(90% of X), 23.6mA									

Table 3. Long-Term Stability (TPRG Input Model)

Stability (% of conformance range)	Input to Analog Output (Years)			Input to Relay (Years)		
	1 yr	3 yrs	5 yrs	1 yr	3 yrs	5 yrs
	0.067	0.116	0.15	0.012	0.020	0.026

SIL 2 and SIL 3 Capable Programmable Current/Voltage and RTD/Thermocouple Safety Trip Alarms

Table 2. Accuracy (TPRG Input Model)

Input	Type	α	Ohms	Conformance Range	Minimum Span	Input Accuracy/ Repeatability	Maximum Range
RTD 2-Wire, 3-Wire, 4-Wire	Platinum	0.003850	100	-200 to 850°C (-328 to 1562°F)	10°C (18°F)	±0.1°C (±0.18°F)	-240 to 960°C (-400 to 1760°F)
			200				
			300				
			400				
			500				
	Platinum	0.003902	100	-100 to 650°C (-148 to 1202°F)			-240 to 580°C (-400 to 1076°F)
			200				
			400				
			500				
			1000				
Nickel	0.00672	120	-80 to 320°C (-112 to 608°F)	-100 to 360°C (-148 to 680°F)			
Copper	0.00427	9.035	-50 to 250°C (-58 to 482°F)	-65 to 280°C (-85 to 536°F)			
Ohms	Direct Resistance	n/a	0-4000	0-4000 ohms	10 ohms	±0.4 ohms	0-4095 ohms
	Potentiometer	n/a	100-4000	0-100%	10%	±0.1%	0-100%
T/C	J	n/a	n/a	-180 to 760°C (-292 to 1400°F)	35°C (63°F)	±0.25°C (±0.45°F)	-210 to 770°C (-346 to 1418°F)
	K	n/a	n/a	-150 to 1370°C (-238 to 2498°F)	40°C (72°F)	±0.3°C (±0.54°F)	-270 to 1390°C (-454 to 2534°F)
	E	n/a	n/a	-170 to 1000°C (-274 to 1832°F)	35°C (63°F)	±0.2°C (±0.36°F)	-270 to 1013°C (-454 to 1855.4°F)
	T	n/a	n/a	-170 to 400°C (-274 to 752°F)	35°C (63°F)	±0.25°C (±0.45°F)	-270 to 407°C (-454 to 764.6°F)
	R	n/a	n/a	0 to 1760°C (32 to 3200°F)	50°C (90°F)	±0.55°C (±0.99°F)	-50 to 1786°C (-58 to 3246.8°F)
	S	n/a	n/a	0 to 1760°C (32 to 3200°F)	50°C (90°F)	±0.55°C (±0.99°F)	-50 to 1786°C (-58 to 3246.8°F)
	B	n/a	n/a	400 to 1820°C (752 to 3308°F)	75°C (135°F)	±0.75°C (±1.35°F)	200 to 1836°C (392 to 3336.8°F)
	N	n/a	n/a	-130 to 1300°C (-202 to 2372°F)	45°C (81°F)	±0.4°C (±0.72°F)	-270 to 1316°C (-454 to 2400.8°F)
	C	n/a	n/a	0 to 2300°C (32 to 4172°F)	100°C (180°F)	±0.8°C (±1.44°F)	0 to 2338°C (32 to 4240.4°F)
mV	DC	n/a	n/a	n/a	4mV	±30 microvolts	-50 to 1000mV

Table 4. Ambient Temperature Effect (TPRG Input Model)

Accuracy per 1°C (1.8°F) Change in Ambient	
RTD*	0.0035°C
Millivolt	0.5 microvolts + 0.005% of reading
Ohm	0.002 ohms + 0.005% of reading
Thermocouple	
Accuracy per 1°C (1.8°F) Change in Ambient	
J	0.00016°C + 0.005% of reading
K	0.0002°C + 0.005% of reading
E	0.00026°C + 0.005% of reading
T	0.0001°C + 0.005% of reading
R, S	0.00075°C + 0.005% of reading
B	0.0038°C + 0.005% of reading
N	0.003°C + 0.005% of reading
C	0.00043°C + 0.005% of reading
mV	0.5 microvolts + 0.005% of reading

*Accuracy of Ni672 is 0.002°C

Table 5. Normal Mode Rejection Ratio (TPRG Input Model)

Sensor Type	Max. p-p Voltage Injection for 100dB at 50/60Hz	
T/C: J, K, N, C, E	150mV	
T/C: T, R, S, B	80mV	
Pt RTD: 100, 200, 300 ohms	250mV	
Pt RTD: 400, 500, 1000 ohms	1V	
Ni: 120 ohms	500mV	
Cu: 9.03 ohms	100mV	
Resistance	mV	
1-4 kohms	250-1000	1V
0.25-1 kohms	62.5-250	250mV
0.125-0.25 kohms	31.25-62.5	100mV

SIL 2 and SIL 3 Capable Programmable Current/Voltage and RTD/Thermocouple Safety Trip Alarms

Ordering Information

Unit	Input	Output	Power	Options	Housing
STA Programmable SIL 2 Compliant Programmable Safety Trip Alarm	HLPRG Programs to accept: <u>Current:</u> Any range between 0-50mA including: 0-20mA, 4-20mA, 10-50mA <u>Voltage:</u> Any range between 0-10Vdc including: 0-5Vdc, 1-5Vdc, 0-10Vdc TPRG Programs to accept: <u>RTD:</u> 2-, 3- and 4-wire; platinum, copper, and nickel <u>Thermocouple:</u> J, K, E, T, R, S, N, C, B <u>Ohms:</u> 0-4000 ohms (Potentiometer, 4000 ohms max.) <u>Millivolts:</u> -50 to +1000mV	3PRG Dual Process Relays and One Fault Relay (Relays are single-pole/double-throw; SPDT, 1 form C, rated 3A@250Vac or 3A@30Vdc, 50/60Hz, non-inductive) Process Relays #1 and #2 individually configure for: High Alarm Low Alarm Normally Open Normally Closed (Both relays are fixed as Failsafe) Fault Relay #3 is fixed as Failsafe	U Accepts any power input range between 21.6-375Vdc or 90-260Vac	-AO Analog output (isolated and linearized) scalable for any range between 0-21.6mA into 1 kohms or -0.2-10.5V into 2 kohms (Current output is user-selected for internal, source or external power, sink)	DIN DIN-style housing mounts on 35mm (EN50022) Top Hat DIN-rails FLB Flange bracket provides a secure mount for high vibration applications

When ordering, specify: Unit / Input / Output / Power / Options [Housing]

Model number example: STA / TPRG / 3PRG / U / -AO [DIN]

Accessories:

Part Number 700-702-32	FMEDA Report consistent with IEC 61508-2:2010 providing the information necessary to design a Safety Instrumented System (One copy provided free with each order Upon Request)
Part Number 750-75E05-01	Intelligent PC Configuration Software (One copy provided free with each order)
Part Number 803-053-26	Serial Configuration Cable for use in connecting the STA to a PC
Part Number 804-030-26	Fuse Protected, Non-Isolated USB Communication Cable

To Request a FMEDA (Failure Modes, Effects and Diagnostics Analysis) Report with a STA Safety Trip Alarm Order, See "Accessories"

Figure 9. Installation Dimens:

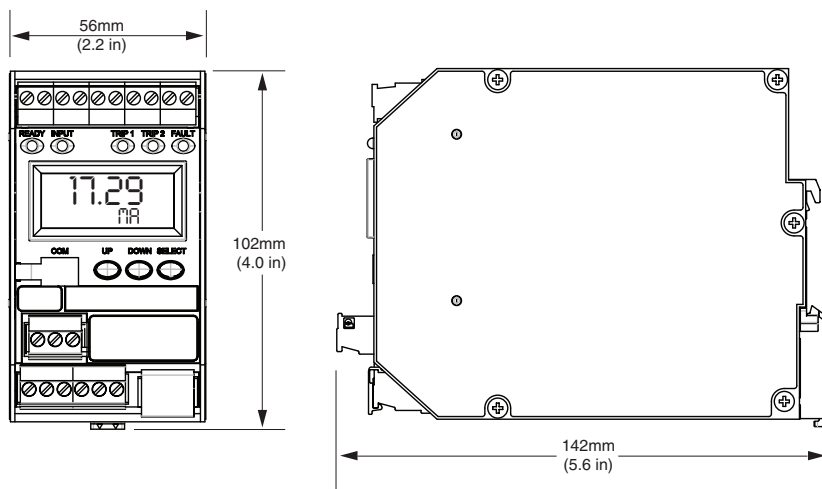

NOTE: While all STA models (model with HLPRG input shown) are dimensionally identical, the STA that accepts temperature inputs (TPRG input) features metal terminal blocks for enhanced reference junction compensation.

For Terminal Designations, see the STA HLPRG and STA TPRG Installation Manuals on the Moore Industries Web Site: www.miinet.com