

STA^{HLPRG}

Programmable Current/Voltage Safety Trip Alarm



STA^{HLPRG}

Programmable Current/Voltage Safety Trip Alarm



User's Manual

225-748-01L
February 2017



Demand Moore Reliability

Customer Support

Moore Industries is recognized as the industry leader in delivering top quality to its customers in products and services. We perform a sequence of stringent quality assurance checks on every unit we ship. If any Moore Industries product fails to perform up to rated specifications, call us for help. Our highly skilled staff of trained technicians and engineers pride themselves on their ability to provide timely, accurate, and practical answers to your process instrumentation questions. Our headquarters and other facilities phone numbers are listed below.

There are several pieces of information that can be gathered before you call the factory that will help our staff get the answers you need in the shortest time possible. For fastest service, gather the complete model and serial number(s) of the problem unit(s) and the job number of the original sale.

World Headquarters

16650 Schoenborn Street
North Hills, California
91343-6196, U.S.A.
Tel: (818) 894-7111
Fax: (818) 891-2816
E-mail: info@miinet.com
TOLL FREE: 1-800-999-2900
www.miinet.com

Europe

1 Lloyds Court, Manor Royal,
Crawley
W. Sussex RH10-9QU
United Kingdom
Tel: 01293 514488
Fax: 01293 536852
FREE PHONE: 0800 525107
sales@mooreind.com
www.miinet.com/uk

Australia

Sydney, NSW
3/1 Resolution Drive
Caringbah, New South Wales
2229
Australia
Tel: (02) 8536-7200
Fax: (02) 9525-7296
sales@mooreind.com.au
www.miinet.com/au

China

Room 806, Block 2,
Lotus International Plaza
No. 7866 Hu Min Road,
Min Hang District,
Shanghai, 201102, P. R. China
Tel: 86-21 62491499
Fax: 86-21 62490635
E-mail: sales@mooreind.sh.cn
www.miinet.com/cn

Guido Gezellestraat 106
B-2630 Aartselaar
Belgium
Tel: 03/448.10.18
Fax: 03/440.17.97
info@mooreind.be
Dutch: www.miinet.com/dbe
French: www.miinet.com/fbe

Perth, WA
6/46 Angove Street
North Perth, Western Australia
6006
Australia
Tel: (08) 9228-4435
Fax: (08) 9228-4436
sales@mooreind.com.au
www.miinet.com/au

Burg Meslaan 98
4003 CD Tiel
The Netherlands
Tel: (0)344-617971
Fax: (0)344-615920
sales@mooreind.nl
www.miinet.com/nl



www.miinet.com

Safety Messages

Please read this manual in its entirety. It should answer most of your questions. For personal and system safety, and for optimum product performance, make sure you thoroughly understand the contents before installing, using, or maintaining this product. Should you still have questions please visit our web site at www.miinet.com or contact any of our sales/support offices nearest you.

Your safety and the safety of others is very important. We have provided many important safety messages in this manual. Please read these messages carefully. These safety messages alert you to potential hazards that could hurt you or others or render damage to units.

All Moore Industries instrumentation should only be used for the purpose and in the manner described in this manual. If you use this product in a manner other than that for which it was intended, unpredictable behavior could ensue with possible hazardous consequences.

Each safety message is associated with a safety alert symbol. These symbols are found in the throughout the manual. The definition of these symbols is described below:

Pay particular attention wherever you see the following symbols:



Note – Information that is helpful for a procedure, condition or operation of the unit.



Caution – Hazardous procedure or condition that could damage or destroy the unit.



Warning – Hazardous procedure or condition that could injure the operator.

Qualified Personnel

The Moore Industries' product/systems described in this manual may be operated only by personnel qualified for the specific task in accordance with the relevant documentation, in particular its warning notices and safety instructions. Qualified personnel are those who, based on their training and experience, are capable of identifying risks and avoiding potential hazards when working with these Moore Industries' products/systems.

Proper use of Moore Industries products

Moore Industries' products may only be used for the applications described in the catalog and in the relevant technical documentation. If products and components from other manufacturers are used, these must be recommended or approved by Moore Industries'. Proper transport, storage, installation, assembly, commissioning, operation and maintenance are required to ensure that the products operate safely and without any problems. The permissible ambient conditions must be complied with. The information in the relevant documentation must be observed.

We have reviewed the contents of this publication to ensure consistency with the hardware and/or software described. Since variance cannot be precluded entirely, we cannot guarantee full consistency. However, the information in this publication is reviewed regularly and any necessary corrections are included in subsequent editions. Specifications and information are subject to change without notice.

All product and company names are trademarks™ or registered® trademarks of their respective holders. Use of them does not imply any affiliation with or endorsement by them unless otherwise specified.

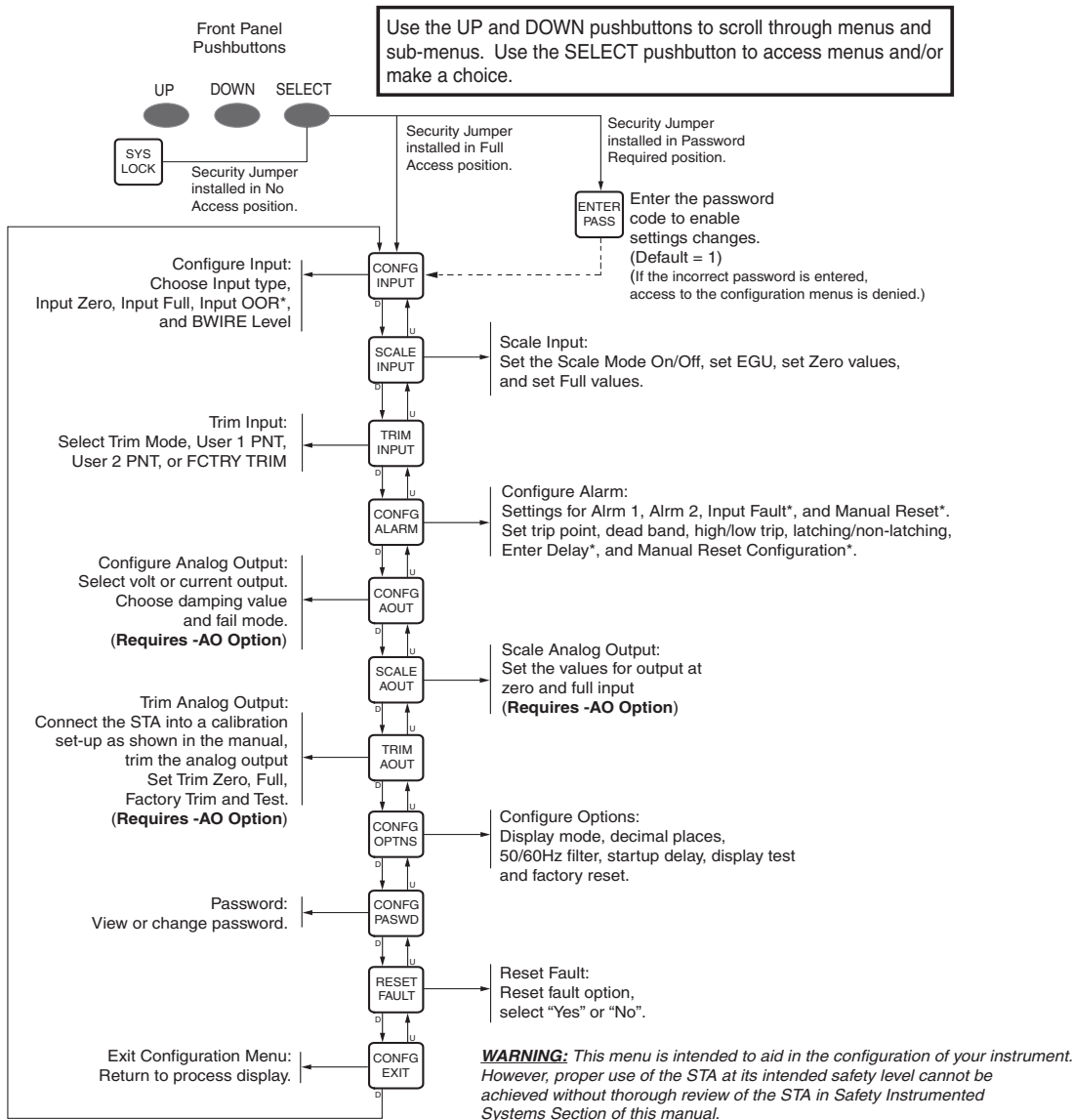
Table of Contents

STA (HLPRG) Quick Start Guide	5
Default/Factory Configuration	6
Section 1 - Introduction	7
Overview.....	7
Description.....	7
Model Numbers and Options.....	8
Alarm Terminology	10
Section 2 - Calibration and Bench Check	12
Calibration.....	12
Bench Check.....	12
Section 3 - Installation and Wiring	15
Dimensions	15
Conditions of Use.....	16
Terminal Designations	17
Security Settings	21
Section 4 - STA Front Panel Configuration	22
Section 5 - STA PC Configuration	45
Section 6 - Operation and Maintenance	60
Operation	60
STA Diagnostics & Fault Alarms	60
STA Diagnostic Messages	61
Maintenance.....	62
Section 7 - STA in Safety Instrumented Systems	63
Proof Tests	67
Section 8 - Applications	69
High Integrity Alarm Trip.....	69
High Availability Architecture.....	69
1oo2 Redundant Architecture	70
Analog Output in the Safety Path	71
High Integrity Analog Output	71
Section 9 - Specifications	72
Section 10- Ordering Information	74
Warranty Disclaimer	76

STA (HLPRG) Quick Start Guide

Use the front pushbuttons to quickly and easily set-up the STA for your application. After programming your alarm using the diagram below, install the unit into your application using the connection diagrams and terminal designation table located in this manual.

The STA configuration can be recorded using the worksheet found at the end of this manual. Please contact Moore Industries Sales for an interactive version of the worksheet.



* For STA units with firmware versions 1.4 and earlier, these Settings are not configurable.

Default/Factory Configuration

The following are the default factory settings for your unit.

Input: 4-20mA

***Lower Out of Range Value:** 3.84 mA (1% of Span)

***Upper Out of Range Value:** 20.16 mA (1% of Span)

***Startup Delay:** 0 Seconds

Scale Mode: Off

Trim Mode: Factory Trim

Trip Alarms: Trip High at 12mA with Deadband set to 0

***Input Fault Alarm:** Latching (On)

***Manual Reset:** Trip Alarms 1 & 2 Only

Optional Analog Output (AO): Current, No Damping, Fail Low, Scaled to 4-20mA

Display: Process Variable (PV), Auto Decimal Point, 60Hz Filter

Broken Wire Detection: Level Set to 0 (disabled)

Password: 1

** For STA units with firmware versions 1.5 and earlier, these Settings are not configurable.*

Section 1 - Introduction

This is the user's manual for Moore Industries' STA (HLPRG): Programmable Current/Voltage Safety Trip Alarm.

The Moore Industries' Safety Trip Alarm (STA) is designed and manufactured to provide a high level of availability for safety critical applications and for use as a component part of a safety instrumented system.

Overview

This manual contains all of the information needed to configure, install, operate and maintain this product. When the STA is used in a SIL rated safety application (as defined by IEC 61508), the Safety Instrumented Systems section of this manual must be read and followed in order for the STA to meet its IEC 61508 certification requirements.

Description

Moore Industries' STA (HLPRG) is a Programmable Current/Voltage Safety Trip Alarm.

The STA monitors a process variable and provides two fully user-configurable contact closure outputs that can be individually programmed to trip whenever the input falls outside a user-set, high or low trip point. It also has one fault alarm output which is triggered by a self-diagnosed failure of the input or the STA itself. The STA is typically used to activate a warning light, bell or buzzer; or to initiate a system shutdown. Thus, the instrument acts as a simple, but highly reliable and effective means of monitoring and safe-guarding a process.

The STA may be configured using front panel push buttons and/or Moore Industries' PC Configuration Software. A large 5-digit display shows menu prompts during push button configuration and process variable and status messages during normal operation.

The STA also has a password security feature to limit access to the front panel configuration. Refer to Security Settings in the Installation and Wiring Section for more details.

All STA diagnostic faults are latching and input faults can be configured to latch or not latch. User configuration faults will clear automatically once the configuration is valid. If input faults are latched, these can be cleared by the "RESET FAULT" menu and the Manual Reset (MR) terminal can also be configured to reset both latched Trip Alarms and input faults. Unit faults such as internal diagnostics will always latch the Fault Alarm and the unit must be power cycled to clear the alarm.

Note: For STA units with firmware versions 1.5 and earlier, the fault alarm has no configuration options, is always latched and cannot be reset by Manual Reset (MR).



Model Numbers and Options

The following section provides details of the Moore Industries model number and the available options for the STA.

Moore Industries model numbers for STA are structured as follows:

STA / HLPRG / 3PRG / U / -AO [DIN]

Unit / Input / Output / Power / -Options [Housing]

Refer to **Section 10 Ordering Information** for a quick reference table of ordering information

INPUT

HLPRG

The STA (HLPRG) supports either current inputs from 0-50mA (4mA minimum span) or voltage inputs from 0-11V (1V minimum span). These inputs can be trimmed and scaled, refer to the Configuring Inputs section of this manual for additional information.

OUTPUT

3PRG

The STA has three programmable contact closure alarms. One relay is factory configured as a Fault alarm and the remaining two relays are user-configurable Trip alarms. A dual color LED (Red/Green) is provided with each alarm to indicate its condition.

The fault alarm trips on a self-diagnosed failure within the STA or on any of its inputs. This alarm is latching and has to be reset by the user. Only user configuration faults will clear automatically once the configuration is valid. Input faults can be configured to Latch or not Latch and can be cleared by the "RESET FAULT" menu or by the MR terminals if configured to reset both latched Tripped Alarms or input faults. Self-Diagnosed unit faults can only be cleared by power cycling the unit.



Note: For STA units with firmware versions 1.5 and earlier, the fault alarm has no configuration options, is always latched and cannot be reset by Manual Reset (MR).

For more information refer to the Diagnostics and Fault Alarm section.

The Trip alarms are configurable for high or low trip with an adjustable dead band. These alarms can be latching or non-latching. Latched alarms are reset through the Manual Reset (MR) terminals.

The relay outputs have a 3A@250Vac or 3A@30Vdc, 50/60Hz non-inductive contact rating. The contact arrangement is SPDT (1FormC). All outputs are fail safe and will deenergize to trip (DET) with normally open (NO) and normally closed (NC) relay contacts.

Refer to the Alarm Terminology and Configuring the Alarms sections of this manual for additional information.

POWER

U

Accepts any power input range between 21.6-375Vdc or 90-260Vac. Power consumption is 5W maximum.

24DC*

This option instrument requires power is 24Vdc, $\pm 25\%$. Power consumption is 3.5W maximum.

UAC*

Accepts any power input range between 90-260Vac. Power consumption is 4W maximum.

*Power supply option no longer available for purchase.

OPTIONS

-AO

If your STA has the Analog Output option, Analog Output can be configured to provide a voltage (0-10V) or current (0-20mA) output. The current output can be sink or source. Refer to the Configuring the Analog Output section of this manual for additional information.



Note: For units with firmware V1.2 or earlier, the Analog Output cannot be used as part of the safety path.

HOUSING

[DIN]

DIN-style housing mounts on a 35mm Top Hat rail (EN50022)

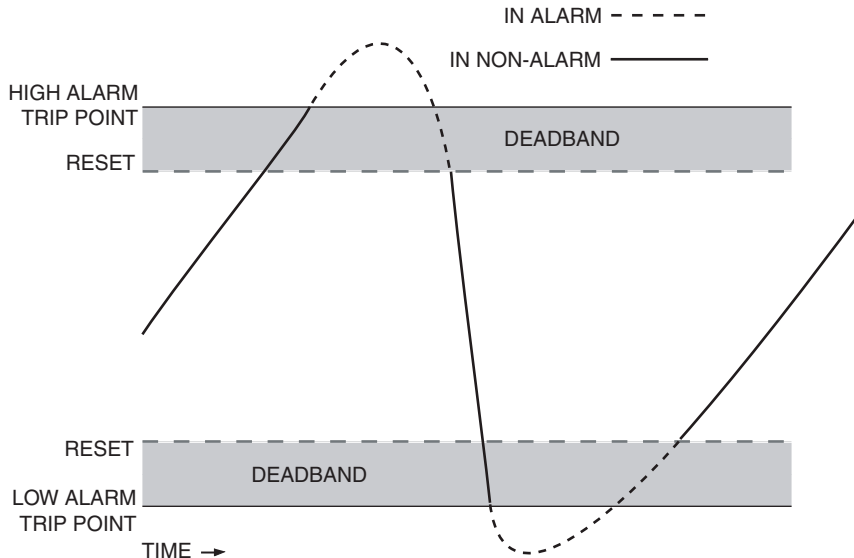
[FLB]

Flange bracket provides a secure mount for high vibration applications.

Alarm Terminology

Before setting up the STA, or incorporating the unit in your application, Moore Industries suggests that all users take a few moments to become familiar with some of the terms associated with the use of process instrumentation alarms.

Figure 1.1. How Alarms Work with the Process Input



The **Trip Point** is the process input level at which the user wants an alarm relay to change state, typically going into an alarm condition, or “tripping”. In the STA, the user sets the trip point for each alarm relay.

High/Low Alarms; High Alarms trip when the process input goes above the trip point. Low Alarms trip when the process input drops below the trip point. Each of the STA relay outputs can be set by the user to function independently as either high or low alarms.

Latching and Non-latching Alarms; once tripped, a latching alarm remains in an alarm state until the input returns to a non-alarm level AND is manually reset. Non-latching alarms return to a non-alarm state whenever the process input returns to the Reset Point. The STA relays can be set by the user to function as either latching or non-latching.

The **Reset Point** is the process input level at which the user wants an alarm relay to change state, typically going from alarm to non-alarm. The reset point is not necessarily the same as the trip point, because most applications call for a buffer zone or deadband around the trip point to allow for minute fluctuations in the process input. In the STA, the reset point is determined by the **deadband** setting. Latching STA alarms will not “clear” unless the reset point has been reached or passed AND the manual reset contacts have been shorted.

The **deadband** is the range in which an alarm remains tripped even after the process input has returned to or passed the trip point. Deadband is not required. When it is not incorporated into a non-alarm application, the trip point and reset point are the same. The deadband of the STA is set by the user.

Failsafe Alarms are de-energized when tripped, energized when the process input is at a non-alarm level. Non-failsafe alarms are energized whenever tripped, de-energized when the process input is at a non-alarm level. The relays in the STA are failsafe only. Normal is the term used to describe the “shelf-state” of relay contacts. The contacts of a Normally Open relay are open (infinite resistance) when the relay is not energized. The contacts of a Normally Closed relay are open when the relay is energized (closed when not energized).



Note: Sometimes a non-alarm input level is referred to as being in a “normal” condition. This practice is intentionally avoided in this manual. Do not confuse the term “normal”, as in Normally Open or Normally Closed, with a non-alarm input condition. In this manual, “normal” is an exclusive reference to the shelf state or quiescent state of an alarm’s relay contacts, whether open or closed.

Section 2 - Calibration and Bench Check

It is recommended that you perform a bench check on your instruments prior to installing them in your application.

Calibration

A true calibration of the STA can only be performed at Moore Industries using specialized equipment. We recommend that you check the calibration every year and re-calibrate only when necessary.

However, input trimming increases the measurement accuracy of your instrument by matching the reading of its actual input to its scaling. The STA offers the use of a factory-configured trimming feature ("FACTRY TRIM") or user-set, one-point or two-point ("USER 1 PNT" or "USER 2 PNT") trimming.

Please refer to Section 4 of this manual for instructions to perform Input Trimming via Push button panel or Section 5 using the PC Configuration Software.

Likewise, output trimming increases the measurement accuracy of the STA by calibrating its Analog Output to the device that is receiving the output. This ensures that the instrument is being correctly interpreted.

Please refer to Section 4 of this manual for instructions to perform Output Trimming via Push button panel or Section 5 using the PC Configuration Software.

Table 2.1. Necessary Equipment for Bench Checking the STA (HLPRG)

Device	Specifications
Current and/or Voltage Source	Variable; accurate to $\pm 0.05\%$ of unit span
Power Supply	U: 21.6 - 375 Vdc or 90-260Vac; 24DC: 18-30Vdc; UAC: 90-260Vac
Multimeter	Accurate to $\pm 0.009\%$ of span; e.g., HP Model 3478A

Bench Check

We highly recommend that you perform a bench check of your STA prior to installing it in the field. This will ensure that the STA is operating within your expectations or requirements.

The bench check is a quick way to determine that your STA is functioning as expected. Depending on your organization's requirements, you may also be required to perform a complete Proof Test on your STA. The instructions for the Proof Test can be found in Section 7 of this manual.

As a prelude to performing the bench check you should configure your STA as it is to be used in your final application. Refer to Section 4 for the STA Front Panel Configuration instructions. These instructions are used if you are configuring your STA by using the front panel push buttons. Section 5 contains the instructions for configuring your STA using the STA PC Configuration software.

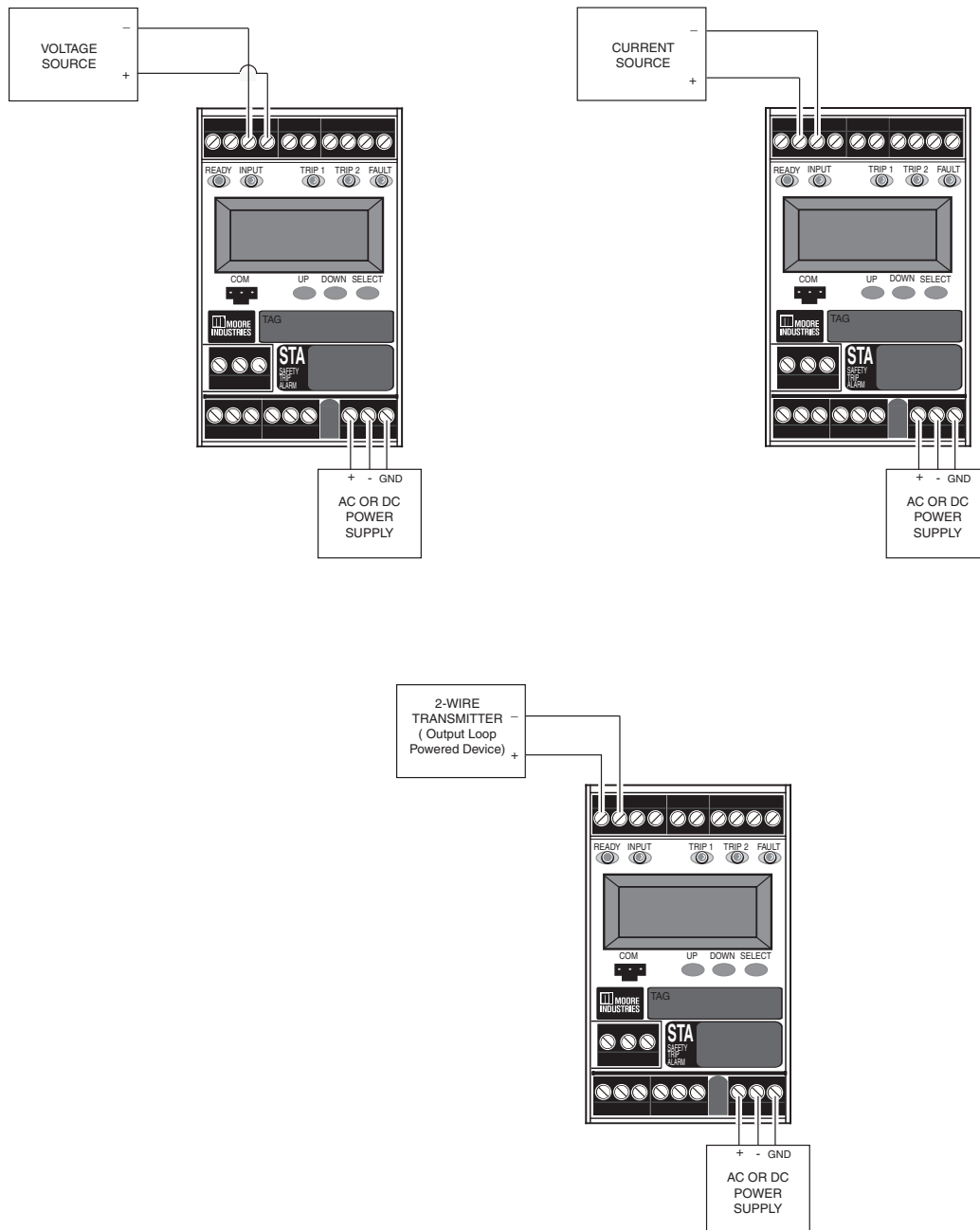
The equipment necessary to perform a bench check can be found in Table 2.1.

Bench Check Procedure

1. Current or Voltage Input:

In order to provide an input to your STA HLPRG you will need to use an appropriate input source. By example – if you plan to use your STA with a current (mA) input you will need to use a milliamp source to provide the appropriate input during your bench check. The same goes for a voltage source. Use whichever input source is correct for your intended application. Please see Figure 2.1 for the correct input connections.

Figure 2.1. STA (HLPRG) Hook-Up Diagram



2. Power Input:
Connect the appropriate power source as shown in Figure 2.1.
3. Set your input source to the low end of your configured input span. By example – if your input is configured for a current (mA) and your input range is set for 4-20mA then use a current source and set it to 4mA. Verify that the STA is reading 4mA on its display window.
4. Set your input source to the high end of your configured input span and verify that the STA's display window correctly reflects the input.
5. Set your input source to a value higher or lower than your configured input span and verify that the Fault Relay changes state. The Fault Relay can be reset via the front panel push buttons or via MR terminals (if configured).
6. Temporarily remove one of your input connections to verify that the Broken Wire feature is working. Note: the Fault Relay can be reset via the front panel push buttons or via MR terminals (if configured).
7. Alarm Relays:
By adjusting your input up and down you can confirm the operation of the Alarm Relays. Use your multimeter (set to ohms) to verify the state of the relay contacts.

Units with the Analog Output option (-AO)

The STA's analog output can be user configured one of three ways – 1) 0-20mA sourced with voltage sourced by the STA (also referred to as I_o Source) or 2) 0-20mA with voltage sourced by the DCS (also referred to as I_o Sink) or 3) 0-10V (also referred to as V_o).

Note that even though 0-20mA is the range of the analog output it can be scaled by the user for a narrower range (such as 4-20mA). The same goes for the voltage output.

1. Connect the analog output as per Figure 3.3. Use the terminals that are correct for your application.
2. When testing the milliamp output it is best to use a 250 ohm precision resistor across the output terminals (as shown in Figure 3.3). Then you can use your multimeter (set to voltage) to read the voltage drop across the resistor. Hence a reading of 1V means that the analog output is putting out 4mA, and a reading of 5V equates to a 20mA output. If using the STAs voltage output terminals (+/-V_o) the voltage can be read directly with your multimeter.
3. Set your input simulator to the low end of your configured input span. Verify that the analog output is correct. By example – a 1V reading across your 250 ohm resistor equates to a 4mA output.
4. Set your input simulator to the high end of your configured input span. Verify that the analog output is correct. By example – a 5V reading across your 250 ohm resistor equates to a 20mA output.

You have now confirmed that your STA is operating correctly and can now be confidently installed into your application.

Section 3 - Installation and Wiring

Instructions in this section and others may require special precautions to ensure the safety of the personnel performing the operations. Notes, Cautions and Warnings that may cause potential safety issues are indicated throughout this manual by symbols, please refer to Page 3 of this manual for the definitions of these safety message symbols.



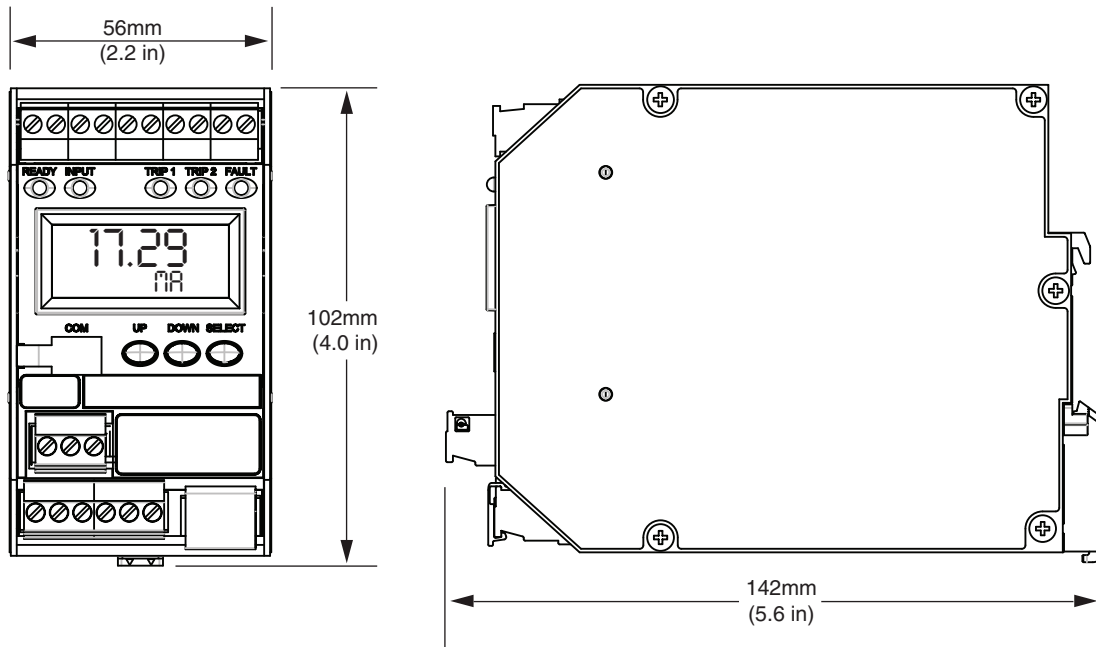
Note: Make sure to calibrate and bench check the instruments prior to installation. Also, install all instruments in their intended application and on their rail before making any electrical connections. Allow enough room for pivoting instruments vertically on the rail for removal in applications involving multiple banks of STAs.



Note: Any changes to Security Settings will need to be made prior to installation and wiring refer the Security Settings Section in this section.

Dimensions

Figure 3.1. Dimensions of STA HLPRG



Mounting

The STA is housed in a DIN case that can be mounted on 35mm Top-Hat (EN50022) DIN-rail. To mount the STA on a Top-Hat DIN-rail, seat the upper extrusion on the unit back panel over the top lip of the rail and pivot downward until the housing locks into place. When mounting multiple units, like a rack or cabinet, make sure to allow adequate vertical spacing for pivoting the units.

A flange bracket option is also provided as a secure mount for high vibration applications. Reference figure 3.2 below.

Removal

To remove the STA from DIN rail you will need a simple tool such as a straight blade screwdriver. Insert the blade of the screwdriver into cavity at the bottom of the locking mechanism and rotate it. This will release the locking mechanism from DIN rail and allow you to remove the STA.

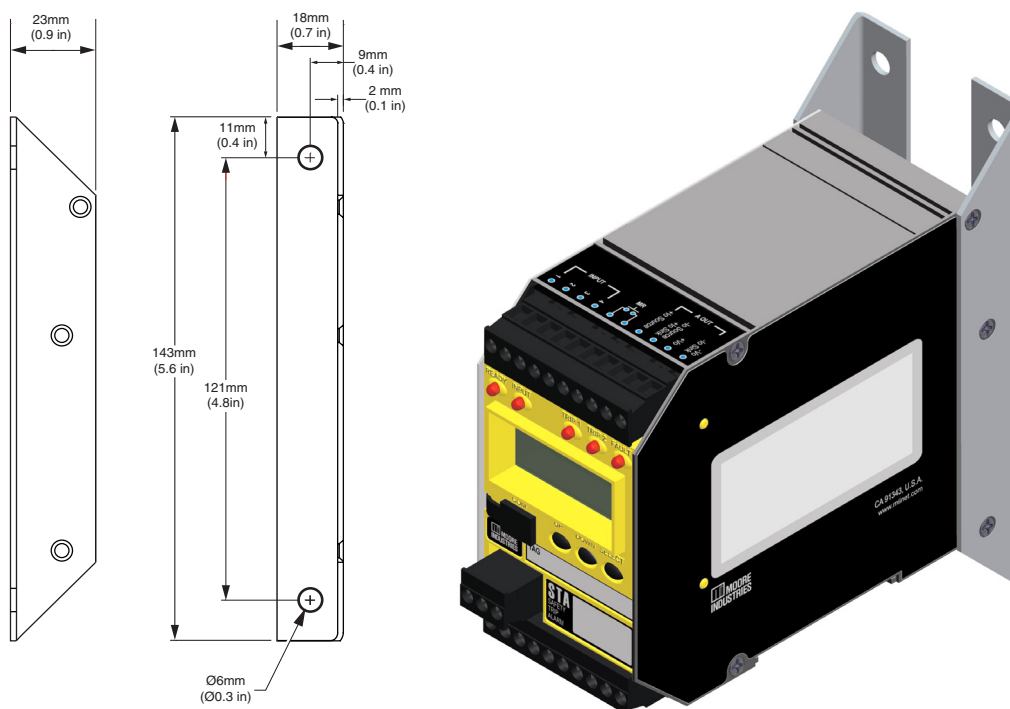
Special Conditions of Use

The following instructions must be adhered to when the STA is used in hazardous locations and potentially explosive atmospheres.

Note: The STA shall be installed in compliance with the enclosure, mounting, spacing and segregation requirements of the ultimate application. Electronic components must be mounted in a suitable enclosure.

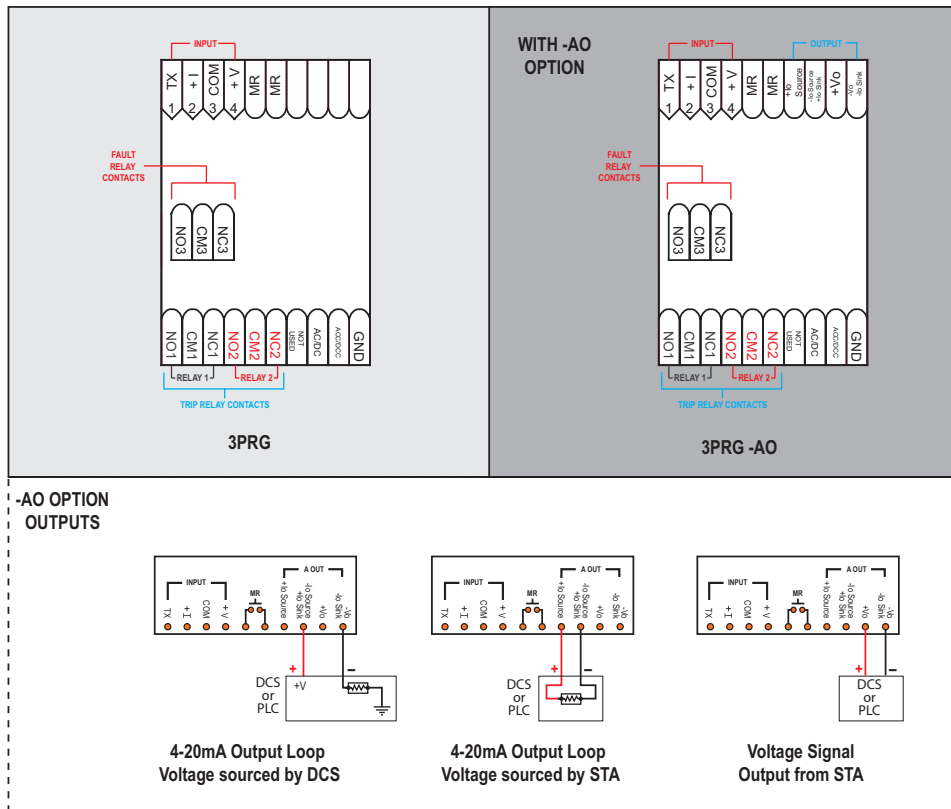


Figure 3.2. FLB flange bracket dimensions.



Terminal Designations

Figure 3.3. Terminal Designations



NOTES:

1. Terminal blocks can accommodate 14-22 AWG solid wiring.
2. ±Io/±Vo labeling is present only when the unit is equipped with the Analog Output (-AO) option.
3. Your input power requirement (AC or DC / ACC or DCC).

KEY:

AC or DC = Power Input	Io = Current Output	Sink = Current Sink
ACC or DCC = Power Input	MR = Manual Reset	Source = Current Source
CM = Relay Common	NO = Normally Open	SPDT = Single-Pole/Double-Throw
GND = Ground	NC = Normally Closed	Vo = Voltage Output

Electrical Connections

Refer to Figure 3.4 for electrical connections.

When installing any Moore Industries product, always follow all local regulations and standards for grounding, shielding, and safety.

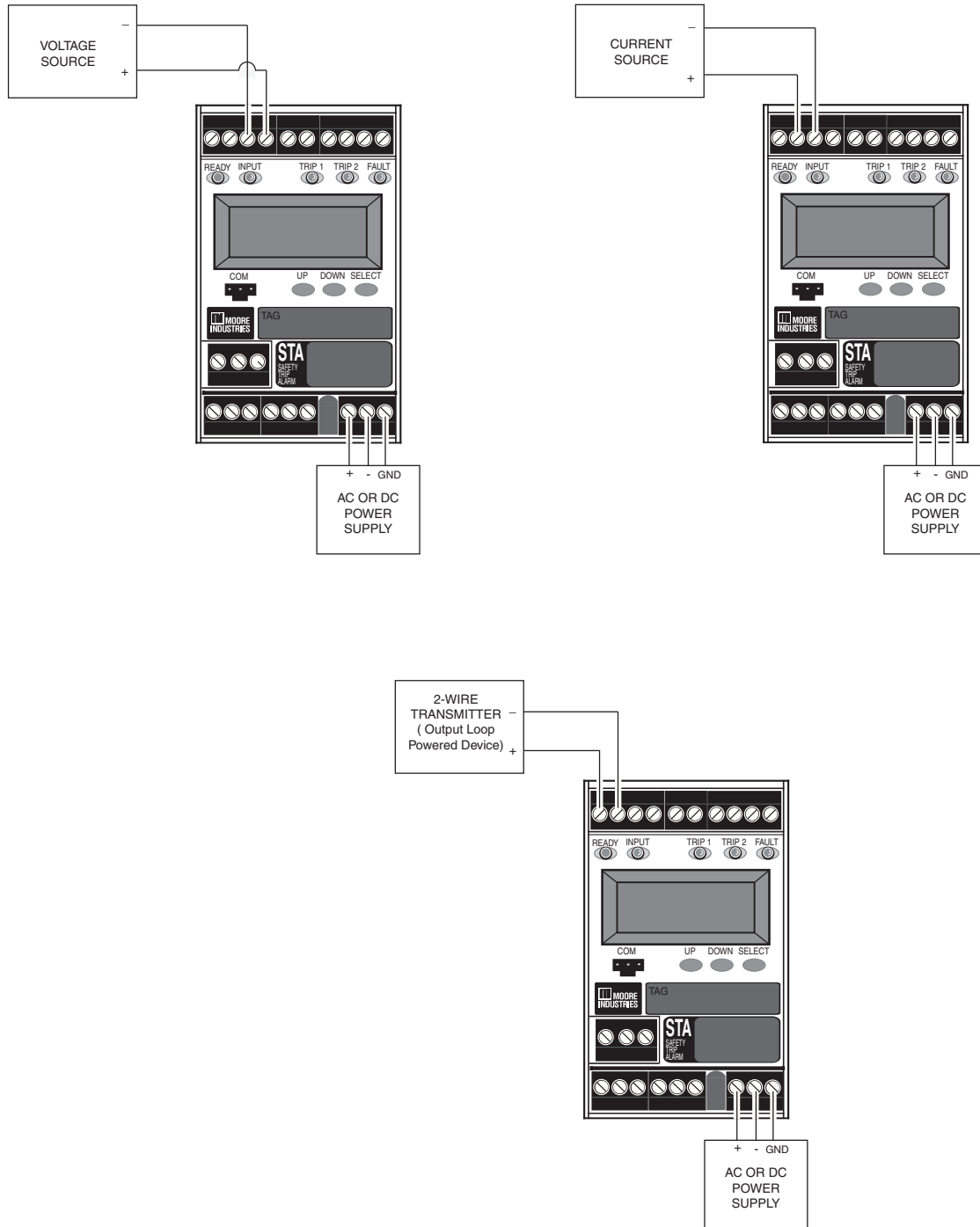


Warning: Terminals on this unit may be connected to hazardous voltages. Before making ANY connections to this unit, always remove power from the loop or instrument power terminals.

Installation Category

All terminals are rated CAT I.

Figure 3.4. STA (HLPRG) Hook-Up Diagram



Equipment Ratings

Contact Relays

The STA does not generate hazardous voltages but can switch outputs up to 3A at up to 250Vac or 30Vdc on its relay contacts. Products connected to the STA should be designed to receive this type of input.

Analog Output

The STA does not generate hazardous voltages, it provides a low current (4-20mA) or voltage (1-5V) input and a 4-20mA output. Products connected to the STA should be designed to receive this type of input.



Warning: *If this unit is used in a manner not specified by Moore Industries, the protection provided by the equipment may be impaired.*

Switches and Circuit Breakers

For STA AC powered units, a switch or circuit breaker must be wired in series with the AC power conductors. The switch or circuit breaker used must be located within three meters of the unit. The circuit breaker or switch will only remove power to the unit; hazardous voltages may still be connected to other terminals on the unit.

Power Supply Wiring

All power connections should be made with 14 or 16 AWG (2mm² or 1.3mm²) wire.

The end of each conductor should be stripped no more than 0.25in (7mm). The end of the stripped wire should be tinned with solder, or inserted into a ferrule and crimped before being placed into a terminal block.

Tighten the screws on the terminal block to 4.4 - 5.3 lbf/in² (0.5 - 0.6 N/m²).

Protective Earth Conductor

The Protective Earth Conductor shall be of equal or larger size wire than the other two power conductors. The Protective Earth Conductor shall be the first conductor connected to the unit when the unit is being wired. It shall be the last conductor removed when the unit is being un-wired.

Input/Output Wiring

The Input/Output connections can be made with 14 to 24 AWG (2.5mm² to 0.2mm²) wire. The end of each conductor should be stripped no more than 0.25in (7mm). Tighten the screws on the terminal block to 4.4 - 5.3 lbf/in² (0.5 - 0.6 N/m²).

Recommended Ground Wiring Practices

Moore Industries recommends the following ground wiring practices:

- Any Moore Industries product in a metal case or housing should be grounded.
- The protective earth conductor must be connected to a system safety earth ground before making other connections.
- All input signals to, and output signals from, Moore Industries' products should be wired using a shielded, twisted pair wiring technique. Shields should be connected to an earth or safety ground.
- For the best shielding, the shield should be run all the way from the signal source to the receiving device. (see Note below)
- The maximum length of un-shielded input and output signal wiring should be 2 inches.



Note: Some of Moore Industries' instruments can be classified as receivers (IPT², IPX², etc.) and some can be classified as transmitters (TRX, TRY, etc.) while some are both a receiver and a transmitter (SPA², HIM, etc.). Hence, your shield ground connections should be appropriate for the type of signal line being shielded. The shield should be grounded at the receiver and not at the signal source.



CE Certification-related Guidelines

Installation of any Moore Industries' products that carry the CE marking must adhere to the guidelines in the Recommended Ground Wiring Practices section in order to meet the EN 61326 requirements set forth in the applicable EMC directive.

The Low Voltage Directive also applies to the AC powered versions of the STA and/or when connecting any of its output relay contacts to voltages greater than 50 vac. In order to comply with EN61010-1 (Low Voltage Directive) all guidelines in this section must be followed.

Contact/Load Suppression

When the instrument relays are used to switch an inductive load such as an external relay coil, contactor, solenoid, large voltage spikes may be created in nearby cable harnesses. When excessive, these voltage spikes can disrupt the operation of all nearby electronics including this product. Inductive loads should have suppression devices installed at the load (for external relays this would be right across the relay coil itself). Usually this is a simple diode for dc circuits. AC circuits routinely use an R-C snubber. Please follow the external load manufacturer instructions for their recommended suppression kits.

Security Settings

The default security password is 1. This is valid until the password is changed to another value.

Password Setting

The STA can operate in one of three password modes (default is set to **Password Required**). The password modes can only be changed by the Security Jumper. Please contact Customer Support for more information.

Full Access – Complete access to the STA configuration menu is permitted with no password required for any read or write operations.

Password Required – A one to four-digit access code is required to gain access to the STA configuration menu. If the correct code is entered, full read and write operation is permitted. If an incorrect code is entered, "WRONG PASWD" will appear for 3 seconds, and return user to View menu, with read-only access to the View menu (see Figure 4.1.).

No Access – The user is limited to read-only access to the View menu. "SYS LOCK" will appear if user attempts to enter Main menu by entering "SEL". Enter "SEL" a second time to return to View Menu.

Note: *These security settings are only applicable to access via the front panel pushbuttons. Security can be bypassed using the PC Configuration Software. See PC Configuration Software section for more information.*



Section 4 - STA Front Panel Configuration

The STA (HLPRG) operating parameters are set using the pushbuttons found on the instrument's front panel or STA Configuration Software. This section describes the steps in order to configure your STA using Front Panel pushbutton method.

Front Panel Push Button Configuration

There are three pushbuttons on the unit's front panel; *UP*, *DOWN* and *SELECT*. Together with the prompts displayed on the LCD, these are used to access menus, and to view and change the settings.

Use *SELECT* as your "Enter" button, to make your selections.

Use the *UP* and *DOWN* buttons to navigate within the menus.

View Menu

Figure 4.1 gives an overview of the View menu.

Upon power-up, the STA displays a 'SYS INIT' message until the power up self test is complete. In normal operation the View menu will display the variable as configured. This can be the process variable, the analog output variable, or both being toggled (Refer to Configuring the Options Menu for more details).

1. From the display, press *DOWN*.
2. If the -AO option is present, and the unit is NOT configured to toggle, the process variable will be displayed. Continue pressing *DOWN* to view the Analog output zero, Analog output full, trip point (AL1), trip point (AL2) and finally returning to display the process variable.
3. Enter Main Menu at any point by pressing *SELECT*.

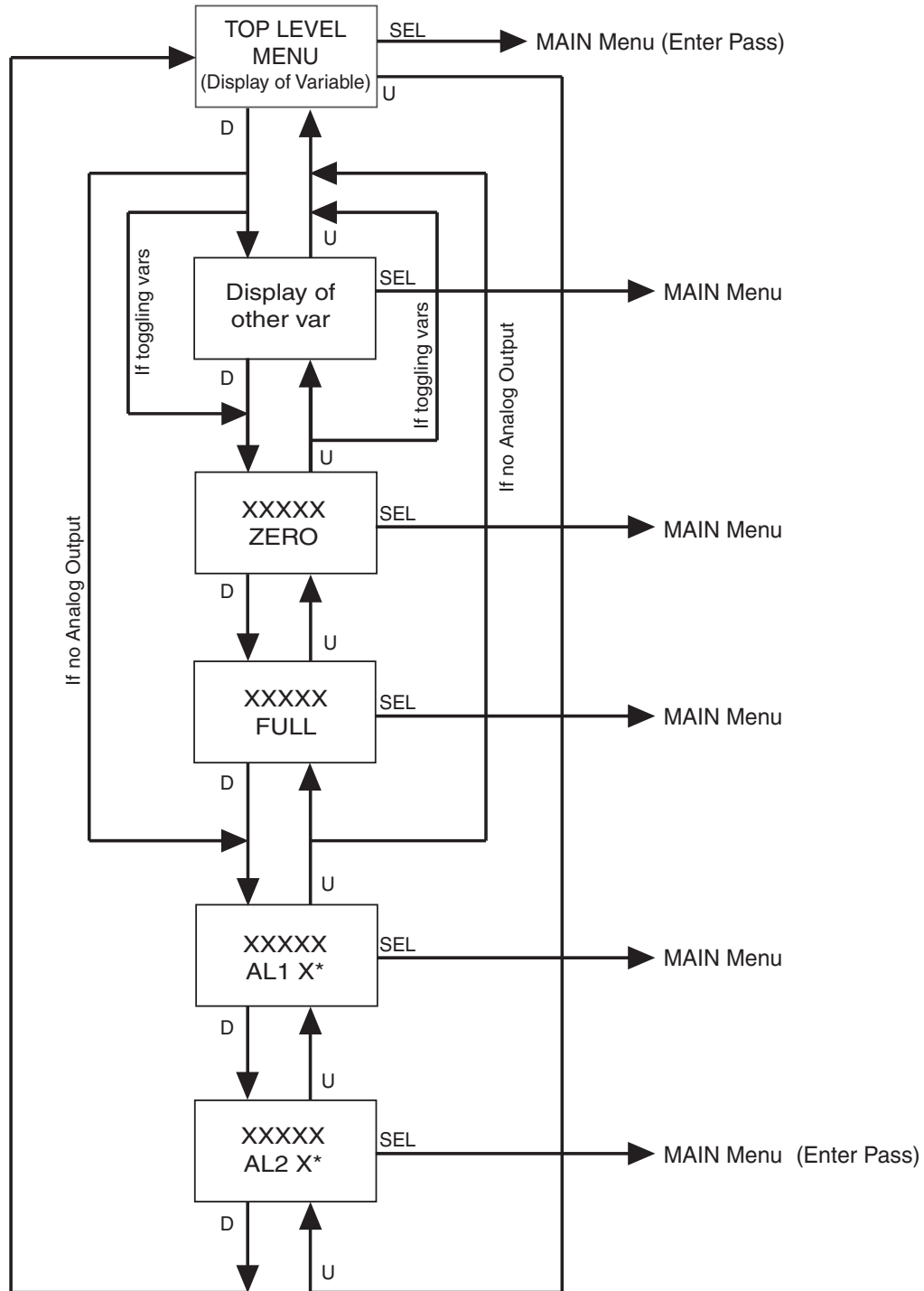
Note: *If the Security is set to No Access entering SELECT will cause "SYS LOCK" to appear if user attempts to enter MAIN menu.*

Under fault conditions, the STA will display the error message describing the fault (see Table 6.1. located in Section 6 - Operation and Maintenance for list of messages) which can be cleared from the Reset Fault menu, MR (if configured) or by power cycling the unit.

Note: *For STA units with firmware versions 1.5 and earlier, the input fault alarm has no configuration options, it is always latched and cannot be reset by Manual Reset (MR).*



Figure 4.1. View Menu



Main Configuration Menu

Figure 4.2 gives an overview of the Main Configuration menu.

Upon power-up, the STA displays the variable(s) as configured via the Configure Options menu. Pressing the *SEL* button accesses a series of displays that show, in succession, the settings currently stored in unit memory.

Depending upon how Security has been set, pressing *SELECT* will access either the first screen in the main configuration menu, "CONFIG INPUT", the password code query screen, "ENTER PASS" or the "SYS LOCK" screen.

Once the Main Menu has been accessed, the *DOWN* button is used to move through all of the sub-menus in a loop. Pressing the *SELECT* button accesses the first screen of the sub-menu shown on the LCD.



Note: STA is programmed to time out from the configuration menu after 5 minutes of inactivity. When trimming the unit, 30 minutes of inactivity are allowed before the time out. If the unit times out, the previous settings will be reapplied.

Password

This menu is bypassed if the Password Security is set to **Full Access**. Refer to the Password Configuration section of this manual for a more detailed description of the password feature.

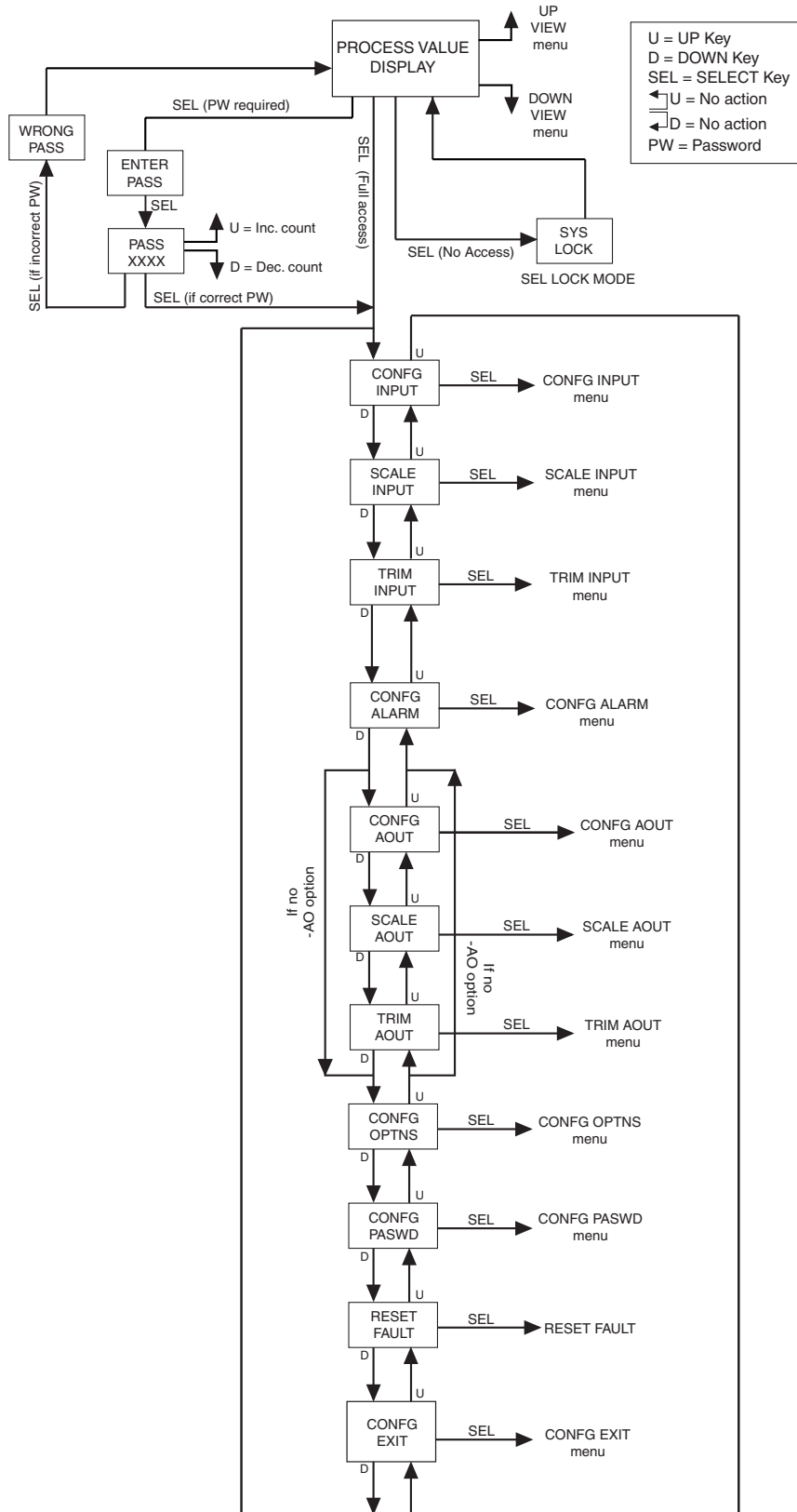
1. If the Password Security is set to Password Required, pressing *SELECT* from the display of the process variable input will bring up the "ENTER PASS" screen.
2. Press *SELECT* again to enter the "PASS" screen. Use the *UP* and *DOWN* buttons to select correct password (default value is "1"). When the password is displayed, press *SELECT*.



Note: If the correct password is not known, contact Moore Industries Technical Support for assistance, or use the PC Configuration Software to bypass security.

3. If you have entered the correct password, the sensor configuration menu, "CONFIG INPUT", will be accessed. If not, the display will show a "WRONG PASS" message.
4. From "WRONG PASS", wait three seconds to go back to the View menu. Use the *UP* and *DOWN* buttons to view the settings in the View menu.

Figure 4.2. Main Menu



Configuring the Input

Figure 4.3 gives an overview of the Configuration Input menu. This allows you to select what type of sensor will be used with the STA unit.

If the Password Security is set to *Full Access*, the password sub-menu is bypassed, and the "CONFIG INPUT" menu is accessed by pressing *SELECT* from the View menu.

1. From the "CONFIG INPUT" display, press *SELECT*.
2. At "INPUT TYPE" press *SELECT*. Use the *UP* or *DOWN* arrow buttons to select from "CURNT or VOLTS", for input type. The default configuration is "CURNT".
3. When the display shows the type of input that you choose to use, press *SELECT*.
4. Next, the "INPUT ZERO" appears. Press *SELECT* and use the *UP* or *DOWN* buttons to define the input range. Press *SELECT* when correct value has been displayed.



Warning: For HIGH LEVEL INPUT, the Lower Range Value (LRV) must be set higher than zero. If set to zero, Broken Wire Detection will be disabled and the safety function is invalidated

5. Next, the "INPUT FULL" appears. Press *SELECT* and use the *UP* or *DOWN* buttons to define the input range. Press *SELECT* when correct value has been displayed.



Note: Broken Wire Detection "BWIRE" can only be set if the Lower Range Value (LRV) is set higher than zero (refer to the "INPUT ZERO" step 4).



Warning: The factory default for Broken Wire Detection level ("BWIRE") is zero, which disables this feature. Both the input LRV and "BWIRE" must be set greater than zero to enable Broken Wire Detection.

6. Next, the "INPUT OOR" (OOR = Out Of Range) appears. Press *SELECT* and use the *UP* or *DOWN* buttons to select from "INPUT ZERO, INPUT FULL, or EXIT OOR". Once selecting "INPUT ZERO, or INPUT FULL" press *SELECT* and use the *UP* or *DOWN* buttons to define the value. Press *SELECT* when correct value has been displayed. EXIT OOR will appear after percentage for INPUT FULL is selected, press *SELECT* to exit.
7. Next, the "BWIRE LEVEL" appears. Press *SELECT* and use the *UP* or *DOWN* buttons to define the point at which broken wire error will be activated. Press *SELECT* when correct value has been displayed.



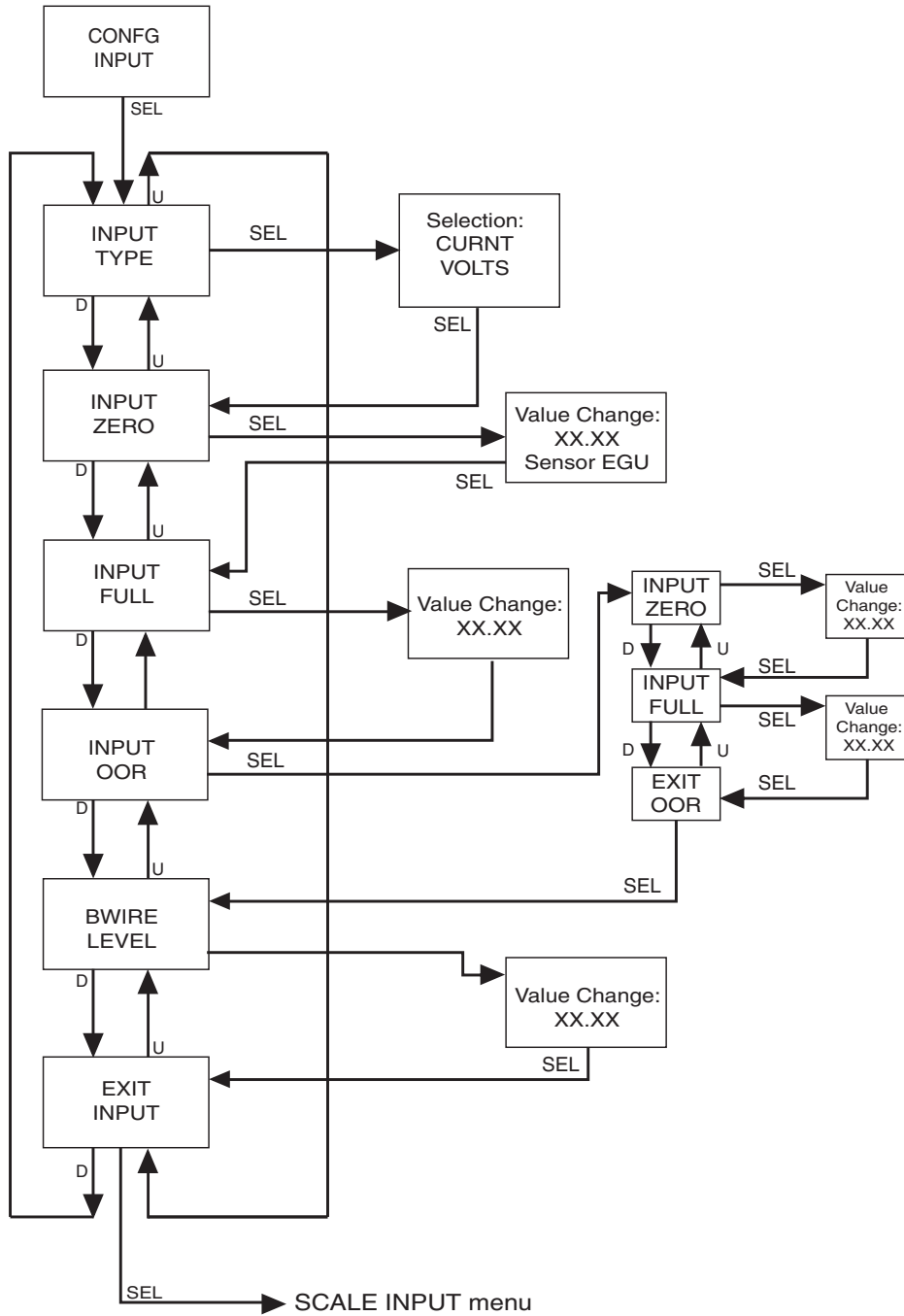
Warning: The default value for INPUT OOR is 3.84mA (lower); 20.16mA (upper). For safety applications, the INPUT OOR value must be set to 3.68mA (lower); 20.32mA (upper) or less.



Note: For STA units with firmware versions 1.5 and earlier, OOR is not configurable and the value is set to 1%.

8. "EXIT INPUT" appears. If all values in this parameter have been set, press *SELECT*. If not, return to the menu and set your values.
9. The next display is the "SCALE INPUT" menu. To skip the rest of the configuration menus and return to the process variable display, press the *UP* or *DOWN* button until you reach "CONFIG EXIT", and press *SELECT*. Refer to "CONFIG EXIT" section of this manual for more information.

Figure 4.3. CONFIG INPUT Menu



Scaling the Input

Figure 4.4 gives an overview of the Input Scaling menu.

Scaling allows you to take your PV (Process Variable) reading and transform it to a custom engineering units range. PV is the unit read after selecting your input type. For example, choosing a volts input would then produce a PV displayed in volts.

Also known as “Smart Ranging”, scaling of the STA allows you to set the zero and full scale values of the input from the intended application, without having to connect the unit to any calibration equipment.

1. At the “SCALE INPUT” display, press *SELECT*.
2. “SCALE MODE” appears; press *SELECT*. Choose whether or not to enable scaling. This will be configured in the next menu. Select “SCALE ON” and press *SELECT*.

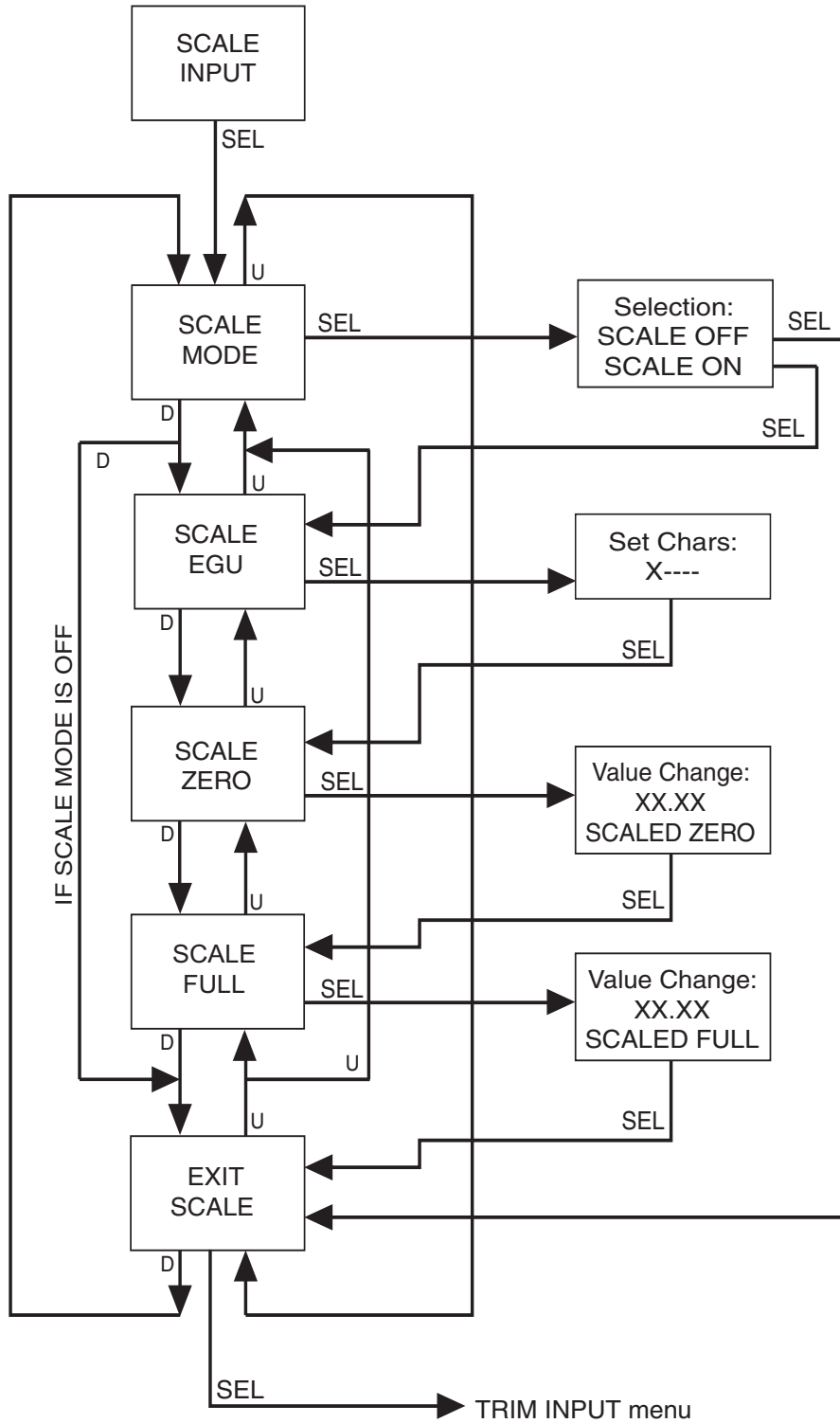


Note: If you selected “SCALE OFF” in the “SCALE MODE” menu, the menu skips to Step 6. If you selected “SCALE ON”, proceed to Step 3.

Scale Mode– This allows you to customize your display for your application. For example, if your process is sending a 6mA-17mA reading to the STA and you wish to view the input as 0-100% then this can be accomplished with the Scale Mode feature.

3. The “SCALE EGU” prompt is brought up. Press *SELECT* and choose the desired five character string to be displayed. While editing the string, the current position being edited will be alternated with a “^” character. Use the *UP* and *DOWN* button to select the correct character. Pressing *SELECT* will move to the next position.
4. Next, “SCALE ZERO” is displayed. Use the *UP* and *DOWN* buttons to adjust your scaled zero value. This is the value that will be displayed when you are at the zero end of the input range. Press *SELECT*.
5. “SCALE FULL” appears. Press *SELECT* to enter the menu. Enter the value you wish as your full scaled range. This value will appear when you are at the full end of your range. Press *SELECT*.
6. “EXIT SCALE” appears. If all scaling parameters have been set, press *SELECT*. The next menu selection to appear is “TRIM INPUT”.

Figure 4.4. SCALE INPUT Menu



Input Trimming

Figure 4.5 gives an overview of the Input Trimming menu.

Input trimming increases the measurement accuracy of your instrument by matching the reading of its actual input to its scaling. The STA offers the use of a factory-configured trimming feature ("FCTRY TRIM") or user-set, one-point or two-point ("USER 1 PNT" OR "USER 2 PNT") trimming.

Unit default is "FCTRY TRIM". If another trimming selection had been made and you wish to return to the "FCTRY TRIM" feature follow the instructions below.

1. Press *SELECT* at the "TRIM INPUT" screen. Once "TRIM MODE" appears, press *SELECT*.
2. Use the *UP* or *DOWN* buttons to reach the "FCTRY TRIM" display, and then press *SELECT*. This takes you to the "EXIT TRIM" screen.
3. To exit, press *SELECT*. Proceed to the "ALARM CONFIG" menu

To input user-specific trim values, perform the following steps: Refer to Figure 2.1 for set up and Table 2.1 for necessary equipment.

1. At the "TRIM INPUT" display, press *SELECT*. When "TRIM MODE" appears, press *SELECT* again. Use the *UP* or *DOWN* buttons to reach the user-set trimming menus. Press *SELECT* once the desired parameter is displayed— "USER 1 PNT" or "USER 2 PNT".
2. "RESET TRIM" appears, press *SELECT*. Use the *UP* or *DOWN* buttons to the desired parameter, "RESET NO?" or "RESET YES?". Select "RESET YES?" to clear previous trimming adjustment values, or "RESET NO?" to keep them.

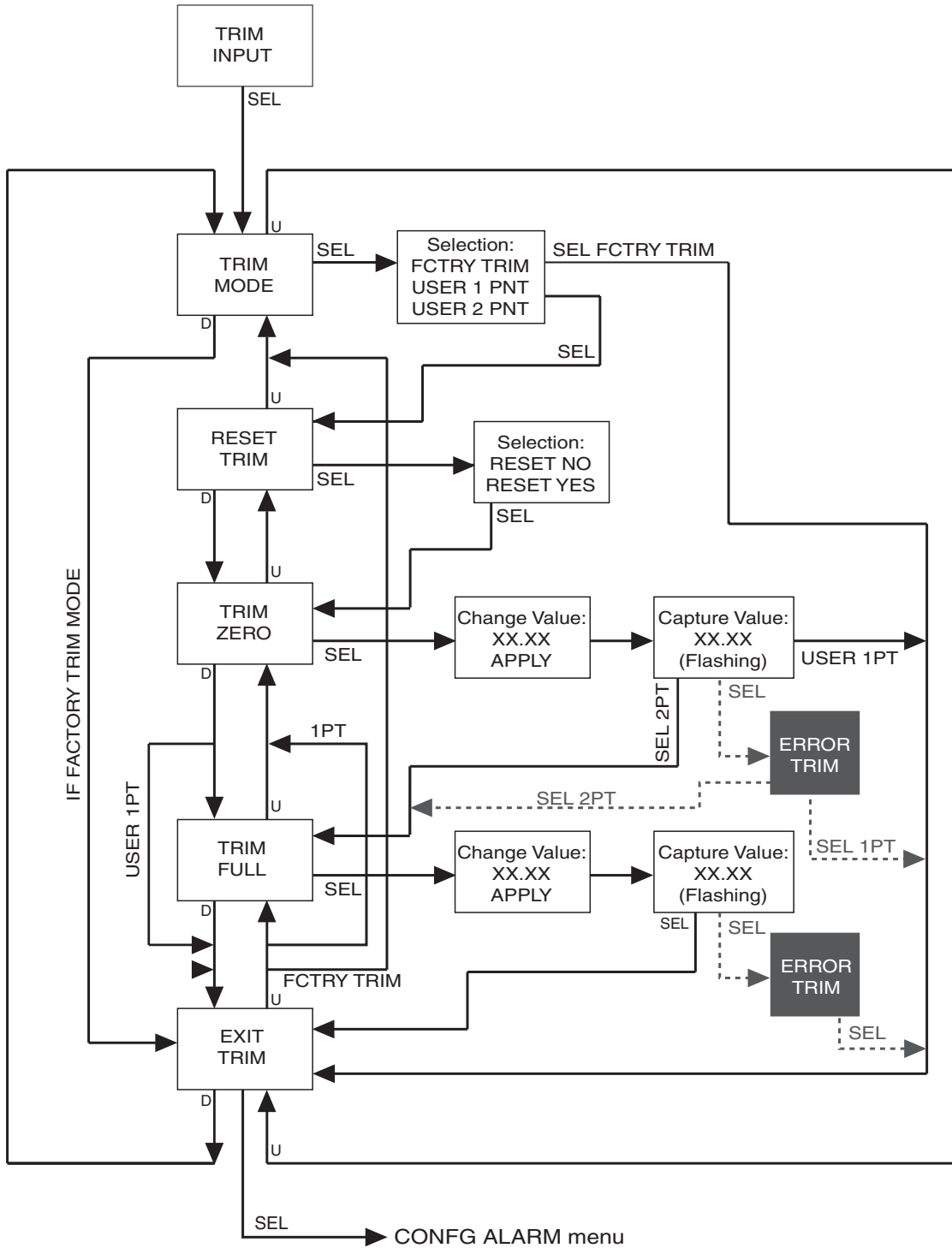
Resetting will keep trimming enabled, however no adjustment will be made to the input value. If the input is about to be trimmed, then this step is unnecessary

3. "TRIM ZERO" appears. To program, press *SELECT*. Your present zero-scale trimming value is shown, use the *UP* and *DOWN* buttons to change value, to "APPLY" your value; press *SELECT*. Once your value is present and flashing, press *SELECT* again. If you selected "USER 1 PNT" trimming, "EXIT TRIM" appears. Press *SELECT* to reach the "CONFIG ALARM" menu. Proceed to Step 4 for "USER 2 PNT" trimming.
4. If you selected "USER 2 PNT" trimming, repeat the instructions in Step 2 for the "TRIM FULL" setting. Press *SELECT* when "EXIT TRIM" is displayed to reach the "CONFIG ALARM" menu.



Note: In the event that captured values for TRIM ZERO and/or TRIM FULL are incorrect, ERROR TRIM will be displayed after values are applied. Press *SELECT* to exit ERROR TRIM, which will prompt EXIT TRIM. Use the *UP* or *DOWN* buttons to return to TRIM ZERO and/or TRIM FULL to make changes needed.

Figure 4.5. TRIM INPUT Menu



Configuring the Alarm(s)

The STA has one relay which is a Fault alarm and two user-configurable Trip alarms. The Fault alarm has limited configuration with respect to input faults only. All diagnostic faults will be latched and must be reset by cycling power to the unit. Input faults can be configured to be latched/unlatched and can also be configured to be reset by the Manual Reset (MR) in addition to front panel reset.

For more information about trip points, latching, etc., please reference the Alarm Terminology section of this manual.

1. At the "CONFIG ALARM" menu, press *SELECT*. Use the *UP* or *DOWN* buttons to toggle between both trip alarms. When the desired alarm appears, press *SELECT*.
2. At "ENTER TRIP", press *SELECT* and enter your alarm trip value. Use the *UP* or *DOWN* buttons to set, adjust your trip value; press *SELECT*.

If you prefer to capture the input trip value instead of entering it, you must use the "INPUT TRIP" menu. To do so, bypass the "ENTER TRIP" menu by using the *DOWN* button to scroll to the menu; press *SELECT*. Ensure that the value you wish to capture is present then press *SELECT*.

3. Press *SELECT* at "ENTER DB" and enter your dead band value using the *UP* or *DOWN* buttons. Press *SELECT* once your desired setting appears.
4. Pressing *SELECT* at the "SET HI/LO" menu directs you to configure the alarm type as an "ALARM HI" or "ALARM LO". Use the *UP* or *DOWN* buttons to reach your selection and press *SELECT*.

ALARM LO– You are notified if your process input drops below your trip point setting.

ALARM HI– You are notified if your process input exceeds your trip point setting.

5. At the "SET LATCH" display, press *SELECT* and choose "LATCH ON" or "LATCH OFF" using the *UP* or *DOWN* buttons; press *SELECT*.

Latching Alarm– When a STA is configured with latching alarms, an alarm condition will not "clear" (the relay will not change state) until the input returns to a non-alarm level **AND** manual reset terminals are shorted.

The manual reset terminals, labeled "MR" are located on the top row of terminals on the STA (see Figure 3.3.).

6. At the "ENTER DELAY" display, press *SELECT*. Using the *UP* or *DOWN* buttons enter the desired value (range is 0-120 seconds); press *SELECT*.

Delay– When your unit is in an alarm condition, the delay is the amount of time you set (0-120secs; 0-60secs for firmware versions 1.1.2 and earlier) to elapse before a relay trips.



Note: *Firmware versions 1.1.2 and earlier permit 0-60 seconds time delay only. If a delay value is entered greater than 60, the delay will not operate correctly. (The firmware revision of the unit is displayed at power up and in the STA Device Info window of the PC Configuration Software).*

7. If you are to program Alarm 2, use the *UP* or *DOWN* buttons to reach "CONFIG ALRM2" and repeat the steps performed from Alarm 1 using the appropriate values and settings.
8. At the "INPUT FAULT" display, press *SELECT*, this will display "LATCH YES?" to set latch press *SELECT* or press *DOWN* button to display "LATCH NO?", press *SELECT* here if you want to disable latching.

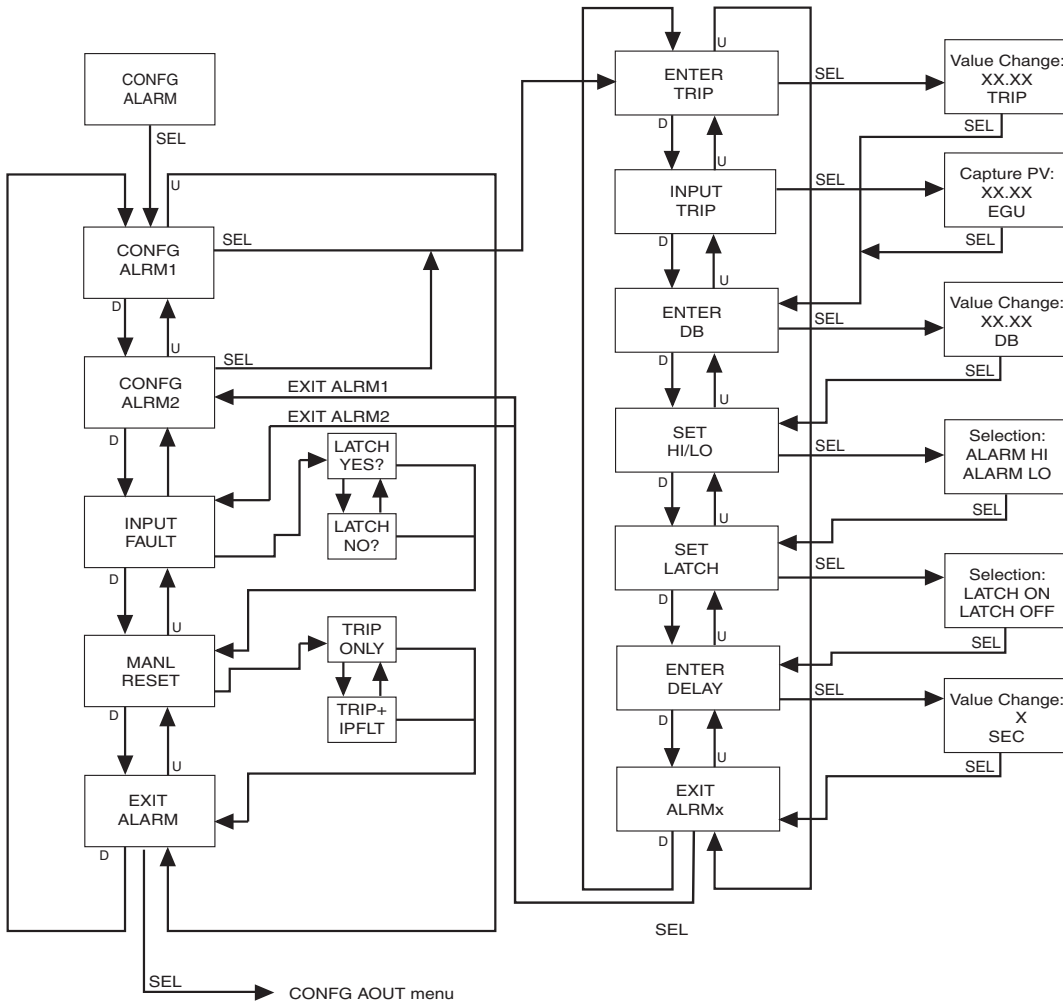
- At the "MANL RESET" display, press *SELECT*, this will display "TRIP ONLY" to set this mode press *SELECT* or press *DOWN* button to come to "TRIP+ IPFLT", press *SELECT* here if you want to make this your selection.



Note: For STA units with firmware versions 1.5 and earlier, the INPUT FAULT and MANL RESET options are not present. The fault alarm is always latched and cannot be reset by MR.

- Press *SELECT* when "EXIT ALARM" is displayed to reach the "CONFIG AOUT" menu.

Figure 4.6. CONFIG ALARM Menu



Configuring the Analog Output (-AO Option)

Figure 4.7 gives an overview of the Analog Output Configuration menu.

If your unit is equipped with the -AO option, use this menu for configuration.

1. Press **SELECT** at the "CONFIG AOUT" display. This sends you to the "SELAOUT" section. Press **SELECT** and use the **UP** or **DOWN** buttons to toggle between current and voltage. When the selection you desire is displayed, press **SELECT**.
2. Once you reach the "SET DAMP" field, you may skip the damping parameter, by using the **DOWN** button to reach the next field. To set damping, proceed to Step 3.

Damping– Output damping applies filtering to slow the response of the output so that momentary input variations reduce output spikes. The time setting (0-30 seconds) defines how long it takes for the output to reach 63% of the target value.

3. To set damping, press **SELECT** at the "SET DAMP" display. Use the **UP** or **DOWN** buttons to enter a value between 0 and 30 seconds; press **SELECT**.
4. Press **SELECT** at "FAIL MODE" to configure the analog output response to an input failure. Input failures are a subset of diagnostics limited to:
 - 1) ADC Diagnostics
 - 2) Broken Wire
 - 3) Input Saturation
 - 4) Configuration / Calibration Validation.

Choose from "FAIL HIGH", "FAIL LOW" or "HOLD LAST," then press **SELECT**. This sends you to "EXIT AOUT".

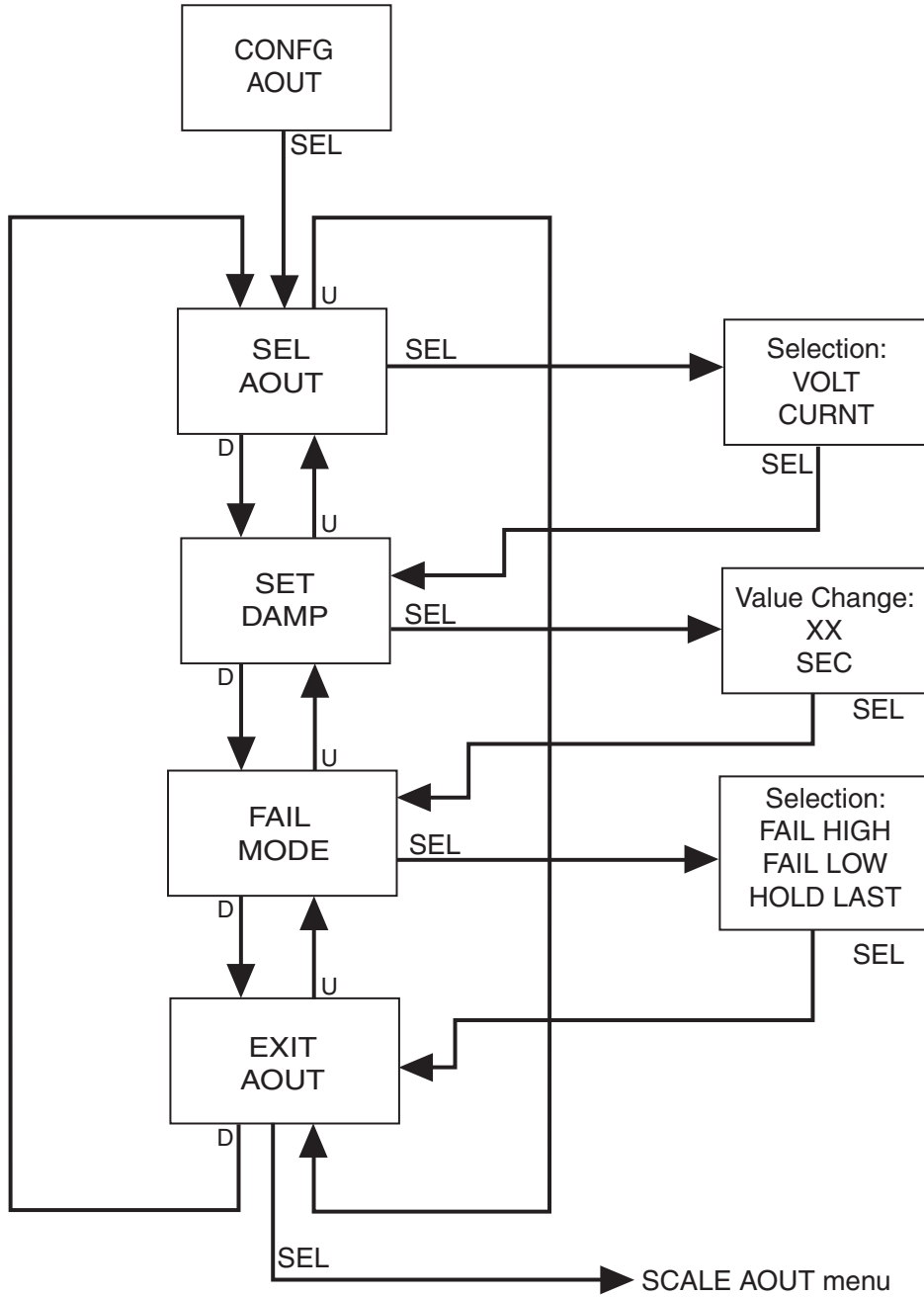
FAIL HIGH/FAIL LOW– either of these options will send the analog output to a High or Low (see Specifications table), respectively.

HOLD LAST– This will cause the analog output to maintain the last valid value present before the failure.



Note: The AO must be set to fail low if used in a safety system - please refer to section 7 for more information

Figure 4.7. CONFIG AOUT Menu



Scaling the Analog Output (-AO Option)

Figure 4.8 gives an overview of the Analog Output Scaling menu.

Follow these instructions to scale the analog output after you have performed the configuration.



Note: When using the front panel pushbuttons to enter your scaling values, you may enter only values to two decimal places (hundredths).

1. At the "SCALE AOUT" display, press *SELECT*.
2. Press *SELECT* at the "AOUT ZERO" parameter and enter the value you want to output when your input is at zero. Select from 0.00 to 21.6mA or -0.20 to 10.5V (default is 4mA or 0V) then press *SELECT*.



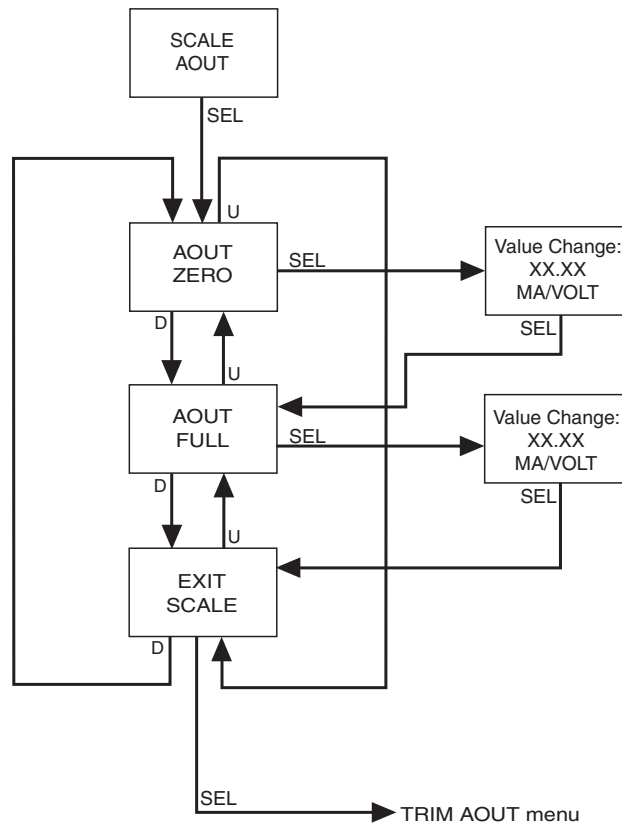
WARNING: The Analog Output Zero must be set to 4mA for a safety function.

3. Press *SELECT* at the "AOUT FULL" screen. Enter the value you want to output when your input is at full scale. Select from 0.00 to 21.6mA or -0.20 to 10.5V (default is 20mA or 10V) then press *SELECT*.
4. "EXIT SCALE" appears. If all scaling parameters have been set, press *SELECT*.



Note: Analog Output can be reversed, in which case the Zero value will be greater than the Full value. In either case there needs to be a minimum Span of 4mA or 1V.

Figure 4.8. SCALE AOUT Menu



Trimming the Analog Output (-AO Option)

Figure 4.9 gives an overview of the Analog Output Trimming menu.

Output trimming increases the measurement accuracy of the STA by calibrating its analog output to the device that is receiving the output. This ensures that the instrument is being correctly interpreted.

Connect the unit as shown in Figure 4.10 and allow five minutes for warm up and stabilization.

1. At the "TRIM AOUT" display, press *SELECT*.
2. "TRIM ZERO" appears. Press *SELECT*. The value 0.00 (mA or V depending on the set up) is shown. While monitoring your reading on the meter, use the *UP* and *DOWN* buttons to adjust the output to the desired level. Use the meter in the set up to monitor the output as it is adjusted. Press *SELECT* when the output is set as desired.



Note: The value on the LCD is an adjustment to the AOUT ZERO or FULL value. This adjustment is limited to 10% of span.

3. Press *SELECT* at "TRIM FULL" and repeat Step 2. Press *SELECT*. "FCTRY TRIM" is shown on the display.
4. If you wish to **reset** the user-configured trimming values and use factory trimming, press *SELECT* at the "FCTRY TRIM" screen. Use the *UP* and *DOWN* buttons to choose "YES"; press *SELECT*. "TEST AOUT" is brought up on the display.
By selecting "NO" at the "FCTRY TRIM" screen, the user-configured trim values will be used.
5. In order to check output performance and accuracy, you may want to perform an output test. If you choose to enable this test, follow the instructions in Step 6. To bypass this feature, use the *DOWN* button and scroll to "EXIT TRIM".
6. To enable the analog output test, press *SELECT* at the "TEST AOUT" display. Use the *UP* and *DOWN* buttons to set your output test value and press *SELECT*. "EXIT TRIM" appears; press *SELECT*.

Figure 4.9. TRIM AOUT Menu

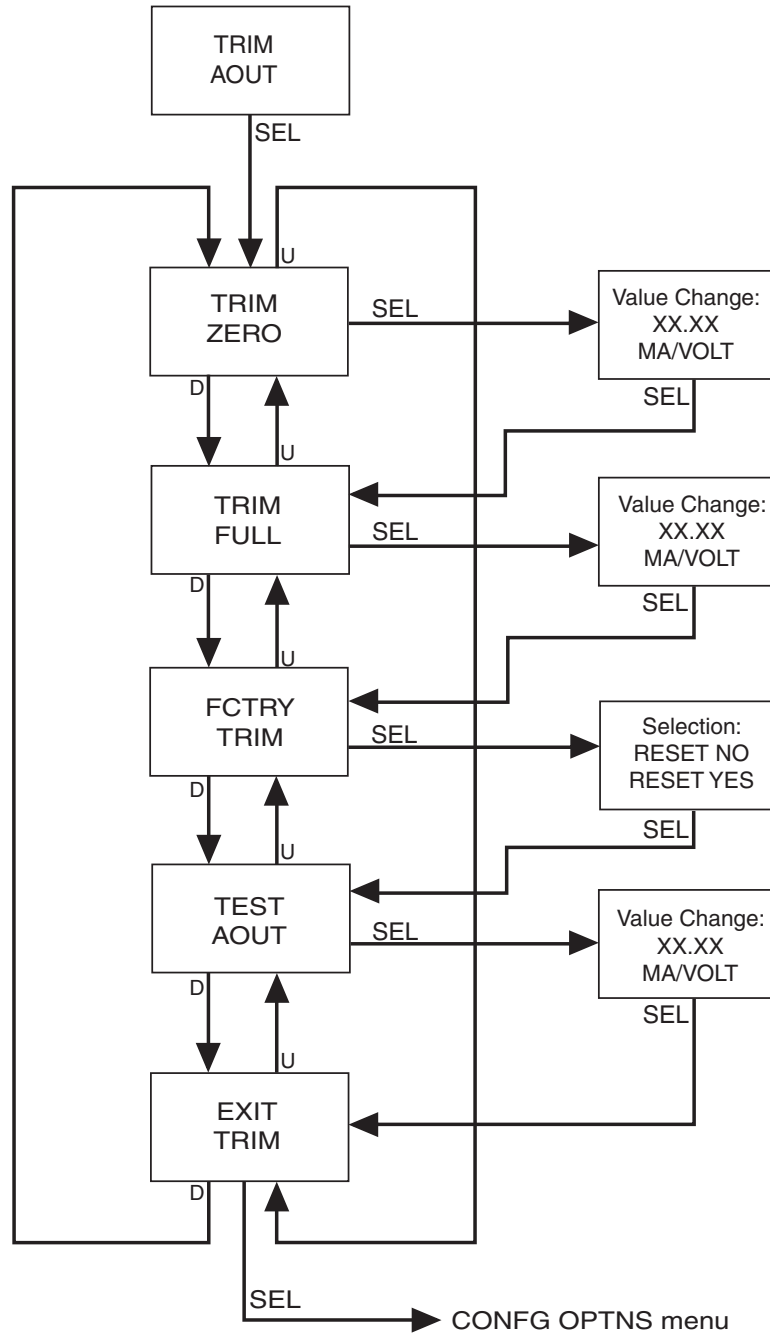
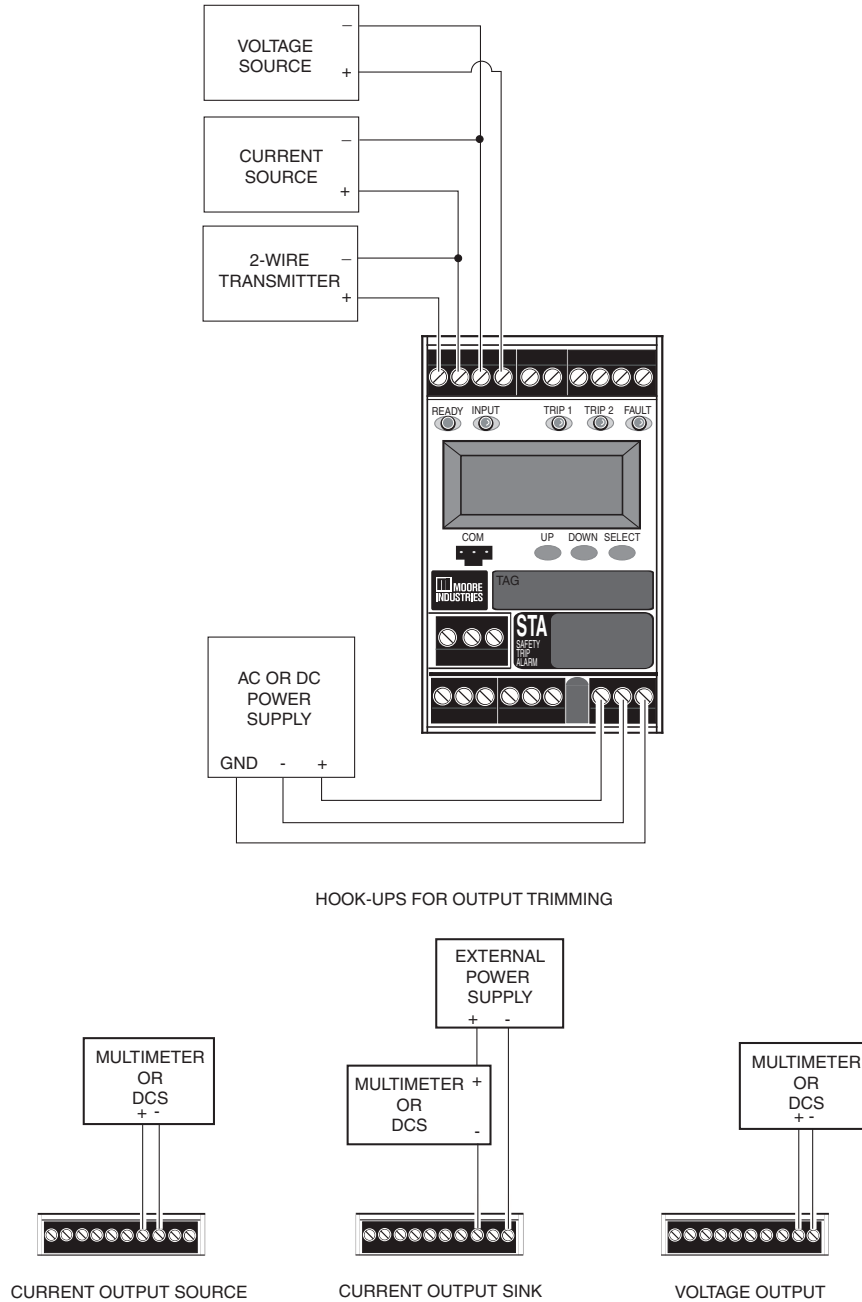


Figure 4.10. STA (TPRG) Trimming Hook-Up Diagram



Configuring the Options

Figure 4.11 gives an overview of the Options Configuration menu.

You may configure and test the display, select the 50/60Hz filter, add a startup delay and reset to factory defaults from this menu.

To configure STA options, follow the steps below.

1. At the "CONFIG OPTNS" screen, press *SELECT*.
2. "DSPLY MODE" appears. Press *SELECT* to enter the menu. Choose between "PV", "AOUT" and "PV + AOUT" by using the *UP* or *DOWN* buttons. Press *SELECT*.
3. Next, the "SET DPS" display appears. Press *SELECT*. Scroll through the available choices by using the *UP* or *DOWN* buttons and press *SELECT* once you have made your selection.
4. "SET FILTR" appears; press *SELECT*. Here, you must select the proper line frequency of your AC source—50Hz or 60Hz; press *SELECT*.
5. "START DELAY" appears; press *SELECT*. Here the desired startup delay can be entered by using the *UP* or *DOWN* buttons. This adds a delay after the STA has been initialized to allow the process input to stabilize. During initialization and delay all outputs are held in their failsafe mode. When the desired delay in seconds is displayed, press *SELECT*. START DELAY default is 0 seconds.



Note: For STA units with firmware versions 1.5 and earlier, the start up delay is not configurable and is set to 0.

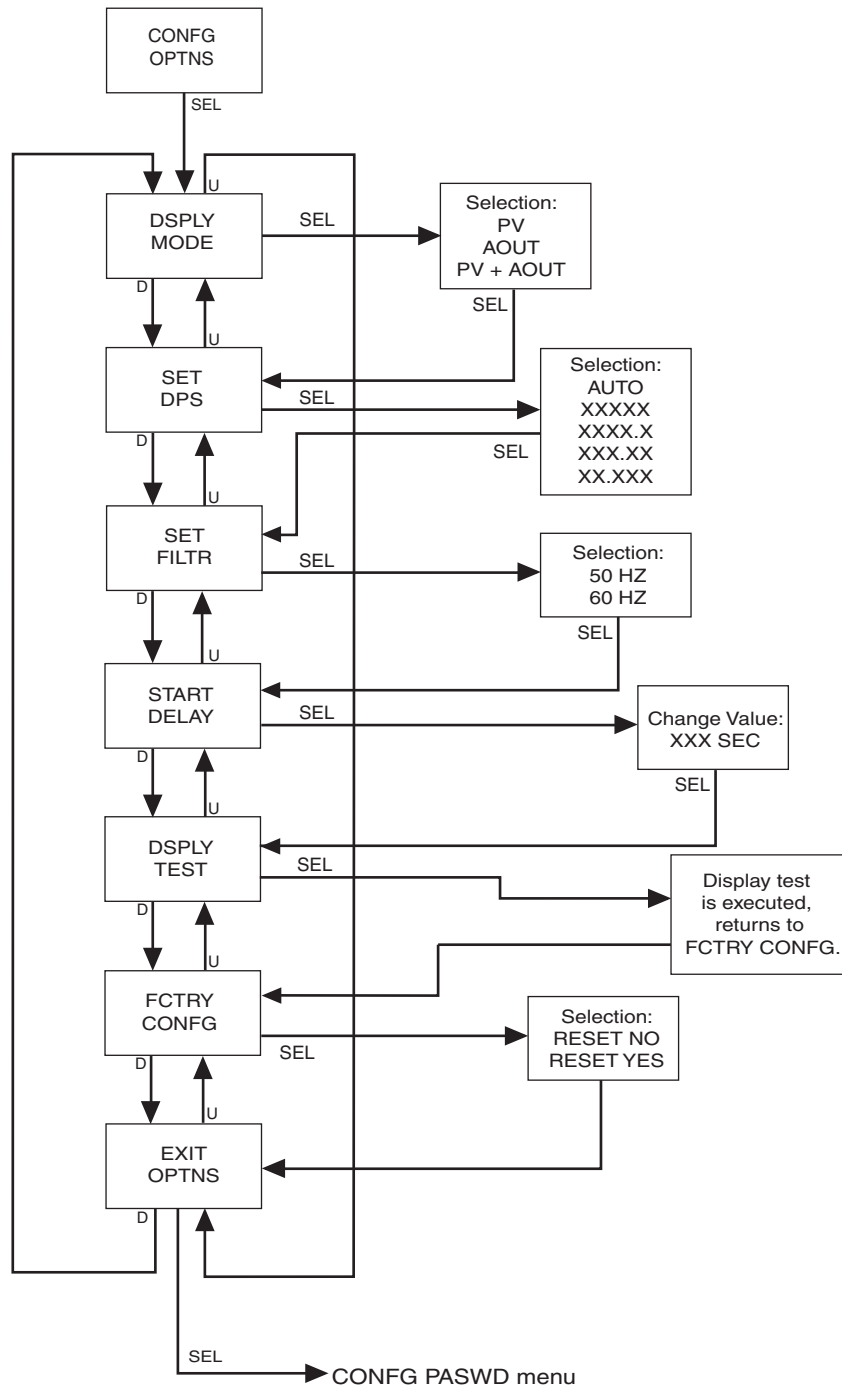
6. "DSPLY TEST" appears; press *SELECT*. Display test is executed and iterates through five different character patterns (this ensures all LCD segments function properly).
7. "FCTRY CONFG" appears. Press *SELECT* Using the *UP* or *DOWN* buttons choose between "RESET NO?" and "RESET YES?"; press *SELECT*.



Note: When resetting unit to factory default, refer to the Quick Set-Up Guide on Pg. 5 for default values.

8. "EXIT OPTNS" appears. Press *SELECT*. Proceed to the "CONFIG PASWD" menu.

Figure 4.11. CONFIG OPTNS Menu



Password Configuration

Figure 4.12 gives an overview of the Password Configuration menu.

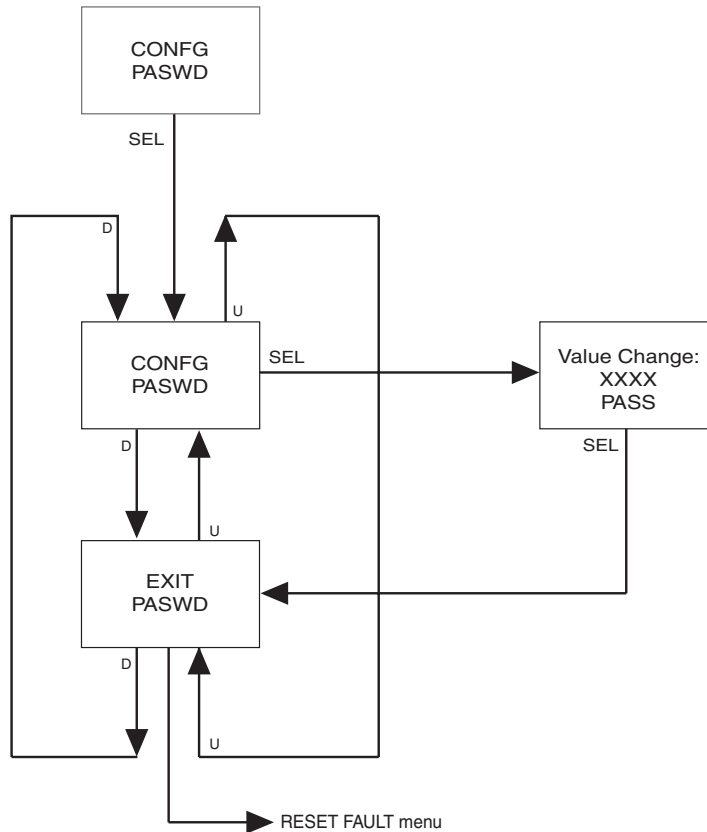
The "CONFIG PASWD" menu, is for setting a new password.

1. At "CONFIG PASWD", press *SELECT*. This puts you in the "PASS" menu. The previously saved password appears.
2. Use the *UP* and *DOWN* buttons to set a new password to any number between 0 and 9999. Press *SELECT*.
3. The "EXIT PASWD" appears. Press *SELECT*, to exit, "RESET FAULT" menu will appear.



Note: If the security is set to Full Access a password can be set but will not be requested to use and configure STA unit. Please refer to Security Settings in Section 3.

Figure 4.12. CONFIG PASWD Menu



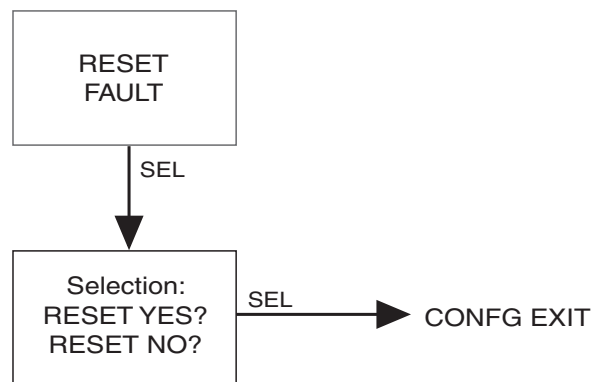
Reset Fault

Figure 4.13 gives an overview of the Reset Fault menu.

1. At "RESET FAULT", press *SELECT*.
2. Use the *UP* or *DOWN* buttons to alternate between "RESET NO?" and "RESET YES?". Press *SELECT*.
3. The "CONFIG EXIT" option appears. Press *SELECT*, to exit Main Configuration Menu or use the *UP* and *DOWN* buttons cycle through Main Configuration Menu.

RESET FAULT will clear all input related faults. If the input faults are configured to not latch, this will have no effect. All unit faults must be cleared by power cycling the unit. If a fault is still present after these steps, please contact Customer Service for further assistance. Refer to Table 6.1 for a full list of STA diagnostic messages and corrective actions.

Figure 4.13. RESET FAULT

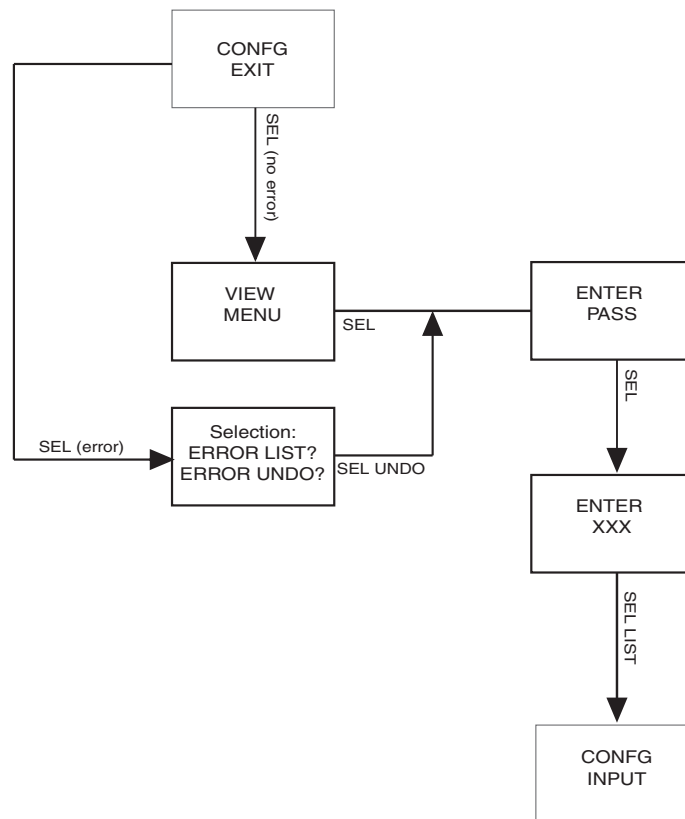


Configuration Exit

Figure 4.14 gives an overview of the Config Exit menu.

1. At "CONFIG EXIT", press *SELECT*.
2. If no error is present use the *UP* and *DOWN* buttons between "SAVE NO?" and "SAVE YES?".
3. If "SAVE NO?" is selected, you will be returned to View menu and no changes will be applied to unit (previous configuration will remain unchanged).
4. If "SAVE YES?" is selected, you will be returned to View menu and changes will be applied to unit and stored in non-volatile memory.
5. If error is present two options are available "ERROR LIST" and "ERROR UNDO". Use the *UP* and *DOWN* buttons to cycle these two options.
6. If "ERROR LIST" is selected, you see the list of configuration errors, press *SELECT* and this will return you to the Main menu to make changes where needed.
7. If "ERROR UNDO" is selected, you will be returned to View menu and no changes will be applied to unit (previous configuration will remain unchanged).

Figure 4.14. CONFIG EXIT Menu



Section 5 - STA PC Configuration



Note: Earlier versions of STA were shipped with Transfer Utility Software not PC Configuration Software. This allows you to upload/download, view and print but not change your instrument's configuration. For the latest version of PC Configuration Software, please go to www.miinet.com

Installing the Configuration Software

Refer to Table 5.1 for the equipment needed.

1. Check the Moore Industries website @ www.miinet.com for the latest software package to ensure you have the latest release. Also if you are not able to go online install software using the included *Moore Industries Interface Solution PC Configuration Software* CD. Insert CD into the CD drive of the PC. Access the CD and open the "STAPC Configuration Software" folder.
2. Double-click the installation program located in the folder. Follow the prompts to correctly install the program.

Once the Configuration Program is installed onto your PC, the STA can be connected to equipment to simulate input and monitor output. You can then change the operating parameters of the alarm.

No Unit Needed

It is not necessary to connect the STA to a PC to create configuration files using the software. The Configuration Program can be run without connecting an STA, and **most** parameters can be set without the benefit of an input from a sensor or STA.

This makes it easy to create a set of operating parameters, save them to disk, and download them to one or more instruments at a later time.

The STA **must** be connected to the PC in order to: trim input, trim output, assign a tag, perform a loop test, receive (via download) a configuration file, and save the configuration file (via upload) from the STA's memory.

Selecting Model Type

User must select model type and Firmware version when the software is opened without a unit connected as shown below. Unit type is determined by Input Type and Analog Output Configuration and firmware Rev, additional features added if firmware is v1.6 or greater. When a unit is connected the software will select the correct type automatically.

Connecting the STA to the PC

Connect the RS-232 or USB end of the cable to the PC's COM/USB port. .

See Table 5.1 for information on the necessary equipment.

PC Software Configuration

One of the benefits of the STA is that you may either use the external push button controls to set up the instrument, or with Moore Industries' Intelligent PC Configuration software on your PC.

When using the software program, settings are downloaded to the instrument in the form of a Configuration File and stored in the instrument's memory. You can save a backup copy of the file on your PC hard drive or disk. The STA communicates with the PC through an RS-232 connection or USB Communications Cable.



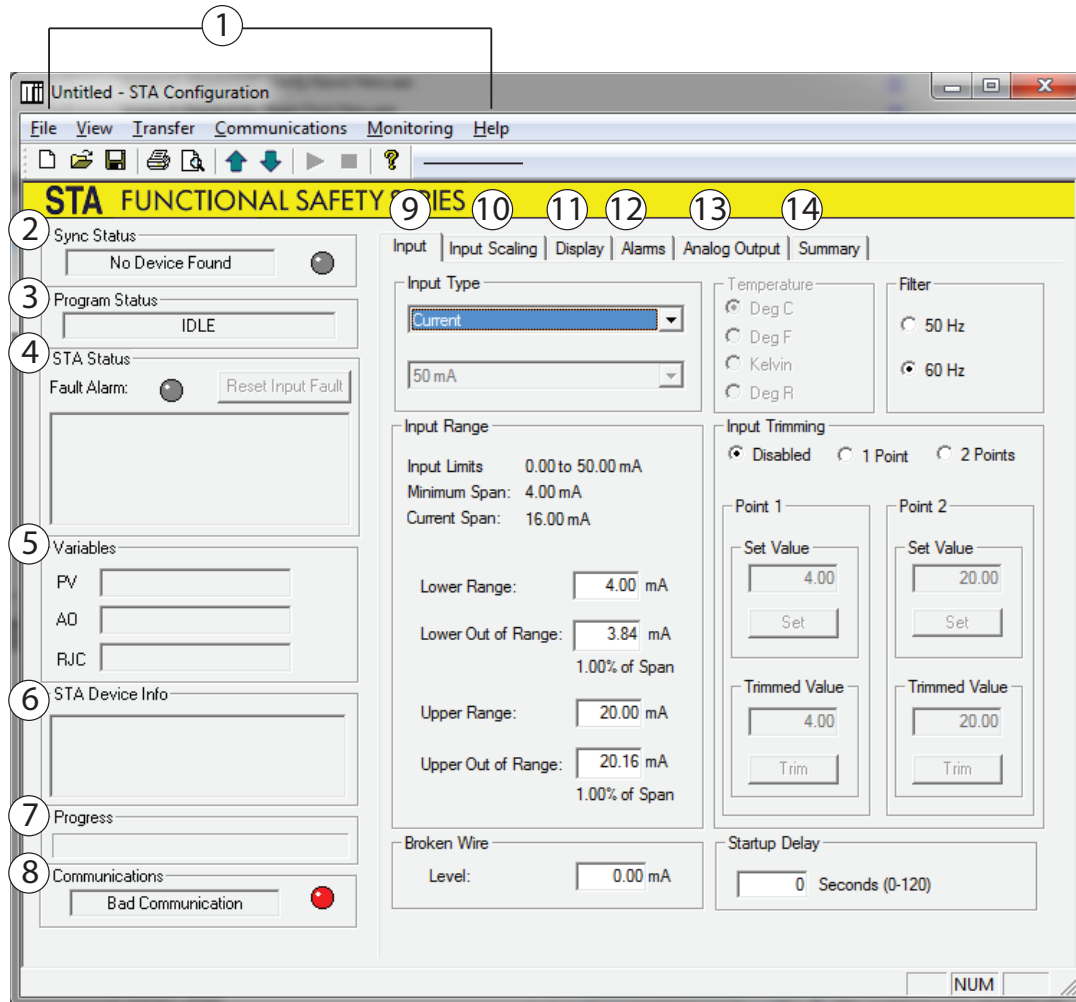
Note: Refer to the *STA HLPRG Quick-Start Guide* to see the default factory settings for your unit.



Caution: *Unplugging the programming cable or resetting power while downloading to the unit could result in a default configuration / calibration and the unit may have to be returned to the factory.*

Table 5.1. Necessary Equipment to Install STA Configuration Software

Device	Specifications
Variable Input Simulator for Current or Voltage	Variable; Accurate to $\pm 0.05\%$ of unit span
Power Supply	21.6-375Vdc or 90-260Vac (depending on model)
Multimeter (optional)	Accurate to $\pm 0.009\%$ of span; e.g., HP Model 3478A
Personal Computer	Microsoft Windows based PC; 16Mb free RAM; 20MB free disk space on hard drive Microsoft Windows XP, 7 or 10 1 (one) serial port or one USB port (with optional cable)
Moore Industries PC Configuration Software	Version 2.0 or greater, successfully installed to the hard drive
Communication Cable	Part# Communications Cable 803-053-26A or USB Cable Part# 804-030-26A



The PC Software is made up of these sections:

1. Menu and Tool Bar Dropdown menus and corresponding icons allow you to perform various functions throughout the PC Configuration Program. Refer to the *Menu and Tool Bar Legend* for a complete description.

2. Sync Status– This displays whether or not unit configuration and software configuration are currently in Sync (match). It will display the following messages:

- In Sync (green light)
- Out of Sync (yellow light)
- No Device (grey light).

3. Program Status– This portion of the program displays the activity of the connected unit. It will display such messages as: Reading STA Info, Idle, Monitoring Variables and Monitor Fail.

4. STA Status– Includes Fault Alarm Status indicator, “Reset Input Fault” button and displays the problems or faults with the instrument:

- Fault Alarm on STA not tripped (green light)
- Fault Alarm on STA tripped (red light)



Note: The STA Status indicator and Status LED are updated whenever the user clicks download, upload, or “Reset Input Fault” as well during monitoring mode.

The “Reset Input Fault” button can be used to reset the latched FAULT alarm and relay if the fault was generated by an input diagnostic. If the input error is not cleared when resetting the fault alarm, the error condition will immediately be re-applied and will not cause the relay to glitch.



Note: The Fault Alarm trips on internal, input and user configuration diagnostics. User configuration faults will clear automatically once the configuration is valid. Input faults can be cleared by pressing the “Reset Input Fault” button, MR Terminals (if configured), or by power cycling the unit. Internal faults require the unit to be power cycled and will not be cleared by this button. See STA Diagnostics & Fault Alarms in Section 6 for more information.



Note: The “Reset Input Fault” is disabled when there is no unit connected.

5. Variables (PV, AO, and RJC)– Displays the selected Process Variable, Analog Output and Reference Junction Compensation value.

6. STA Device Info– This displays instrument configuration, device identification, hardware revision and software revision.

7. Progress Bar– This bar stays in motion any time the STA is monitoring, uploading, or downloading.

8. Communications– Notifies user of current PC connection/communications status.

9. Input Tab– Use this tab to set your input parameters. Refer to the *Input* section for a complete description.

10. Input Scaling Tab– If you choose to enable the scaling feature, the parameter would be configured at this window and to set a Custom EGU. Refer to the *Scaling* section for a complete description.

11. Display Tab– Used to set up the appearance of the STA’s LCD screen. Refer to the *Display* section for a complete description.

12. Alarms Tab– Alarm parameters are configured using these windows. Refer to the *Alarms* section for a complete description.

13. Analog Output Tab– Configuration of the analog output (if your instrument is equipped with the -AO option) is performed here. Refer to the *Analog Output* section for a complete description.










14. Summary Tab– Displays the Data Source, Model and all Configuration parameters for Input Type, Trimming, Scaling, Display Settings, Alarm Settings, and Analog Output Settings in a summarized format.




Note: When user opens a Saved file and alters the displayed configuration a [modified] tag will be displayed before both the File Title and in the Data Source section of the Summary Tab. Once you Save the File after modifications the [modified] tag will disappear. Note this does not update the unit this only updates the file being saved. To apply modifications to the unit the user must download the file to unit.

Note: When user uploads a configuration from unit and then alters the displayed configuration a [modified] tag will be displayed before the Device Tag in Summary Tab. Once you download the configuration to the unit the [modified] tag will disappear.

Menu and Tool Bar Legend

		Allows New, Open, Save and Print functions
		Controls whether Tool and Status Bars are viewed on the screen
		Allows you to Upload and Download configurations
		Allows selection of PC Port (Com Port) to be used
		Allows you to Monitor and Stop monitoring processes
		Displays the version of the STA Configuration Program

PC Configuration Software Monitoring

To start monitoring the STA click on the  icon or click Monitor from the Monitoring Menu. When the software enters monitoring mode the software switches to the Summary Tab. In the Summary the last uploaded configuration from the device will be displayed.



Note: Changes that have been made and not downloaded to the unit will be discarded.

While the unit is in monitoring mode the STA Status Section and Variables Section will be continuously updated. This includes the PV and AO (only applicable if unit has AO).

In order to stop Monitoring Mode, click on the  icon or click Stop in the Monitoring Menu. This will stop monitoring.

Using PC Configuration Software Offline

When using the STA PC Configuration without a unit connected or properly communicating with software (offline) it is important to know that the following items will be greyed out and disabled from making changes.

Input Tab:

Input Trimming: Set and Trim buttons are disabled.

Analog Output Tab:

Trimming: The Zero, Full, Trim, Unfix and the Reset to factory "Reset" buttons are disabled.

Output Test: Fix and Unfix buttons are disabled

The left panel section (Sync Status, Program Status, etc.) can be disregarded, these sections are only updated if a unit is connected. The "Reset Input Fault" is also disabled..



Note: The configuration software will enter offline mode if there is no unit connected upon startup, it will also enter offline mode if there is a failed upload or download.



Note: While in offline mode the user can save Input Trimming mode and set points to a file. To use these settings simply open file while unit is connection and download saved configuration file to unit.



Note: Unless otherwise noted, ensure that the PC Program is idle before making any selections or configuration changes to the parameters and windows of the program. Also, when attempting to download, or upload, monitoring must be stopped. To do this, click "Stop" in the Monitoring dropdown menu, or click the "Stop Monitoring" icon.

Input

Figure 5.1. Input Tab

The screenshot shows the 'Input' configuration tab of the STA HLPRG software. It features several sections: 'Input Type' with a dropdown set to 'Current' and a value of '50 mA'; 'Temperature' with radio buttons for 'Deg C', 'Deg F', 'Kelvin', and 'Deg R'; 'Filter' with radio buttons for '50 Hz' and '60 Hz'; 'Input Range' with 'Input Limits' (0.00 to 50.00 mA), 'Minimum Span' (4.00 mA), 'Current Span' (16.00 mA), and fields for 'Lower Range' (4.00 mA), 'Lower Out of Range' (3.84 mA, 1.00% of Span), 'Upper Range' (20.00 mA), and 'Upper Out of Range' (20.16 mA, 1.00% of Span); 'Input Trimming' with radio buttons for 'Disabled', '1 Point', and '2 Points', and sub-sections for 'Point 1' and 'Point 2' each containing 'Set Value' and 'Trimmed Value' fields with 'Set' and 'Trim' buttons; 'Broken Wire' with a 'Level' field set to '0.00 mA'; and 'Startup Delay' with a field set to '0' seconds (range 0-120).

Input Type– Select your input type.

Filter– This setting is used to configure the input filter. This filter is designed to reduce the effects of mains-induced noise. The input filter frequency value should be set to the frequency of the local AC supply– either 50Hz or 60Hz.

Input Range– Allows you to set your Input Zero and Full range values within the range chosen in the *Input Type* section.

The desired Input Zero and Full range values can be entered via your PC keyboard.



Warning: The default value for INPUT OOR is 3.84mA-20.16mA for Current Input Type (1%). For safety applications, the INPUT OOR value must be set to 3.68mA-20.32mA (2%) or less.



Note: Entered Values must be within the displayed Input Limits. Minimum Span is also displayed and Span between entered values must conform to this minimum value. Refer to Table 9.4 for Input Limits and Minimum Span for each specific Input Type.



Note: The actual value must be entered in the Out Of Range fields, percentage is automatically displayed below this field. Values entered in the Out Of Range fields for the Input Full and Input Zero are limited 0% to 5 % of the Span. Span is displayed above along with Sensor Limits and Minimum Span.

Note: For STA units with firmware versions 1.5 and earlier, OOR is not configurable and the value is set to 1%.

Broken Wire– The Broken Wire feature is can be used to set the input level of Broken wire. This input level must be less than or equal to the Input Zero.



Note: Broken Wire Detection “BWIRE” can only be set if the Lower Range Value (LRV) is set higher than zero (refer to the “INPUT ZERO” step 4).



Warning: The factory default for Broken Wire Detection level (“BWIRE”) is zero, which disables this feature. Both the input LRV and “BWIRE” must be set greater than zero to enable Broken Wire Detection.

Input Trimming– Input Trimming increases the measurement accuracy of your instrument by matching the reading of its actual input, to either a calibrated source or the device to which it is connected. This verifies that the input to the transmitter is being interpreted correctly.

You may trim any point between 0% and 100% along the scale. Note that one-point trimming applies an offset to the input reading, while two-point trimming applies both an offset and a gain. Refer to Figure 2.2 for set up and Table 2.1 for necessary equipment.

Follow the steps below in order to perform input trimming.

1. Select either “1 Point” (one-point trimming) or “2 Points” (two-point trimming) by clicking the appropriate button. Each pair consists of “Set Value” and “Trim” fields.
2. Enter the values that require trimming into the “Set Value” field and click “Set”.
3. Apply the targeted signal to the input, wait until it settles, and click “Trim” to capture the measured value. If you chose “2 Points”, repeat the step above for the second point.



Note: To reset and return to Factory Trimming values simply select the Disabled Trimming radio button. Changes made to the Trimming section will immediately effect the unit. Set and trim buttons are disabled when there is no unit connected.




Warning: If either of the Set Buttons are clicked, any Input Trimming in the device will be reset and lost. Make sure that when Trimming 2 points, both values are entered and Set before any Trimming takes place.

Start Up Delay– This allows you to set a Start up Delay of 0-120 seconds (default is 0). This adds a delay after the STA has been initialized to allow the process input to stabilize. During initialization and delay all outputs are held in their failsafe mode.



Note: For STA units with firmware versions 1.5 and earlier, the start up delay is not configurable and is set to 0 secs.



Note: Once you have configured all parameters, download to the unit by selecting “Download” in the Transfer dropdown menu located in the Status Bar. Or, click the  button in the Menu Bar.

Input Scaling

Figure 5.2. Input Scaling Tab

The screenshot shows the 'Input Scaling' configuration window. It has a title bar with tabs: 'Input', 'Input Scaling', 'Display', 'Alarms', 'Analog Output', and 'Summary'. The 'Input Scaling' tab is active. Inside the window, there is a 'Scaling' section with a checked 'Enabled' checkbox. Below this, there are two columns: 'Zero' and 'Full'. Under 'Zero', there is an 'Input Range' field with '0.00' and a 'Scaled To' field with '0.00'. Under 'Full', there is an 'Input Range' field with '10.00' and a 'Scaled To' field with '100.00'. To the right of these fields is a 'Volts' label and a 'XXXXXX' field. At the bottom right, there is a checked 'Custom' checkbox.

Input Scaling– This allows you to customize your display for your application. By example: if your process is sending a 4-20mA signal to the STA and you wish to view the input as 0-100% then this can be accomplished with the Scaling feature.

To scale your instrument, perform the following steps:

1. Click the “Enabled” check box.
2. The “Sensor Range” boxes will display the range selected in the “Input Type” section of the *Input* screen.
3. In the “Process Variable” text boxes, enter the values you wish displayed when your input is at its Lower Range and Upper Range.

Once downloaded, your unit will display the scaled values on its LCD.


Custom EGU– If select you can choose to assign a specific label, or EGU (Engineering Unit).

1. Check the “Custom” box.
2. Enter the value you wish viewed into the “Custom EGU” text box.
Alpha numerical characters allowed:
A-Z, 0-9, *, +, -, /, \, >, <,



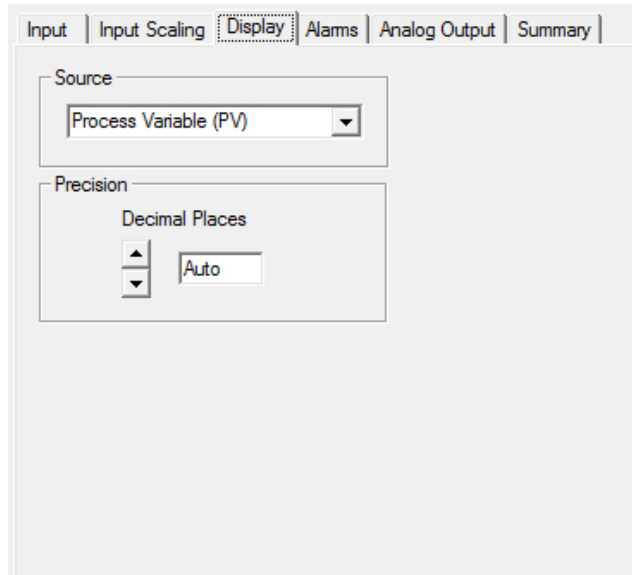
Note: Custom EGU will prompt a warning if any character entered in this field is invalid and will then set invalid that character(s) to “X”.



Note: Once you have configured all parameters, download to the unit by selecting “Download” in the Transfer dropdown menu located in the Status Bar. Or, click the  button in the Menu Bar.

Display

Figure 5.3. Display Tab




You may configure what is displayed (source) and Precision format (decimal places).

Source– Select your Source type Process Variable (PV), Analog Output Current/Voltage, or Toggle PV and AO.

Precision– Select the number of decimal places/resolution of your display (default is Auto).



Note: Once you have configured all parameters, download to the unit by selecting “Download” in the Transfer dropdown menu located in the Status Bar. Or, click the  button in the Menu Bar.

Alarms

Figure 5.4. Alarms Tab

The screenshot displays the 'Alarms' configuration window. At the top, there are tabs for 'Input', 'Input Scaling', 'Display', 'Alarms', 'Analog Output', and 'Summary'. The 'Alarms' tab is active. Below the tabs, there are four main sections: 'Alarm 1', 'Alarm 2', 'Input Fault Alarm', and 'Manual Reset'. 'Alarm 1' and 'Alarm 2' each have radio buttons for 'High Alarm' (selected) and 'Low Alarm', and a checkbox for 'Latching'. They also have input fields for 'Trip Point' (12.00 mA), 'Dead Band' (0.00 mA), and 'Delay' (0 Seconds). 'Input Fault Alarm' has a checked checkbox for 'Latching'. 'Manual Reset' has radio buttons for 'Trip Alarms 1 & 2 Only' (selected) and 'Trip Alarms 1 & 2 + Input Fault Alarm'.

The STA has one relay which is a Fault alarm and two user-configurable Trip alarms. The Fault alarm has limited configuration with respect to input faults only. All diagnostic faults will be latched and must be reset by cycling power to the unit. Input faults can be configured to be latched/unlatched and can also be configured to be reset by the Manual Reset (MR) feature in addition to front panel reset.



Note: For STA units with firmware versions 1.5 and earlier, the fault alarm has no configuration options, is always latched and cannot be reset by MR.

For more information about trip points, damping, etc., please reference the Alarm Terminology in Section 1 of this manual.

Trip Point – Set this Point to have STA unit notify you if your process input drops below, or exceeds your trip point setting depending on Alarm Mode select by user.

Dead Band– The Dead Band is the range within which an alarm relay remains in an alarm condition even after the monitored process variable input has returned to a safe level, at or below/above the trip point setting.

Delay - When your unit is in an alarm condition, the delay is the amount of time you set to elapse before a relay trips. This can be set in increments of 1 second from 0-120 seconds.




Note: Firmware versions 1.1.2 and earlier permit 0-60 seconds time delay only. If a delay value is entered greater than 60, the delay will not operate correctly. (The firmware revision of the unit is displayed at power up and in the STA Device Info window of the PC Configuration software).

Latching- By default, alarms will be unlatched. Select this to configured the STA with a latching alarm, this alarm condition will not “clear” (the relay will not change state) until the input returns to a non-alarm state **AND** manual reset terminals are shorted and then opened.

Input Fault Alarm Latching – By default, input fault alarms will be latched. Uncheck this box to remove latching. When latching feature is on and the input goes into a Fault state the Fault Alarm will remain engaged until you reset it via front panel, using the reset fault button in PC Configuration Software, or by MR (if configured). When Latching is disabled the Fault Alarm will disengage as soon as the input returns to a Non-Fault State.

Manual Reset– This Feature allows you to select which alarms will reset when the Manual Reset is engaged.



Note: Once you have configured all parameters, download to the unit by selecting “Download” in the Transfer dropdown menu located in the Menu Bar. Or, click the  button in the Menu Bar.

Analog Output

Figure 5.5. Analog Output Tab

The screenshot shows the 'Analog Output' configuration tab. It includes sections for Mode (Current/Voltage), Process Variable Range (0-10 Volts), Output Scaling (4-20 mA), Damping (Enabled/0s), Fail Mode (High/Low/Hold Last), Trimming (Zero/Full/Trim), Unfix Output, Reset to factory, and Output Test (Fix/Unfix).

The Analog Output Tab will be available if your instrument is equipped with the -AO option.

Mode– Your desired output mode; Current or Voltage.

Process Variable Range– Displays the selected process variable range in the “Measurement Mode” section of the *Input* screen.

Output Range– Sets your output limits. Set your Output Range. Enter a low and high value.

Damping– Output damping applies filtering to slow the response of the output so that momentary input variations reduce output spikes. The time setting (0-30 seconds) defines how long it takes for the output to reach 63% of the target value. Select “Enabled” if you choose to use Damping. Enter your damping time from 0-30 seconds in 0.5 second intervals into the “Damping” text box.

Fail Mode– In the case of an input failure, you have the ability to set a mode you choose to alert of the failure.


High/Low– Choosing either of these options will send the output to a High (23.6mA for current; 11.0V for voltage) or Low (3.6mA for current; -0.5V for voltage) fail mode, respectively.

Hold Last– This will display the last value present before the failure.



Note: The AO must be set to fail low if used in a safety system - please refer to Section 7 for more information



Note: Once you have configured all parameters, download to the unit by selecting “Download” in the Transfer dropdown menu located in the Status Bar. Or, click the  button in the Menu Bar.

Trimming– Output Trimming increases the accuracy of your instrument by calibrating its analog output to the device that is receiving the output. This ensures that the instrument is being correctly interpreted.

Connect the unit as shown in Figure 4.10 and allow five minutes for warm up and stabilization.

1. Connect the analog output of your instrument to an external multimeter.
2. Click the “Zero” button to trim the Fix Output at Zero.
3. To “fine tune” trimmed values, place the value read on the external multimeter (mA value for mA output mode, voltage value for voltage output mode) in the “Measured mA / V” text box and click “Trim”.
4. Click the “Full” button and repeat Step 3 to trim the Fix Output at Full.
5. Once you have performed your output trimming, click “Unfix”.



Note: The trim value is an adjustment to the AOUT ZERO or FULL value. This adjustment is limited to 10% of span.



Note: Do not click the “Reset” button in the Trimming menu unless you want to disregard your trimmed values and return to the manufacturer’s factory trim values. Changes made to the Trimming section will immediately effect the unit. Trimming buttons are disabled when there is no unit connected.

Output Test– This test may be performed in order to check output performance and accuracy and to trim other instruments in your setup. Your output will be a current value, in mA, or a voltage equal to the value you enter into the text box. You can check the other devices on the system and calibrate them to this signal.

This feature is independent of the input. If you find that the output requires adjustment, you may perform the Trimming function.

1. Ensure that STA monitoring is stopped. In the “Fix current / voltage” text box, enter a value between 0-23.8mA (for current) or -0.5 - 11V (for voltage) and click the “Fix” button.
2. Return to monitoring the STA. You will see the “fixed” value in the “AO” field in the Variables Section and on the external multimeter.
3. Once you have finished, click “Unfix”.



Note: While performing Analog Output Trimming functions, you may notice a message in the “STA Status” display reading “**Output fixed**”. Clicking the “Unfix” button will clear this message. Changes made to the Output Test section will immediately affect the unit. Output test is disabled when there is no unit connected.

Summary

Figure 5.6. Summary Tab

Input	Input Scaling	Display	Alarms	Analog Output	Summary
Data Source		Untitled			
Model		STA/HLPRG/3PRG/U/AO [DIN]			
Input		Measurement Type: Current Input Range: Zero: 4.00 mA, Full: 20.00 mA OOR Tolerance: Zero: 3.84 mA, Full: 20.16 mA Filter Settings: 60Hz Broken Wire: Disabled Startup Delay: 0 seconds			
Trimming		Disabled			
Scaling		Disabled			
Display		Display Source: Toggle PV and AO Precision (Decimal Places): Auto			
Alarms:		Alarm 1	Alarm 2		
Mode:		High trip	High trip		
Latching:		Off	Off		
Trip point:		12.00 mA	12.00 mA		
Deadband:		0.00 mA	0.00 mA		
Delay:		0 s	0 s		
Manual Reset		Trip Alarms 1 & 2 Only			
Input Fault Latching		On			
Analog Output		Mode: Current Fail Mode: Fail Low AO Range: Zero: 4.00, Full: 20.00 mA Damping: Disabled (0.0 s)			

The Summary tab displays the following Data Source, Model, Input, Trimming, Scaling, Display, Alarms, Manual Reset, Input Fault Latching, and Analog Output.

Data Source: Data Source will specify origin of configuration being displayed, this can be directly from device or from a file.



Note: When user opens a Saved file and alters the displayed configuration a [modified] tag will be displayed before both the File Title and in the Data Source section of the Summary Tab. Once you Save the File after modifications the [modified] tag will disappear. This does not update the unit this only updates the file being saved. To apply modifications to unit the user must download the file to unit.



Note: When user uploads a configuration from unit and then alters the displayed configuration a [modified] tag will be displayed before the Device Tag in Summary Tab. Once you download configuration to unit the [modified] tag will disappear.

Section 6 - Operation and Maintenance

When the STA is used in a SIL rated safety application, please refer to the Safety Instrumented Systems section of this manual before operating your unit.

Operation

Once calibrated, installed, and supplied with the correct power, the STA begins to operate immediately. Depending upon environmental conditions, it can be expected to operate unattended for extended periods of time.

STA Diagnostics & Fault Alarms

The STA has a high level of diagnostic capability to continually monitor itself and its input. This section outlines these diagnostics and functionality of the alarms. For a full list of diagnostic messages and corrective actions please refer to Table 6.1.

Internal diagnostics

On power up the unit runs through a thorough diagnostic test (RAM and ROM TEST messages are displayed), an initialization process (SYS INIT is displayed) and waits the configured amount set in the Startup Delay Menu before the fault alarm is cleared. If any failure is found during power up, the fault alarm will not be cleared and an error message will be displayed. Once in operation, the unit continues diagnostic tests in the background and will set the fault alarm on any failure.



Note: For STA units with firmware versions 1.5 and earlier, the startup delay cannot be configured and is set to 0.

All internal diagnostic faults will cause the fault relay to de-energize and remain in a latched state. Spurious faults that can be caused by external factors such as transients or surges, may result in a diagnostic failure and trigger the fault alarm. While some faults may be cleared via the menu system or MR Terminals (if configured), it is recommended that the STA be power cycled to clear the latched fault alarm. If the error persists, then please record the error message and contact MII Customer Support for further assistance.



Note: For STA units with firmware versions 1.5 and earlier, the fault alarm has no configuration options, is always latched and cannot be reset by MR.



Note: The trip alarms and analog output (AO) are independent from the fault alarms and will be unaffected by the fault alarms (however they may be affected by the specific failure in the unit).

Configuration diagnostics

On power up the stored configuration is validated. If it is invalid then the fault alarm will be set. To clear the alarm, use the menu system, to reset to the factory configuration (FCTRY CONFIG selection in the options menu), then configure as appropriate for the application.

Before saving a new configuration to the unit, it will be checked for validity. If it is invalid, the fault alarm will be set. Once the configuration is corrected, the fault alarm will be cleared.

Input diagnostics

The STA has extensive hardware diagnostics of the input to detect broken wire and saturation. It also detects out of range and linearization errors.

Broken wire is automatically set on the STA and enables the system to distinguish between a low trip condition (which sets the trip alarm) and a failed transmitter or open input (which sets the fault alarm).

All input faults will be alarmed on the fault relay. Depending on the configuration, they may or may not be latched (default is latched). A latched input fault alarm can be cleared by first clearing the input failure and then using the configuration menus or MR (if configured) to reset faults. If the input error is not cleared when resetting the fault alarm, the error condition will immediately be re-applied and will not cause the relay to glitch.



Note: For STA units with firmware versions 1.5 and earlier, the fault alarm has no configuration options, is always latched and cannot be reset by MR.



Note: The trip alarms are independent from the fault alarm and will be unaffected by the fault alarm. Therefore if the trip alarm has already been activated it will remain so but will NOT be activated by a broken wire or input saturation error. The analog output (AO) will respond to an input error and will be set to its programmed fail response. For broken wire detection, this only applies if the input is immediately broken. If there is degradation of sensor wires, false readings could occur before the wire breaks and the trip alarm could be activated before the fault alarm. (Slow degradation is characterized by events that occur over a span of a second or so).

STA Diagnostic Messages

Every STA is subjected to a complete suite of operational checks and tests prior to its shipment. Occasionally, however, units can sustain damage in transit from the factory to the user.

The STA is also equipped with a full set of internal diagnostics that check operation and configuration upon power-up. If there are problems with the unit, or with conflicting operating parameter settings, the LCD will display an error message upon unit start-up, and the fault alarm will remain set. Identical diagnostics are performed in the background during run time. If a fault is detected, the fault alarm will immediately be set, and an error message will be displayed.

Table 6.1 provides a full list of diagnostic messages and corrective actions.

Table 6.1. STA Diagnostic messages and corrective actions messages

Error Message	What it Means	What to Do
SYS INIT	The system is completing initialization	Wait. Operation should commence in a few seconds.
ERROR CKSUM	The configuration stored in non-volatile memory is invalid	Using the menu system, trigger the unit to use the FCTRY CONFIG selection in the options menu causing it to reset to factory configuration. Next configure as appropriate for the application.
ERROR CONFIG	User has reconfigured the unit with an illegal configuration	Usually caused by changing the input range, or scaled range such that the trip points and/ or deadband settings have become illegal. Reconfigure with legal values.
WIREn BROKE	A specific wire was detected as broken	Repair the broken wire(s), and use the menu system to RESET FAULTS or MR Terminal (if configured) or cycle power.
WIRES BROKE	Undetermined wire broken	
ERROR INSAT	Input saturation condition (input reached 110% of calibrated range)	Check the input signal to ensure that it is within the sensor limits and use the menu system to RESET FAULTS or MR Terminal (if configured) or cycle power.
ERROR OOR	Input has gone outside the legal range (as defined by the input LRV and URV by more than 1%)	Check the input and/or the input Upper and Lower Range settings and use the menu system to RESET FAULTS or MR Terminal (if configured) or cycle power.
ERROR CALIB	Calibration data is bad	These errors are generated by internal diagnostics (see STA Diagnostics and Fault Alarms p7). Spurious errors that could be caused by external factors like transients or surges, may result in a diagnostic failure and trigger the fault alarm. Cycle power to the unit to clear the latched fault alarm. If the error persists, then please record the error message and contact Moore Industries Customer Support for further assistance.
ERROR FCTRY/ INFO	Factory information is bad	
ERROR ADC __ *	General ADC failure	
ERROR RLAYF	Fault alarm failure	
ERROR RLAY1	Trip alarm 1 hardware failure	
ERROR RLAY2	Trip alarm 2 hardware failure	
ERROR SW ___ *	General software failure detected by diagnostics	
ERROR HW ___ *	General hardware failure detected by diagnostics	

* Error messages ERROR ADC, ERROR SW, and ERROR HW will also include a 2 or 3 digit suffix. Moore Industries Customer Service Technicians will use these codes to help determine the origin of the error.



Note: The Manual Reset (MR) will only reset Input Faults if configured in the Alarms Menu.

Maintenance

Moore Industries recommends that the calibration of this instrument should be checked every year and re-calibrated only when necessary. In addition, we suggest a quick check for terminal tightness and general unit condition. Always adhere to any site requirements for programmed maintenance.

Section 7 - STA in Safety Instrumented Systems

The STA is designed for use as an element of a safety instrumented system as defined by IEC61508-4 para 3.4.1.

This user manual contains all of the information needed to configure, install, operate and maintain this product. For safety applications the STA must only be used in accordance with this information and the restrictions and limitations as detailed below.

Functional Safety Description

The STA has been certified, by exida® to IEC61508:2010 for systematic integrity up to SIL3 and for random integrity up to SIL2. This means that an STA is approved for single use in Safety Instrumented Systems (SIS) up to SIL2 and in a redundant architecture (1oo2, 2oo3, etc.) up to SIL 3. It is classified as a Type B device according to IEC 61508. Therefore, table 2 in IEC61508-1 and table 3 in IEC61508-2 provide the Safety Failure Fraction (SFF) and PFDAVG requirements for a given SIL rating.

The STA is a programmable alarm which accepts current and voltage as input for High-Level (HLPRG) units. Two programmable relays, used as process trip alarms, and one SPDT relay, used as the fault relay are provided as outputs. An optional Analog Output (AO) is also provided. Operating power is supplied external to the unit. For safety systems, the STA performs as an alarm trip and/or transmitter which processes the input signal(s) and sets the output trips and optional 4-20mA output current according to its configuration. The safety output is either configured as an output trip or as an analog output. In both cases the fault relay must be used to detect faults.



Note: For units with firmware V1.2 or earlier, the STA is certified to 61508:2000 by TUV Rhineland. For units with firmware V1.3, the STA is certified to 61508 by both TUV Rhineland and exida®. For units with firmware V1.5 and later, the STA is certified to 61508:2010 by exida®.

Failure Rate Data

The STA FMEDA report (Moore Industries' Document No: 700-702-32) provides the failure data (including PFD and SFF) required for calculations to use the STA as part of a Safety Instrumented System.

Product life

The product life of the STA is 20 years (based on worst case component life data).

However, IEC 61508-2, section 7.4 states that a useful lifetime based on experience has more weight than the calculated figures; Note 3 in the section comments that the useful lifetime of a transmitter is most often within 8 to 12 years.

Installation

No special installation is required in addition to the standard installation practices in this user manual. Refer to the specifications table of this user manual for ambient conditions and required power input.

Prior to use in a safety function, the user must validate the operation of the device offline (see bench check in Section 2).

Configuration

The unit can be configured using the front panel buttons or PC Configuration Software as described in this manual.



Note: While the system is in configuration mode the system is in an offline mode and is not performing the safety function

Do not attempt to connect the STA communications cable to the STA while the output relays are connected to a load.

After making any configuration changes, the user must validate the operation of the STA offline to ensure that the changes work safely, prior to putting it back into operation.

The following considerations and restrictions will apply when using the STA in a safety application:

Trip Relay used as safety output: One or both trip alarms must be connected to the actuator/equipment under control (EUC). The separate dedicated fault relay must either be connected in series with the trip alarm OR connected to a separate indicator to only alarm the fault while maintaining the process in normal operation. Refer to Figures 8.1 and 8.2 in Section 8 for typical STA configurations.

Analog Output (AO) used as safety output: The STA may optionally be provided with an analog output (AO) which can be used for connecting to displays, control systems, etc.

For STA units with V1.2 firmware or less, the AO is NOT certified for safety use and must not be used as any part of a safety loop. The analog circuit is isolated from the STA safety circuits and consequently its failure will not compromise the certified safety function of the STA.

For STA units with V1.3 firmware or later, the AO is certified for safety use and can be used in the safety path. Figures 8.4 and 8.5 in Section 8 for typical configurations.

The AO must be configured as follows: The AO is a current output set at 4 to 20mA. The AO is set to fail low (fail high is a non fail-safe condition when power is lost). The logic solver is either configured to detect a 'fail low' condition for SIL1 applications (anything less than 4.0mA is detected as a fault) or a 'fail windowed' condition for SIL2 applications (anything outside the 4-20mA range is detected as a fault). The fault alarm relay is used by the logic solver to detect failures.



Note: When configuring Out of Range for STA units with firmware V1.5 or later, the Out of Range value must be configured for 2% or less (default setting is 1%).

High Availability Configuration

(Figures 8.1 & 8.2)

Separating the process and fault loads increases availability but its use must be authorized only after a careful hazard and operability study involving suitably qualified persons.



Warning: With this configuration, an internal STA fault would not trip the EUC.

Sensor Types

The STA is designed for use with a wide variety of inputs. It is the end user's responsibility to ensure that the chosen sensor is capable of achieving the required loop SIL.

Broken Wire Detection

The STA is provided with the facility to detect both open circuit and short circuit input. This broken wire detection must always be enabled. This is essential to ensure that dangerous failure of the sensor or signal input is detected by the STA and consequently alarmed.



Warning: For HIGH LEVEL INPUT, the Lower Range Value (LRV) must be set higher than zero. Broken Wire Detection will be disabled if LRV is set to zero and will invalidate the safety function.

Sensor Trimming Enable/Disable

Sensor trimming should be used with extreme care as this facility is allowed to trim the sensor accuracy by as much as 2% of the trimming point value. It is the user's responsibility to ensure that the safety application can tolerate this.

Latching Mode Enable/Disable

The STA is provided with the capability to latch on a trip, i.e. once the output process alarm relays have de-energized they will remain de-energized until either the manual reset contact is closed or the unit is power cycled. The use of this facility will be determined by the application. It is recommended that if the output state is latched externally to the STA, the STA latching option is disabled. Please note that the fault alarm can be configured to Latch or not Latch on Input Faults. The Input Fault is latched by default.



Note: For STA units with firmware versions 1.5 and earlier, the fault alarm has no configuration options, is always latched and cannot be reset by MR.

Remote Manual Reset – Procedural Issues

The STA has a facility for the connection of a remote switch to release the latch on the outputs, if configured, this includes input faults (configurable in units with firmware V1.5 or later).

This function is meaningful only when automatic latching of outputs and/or input faults is selected in the configuration. If the manual reset is made part of the safety procedure, it must only be used under strict supervisory and procedural control. The use of a key operated momentary contact is suggested.

Process Safety Time

Process safety time is the minimum time from the initiation of a hazardous event to the point where the hazardous event is unavoidable. Any safety function designed to either prevent the event or at least mitigate its effect must be capable of performing its specified safety function in a time period very much less than the process safety time.

The STA has a characteristic response time (end to end) of 256mSec. The total diagnostic test time of the unit is 15 minutes.

Operation and Maintenance

Proof Test Procedure

It is normal practice with SIS that the components undergo periodic proof tests to expose dangerous faults that are not detected by internal diagnostic tests. Thus, this section specifies how the dangerous undetected faults determined during the FMEDA can be detected during proof testing.

Calculation of the required proof test interval can be made using data in the FMEDA report (Moore Industries' Document No: 700-702-32).

The proof tests described in Table 7.1 and Table 7.2 are designed to cover all possible dangerous undetected faults that can be detected without opening the unit (proof test coverage is 97%). Periodically testing the STA, using the proof test steps outlined below, the accumulated PFD_{AVG} value can be reduced to a smaller but non-zero value. To completely test for all possible dangerous undetected faults, the unit must be sent back to the factory for a comprehensive proof test inspection.

Repair and Replacement

The STA is not intended to be repaired on site and has no components needing maintenance or regular replacement. On device failure, the STA should be returned to Moore Industries Worldwide Headquarters in North Hills, CA 91343 U.S.A for repair and refurbishment (refer to Returns Procedures at the end of this manual).

The STA is a certified Safety component. Repair or replacement of any component without authorization from Moore Industries International, Inc. will invalidate any remaining warranty and the IEC61508 certification.

Recording and Reporting of STA Performance

It is the end user's responsibility to maintain records of all safety component failures, especially those that might be classified as potentially dangerous.

This feedback data not only helps the supplier identify and rectify reliability issues but also to provide quantitative data to increase confidence in the FMEDA analysis of dangerous failure rates. Please ensure that any components returned to Moore Industries International, Inc. are returned with a clear report identifying the fault experienced.

Proof Tests

Table 7.1. STA HLPRG proof test steps

Step	Action
1	Bypass the safety PLC or take other appropriate action to avoid a false trip
2	Disconnect all wires from the STA. Using an ohmmeter, measure the resistance between the case and all exposed pins on the front. Verify that the measured resistance is greater than 1 MΩ with the exception of the GND pin which should have a 0Ω resistance. This test for shorts between the power, input and output to case and verifies that ground is connected to case.
3	Resupply power. Connect a loop device powered by the TX output. Configure all alarm outputs such that: i. Each alarm is set to the midpoint of the configured range ii. Alarm 1 is set to trip when the input is below the midpoint, Alarm 2 is set to trip when the input is above the midpoint
4	Cause the loop device to go to its maximum output value. Verify that the device is not power starved, eg displaying symptoms of power cycling, browning out, etc. Verify that the STA is measuring the input from the loop device correctly by viewing the display or using the STA transfer utility in monitoring mode <i>This verifies the proper operation of the TX supply circuit and that the supplied current is not below the maximum requirements of the loop device</i>
5	Remove loop device from previous step and install one (1) 2k ohm (1/2W) resistor to each Common (CM1, CM2 and CM3) terminal. Connect remaining end of resistors to 24Vdc +/-5%. Connect each normally open (NO1, NO2 and NO3) terminal to 24Vdc Return.
6	Apply a calibrated input near the high limit of the selected input configuration. Verify that the input as reported by viewing the display matches what is expected. Also using a voltmeter, measure the voltage across each of the normally open (NO1, NO2 and NO3) and common (CM1, CM2 and CM3) terminals. Verify that the measured voltages across NO1 & NO3 is less than 0.1V and NO2 is between 22.8 and 25.2V. <i>This tests for failures in the input connections to the A/D converter near the high limit operation. This also covers the CPU, A/D clocks and each relay and for issues in the relay to output connections.</i>
7	Apply a calibrated input near the low limit of the selected input configuration. Verify that the input as reported by viewing the display matches what is expected. Also using a voltmeter, measure the voltage across each of the normally open (NO1, NO2 and NO3) and common (CM1, CM2 and CM3) terminals. Verify that the measured voltages across NO1 is between 22.8 and 25.2V and NO2 & NO3 are less than 0.1V.
8	Disconnect wire connected input COM terminal. Verify that the fault is reported on display and Fault LED turns red. Also using voltmeter, measure the voltage across NO3 and CM3. Verify that the measured voltage across NO3 and CM3 is between 22.8 and 25.2V.
9	Remove connection to each normally open (NO1, NO2 and NO3) terminal to 24Vdc Return and connect each normally closed (NC1, NC2 and NC3) terminal to 24Vdc Return.
10	Apply a calibrated input near the high limit of the selected input configuration. Verify that the input as reported by viewing the display matches what is expected. Also using a voltmeter, measure the voltage across each of the normally closed (NC1, NC2 and NC3) and common (CM1, CM2 and CM3) terminals. Verify that the measured voltages across NC1 & NC3 are between 22.8 and 25.2V and NC2 is less than 0.1V.
11	Apply a calibrated input near the low limit of the selected input configuration. Verify that the input as reported by viewing the display matches what is expected. Also using a voltmeter, measure the voltage across each of the normally closed (NC1, NC2 and NC3) and common (CM1, CM2 and CM3) terminals. Verify that the measured voltages across NC1 is less than 0.1V and NC2 & NC3 are between 22.8 and 25.2V.
12	Disconnect wire connected input COM terminal. Verify that the fault is reported on display and Fault LED turns red. Also using voltmeter, measure the voltage across NC3 and CM3. Verify that the measured voltage across NC3 and CM3 is less than 0.1V <i>This test completes the full test for failures in the input connections to the A/D converter near the low limit operation and fault conditions. This also covers the CPU, A/D clocks and each relay and for issues in the relay to output connections.</i>
13	Restore the STA to its original configuration
14	Restore the loop to full operation
15	Remove the bypass from the safety logic solver or otherwise restore normal operation

The tests outlined below provide coverage only for the AO portion of the STA. It is necessary to perform the proof tests in both Table 7.1 and Table 7.2 if the Analog output is part of the safety path.

Table 7.2. STA HLPRG Analog Output proof test steps

Step	Action
1	Bypass the safety PLC or take other appropriate action to avoid a false trip
2	Configure the STA for 2-10V input with broken wire set at 2V
3	Provide an input of 4V. Verify that the analog output is within 2% of 8.0mA
	<i>This, in addition to the next step verifies that there are no failures that cause the AO to have more than 2% error as well as lose linearity</i>
4	Provide an input of 8V. Verify that the analog output is within 2% of 16.0mA
	<i>This, in addition to the previous step verifies that there are no failures that cause the AO to have more than 2% error as well as lose linearity</i>
5	Restore the STA to its original configuration
6	Restore the loop to full operation
7	Remove the bypass from the safety logic solver or otherwise restore normal operation

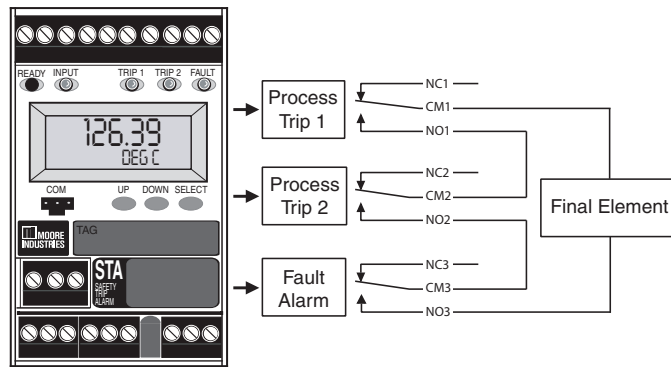
Section 8 - Applications

The following are examples of typical STA configurations.

High Integrity Alarm Trip

The configuration shown in Figure 8.1. offers the highest trip integrity. Since the trip and fault relays are wired in series, any trip alarm or STA fault will trip the final element or logic solver. However this configuration is vulnerable to spurious trips as STA safe failures will also trip the final element.

Figure 8.1. High Integrity Alarm Trip example

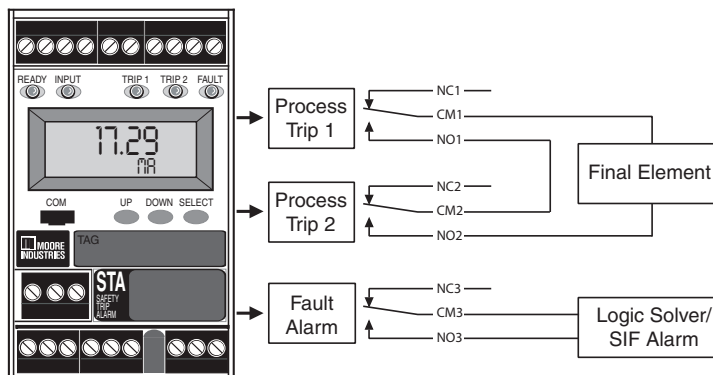


High Availability Architecture

The configuration shown in Figure 8.2. offers higher system availability. The Fault alarm is wired separately to inform the safety system that there is a fault alarm and that this component's ability to carry out its portion of Safety Instrumented Function cannot be performed. This configuration can be used in applications where it is safe to keep the process running for a short time while a defective instrument is repaired, however this configuration will NOT trip if an STA fault is diagnosed.

This type of configuration must be used with care in a safety system. The end user must determine how long the process is allowed to continue after a STA fault is detected and ensure that the unit can be repaired or replaced within this time.

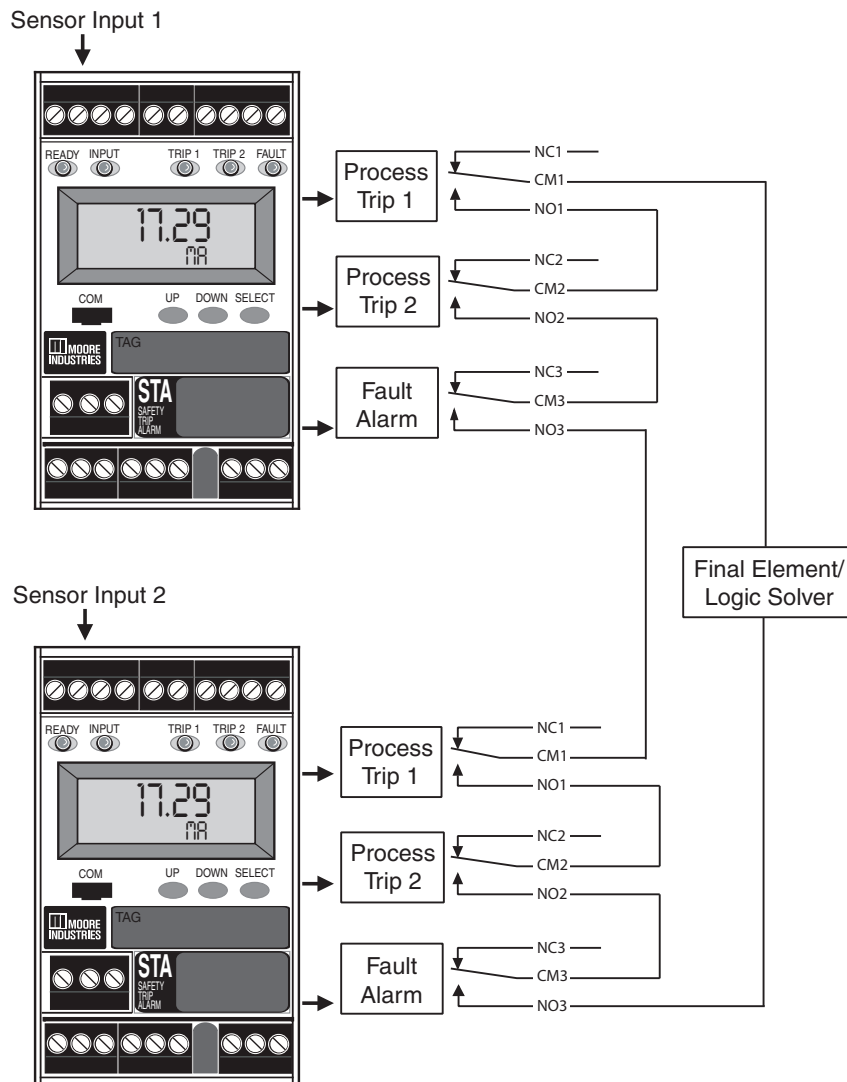
Figure 8.2. High Availability Alarm Trip example



1oo2 Redundant Architecture

In this architecture, every component appears twice, and may be applicable for use in SIS systems up to SIL 3 (Figure 8.3). Advantages are improved reliability of trip action and reduced vulnerability to a single failure compared to a 1oo1 architecture. The logic in this configuration is an 'OR' statement for the safety function; if either sensor input reaches a trip condition or a fault relay is activated, the loop or function will reach a tripped state.

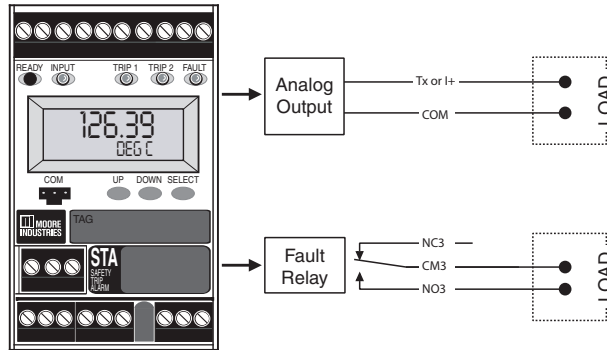
Figure 8.3. The STA in a 1oo2 Redundant/Voting Architecture is Applicable for Use in SIS Systems Up to SIL 3.



Analog Output in the Safety Path

When the Analog Output is used in the safety path, the fault alarm must also be monitored to detect STA failures. In Figure 8.4 below, the fault alarm is wired separately in a high availability architecture. The fault alarm can also be wired in series with the Analog Output to provide a high integrity architecture..

Figure 8.4. The STA with Analog Output (AO) in the Safety Path



Note: When power is lost the AO will fail low. For this reason in a safety application, the logic solver must be either configured to detect a 'fail low' condition (anything less than 4.0mA is detected as a fault) or 'fail windowed' condition (anything outside the 4-20mA range is detected as a fault).

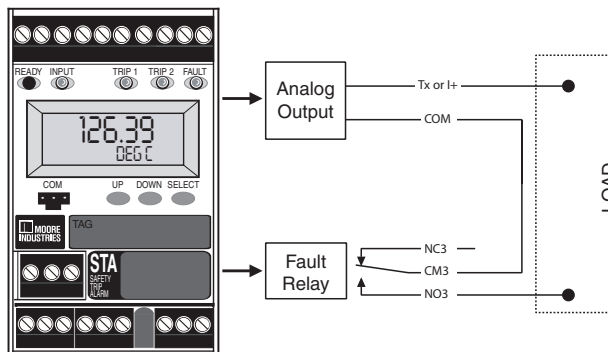


Note: For STA units with V1.3 firmware or greater, the AO can be used in the safety path.

High Integrity Analog Output

The configuration shown in Figure 8.5. offers the highest AO integrity. Any input or STA fault will drive the AO signal out of range. However this configuration is vulnerable to spurious trips as STA safe failures will also drive the AO signal out of range.

Figure 8.5. High Integrity Analog Output example



Section 9 - Specifications

Performance **Input Range:** Current Input 0-50mA (4mA minimum span); Voltage Input 0-11V (1V minimum)

Input Accuracy and Alarm Trip Repeatability: Current inputs, 2microamps (0.01% of 20mA span); Voltage inputs, 1mV (0.01% of maximum span)

Overall Accuracy:
The overall accuracy of the unit is the combined input and output accuracies. It includes the combined effects of linearity, hysteresis, repeatability and adjustment resolution. It does not include ambient temperature effect.

Stability: Refer to Table 9.1

Dead Band: 11V or 50mA, maximum in Linear Mode; equivalent of maximum input range in user-set engineering units in Scaling/Custom Mode

Input to Output Trip Response Time:
256msec maximum from step change on input to alarm state change when alarm is set to trip at mid-point of step

Alarm Trip Delay: Programmable from 0-120 seconds (0-60 seconds for firmware versions 1.1.2 and earlier)*

Isolation: 500Vrms between case, input, output, and power

Dielectric Strength: 1966Vdc for 2 seconds, between case, input, output, and power

Power Supply:
U range 21.6-375Vdc or 90-260Vac;
*24DC range, 18-30Vdc;
*UAC range, 90-260Vac;

Power Consumption:
5W max for Universal; 3.5W maximum for DC supply; 4W max for UAC supply

Power Supply Effect: ±0.002% of span per 1% line voltage change

Input Over-Range Protection: Current, ±100mA, maximum; Voltage, ±30Vdc, maximum

Input Impedance: Current, 20 ohms; Voltage, 1Mohm

TX Power Supply: 24Vdc, ±10% @ 24mA (regulated)

Output Relays
Dual Process Relays and One Fault Relay (Relays are single-pole/double-throw SPDT, 1 form C, rated 3A @250Vac or 3A @30Vdc, 50/60Hz, non-inductive)

Performance of Analog Output (-AO option) **Analog Output Option**

Output Accuracy: Current, ±0.01% of maximum span (±2 microamps); Voltage, ±0.01% of max. span (±1mV)

Input to Analog Output Response Time:
256msec for the output to change 10% to 90% of its scale for an input step change of 0 to 100%

Analog Output Step Response Time:
100msec maximum

Analog Output Ripple (up to 120Hz): 50mV peak-to-peak maximum on voltage output; 10mV peak-to-peak measured across a 250 ohm load resistor for current output

Analog Output Range: Current Output 0-21.6mA, Minimum Span 4mA; Voltage Output -0.2-10.5V; Minimum Span 1V

Performance of Analog Output (-AO option) (continued) **Analog Output Current Limiting:**

Current outputs:

Output	Failure Limits
0-20mA	0, 23.6mA
4-20mA	3.6, 23.6mA
X-20mA (0<X<4)	(90% of X), 23.6mA

Voltage output:
Failure Limit: -0.50 -11.0V

Load Capability: Source mode (internal power supply), 0-1 kohms for current output; 2 kohms for voltage output; Sink Mode (External power Supply), 42Vdc Max

Load Effect (current outputs): ±0.01% of span from 0 to maximum load resistance on current output

Ambient Conditions **Operating Range:**
-40°C to +85°C
(-40°F to +185°F)

Relay Range:
-40°C to +85°C
(-40°F to +185°F)

Storage Range:
-40°C to +85°C
(-40°F to +185°F)

Ambient Temperature Effect: Current, 2 microamps/°C; Voltage, 1mV/°C; Output, ±0.009% of max. span/°C

Relative Humidity: 5-95%, non-condensing

RF/EMI Protection:
20V/m@80-1000MHz, 1kHz AM, when tested to IEC61326

Noise Rejection: Common Mode, 100dB @50/60Hz
Normal Mode, Current Input, 70dB typical @ 50mA_{p-p}@ 50/60Hz; Voltage Input, 70dB typical @1V_{p-p}@ 50/60Hz

Adjustments Front panel push-buttons for parameter configurations; Internal jumper and menu password protect parameter settings

Indicators **LCD:** 2x5 14-segment characters, backlit, alphanumeric readout accurate to the nearest digit.
Range: -99999 to 99999; Decimal point can be user-set
LED Type:
INPUT LED: Dual color LED indicates input failure
READY LED: Green LED indicates unit is operating properly
ALARM 1 and 2 LED: Dual color LED per relay indicates alarm status
FAULT LED: Green LED indicates unit is operating properly; Red LED indicates unit has fault or is latched.

Display Accuracy:
±1 digit; when scaling the display (or in custom mode), high input-to-display span ratios decrease display accuracy

Weight 513 g to 564 g
(18.1 oz to 19.9 oz)

* Power Supply options no longer available for purchase

Table 9.1. Long-Term Stability

Stability (% of maximum span)	Input to Analog Output (Years)			Input to Relay (Years)		
	1yr	3yrs	5yrs	1yr	3yrs	5yrs
Current Inputs	0.081	0.14	0.18	0.047	0.081	0.105
Voltage Inputs	0.093	0.16	0.21	0.066	0.114	0.147

Section 10- Ordering Information

The STA HLPRG ordering information is detailed below.

Unit	Input	Output	Power	Options	Housing
STA Programmable SIL 2 Compliant Programmable Safety Trip Alarm	HLPRG Programs to accept: Current: Any range between 0-50mA including: 0-20mA, 4-20mA, 10-50mA Voltage: Any range between 0-10Vdc including: 0-5Vdc, 1-5Vdc, 0-10Vdc	3PRG Dual Process Relays and One Fault Relay (Relays are single-pole/double- throw; SPDT, 1 form C, rated 3A@250Vac or 3A@30Vdc, 50/60Hz, non- inductive) Process Relays #1 and #2 individually configure for: High Alarm Low Alarm Normally Open Normally Closed (Both relays are fixed as Failsafe) Fault Relay #3 is fixed as Failsafe	U Accepts any power input range between 21.6-375Vdc or 90-260Vac.	-AO Analog output (isolated and linearized) scalable for any range between 0-21.6mA into 1 kohms or -0.2-10.5V into 2 kohms (Current output is user-selected for internal, source or external power, sink)	DIN DIN-style housing mounts on 35mm (EN50022) Top Hat DIN-rails FLB Externally- mounted flange provides a secure mount for high vibration applications

When ordering, specify: Unit / Input / Output / Power / Options [Housing]

Model number example: STA / HLPRG / 3PRG / U / -AO [DIN]

Accessories

Each STA order comes with one copy of our Intelligent PC Configuration Software. Use the chart below to order additional parts.

Part Number 700-702-32	FMEDA Report consistent with IEC 61508-2:2010 providing the information necessary to design a Safety Instrumented System (One copy provided free with each order Upon Request)
Part Number 750-75E05-01	Intelligent PC Configuration Software One CD copy provided free with each order (Standard) or, Line Item or Unit (Upon Request)
Part Number 803-053-26	Serial Configuration Cable for use in connecting the STA to a PC via 9-Pin Serial port
Part Number 804-030-26	Fuse Protected, Non-isolated USB Communication Cable for use in connecting the STA to a PC via USB Port

Warranty Disclaimer

Moore Industries ("The Company") makes no express, implied or statutory warranties (including any warranty of merchantability or of fitness for a particular purpose) with respect to any goods or services sold by the company. The company disclaims all warranties arising from any course of dealing or trade usage, and any buyer of goods or services from the company acknowledges that there are no warranties implied by custom or usage in the trade of the buyer and of the company, and that any prior dealings of the buyer with the company do not imply that the company warrants the goods or services in any way.

Any buyer of goods or services from the company agrees with the company that the sole and exclusive remedies for breach of any warranty concerning the goods or services shall be for the company, at its option, to repair or replace the goods or services or refund the purchase price. The company shall in no event be liable for any consequential or incidental damages even if the company fails in any attempt to remedy defects in the goods or services, but in such case the buyer shall be entitled to no more than a refund of all monies paid to the company by the buyer for purchase of the goods or services.

Any cause of action for breach of any warranty by the company shall be barred unless the company receives from the buyer a written notice of the alleged defect or breach within ten days from the earliest date on which the buyer could reasonably have discovered the alleged defect or breach, and no action for the breach of any warranty shall be commenced by the buyer any later than twelve months from the earliest date on which the buyer could reasonably have discovered the alleged defect or breach.

Return Policy

For a period of thirty-six (36) months from the date of shipment, and under normal conditions of use and service, Moore Industries ("The Company") will at its option replace, repair or refund the purchase price for any of its manufactured products found, upon return to the Company (transportation charges prepaid and otherwise in accordance with the return procedures established by The Company), to be defective in material or workmanship. This policy extends to the original Buyer only and not to Buyer's customers or the users of Buyer's products, unless Buyer is an engineering contractor in which case the policy shall extend to Buyer's immediate customer only. This policy shall not apply if the product has been subject to alteration, misuse, accident, neglect or improper application, installation, or operation. THE COMPANY SHALL IN NO EVENT BE LIABLE FOR ANY INCIDENTAL OR CONSEQUENTIAL DAMAGES.

To return equipment to Moore Industries for repair, follow these four steps:

1. Call Moore Industries and request a Returned Material Authorization (RMA) number.

Warranty Repair –

If you are unsure if your unit is still under warranty, we can use the unit's serial number to verify the warranty status for you over the phone. Be sure to include the RMA number on all documentation.

Non-Warranty Repair –

If your unit is out of warranty, be prepared to give us a Purchase Order number when you call. In most cases, we will be able to quote you the repair costs at that time. The repair price you are quoted will be a "Not To Exceed" price, which means that the actual repair costs may be less than the quote. Be sure to include the RMA number on all documentation.

2. Provide us with the following documentation:
 - a) A note listing the symptoms that indicate the unit needs repair
 - b) Complete shipping information for return of the equipment after repair
 - c) The name and phone number of the person to contact if questions arise at the factory
3. Use sufficient packing material and carefully pack the equipment in a sturdy shipping container.
4. Ship the equipment to the Moore Industries location nearest you.

The returned equipment will be inspected and tested at the factory. A Moore Industries representative will contact the person designated on your documentation if more information is needed. The repaired equipment, or its replacement, will be returned to you in accordance with the shipping instructions furnished in your documentation.



Demand Moore Reliability • www.miinet.com

United States • info@miinet.com
Tel: (818) 894-7111 • FAX: (818) 891-2816
Australia • sales@mooreind.com.au
Tel: (02) 8536-7200 • FAX: (02) 9525-7296

Belgium • info@mooreind.be
Tel: 03/448.10.18 • FAX: 03/440.17.97
The Netherlands • sales@mooreind.nl
Tel: (0)344-617971 • FAX: (0)344-615920

China • sales@mooreind.sh.cn
Tel: 86-21-62491499 • FAX: 86-21-62490635
United Kingdom • sales@mooreind.com
Tel: 01293 514488 • FAX: 01293 536852