

## PERSEUS HIGH

## PRESSURE

# PF60 PERSEUS ATEX & IECEx Exd, Exia & INDUSTRIAL PRESSURE SWITCH

This range of switches features a robust high quality housing with 1 or 2 sealed SPDT microswitches and has been designed for use in environments where explosive gases can be present (e.g. gas fields, oil rigs & chemical plants etc). Microswitches can be set for single, dual simultaneous, or dual independently adjustable operation. Environmentally sealed or hermetically sealed microswitch options are available.

One of the benefits of the Perseus range is the separation of the flameproof and adjustment chambers allowing adjustment of the set point with power on and the switch in operation. The housing is available with one or two electrical entries.



## HIGH PRESSURE

## FEATURES

- ✓ 316 Stainless steel or black anodised aluminium switchcase to IP66 & IP67 standards.
- ✓ Wetted parts NACE MR-01-75 compliant
- ✓ SIL 2 - IEC61508 proven reliability.
- ✓ Single or dual microswitches option.
- ✓ Settings from 4 bar to 800 bar
- ✓ ATEX/IECEx Flameproof version II 2 G Ex db IIC T6...T5 Gb (Tamb -50°C to +75°C...+90°C) (with or without resistors)
- ✓ ATEX/IECEx Intrinsically safe version II 1 G Ex ia IIC T6...T2 Ga (Tamb - 50°C to +78°C...+93°C) (without resistors)
- ✓ ATEX/IECEx Intrinsically safe version II 1 G Ex ia IIC T5 ...T2 Ga (Tamb - 50 to +72°C...+122°C) (with resistors)
- ✓ ATEX/IECEx Intrinsically safe version II 1 D Ex ia IIIC T135°C Da (Tamb -50°C to +70°C) (with or without resistors)

# HIGH PRESSURE RANGES

## Piston actuated with sealing ring

Dual microswitches will increase the stated deadband.

ADJUSTMENT RANGE bar	ADJUSTMENT RANGE psi	MAX. WORKING PRESSURE bar	DEADBAND bar	PISTON CODE	SPRING CODE
4 - 17.5	60 - 230	700	0.5 - 1.5	S6	B
10 - 36	140 - 540	700	1 - 3	S6	W
28 - 108	400 - 1600	700	2 - 8	S3	W
50 - 200	725 - 2825	700	3 - 15	S2	W
115 - 455	1600 - 6600	700	8 - 35	S1	W
200 - 800	2900 - 11600	1000*	15 - 60	S7	W

\*1/4" Process connection. Only 700 Bar if 1/2" conn. selected

Wetted parts : 316 stainless steel with either Viton (std), Nitrile, PTFE or EPDM dependant on selection.

PART NUMBER BREAKDOWN		ELECTRICAL CONNECTIONS _ = M20 LEAVE BLANK C = 1/2" NPT ADAPTOR F = M25 ADAPTOR		
<b>SWITCHCASE</b> PF6 = STANDARD PR6 = RESISTOR OPTION	<b>MICROSWITCH OPTIONS</b> 1 = 1 X SPDT 2 = 2 X SPDT LINKED 3 = 1 X SPDT ADJUSTABLE DEADBAND 4 = 2 X SPDT INDEPENDENTLY ADJUSTABLE 5 = 1 X HERMETIC SEALED 6 = 2 X HERMETIC SEALED	<b>SPRING CODE</b> PLEASE REFER TO RANGE TABLE	<b>PISTON CODE</b> PLEASE REFER TO RANGE TABLE	<b>BRACKET</b> X = STD - NO BRACKET H = 2" PIPE BRACK (ALUM) K = 2" PIPE BRACK (ST.ST) M = GUARDIAN REPLACEMENT (ST.ST) N = GUARDIAN REPLACEMENT (ALUM) R = TITAN REPLACE (ALUM) S = TITAN REPLACE (ST.ST)

P F 6 1 S B / B W 3 2 / S 7 X B \_

<b>SWITCHCASE MATERIAL</b> A = BLACK ANODISED ALUMINIUM S = STAINLESS STEEL	<b>SEAL MATERIAL</b> A = NITRILE B = VITON D = PTFE* E = EPDM** <small>* FOR SETTINGS ABOVE 10 BAR. MAX 100 BAR ** NOT AVAILABLE WITH S7 PISTON * &amp; ** FEMALE PROCESS CONNECTION ONLY</small>	<b>PROCESS CONNECTION</b> 31 = 1/4" BSP.P FEMALE 32 = 1/4" NPT FEMALE 33 = 1/2" BSP.P FEMALE 34 = 1/2" NPT FEMALE 41 = 1/2" BSP.P MALE 42 = 1/2" NPT MALE <small>*1000 BAR MAX PRESSURE ONLY AVAILABLE WITH 1/4" PROCESS CONNECTION.</small>	<b>ELECTRICAL CONNECTION ENTRY</b> B = RIGHT HAND SIDE L* = DUAL ENTRY T* = DUAL ENTRY TOP PLUGGED R* = DUAL ENTRY SIDE PLUGGED <small>*STAINLESS STEEL CASE ONLY</small>
<b>CERTIFICATION</b> O = ATEX/IECEX Exia INTRINSIC. SAFE B = ATEX/IECEX Exd FLAMEPROOF A = INDUSTRIAL / MARINE			

DIMENSIONS IN MILLIMETERS UNLESS OTHERWISE STATED

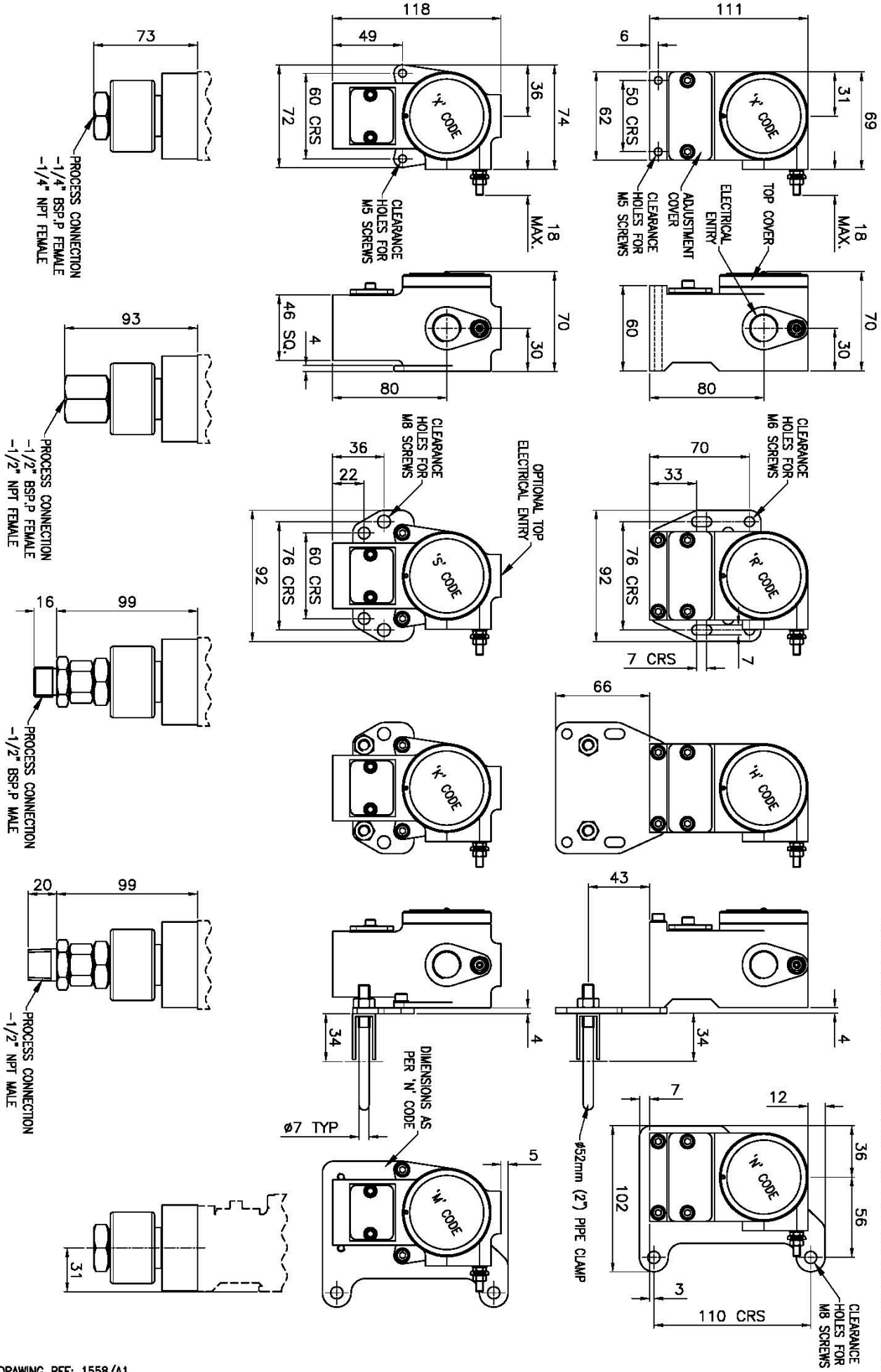

# PERSEUS ATEX & IECEx Exd, Exia &

## INDUSTRIAL SWITCHES

### INTRODUCTION

The Perseus **pressure, vacuum, differential pressure, temperature, and level** switches are designed for use in environments where explosive gases and dust can be present (e.g. Gas fields, Oil rigs and Chemical plants etc.) and have been ATEX and IECEx certified as detailed overleaf (SIL2 - IEC61508 proven reliability).

These switches are manufactured from a high quality casting which offers robust construction and protection to IP67 for use within heavily polluted industrial environments. A special feature of the instruments is the separation of the flameproof and adjustment compartments allowing for safe on-site adjustment of the set point with power on and the switch in operation.

Perseus Exd switches must be installed in accordance with BS EN 60079-14

### CALIBRATION

The design features a simple form of adjustment against a calibrated scale. This enables a user to order switches set at a predetermined point or stock a mid range setting and adjust switches to suit the particular application. The set point can be safely adjusted with the switch electrically live. Adjustment is made by removing the access cover and rotating the set point adjuster using a suitable tommy bar stowed to the right of the scale plate. The setting is read from the centre of the set point adjuster against the calibrated scale. Rotation to the left will increase the set point and to the right decrease it.

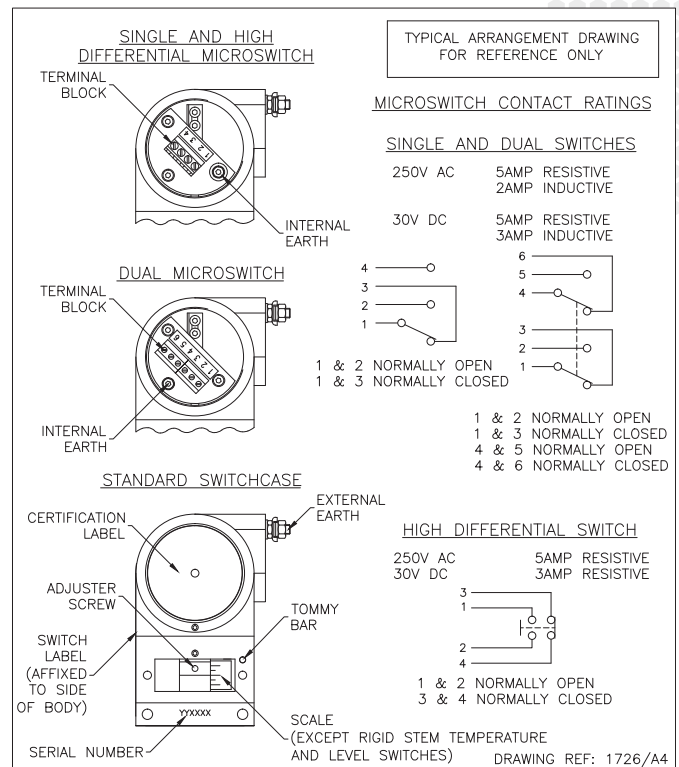

Perseus Stainless steel switchcase with dual electrical connection option

# TECHNICAL SPECIFICATION

**Switchcase & covers:** 316 Stainless steel or black anodised aluminium case and 316 stainless steel adjustment cover.

**Microswitch:** 1 x SPCO/SPDT or 2 x SPCO/SPDT gold flashed silver contacts. Single switch is available with adjustable deadband option. Dual switches are either mechanically linked to provide DPDT switching action (reset of switches could be up to 3% apart) or independently adjustable. Microswitches are environmentally sealed as standard, hermetically sealed can be supplied as an option. Dual microswitches may increase deadband by a factor of two.

**Microswitch rating:** 5 Amps @ 250 VAC resistive, 2 Amps @ 250VAC inductive  
5 Amps @ 30VDC resistive, 2 Amps @ 30 VDC inductive

**Electrical Connections:** Terminals suitable for cable 0.5 - 2.5 mm<sup>2</sup>. (Max 1.5 mm<sup>2</sup> for dual microswitch version)

**Electrical Conduit Entry:** One or two M20 x 1.5 ISO. ½" NPT or M25 via adaptors

**Environmental Protection:** IP66 & IP67 in accordance with BS EN 60529 : 1992 & IEC 60529 : 2001.

**Vibration and shock parameters:** Switches were subjected Lloyds Register Test Specification 1, section 13 BS EN 60068-2-6 : 1996 (Test Fc vibration) and BS EN 60068-2-27 : 1995 (Test Ea shock).

**Temperature Limitations:** Pressure, Vacuum and Differential Pressure.

**Process:** Diaphragm actuated (unless otherwise stated) -30 to +100°C (Nitrile) or -20 to +150 Deg.C (Viton).  
Piston actuated -30 to 100°C (Nitrile), -20 to +150°C (Viton), -50 to +150°C (PTFE) or -35 to +100°C (EPDM).

**Ambient:** -40 to +85°C. -50 to +125°C option - refer to sales office)

**Storage:** -50 to +85 Deg.C (For temperature, level and flow switches please refer to specific pages).

**ATEX/IECEx certified Exd Flameproof - Gas** (with or without resistors) CE Ex II 2 G Exd IIC T6...T5 Gb. T6 Tamb -50°C to +75°C, T5 Tamb -50°C to +90°C.

Special conditions for safe use. 1) Under rated conditions, the cable temperature can reach 9K above ambient temperature, ensure selection of correctly rated cable for the application. 2) Flameproof joints not intended for repair.

## ATEX/IECEx certified Exia Intrinsically Safe - Gas & dust

CE Ex II 1 G Exia IIC T6 Ga Ta -50 to +78°C, T5 Ta +93°C, T4 Ta +128°C or  
CE Ex II 1 G Exia IIC T5 Ga Ta -50 to +72°C, T4 Ta +122°C (with resistors).  
CE Ex II 1 D Exia IIC T135°C Da Ta -50 to +70°C

Special conditions for safe use. 1) For Ga installations - The equipment may be constructed using aluminium for the housing and internal parts and may only be used when the ignition hazardous assessment shows there is no risk of ignition from incendive impact or abrasion sparks.

**Accuracy: +/-1% at 20°C.**

Continuous development may result in changes to specification without prior notice

## ABOUT PYROPRESS

Our products are designed to work in demanding and hazardous environments which require fast and cost effective solutions in instrumentation and control.

Pyropress control sensors provide safe and reliable electrical switching of alarm or control circuits in response to changes in temperature, pressure, differential pressure, vacuum, flow and level conditions.

## QUALITY

To support the design of state of the art products the company has invested heavily in the latest CNC technology.

We are able to produce our own components to a high degree of accuracy assuring a reliable and consistent quality product.

T: +44 (0)1752 333933 | [sales@pyropress.com](mailto:sales@pyropress.com)  
[www.pyropress.com](http://www.pyropress.com)

PPSSC1063 | issue 2