

PERSEUS ULTRA LOW PRESSURE

PF60 ATEX & IECEx Exd, Exia & INDUSTRIAL ULTRA LOW PRESSURE SWITCH

This range of switches features a robust high quality housing with 1 or 2 sealed SPDT microswitches and has been designed for use in environments where explosive gases can be present (e.g. gas fields, oil rigs & chemical plants etc). Microswitches can be set for single, dual simultaneous, or dual independently adjustable operation. Environmentally sealed or hermetically sealed microswitch options are available.

One of the benefits of the Perseus range is the separation of the flameproof and adjustment chambers allowing adjustment of the set point with power on and the switch in operation. The housing is available with one or two electrical entries.



ULTRA LOW PRESSURE

FEATURES

- ✓ 316 Stainless steel or black anodised aluminium switchcase to IP66 & IP67 standards.
- ✓ Wetted parts NACE MR-01-75 compliant.
- ✓ SIL 2 – IEC61508 proven reliability.
- ✓ Single or dual microswitch option.
- ✓ Setting from 0.4 mbar to 55 mbar.
- ✓ ATEX/IECEX Flameproof version
II 2 G Ex db IIC T6...T5 Gb
(Tamb -50°C to +75°C...+90°C)
(with or without resistors)
- ✓ ATEX/IECEX Intrinsically safe version
II 1 G Ex ia IIC T6...T2 Ga
(Tamb - 50°C to +78°C...+93°C)
(without resistors)
- ✓ ATEX/IECEX/AEx Intrinsically safe
CE II1G Exia IIC
T5 - 50 to +72°C & T4 - 50 to +122°C
(with resistors)
- ✓ ATEX/IECEX Intrinsically safe version
II 1 D Ex ia IIIC T135°C Da
(Tamb -50°C to +70°C)
(with or without resistors)

ADJUSTMENT RANGE (BAR D)	MINIMUM WORKING PRESSURE (BAR)	MAXIMUM WORKING PRESSURE (BAR)	DEADBAND FIXED (Mbar G)	SPRING CODE	DIAPHRAGM CODE
15 – 55 mBar	-0.35	0.35	1.5 – 7.5	B	08SB
4 – 16 mBar	-0.35	0.35	0.75 – 2.0	G	08SB
1 – 5 mBar	-0.35	0.35	0.25 – 1.0	R	08SB
0.4 – 1.8 mBar	-0.35	0.35	0.2 – 0.3	T	08SB

Dual microswitches will increase the stated deadband.

Temperature Limitations

Viton : -20 to +150°C

Nitrile : -30 to +100°C

Wetted Parts - Metallic

316 stainless steel

Process Connections : Diaphragm code 08SB as table below.

PART NUMBER BREAKDOWN	MICROSWITCH OPTIONS 1 = 1 X SPDT 2 = 2 X SPDT LINKED 3* = 1 x SPDT WITH ADJUSTABLE DEADBAND 4* = 2 x SPDT INDEPENDENT ADJUSTABLE	ELECTRICAL CONNECTION _ = M20 LEAVE BLANK C = 1/2" NPT ADAPTOR F = M25 ADAPTOR		
	TYPE PF6 = ULTRA LOW PRESSURE E.G. PR6 = RESISTOR OPTION	5 = 1 X HERMETIC SEALED 6 = 2 X HERMETIC SEALED * ONLY AVAILABLE WITH "B" ELECTRICAL CONNECTION ENTRY	SPRING CODE PLEASE REFER TO RANGE TABLE	DIAPHRAGM CODE PLEASE REFER TO RANGE TABLE

P F 6 1 A B / 2 R 0 8 S B 1 / W B _

SWITCHCASE MATERIAL A = BLACK ANODISED ALUMINIUM S = 316 STAINLESS STEEL	ELECTRICAL CONNECTION ENTRY B = RIGHT HAND SIDE L* = DUAL ENTRY TOP PLUGGED T* = DUAL ENTRY SIDE PLUGGED R* = DUAL ENTRY *STAINLESS STEEL ONLY
CERTIFICATION O = ATEX/IECEX Exia INTRINSICALLY SAFE B = ATEX/IECEX Exd FLAMEPROOF A = INDUSTRIAL / MARINE	
DIAPHRAGM MATERIAL 1 = NITRILE 2 = VITON	
PROCESS CONNECTION - DIAPHRAGM CODES 08SB 4 = 1/4" O/D TUBE - POSITIONAL ELBOW - PR 9 = SPECIAL B = 6MM O/D TUBE POSITIONAL ELBOW - PR/VAC D = 8MM O/D TUBE POSITIONAL ELBOW PR/VAC F = 10MM O/D TUBE POSITIONAL ELBOW - PR/VAC H = 12MM O/D TUBE POSITIONAL ELBOW - PR/VAC	K = 1/4" BSP.P FEMALE STRAIGHT - PR/VAC M = 1/4" BSP.T FEMALE STRAIGHT - PR/VAC P = 1/4" BSP.P MALE STRAIGHT - PR/VAC R = 1/4" NPT FEMALE STRAIGHT - PR/VAC T = 1/4" NPT MALE STRAIGHT - PR/VAC V = 1/2" NPT FEMALE STRAIGHT - PR/VAC

DIMENSIONS IN MILLIMETERS UNLESS OTHERWISE STATED

PROCESS CONNECTIONS

1/2" O.D. TUBE POSITIONABLE ELBOW	NOT SHOWN DETAILS ARE AVAILABLE UPON REQUEST
5mm O.D. TUBE POSITIONABLE ELBOW	
10mm O.D. TUBE POSITIONABLE ELBOW	
12mm O.D. TUBE POSITIONABLE ELBOW	
1/2" O.D. TUBE POSITIONABLE BRANCH TEE	
1/2" O.D. TUBE POSITIONABLE RUN TEE	
1/2" BSP/F FEMALE STRAIGHT	
1/2" BSP/T FEMALE STRAIGHT	
1/2" NPT FEMALE STRAIGHT	
1/2" NPT MALE STRAIGHT	
1/2" NPT FEMALE STRAIGHT	
1/2" NPT MALE STRAIGHT	

*T CODE - BRACKET WITH #52mm (2") PIPE CLAMPS

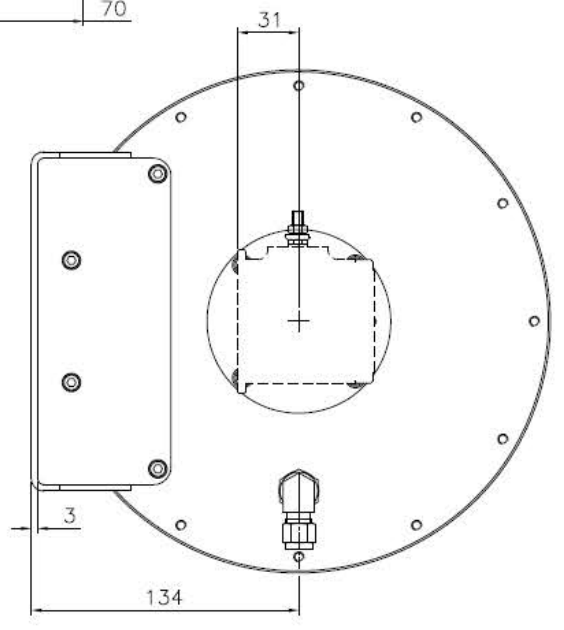
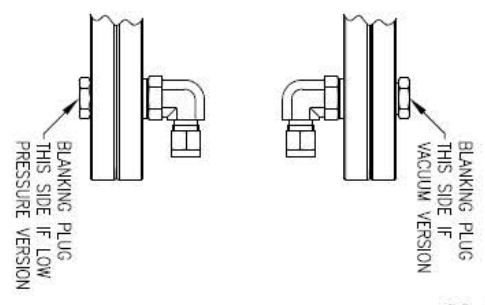
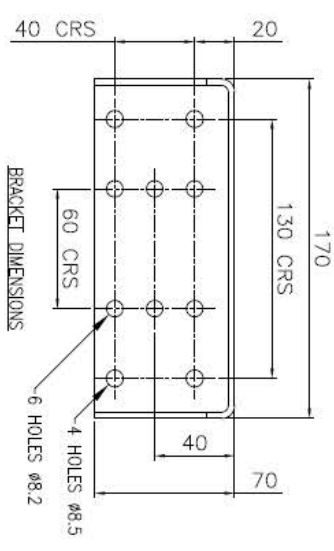
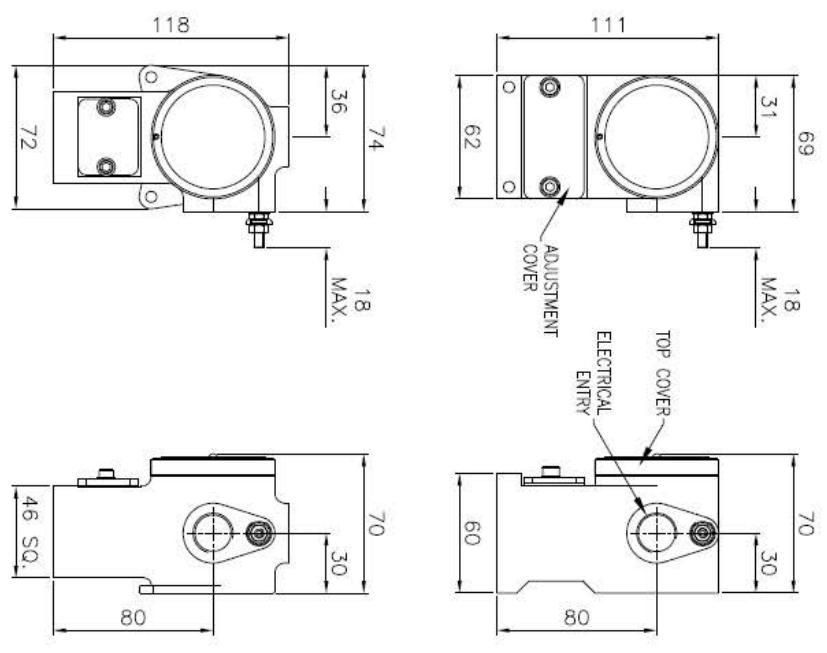
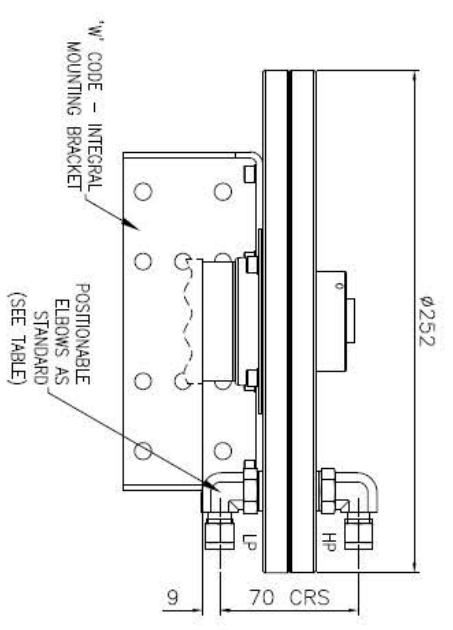
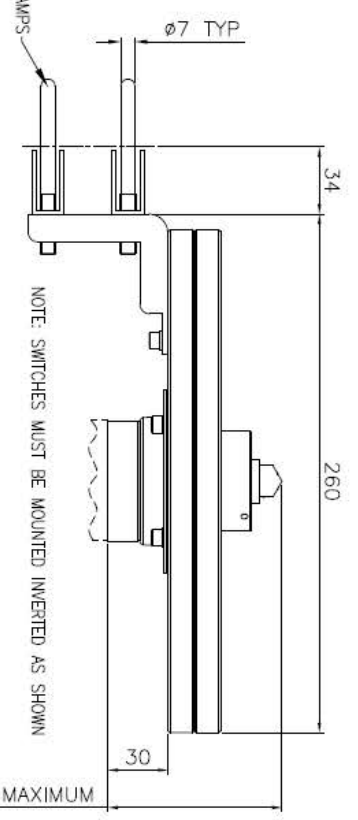

PERSEUS ATEX & IECEx Exd, Exia &

INDUSTRIAL SWITCHES

INTRODUCTION

The Perseus **pressure, vacuum, differential pressure, temperature, and level** switches are designed for use in environments where explosive gases and dust can be present (e.g. Gas fields, Oil rigs and Chemical plants etc.) and have been ATEX and IECEx certified as detailed overleaf (SIL2 - IEC61508 proven reliability).

These switches are manufactured from a high quality casting which offers robust construction and protection to IP67 for use within heavily polluted industrial environments. A special feature of the instruments is the separation of the flameproof and adjustment compartments allowing for safe on-site adjustment of the set point with power on and the switch in operation.

Perseus Exd switches must be installed in accordance with BS EN 60079-14

CALIBRATION

The design features a simple form of adjustment against a calibrated scale. This enables a user to order switches set at a predetermined point or stock a mid range setting and adjust switches to suit the particular application. The set point can be safely adjusted with the switch electrically live. Adjustment is made by removing the access cover and rotating the set point adjuster using a suitable tommy bar stowed to the right of the scale plate. The setting is read from the centre of the set point adjuster against the calibrated scale. Rotation to the left will increase the set point and to the right decrease it.

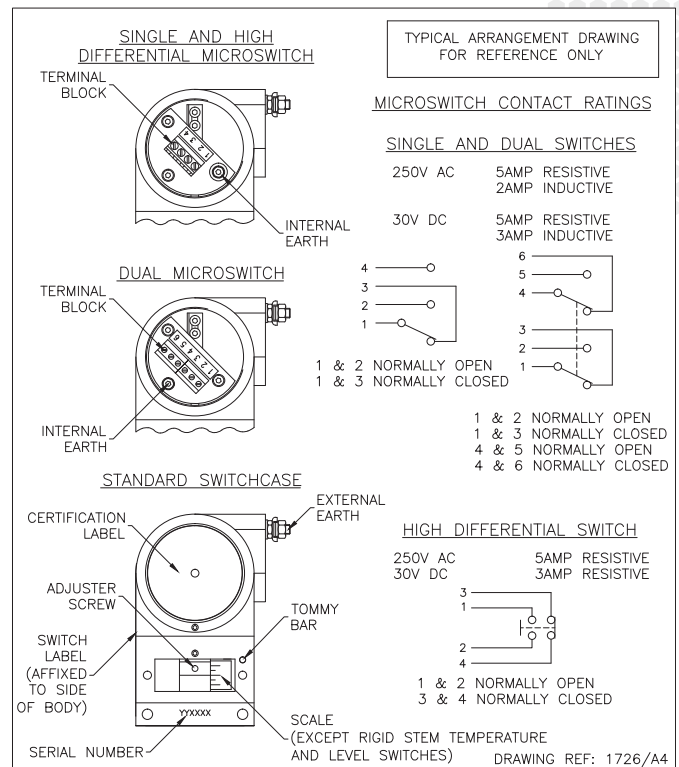

Perseus Stainless steel switchcase with dual electrical connection option

TECHNICAL SPECIFICATION

Switchcase & covers: 316 Stainless steel or black anodised aluminium case and 316 stainless steel adjustment cover.

Microswitch: 1 x SPCO/SPDT or 2 x SPCO/SPDT gold flashed silver contacts. Single switch is available with adjustable deadband option. Dual switches are either mechanically linked to provide DPDT switching action (reset of switches could be up to 3% apart) or independently adjustable. Microswitches are environmentally sealed as standard, hermetically sealed can be supplied as an option. Dual microswitches may increase deadband by a factor of two.

Microswitch rating: 5 Amps @ 250 VAC resistive, 2 Amps @ 250VAC inductive
5 Amps @ 30VDC resistive, 2 Amps @ 30 VDC inductive

Electrical Connections: Terminals suitable for cable 0.5 - 2.5 mm². (Max 1.5 mm² for dual microswitch version)

Electrical Conduit Entry: One or two M20 x 1.5 ISO. ½" NPT or M25 via adaptors

Environmental Protection: IP66 & IP67 in accordance with BS EN 60529 : 1992 & IEC 60529 : 2001.

Vibration and shock parameters: Switches were subjected Lloyds Register Test Specification 1, section 13 BS EN 60068-2-6 : 1996 (Test Fc vibration) and BS EN 60068-2-27 : 1995 (Test Ea shock).

Temperature Limitations: Pressure, Vacuum and Differential Pressure.

Process: Diaphragm actuated (unless otherwise stated) -30 to +100°C (Nitrile) or -20 to +150 Deg.C (Viton).
Piston actuated -30 to 100°C (Nitrile), -20 to +150°C (Viton), -50 to +150°C (PTFE) or -35 to +100°C (EPDM).

Ambient: -40 to +85°C. -50 to +125°C option - refer to sales office)

Storage: -50 to +85 Deg.C (For temperature, level and flow switches please refer to specific pages).

ATEX/IECEx certified Exd Flameproof - Gas (with or without resistors) CE Ex II 2 G Exd IIC T6...T5 Gb.
T6 Tamb -50°C to +75°C, T5 Tamb -50°C to +90°C.

Special conditions for safe use. 1) Under rated conditions, the cable temperature can reach 9K above ambient temperature, ensure selection of correctly rated cable for the application. 2) Flameproof joints not intended for repair.

ATEX/IECEx certified Exia Intrinsically Safe - Gas & dust

CE Ex II 1 G Exia IIC T6 Ga Ta -50 to +78°C, T5 Ta +93°C, T4 Ta +128°C or

CE Ex II 1 G Exia IIC T5 Ga Ta -50 to +72°C, T4 Ta +122°C (with resistors).

CE Ex II 1 D Exia IIIC T135°C Da Ta -50 to +70°C

Special conditions for safe use. 1) For Ga installations - The equipment may be constructed using aluminium for the housing and internal parts and may only be used when the ignition hazardous assessment shows there is no risk of ignition from incendive impact or abrasion sparks.

Accuracy: +/-1% at 20°C.

Continuous development may result in changes to specification without prior notice

ABOUT PYROPRESS

Our products are designed to work in demanding and hazardous environments which require fast and cost effective solutions in instrumentation and control.

Pyropress control sensors provide safe and reliable electrical switching of alarm or control circuits in response to changes in temperature, pressure, differential pressure, vacuum, flow and level conditions.

QUALITY

To support the design of state of the art products the company has invested heavily in the latest CNC technology.

We are able to produce our own components to a high degree of accuracy assuring a reliable and consistent quality product.

T: +44 (0)1752 333933 | sales@pyropress.com
www.pyropress.com

PPSSC1067 | issue 2